**Rubber — Assessment of carbon black
and carbon black/silica dispersion —
Rapid comparative methods**

*Caoutchouc — Évaluation de la dispersion du noir de carbone et du noir
de carbone/silice — Méthodes comparatives rapides*

STANDARDSISO.COM : Click to view the full PDF of ISO 11345:2006



PDF disclaimer

This PDF file may contain embedded typefaces. In accordance with Adobe's licensing policy, this file may be printed or viewed but shall not be edited unless the typefaces which are embedded are licensed to and installed on the computer performing the editing. In downloading this file, parties accept therein the responsibility of not infringing Adobe's licensing policy. The ISO Central Secretariat accepts no liability in this area.

Adobe is a trademark of Adobe Systems Incorporated.

Details of the software products used to create this PDF file can be found in the General Info relative to the file; the PDF-creation parameters were optimized for printing. Every care has been taken to ensure that the file is suitable for use by ISO member bodies. In the unlikely event that a problem relating to it is found, please inform the Central Secretariat at the address given below.

STANDARDSISO.COM : Click to view the full PDF of ISO 11345:2006

© ISO 2006

All rights reserved. Unless otherwise specified, no part of this publication may be reproduced or utilized in any form or by any means, electronic or mechanical, including photocopying and microfilm, without permission in writing from either ISO at the address below or ISO's member body in the country of the requester.

ISO copyright office
Case postale 56 • CH-1211 Geneva 20
Tel. + 41 22 749 01 11
Fax + 41 22 749 09 47
E-mail copyright@iso.org
Web www.iso.org

Published in Switzerland

Contents

Page

| | |
|---|----|
| Foreword..... | iv |
| Introduction | v |
| 1 Scope | 1 |
| 2 Normative references | 1 |
| 3 Terms and definitions..... | 1 |
| 4 Principle..... | 1 |
| 5 Number of tests..... | 2 |
| 6 Method A — Visual microscopic or photographic microscopic inspection with × 30 magnification..... | 2 |
| 7 Method B — Split-field microscopic inspection with × 30 magnification | 3 |
| 8 Method C — Visual microscopic or photographic microscopic inspection with × 100 magnification..... | 6 |
| 9 Method D — Split-field microscopic inspection with × 100 magnification | 7 |
| 10 Method E — Large-agglomerate count with × 100 magnification | 8 |
| 11 Test report | 10 |
| Annex A (normative) Visual dispersion rating vs dispersion classification at × 30 magnification (methods A and B) | 11 |
| Annex B (normative) Visual dispersion rating vs dispersion classification at × 100 magnification — Carbon black (CB) | 12 |
| Annex C (normative) Visual dispersion rating vs dispersion classification at × 100 magnification — Reinforcing carbon black (RCB) | 15 |
| Annex D (informative) Visual dispersion rating vs dispersion classification at × 100 magnification — Reinforcing carbon black with silica (RCB/Silica) | 18 |
| Annex E (normative) Visual dispersion rating vs dispersion classification at × 100 magnification — Semi-reinforcing carbon black (SRCB) | 21 |
| Annex F (informative) Dispersion in rubber | 24 |
| Bibliography..... | 26 |

Foreword

ISO (the International Organization for Standardization) is a worldwide federation of national standards bodies (ISO member bodies). The work of preparing International Standards is normally carried out through ISO technical committees. Each member body interested in a subject for which a technical committee has been established has the right to be represented on that committee. International organizations, governmental and non-governmental, in liaison with ISO, also take part in the work. ISO collaborates closely with the International Electrotechnical Commission (IEC) on all matters of electrotechnical standardization.

International Standards are drafted in accordance with the rules given in the ISO/IEC Directives, Part 2.

The main task of technical committees is to prepare International Standards. Draft International Standards adopted by the technical committees are circulated to the member bodies for voting. Publication as an International Standard requires approval by at least 75 % of the member bodies casting a vote.

Attention is drawn to the possibility that some of the elements of this document may be the subject of patent rights. ISO shall not be held responsible for identifying any or all such patent rights.

ISO 11345 was prepared by Technical Committee ISO/TC 45, *Rubber and rubber products*, Subcommittee SC 2, *Testing and analysis*.

This second edition cancels and replaces the first edition (ISO 11345:1997), which has been technically revised.

STANDARDSISO.COM : Click to view the full PDF of ISO 11345:2006

Introduction

The degree of filler dispersion in a rubber compound is important because certain physical properties, e.g. tensile strength, hysteresis and abrasion resistance, are influenced by dispersion.

The methods described in this International Standard make use of the well known fact that, in a compound in which the ingredients are well dispersed, light is reflected from a freshly cut surface, revealing a smooth, unblemished texture. The presence of improperly dispersed ingredients is shown by irregularities which usually take the form of circular, convex "bumps" or concave pockmarks on the surface, and their presence indicates a less-than-perfect dispersion of the compounding ingredients. The size and frequency of these irregularities may be used to judge the degree to which the compound falls short of an optimum dispersion. A set of four standards each comprising ten photographs based on size and frequency of these irregularities has been established to which numerical ratings have been assigned. This scheme provides a means of evaluating dispersion in a rubber compound and assigns numerical designations to the degrees of dispersion.

This International Standard describes test procedures for assessing the degree of macrodispersion of carbon black and silica in rubber. The methods are primarily intended to be used as rapid factory controls during mixing and subsequent processing stages to assure adequate carbon black dispersion. Five alternative methods are described.

The addition of a higher magnification and photographic reference standards for silica was in response to a request from tyre manufacturers and filler producers. Method E was specially requested by manufacturers of extruded profiles for the automotive industry.

Equipment with electronically stored standards may be supplied by:

TechPro, Inc

121 East Ascot Lane,
Cuyahoga Falls, OH 44223,
USA

Telephone +1 330 923 3546
Telefax +1 330 923 6335

www.techpro-usa.com

[STANDARDSISO.COM](https://standardsiso.com) : Click to view the full PDF of ISO 11345:2006

Rubber — Assessment of carbon black and carbon black/silica dispersion — Rapid comparative methods

WARNING — Persons using this International Standard should be familiar with normal laboratory practice. This standard does not purport to address all of the safety problems, if any, associated with its use. It is the responsibility of the user to establish appropriate safety and health practices and to ensure compliance with any national regulatory conditions.

1 Scope

This International Standard specifies qualitative visual methods for the rapid and comparative assessment of the degree of macrodispersion of carbon black and carbon black/silica in rubber. Ratings are made relative to a set of standard reference photographs, and the results are expressed on a numerical scale from 1 to 10.

In addition, a method is given for rating the presence of large agglomerates on a numerical scale (ratings 1 to 10).

2 Normative references

The following referenced documents are indispensable for the application of this document. For dated references, only the edition cited applies. For undated references, the latest edition of the referenced document (including any amendments) applies.

ISO 1382, *Rubber — Vocabulary*

3 Terms and definitions

For the purposes of this document, the terms and definitions given in ISO 1382 apply.

4 Principle

The carbon black or carbon black/silica filled rubber compound is cut to expose a fresh surface for examination under magnification.

Five methods are described:

- **Method A:** Visual microscopic or photographic microscopic inspection with $\times 30$ magnification (for carbon black).
- **Method B:** Split-field microscopic inspection with $\times 30$ magnification (for carbon black).
- **Method C:** Visual microscopic or photographic microscopic inspection with $\times 100$ magnification (for carbon black or carbon black/silica).
- **Method D:** Split-field microscopic inspection with $\times 100$ magnification (for carbon black or carbon black/silica).
- **Method E:** Large-agglomerate count with $\times 100$ magnification (for carbon black).

In methods A to D, the dispersion level is compared with a series of ten hard-copy or electronically stored standard references under oblique illumination at 30° (to accentuate detail) and with an effective magnification of × 30 for methods A and B (see Annex A) and × 100 for methods C and D (see Annexes B to E), and then rated numerically from 10 (excellent) to 1 (very poor).

A rating of 10 indicates a state of dispersion resulting in near optimum physical properties while a rating of 1 would indicate structural flaws causing considerably inferior physical properties. Normally, the visual dispersion ratings indicate the following levels of compound quality.

| Visual dispersion rating | Dispersion classification |
|--------------------------|---------------------------|
| 9 to 10 | Excellent |
| 8 | Good |
| 7 | Acceptable |
| 5 to 6 | Doubtful |
| 3 to 4 | Poor |
| 1 to 2 | Very poor |

In method E, the presence of agglomerates is analysed using an image-processing system under oblique illumination at 30° and with an effective magnification of × 100, and then rated numerically from 10 (excellent) to 1 (very poor). The rating 10 is based on the absence of clusters with a diameter of 23 µm or larger, indicating that the agglomerates are much smaller than this. The rating 1 corresponds to the maximum number of large agglomerates which can be achieved in practice.

5 Number of tests

A minimum of five tests on different parts of each test piece shall be carried out.

6 Method A — Visual microscopic or photographic microscopic inspection with × 30 magnification

6.1 General

Method A is a test method which determines the degree of dispersion of carbon black in rubber compounds by means of visual microscopic or photographic microscopic inspection, which is used to rate the test piece against a set of transparencies or electronically stored standard references.

6.2 Apparatus

6.2.1 Razor blade, with a single edge, attached to a sample cutter.

6.2.2 Sample cutter, comprising a razor blade holder and a lever mechanism which provides a vertical cutting action.

6.2.3 Binocular microscope (× 30), or 6.2.4.

6.2.4 Binocular microscope (× 30), equipped with a standard self-developing or digital camera with at least 2 megapixel resolution.

6.2.5 Illuminator, microscope type, with high luminous intensity.

6.3 Test piece

6.3.1 Vulcanized compound

Using the sample cutter, cut out a test piece with a cross-section of approximately 8 mm thickness and 10 mm width. Do not touch the surface to be used for rating. The razor blade shall be replaced before the edge wears to the extent that the cut becomes lined.

6.3.2 Unvulcanized compound

The compound shall first be compressed to remove most of the air holes since, even in small amounts, they can have the appearance of poorly dispersed carbon black and can therefore affect the rating. To accomplish this, press the rubber into a slab between thin sheets of plastic in a mould at a pressure of about 1 kPa for 5 min at 105 °C. Take care to avoid excessive flow during this step. The surface to be examined shall, as far as possible, be free from distortion and blemishes. To achieve this, the cutting edge of the tool shall be free from defects and the distortion of the sample shall be minimized by applying the cutting pressure evenly and slowly with the sharp razor blade heated to approximately 100 °C. However, even with all these precautions, the evaluation of a cured test piece of the same compound may give a different result.

6.4 Procedure

Examine the prepared test piece under the binocular microscope with oblique illumination (at an angle of incidence of 30°) to accentuate surface detail. The illuminator should preferentially be placed parallel to the direction of cutting since any cutting lines will show less.

Compare the size and frequency of any carbon black agglomerates in the test piece (showing up as surface bumps or depressions) with those in the reference photographs (see Annex A).

NOTE If a microscope with a self-developing or digital camera is used, the dispersion can be assessed by side-by-side comparison with the reference photographs using the photograph obtained. This provides a permanent record of the test piece appearance in a matter of minutes.

Assign to each compound being assessed the most closely matching numerical rating, using whole numbers. For closer matching, use fractional ratings: 5 1/2 would indicate a rating between 5 and 6.

A rating of 10 indicates a state of dispersion representing near-optimum physical properties while a rating of 1 indicates the presence of structural flaws, resulting in inferior physical properties.

7 Method B — Split-field microscopic inspection with × 30 magnification

7.1 General

Method B determines the degree of dispersion of carbon black in rubber compounds by means of a split-field viewing technique which is used to rate the test piece against a set of transparencies or electronically stored standard reference images. The assessment of the degree of carbon black dispersion using the split-field optical-microscopic technique is accomplished by co-projection of the reference images and the test piece image on a TV monitor using a black-and-white video camera or a CCD camera.

The reference images are identical to the photographic references used in method A.

7.2 Apparatus

7.2.1 Razor blade, with a single edge, attached to a sample cutter.

7.2.2 Sample cutter, comprising a razor blade holder and a lever mechanism which provides a vertical cutting action.

7.2.3 Equipment for split-field representation. The instrument is based on the so-called split-field optical-microscope technique in which each of the 10 references can be projected side by side with the reflected image of the test piece surface. The references are mounted on a rotary disc (in the case of transparencies) or are electronically stored (in the case of digital images) and can be viewed successively until the reference which best matches the appearance of the test piece surface is found.

A video camera or CCD camera is used together with a monitor to provide a composite side-by-side picture of the test piece and a reference (see Figures 1 and 2).

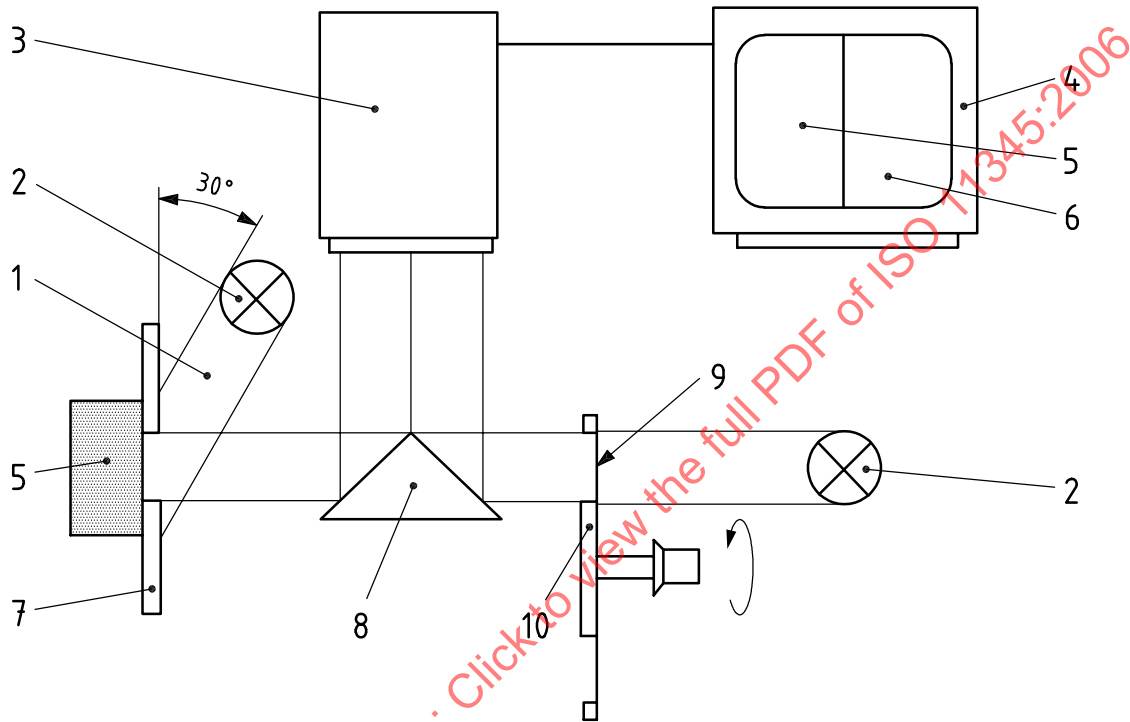

Key

- | | |
|----------------|--------------------------|
| 1 light beam | 6 reference |
| 2 lamp | 7 test piece holder |
| 3 video camera | 8 prism |
| 4 TV monitor | 9 reference transparency |
| 5 test piece | 10 transparency carrier |

Figure 1 — Apparatus for methods B and D with a video camera

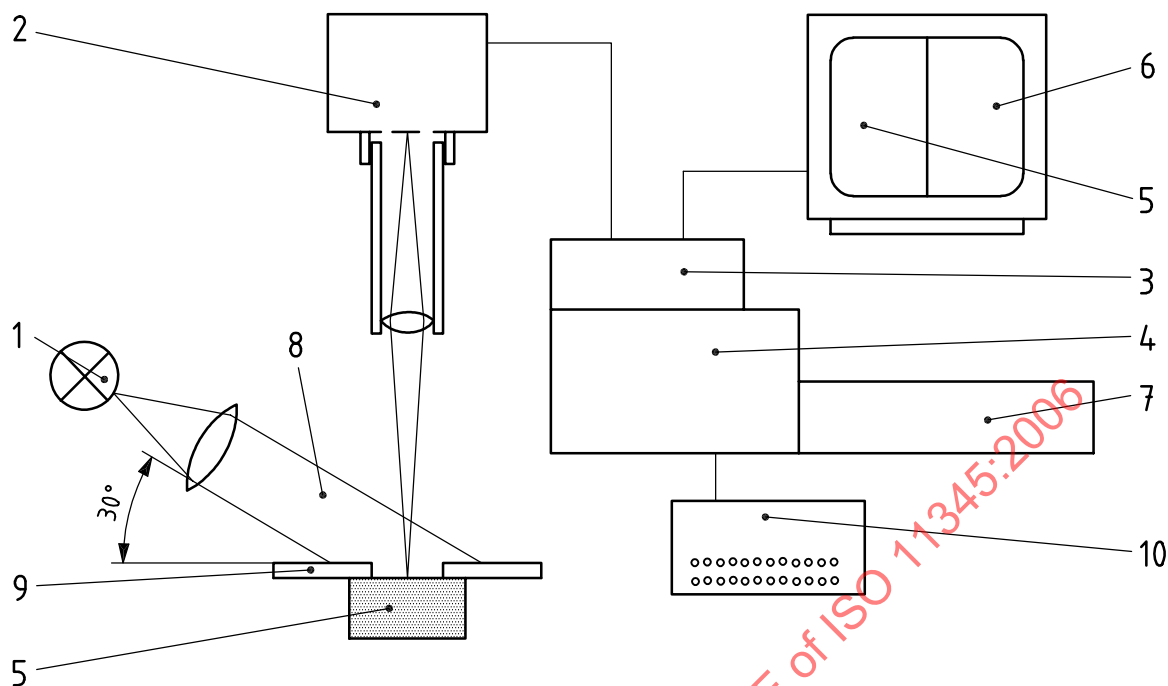

Key

- | | |
|-----------------|-------------------------------------|
| 1 lamp | 6 reference |
| 2 CCD camera | 7 digital memory (reference images) |
| 3 electronics | 8 light beam |
| 4 microcomputer | 9 test piece holder |
| 5 test piece | 10 keyboard |

Figure 2 — Apparatus for methods B and D with a CCD camera

7.3 Test piece

Prepare the test piece for method B in the same manner as described in 6.3.

7.4 Procedure

Switch on the instrument and allow it to warm up for the specified time.

Place the test piece with the freshly cut surface resting against the test piece holder. The test piece shall be placed in the same way as it was in the cutter, with the cutting direction vertical.

Examine the prepared test piece in the instrument with oblique illumination (at an angle of incidence of 30°). Compare the size and frequency of any carbon black agglomerates in the test piece (showing up as bumps or depressions) to the size and frequency of the agglomerates in the reference images by direct side-by-side comparison. Choose, from the reference images, the one that most closely matches the image of the test piece by successively projecting the reference images beside the image of the test piece under examination.

Assign the most closely matching numerical rating to each compound being assessed in whole numbers. For closer matching, use fractional ratings; 5 1/2 would indicate a rating between 5 and 6.

A rating of 10 indicates a state of dispersion representing near-optimum physical properties while a rating of 1 indicates the presence of structural flaws, resulting in inferior physical properties.

8 Method C — Visual microscopic or photographic microscopic inspection with × 100 magnification

8.1 General

Method C determines the degree of dispersion of carbon black or carbon black/silica in rubber compounds by means of visual microscopic or photographic microscopic inspection, which is used to rate the test piece against a set of transparencies or electronically stored standard references.

8.2 Apparatus

8.2.1 Razor blade, with a single edge, attached to a sample cutter.

8.2.2 Sample cutter, comprising a razor blade holder and a lever mechanism which provides a vertical cutting action.

8.2.3 Binocular microscope (× 100), or 8.2.4.

8.2.4 Binocular microscope (× 100), equipped with a standard self-developing or digital camera with at least 2 megapixel resolution.

8.2.5 Illuminator, microscope type, with high luminous intensity.

8.3 Test piece

Prepare the test piece for method C in the same manner as described in 6.3.

8.4 Procedure

Examine the prepared test piece under the binocular microscope with oblique illumination (at an angle of incidence of 30°) to accentuate surface detail. The illuminator should preferably be placed so that the light beam is parallel to the direction of cutting, so that any cutting lines will show less.

Compare the size and frequency of any carbon black or carbon black/silica agglomerates in the test piece (showing up as surface bumps or depressions) to the size and frequency of the agglomerates in the reference images. Use the set of references that is closest to the main type of filler used in the compound. (The relationships between the sets of references are illustrated in Figure 3.)

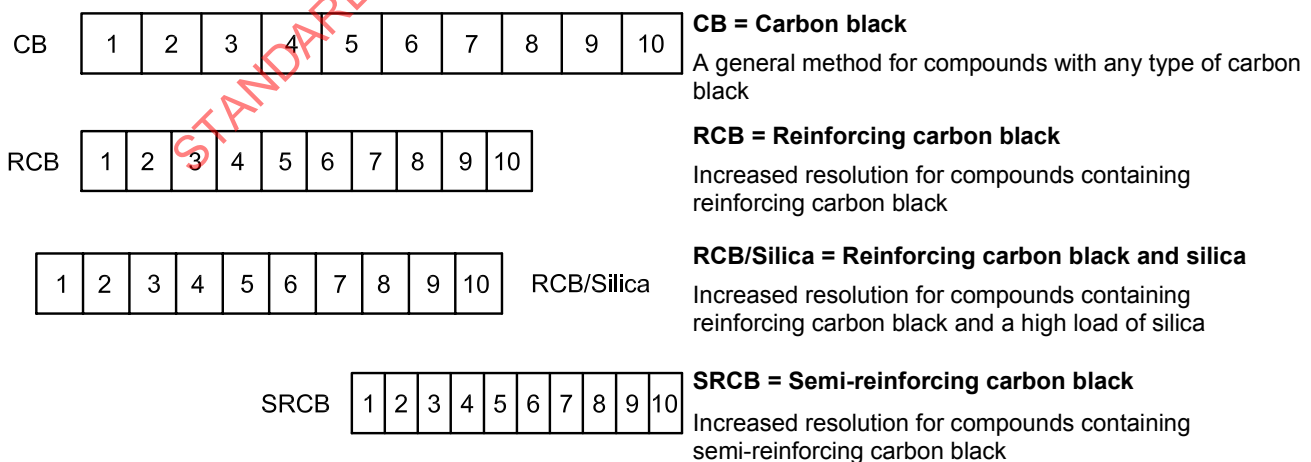

Figure 3 — The principle of the photographic references used in methods C and D

The photographic references are shown full size in Annexes B to E.

NOTE If a microscope with a self-developing or digital camera is used, the dispersion can be assessed by side-by-side comparison with the reference photographs using the photograph obtained. This provides a permanent record of the test piece appearance in a matter of minutes.

Assign to each compound being assessed the most closely matching numerical rating, using whole numbers. For closer matching, use fractional ratings: 5 1/2 would indicate a rating between 5 and 6.

A rating of 10 indicates a state of dispersion representing near-optimum physical properties while a rating of 1 indicates the presence of structural flaws, resulting in inferior physical properties.

9 Method D — Split-field microscopic inspection with $\times 100$ magnification

9.1 General

Method D determines the degree of dispersion of carbon black or carbon black/silica in rubber compounds by means of a split-field viewing technique which is used to rate the test piece against a set of transparencies or electronically stored standard reference images. The assessment of the degree of carbon black or carbon black/silica dispersion using the split-field optical-microscopic technique is accomplished by co-projection of the standard reference images and the test piece image on a TV monitor using a black-and-white video camera or a CCD camera.

The references used are the same as those utilized for method C (see Figure 3).

9.2 Apparatus

9.2.1 Razor blade, with a single edge, attached to a sample cutter.

9.2.2 Sample cutter, comprising a razor blade holder and a lever mechanism which provides a vertical cutting action.

9.2.3 Equipment for split-field representation. The instrument is based on the so-called split-field optical-microscope technique in which each of the 10 references can be projected side by side with the reflected image of the test piece surface. The references can be mounted on a rotating disc (in the case of transparencies) or can be electronically stored (in the case of digital images), and can be viewed successively until the reference which best matches the appearance of the test piece surface is found.

A video or CCD camera is used together with a monitor to provide a side-by-side composite picture of test piece and reference (see Figures 1 and 2).

9.3 Test piece

Prepare the test piece for method D in the same manner as described in 6.3.

9.4 Procedure

Switch on the instrument and allow it to warm up for the specified time.

Place the test piece with the freshly cut surface resting against the test piece holder. The test piece shall be placed in the same way as it was in the cutter, with the cutting direction vertical.

Examine the prepared test piece in the instrument with oblique illumination (at an angle of incidence of 30°). Compare the size and frequency of any carbon black or carbon black/silica agglomerates in the test piece (showing up as bumps or depressions) to the size and frequency of the agglomerates in the reference images by direct side-by-side comparison. Use the set of references that is closest to the main type of filler used in the compound. (The relationships between the sets of references are illustrated in Figure 3 and the references are

shown full size in Annexes B to E.) Choose, from the reference images, the one that most closely matches the image of the test piece by successively projecting the reference images beside the image of the test piece under examination.

Assign the most closely matching numerical rating to each compound being assessed in whole numbers. For closer matching, use fractional ratings; 5 1/2 would indicate a rating between 5 and 6.

A rating of 10 indicates a state of dispersion representing near-optimum physical properties while a rating of 1 indicates the presence of structural flaws, resulting in inferior physical properties.

10 Method E — Large-agglomerate count with × 100 magnification

10.1 General

Method E determines the degree of dispersion of carbon black in rubber compounds by means of a split-field CCD camera arrangement. This is used to rate the test piece in terms of the percentage of the test area that is covered by irregularities (so-called nodules) caused by underlying agglomerates. The agglomerate count is accomplished using an image-processing system in which a CCD camera and a frame grabber are used to analyse the nodules in a cut rubber surface.

The rating, or *y*-value, is given on a numerical scale from 1 to 10 (see Table 1), where 10 represents the total absence of agglomerates with a diameter of 23 µm or larger, and 1 represents a large number of such agglomerates (corresponding to 19 % of the test area), and is calculated from the equation

$$y = 10 - 9 \times \frac{N_w}{0,19 \times N_{tot}}$$

where

N_w is the number of white pixels in the image of the test area due to nodules with an average diameter of 23 µm or larger caused by underlying agglomerates;

N_{tot} is the total number of pixels in the image of the test area.

NOTE For more information, see Annex F.

Table 1 — White area and *y*-value

| White area % | <i>y</i> -value |
|-----------------|-----------------|
| 19 | 1 |
| | 2 |
| | 3 |
| | 4 |
| | 5 |
| | 6 |
| | 7 |
| | 8 |
| | 9 |
| 0 | 10 |

The principle is illustrated in Figure 4. All nodules with a diameter lower than $23\ \mu\text{m}$ are ignored, as these are usually regarded as having little influence on the properties of the final product. Then, the white areas that all the remaining nodules give are added together. This total white area is then translated into a value between 1 and 10 using the equation above. (The curve representing a y -value of 10 corresponds to the absence of nodules with a diameter of $23\ \mu\text{m}$ or larger. A rating of 1 would mean that there are a large number of large agglomerates near the surface.)

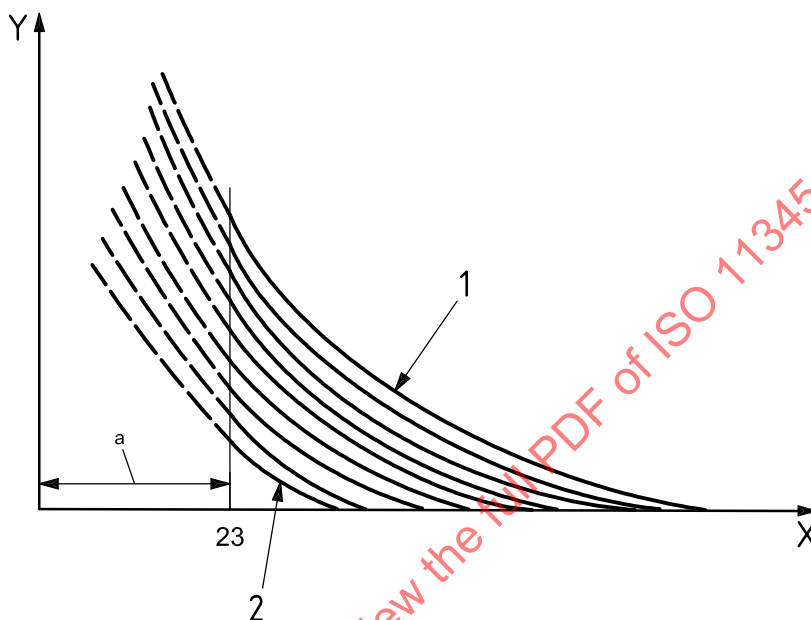

Key

- X agglomerate size, μm
- Y number of agglomerates
- 1 rubber compound with high agglomerate count (low y -value)
- 2 rubber compound with low agglomerate count (high y -value)
- ^a Agglomerate sizes which can be ignored.

Figure 4 — Agglomerate count (y -value)

10.2 Apparatus

10.2.1 Razor blade, with a single edge, attached to a sample cutter.

10.2.2 Sample cutter comprising a razor blade holder and a lever mechanism which provides a vertical cutting action.

10.2.3 Equipment for split-field representation: The instrument is based on the equipment described in 7.2.3. In this method, image-processing software is also required to detect the surface nodules. It shall be possible to calibrate the equipment to ensure that the illumination is uniform and that the light intensity can be maintained at a fixed level. The calibration system shall be such as to eliminate variations in the optical and analogue electronic components of the equipment. It shall also ensure that gradual dust deposition on the optical components of the equipment is compensated for.

10.3 Test piece

Prepare the test piece for method E in the same manner as described in 6.3.

10.4 Procedure

Switch on the instrument and allow it to warm up for the specified time.

Place the test piece with the freshly cut surface resting against the test piece holder. The test piece shall be placed in the same way as it was in the cutter, with the cutting direction vertical.

Examine the prepared test piece in the instrument with oblique illumination (at an angle of incidence of 30°). Scan the surface using the image-processing software to obtain a histogram showing the size and frequency of the surface nodules in the test piece (showing up as bumps or depressions). Disregard all surface nodules with a diameter below 23 µm. The areas of the remaining nodules are added together to give the total white area. This area is divided by the total test area to obtain the percentage of the whole test area that is covered by these nodules. This percentage is then converted into a numerical rating using Table 1.

Assign to each compound being assessed the most closely matching numerical rating, using whole numbers. For closer matching, use fractional ratings.

A rating of 10 indicates the absence of surface nodules with a diameter of 23 µm or larger, while a rating of 1 indicates a large number of such agglomerates.

11 Test report

The test report shall include the following information:

- a) a reference to this International Standard;
- b) all details necessary for complete identification of the material examined, including type, whether vulcanized or unvulcanized, source, manufacturer's code number and previous history;
- c) whether method A, B, C, D or E was used;
- d) the rating determined on the scale of 1 to 10, using fractional ratings where necessary (if more than one operator has rated the material, report the number of observations and the average rating);
- e) the date of the test.

Annex A (normative)

Visual dispersion rating vs dispersion classification at × 30 magnification (methods A and B)

General methods suitable for compounds with any type of carbon black.

The number beside each photo indicates the rating.

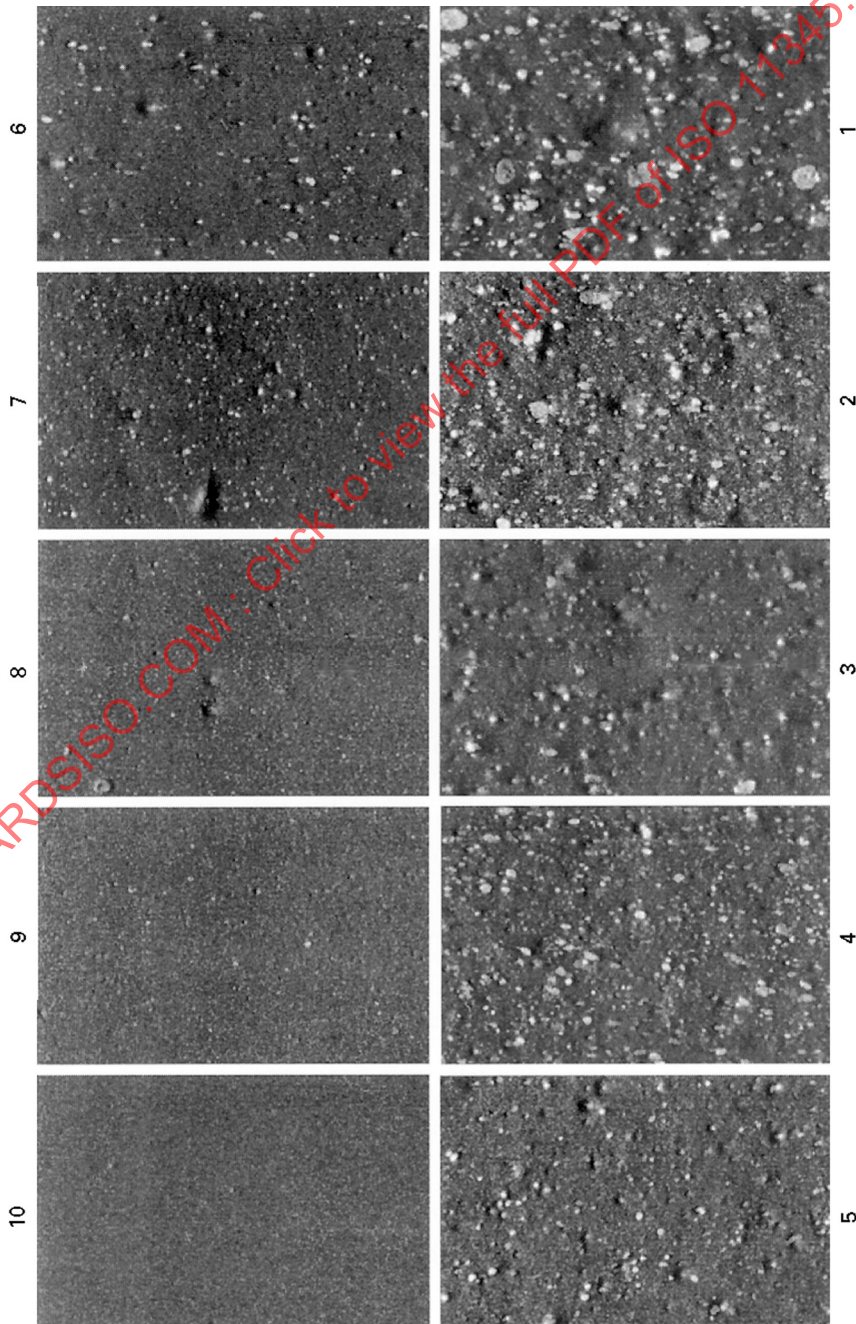



Annex B
(normative)

**Visual dispersion rating vs dispersion classification at
× 100 magnification — Carbon black (CB)**

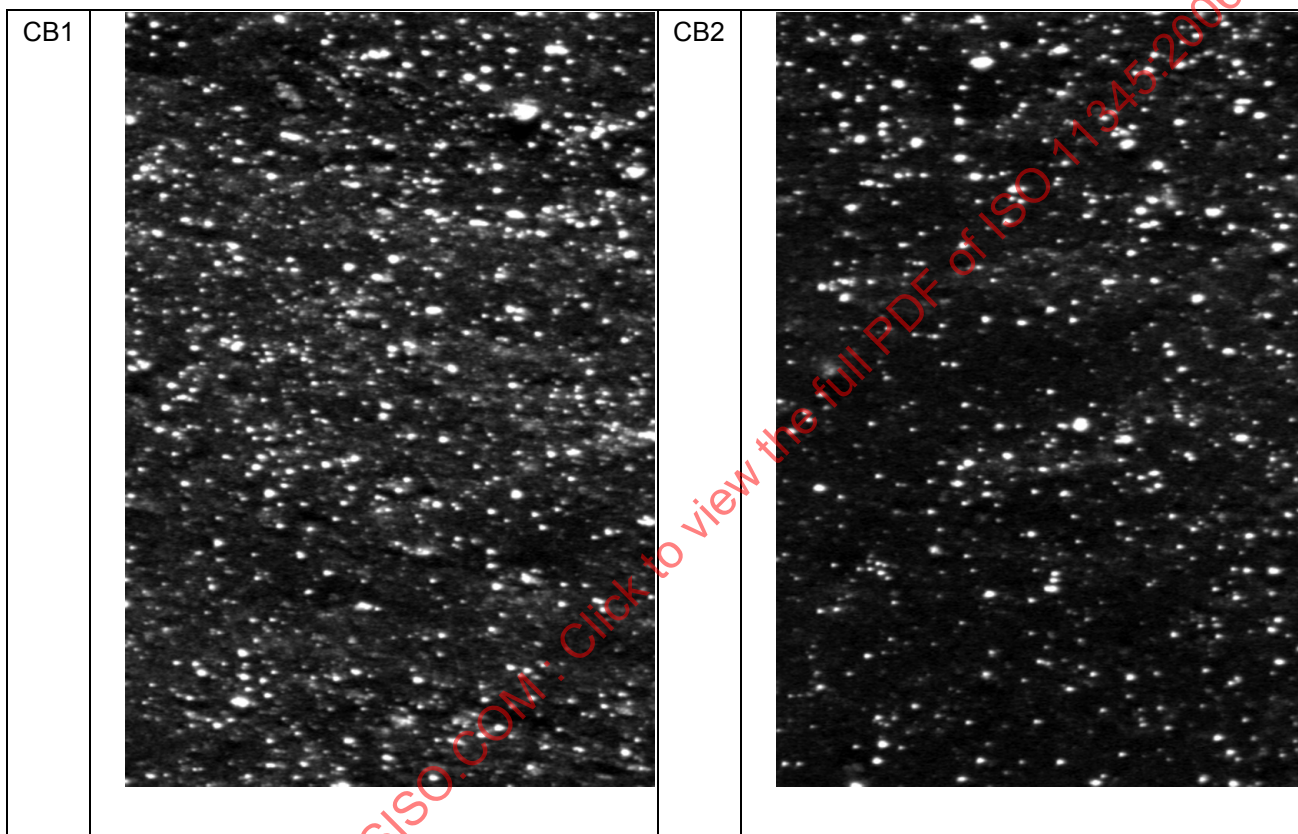
Reference images suitable for compounds with any type of carbon black.

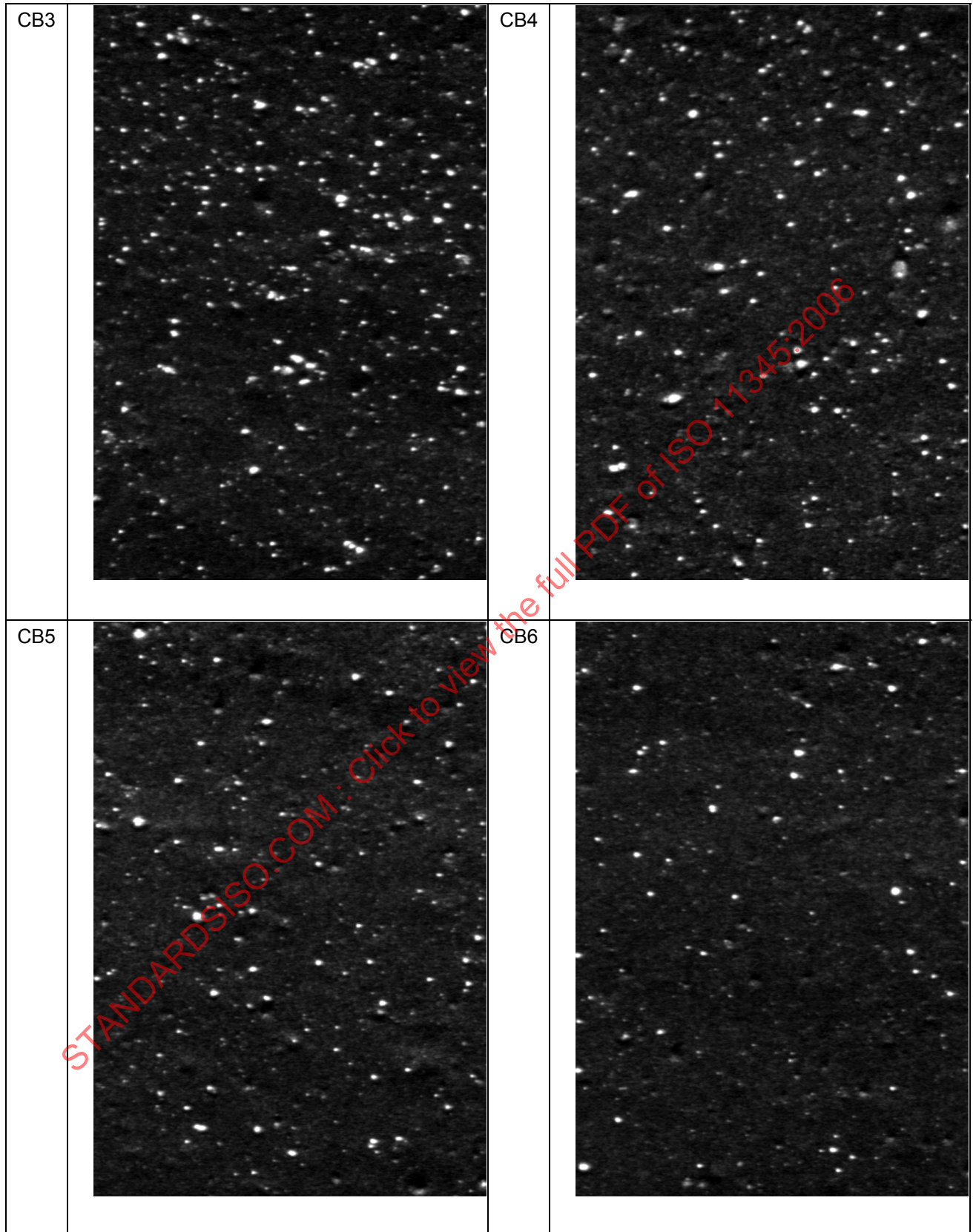

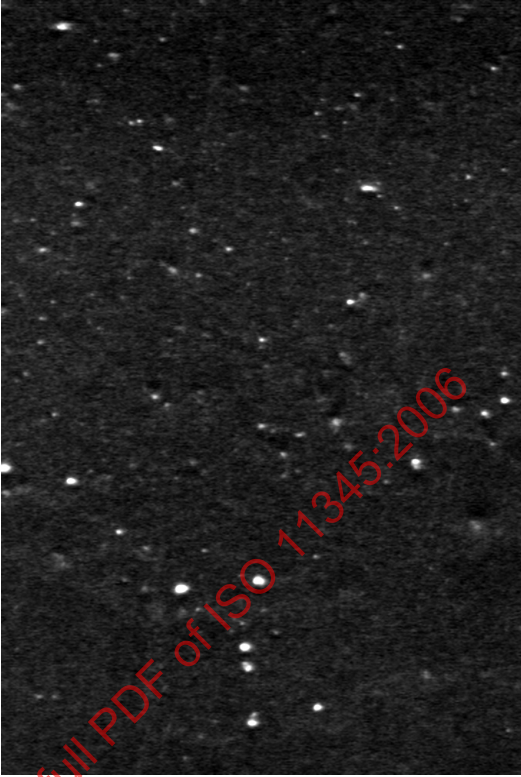
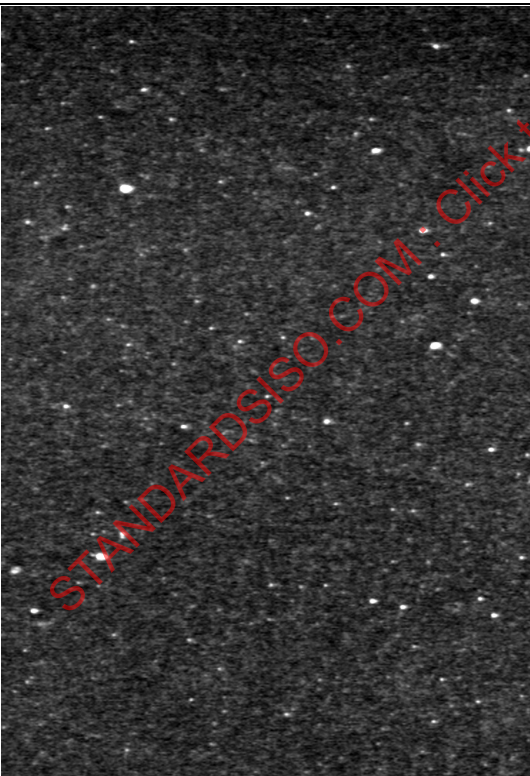
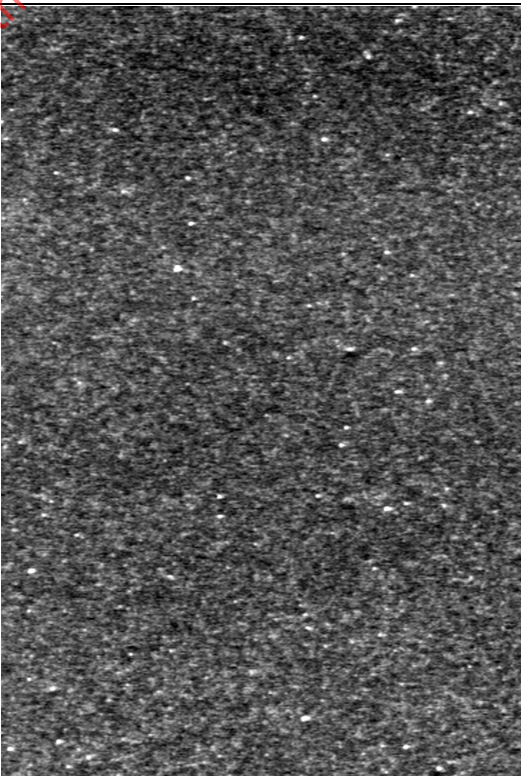

| | | | |
|-----|---|------|--|
| CB7 |  | CB8 |  |
| CB9 |  | CB10 |  |

Annex C (normative)

Visual dispersion rating vs dispersion classification at × 100 magnification — Reinforcing carbon black (RCB)

Increased resolution for compounds containing reinforcing carbon blacks.

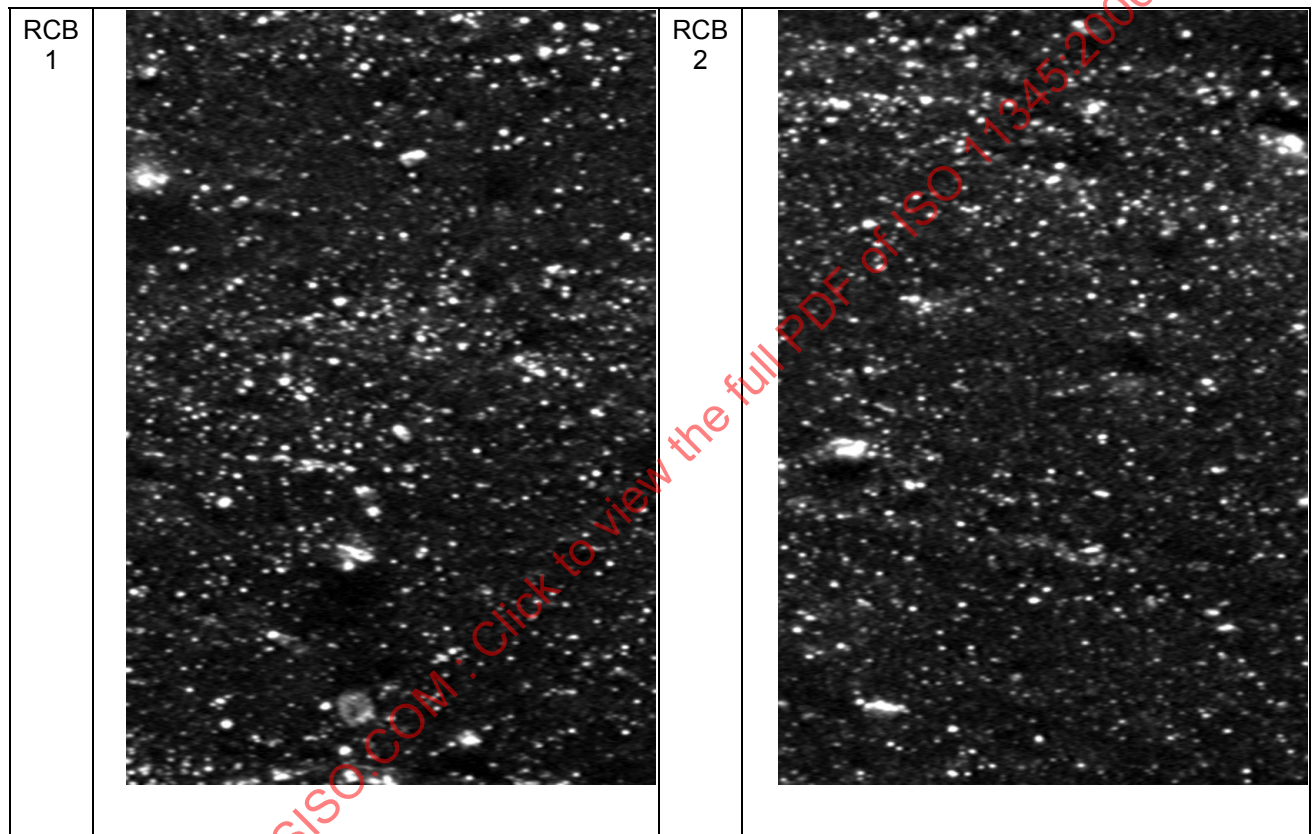

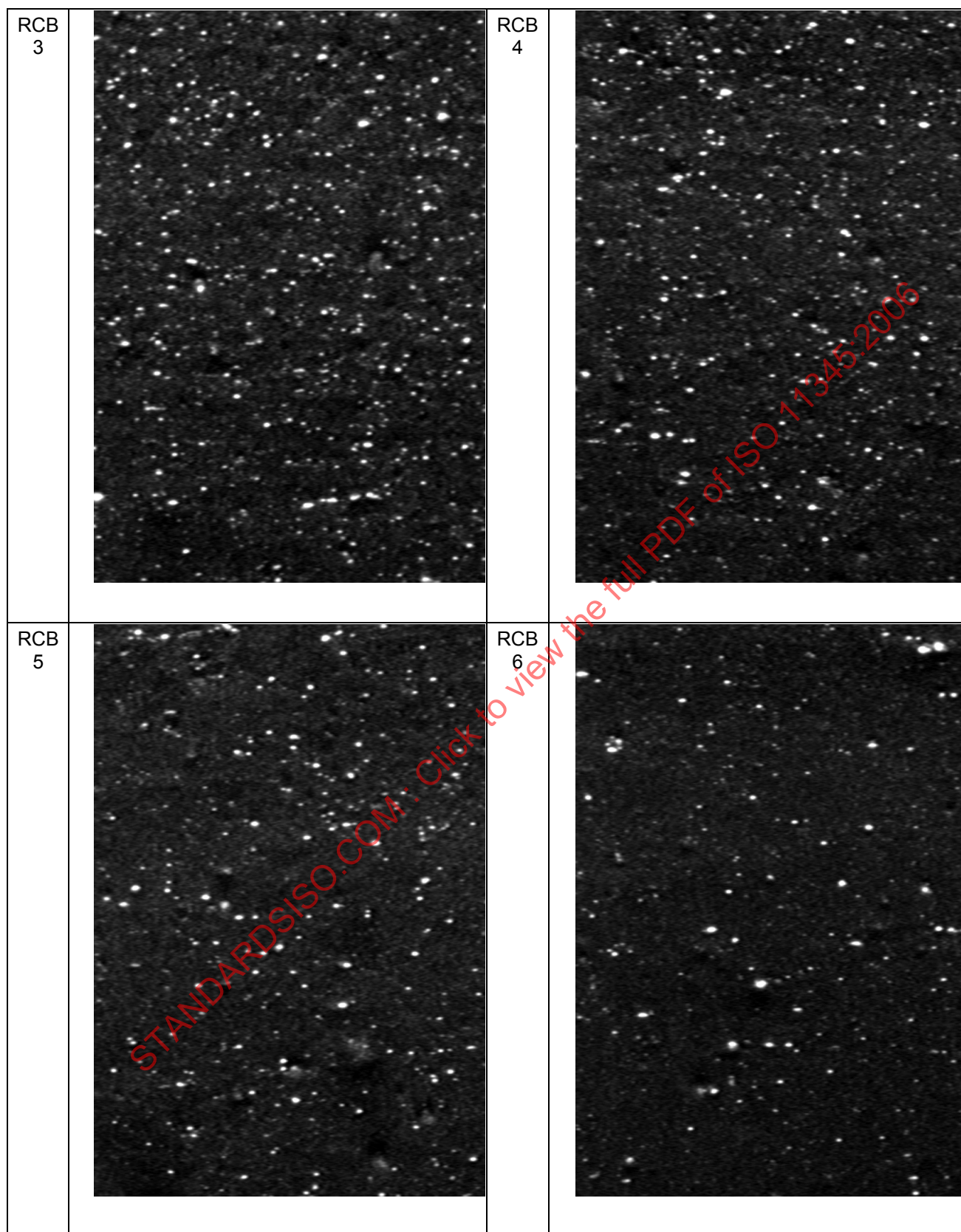

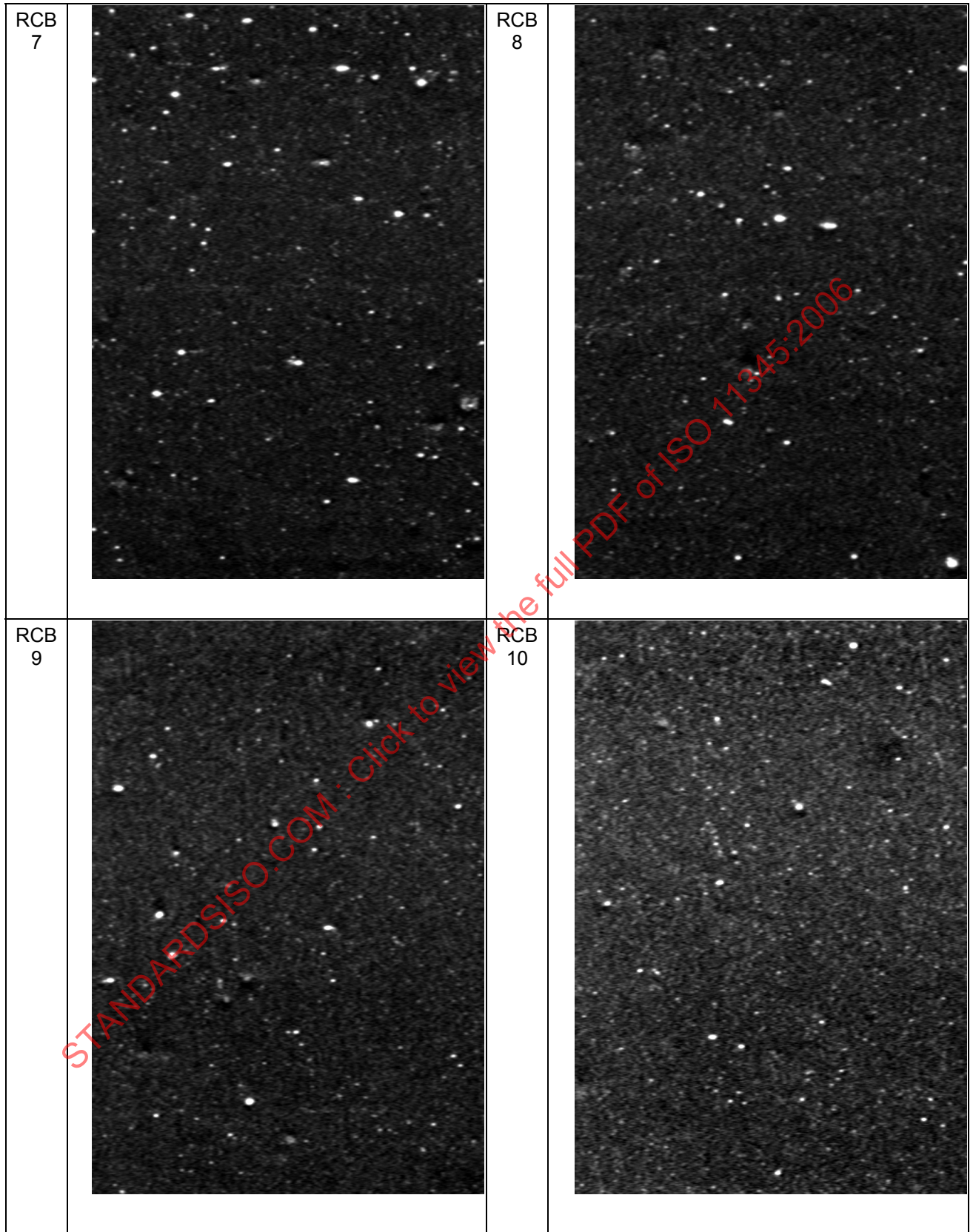

Annex D
(informative)

**Visual dispersion rating vs dispersion classification at
× 100 magnification — Reinforcing carbon black with silica (RCB/Silica)**

Increased resolution for compounds containing reinforcing carbon blacks and a high load of silica.

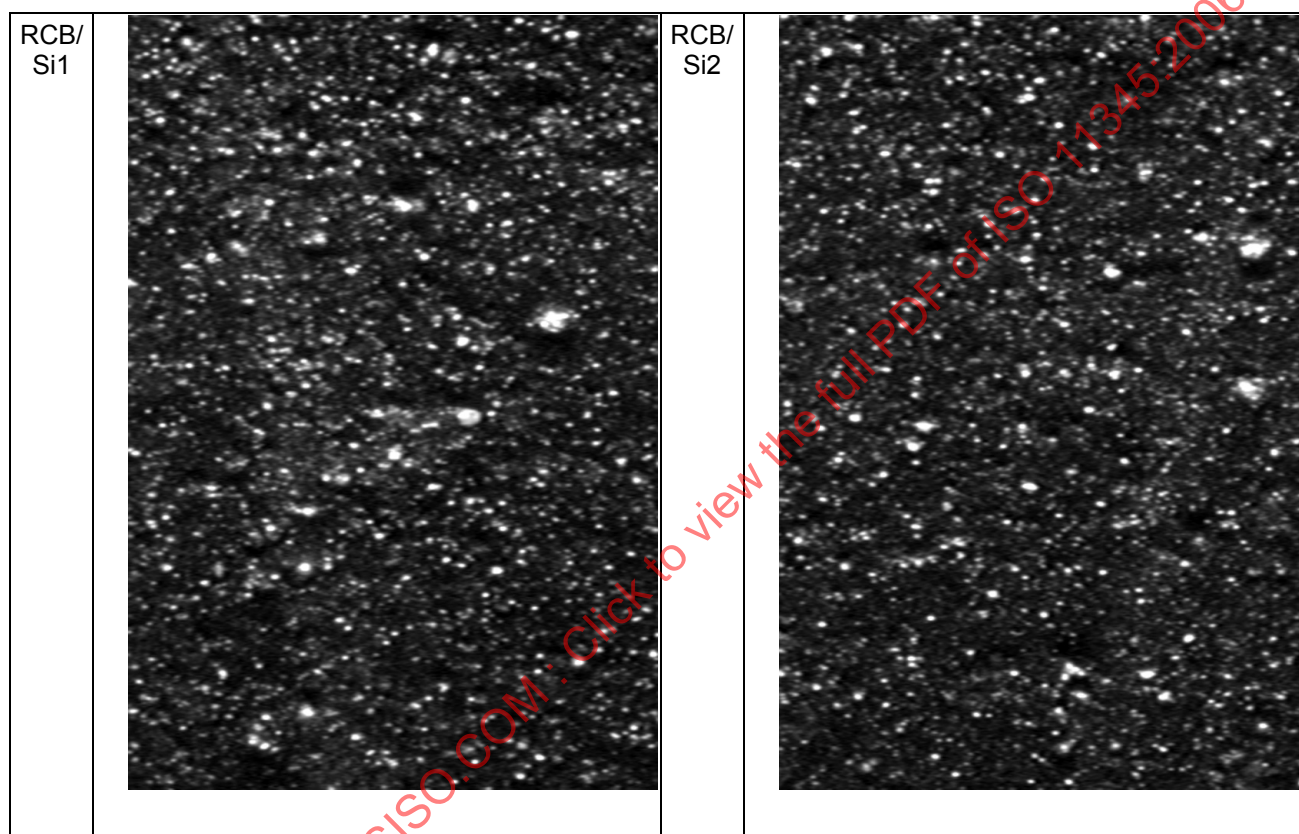

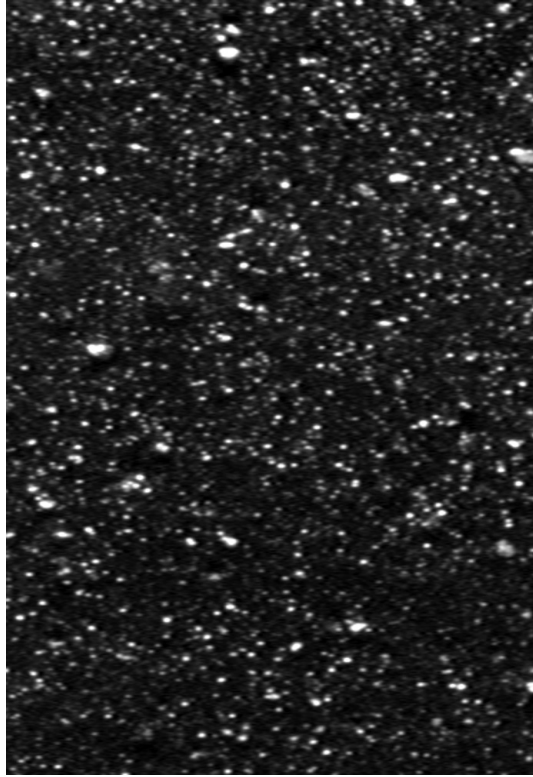
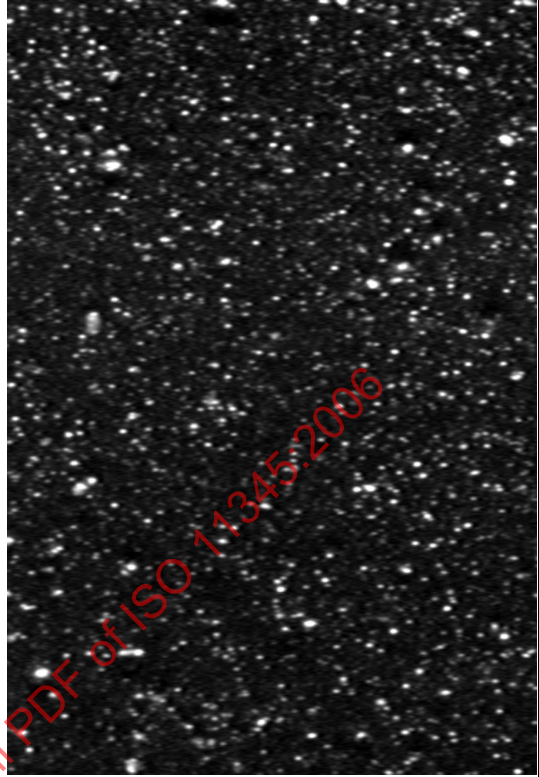
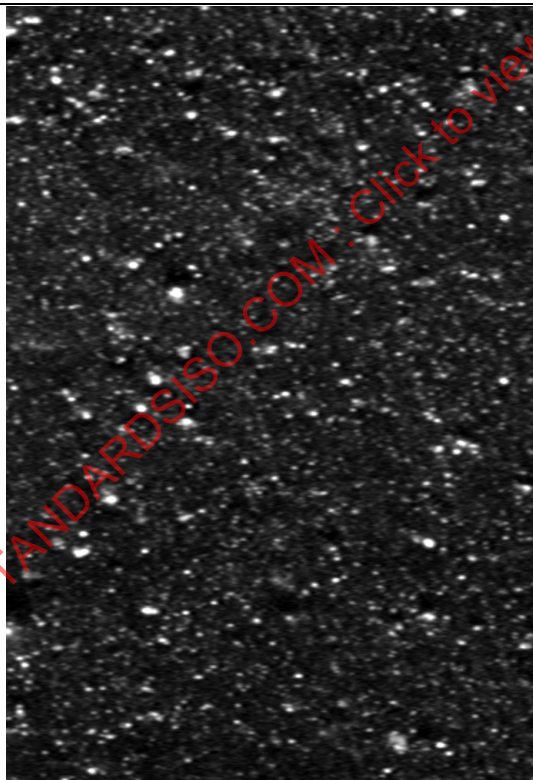
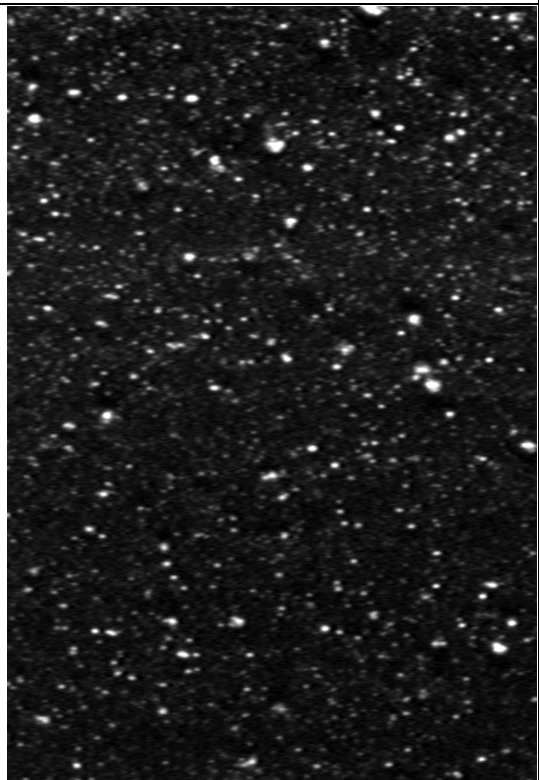
| | | | |
|---------------------|---|---------------------|--|
| <p>RCB/ Si3</p> |  | <p>RCB/ Si4</p> |  |
| <p>RCB/ Si5</p> |  | <p>RCB/ Si6</p> |  |

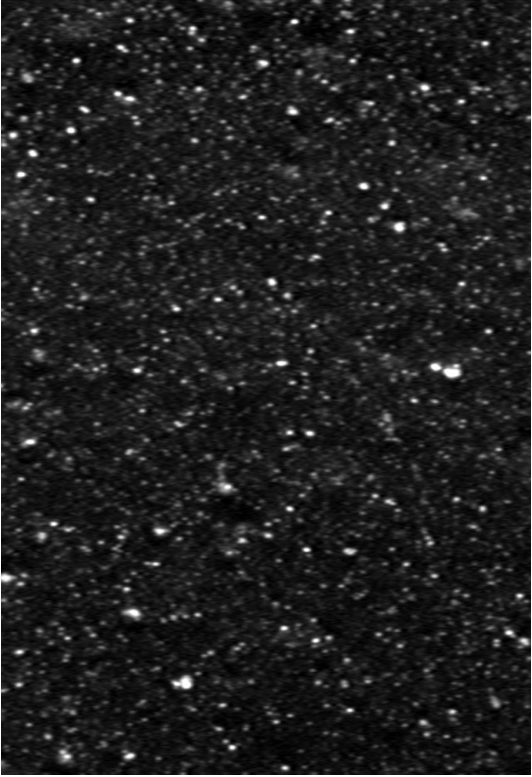
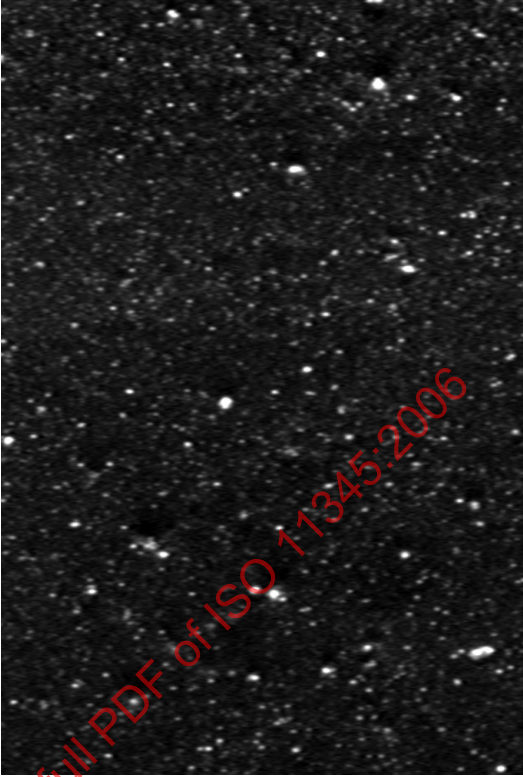
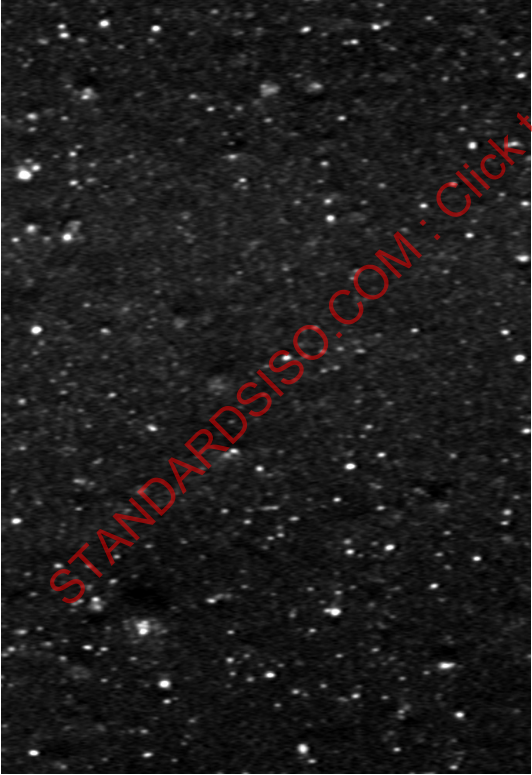
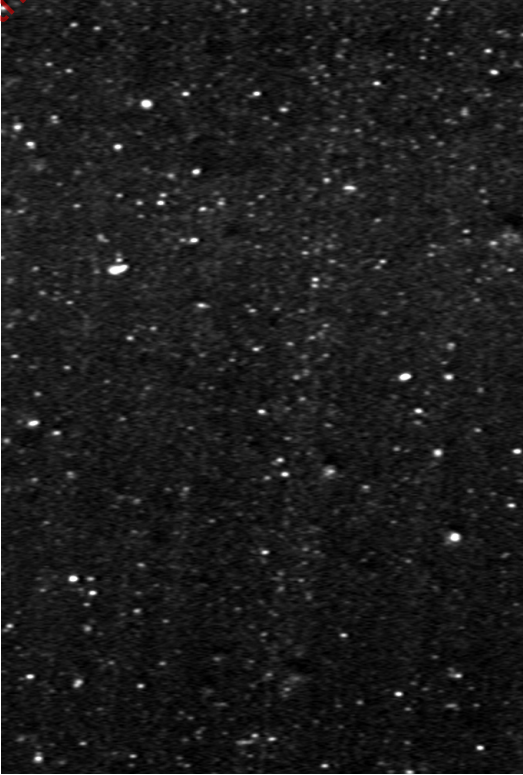
| | | | |
|-------------|---|--------------|--|
| RCB/ Si7 |  | RCB/ Si8 |  |
| RCB/ Si9 |  | RCB/ Si10 |  |

Annex E (normative)

Visual dispersion rating vs dispersion classification at × 100 magnification — Semi-reinforcing carbon black (SRCB)

Increased resolution for compounds containing semi-reinforcing carbon blacks.

