

---

---

**Petroleum and natural gas industries —  
Design and operation of subsea  
production systems**

Part 4:  
**Subsea wellhead and tree equipment**

*Industries du pétrole et du gaz naturel — Conception et exploitation des  
systèmes de production immergés*

*Partie 4: Équipements immergés de tête de puits et tête de production*

STANDARDSISO.COM : Click to view the full PDF of ISO 13628-4:2010



**PDF disclaimer**

This PDF file may contain embedded typefaces. In accordance with Adobe's licensing policy, this file may be printed or viewed but shall not be edited unless the typefaces which are embedded are licensed to and installed on the computer performing the editing. In downloading this file, parties accept therein the responsibility of not infringing Adobe's licensing policy. The ISO Central Secretariat accepts no liability in this area.

Adobe is a trademark of Adobe Systems Incorporated.

Details of the software products used to create this PDF file can be found in the General Info relative to the file; the PDF-creation parameters were optimized for printing. Every care has been taken to ensure that the file is suitable for use by ISO member bodies. In the unlikely event that a problem relating to it is found, please inform the Central Secretariat at the address given below.

STANDARDSISO.COM : Click to view the full PDF of ISO 13628-4:2010



**COPYRIGHT PROTECTED DOCUMENT**

© ISO 2010

All rights reserved. Unless otherwise specified, no part of this publication may be reproduced or utilized in any form or by any means, electronic or mechanical, including photocopying and microfilm, without permission in writing from either ISO at the address below or ISO's member body in the country of the requester.

ISO copyright office  
Case postale 56 • CH-1211 Geneva 20  
Tel. + 41 22 749 01 11  
Fax + 41 22 749 09 47  
E-mail [copyright@iso.org](mailto:copyright@iso.org)  
Web [www.iso.org](http://www.iso.org)

Published in Switzerland

# Contents

Page

Foreword .....	v
Introduction.....	vi
<b>1</b> <b>Scope</b> .....	<b>1</b>
<b>2</b> <b>Normative references</b> .....	<b>4</b>
<b>3</b> <b>Terms, definitions, abbreviated terms and symbols</b> .....	<b>5</b>
3.1 <b>Terms and definitions</b> .....	<b>5</b>
3.2 <b>Abbreviated terms and symbols</b> .....	<b>10</b>
<b>4</b> <b>Service conditions and production specification levels</b> .....	<b>12</b>
4.1 <b>Service conditions</b> .....	<b>12</b>
4.2 <b>Product specification levels</b> .....	<b>13</b>
<b>5</b> <b>Common system requirements</b> .....	<b>13</b>
5.1 <b>Design and performance requirements</b> .....	<b>13</b>
5.2 <b>Materials</b> .....	<b>25</b>
5.3 <b>Welding</b> .....	<b>26</b>
5.4 <b>Quality control</b> .....	<b>27</b>
5.5 <b>Equipment marking</b> .....	<b>30</b>
5.6 <b>Storing and shipping</b> .....	<b>31</b>
<b>6</b> <b>General design requirements for subsea trees and tubing hangers</b> .....	<b>32</b>
6.1 <b>General</b> .....	<b>32</b>
6.2 <b>Tree valving</b> .....	<b>34</b>
6.3 <b>Testing of subsea tree assemblies</b> .....	<b>42</b>
6.4 <b>Marking</b> .....	<b>47</b>
6.5 <b>Storing and shipping</b> .....	<b>47</b>
<b>7</b> <b>Specific requirements — Subsea-tree-related equipment and sub assemblies</b> .....	<b>47</b>
7.1 <b>Flanged end and outlet connections</b> .....	<b>47</b>
7.2 <b>ISO clamp hub-type connections</b> .....	<b>65</b>
7.3 <b>Threaded connections</b> .....	<b>65</b>
7.4 <b>Other end connectors</b> .....	<b>65</b>
7.5 <b>Studs, nuts and bolting</b> .....	<b>66</b>
7.6 <b>Ring gaskets</b> .....	<b>66</b>
7.7 <b>Completion guidebase</b> .....	<b>67</b>
7.8 <b>Tree connectors and tubing heads</b> .....	<b>68</b>
7.9 <b>Tree stab/seal subs for vertical tree</b> .....	<b>72</b>
7.10 <b>Valves, valve blocks and actuators</b> .....	<b>73</b>
7.11 <b>TFL wye spool and diverter</b> .....	<b>86</b>
7.12 <b>Re-entry interface</b> .....	<b>87</b>
7.13 <b>Subsea tree cap</b> .....	<b>88</b>
7.14 <b>Tree-cap running tool</b> .....	<b>91</b>
7.15 <b>Tree-guide frame</b> .....	<b>93</b>
7.16 <b>Tree running tool</b> .....	<b>97</b>
7.17 <b>Tree piping</b> .....	<b>100</b>
7.18 <b>Flowline connector systems</b> .....	<b>102</b>
7.19 <b>Ancillary equipment running tools</b> .....	<b>105</b>
7.20 <b>Tree-mounted hydraulic/electric/optical control interfaces</b> .....	<b>107</b>
7.21 <b>Subsea chokes and actuators</b> .....	<b>110</b>
7.22 <b>Miscellaneous equipment</b> .....	<b>121</b>
<b>8</b> <b>Specific requirements — Subsea wellhead</b> .....	<b>125</b>
8.1 <b>General</b> .....	<b>125</b>

8.2	Temporary guidebase .....	126
8.3	Permanent guidebase .....	127
8.4	Conductor housing .....	131
8.5	Wellhead housing .....	134
8.6	Casing hangers .....	137
8.7	Annulus seal assemblies .....	140
8.8	Casing hanger lockdown bushing .....	141
8.9	Bore protectors and wear bushings .....	142
8.10	Corrosion cap .....	144
8.11	Running, retrieving and testing tools .....	144
8.12	Trawl protective structure .....	144
8.13	Wellhead inclination and orientation .....	144
8.14	Submudline casing hanger and seal assemblies .....	145
9	Specific requirements — Subsea tubing hanger system .....	146
9.1	General .....	146
9.2	Design .....	146
9.3	Materials .....	149
9.4	Testing .....	149
10	Specific requirements — Mudline suspension equipment .....	150
10.1	General .....	150
10.2	Mudline suspension-landing/elevation ring .....	154
10.3	Casing hangers .....	155
10.4	Casing hanger running tools and tieback adapters .....	156
10.5	Abandonment caps .....	157
10.6	Mudline conversion equipment for subsea completions .....	157
10.7	Tubing hanger system — Mudline conversion equipment for subsea completions .....	158
11	Specific requirements — Drill-through mudline suspension equipment .....	159
11.1	General .....	159
11.2	External drill-through casing hangers (outside of the hybrid casing hanger housing) .....	159
11.3	Hybrid casing hanger housing .....	159
11.4	Internal drill-through mudline casing hangers .....	161
11.5	Annulus seal assemblies .....	163
11.6	Bore protectors and wear bushings .....	164
11.7	Tubing hanger system — Drill-through mudline equipment for subsea completions .....	166
11.8	Abandonment caps .....	166
11.9	Running, retrieving and testing tools .....	166
Annex A (informative)	Vertical subsea trees .....	167
Annex B (informative)	Horizontal subsea trees .....	171
Annex C (informative)	Subsea wellhead .....	174
Annex D (informative)	Subsea tubing hanger .....	176
Annex E (normative)	Mudline suspension and conversion systems .....	180
Annex F (informative)	Drill-through mudline suspension systems .....	187
Annex G (informative)	Assembly guidelines of ISO (API) bolted flanged connections .....	189
Annex H (informative)	Design and testing of subsea wellhead running, retrieving and testing tools ..	199
Annex I (informative)	Procedure for the application of a coating system .....	202
Annex J (informative)	Screening tests for material compatibility .....	205
Annex K (informative)	Design and testing of pad eyes for lifting .....	210
Annex L (informative)	Hyperbaric testing guidelines .....	225
Annex M (informative)	Purchasing guidelines .....	227
Bibliography	.....	249

## Foreword

ISO (the International Organization for Standardization) is a worldwide federation of national standards bodies (ISO member bodies). The work of preparing International Standards is normally carried out through ISO technical committees. Each member body interested in a subject for which a technical committee has been established has the right to be represented on that committee. International organizations, governmental and non-governmental, in liaison with ISO, also take part in the work. ISO collaborates closely with the International Electrotechnical Commission (IEC) on all matters of electrotechnical standardization.

International Standards are drafted in accordance with the rules given in the ISO/IEC Directives, Part 2.

The main task of technical committees is to prepare International Standards. Draft International Standards adopted by the technical committees are circulated to the member bodies for voting. Publication as an International Standard requires approval by at least 75 % of the member bodies casting a vote.

Attention is drawn to the possibility that some of the elements of this document may be the subject of patent rights. ISO shall not be held responsible for identifying any or all such patent rights.

ISO 13628-4 was prepared by Technical Committee ISO/TC 67, *Materials, equipment and offshore structures for petroleum, petrochemical and natural gas industries*, Subcommittee SC 4, *Drilling and production equipment*.

This second edition cancels and replaces the first edition (ISO 13628-4:1999), which has been technically revised.

ISO 13628 consists of the following parts, under the general title *Petroleum and natural gas industries — Design and operation of subsea production systems*:

- *Part 1: General requirements and recommendations*
- *Part 2: Unbonded flexible pipe systems for subsea and marine applications*
- *Part 3: Through flowline (TFL) systems*
- *Part 4: Subsea wellhead and tree equipment*
- *Part 5: Subsea umbilicals*
- *Part 6: Subsea production control systems*
- *Part 7: Completion/workover riser systems*
- *Part 8: Remotely Operated Vehicle (ROV) interfaces on subsea production systems*
- *Part 9: Remotely Operated Tool (ROT) intervention systems*
- *Part 10: Specification for bonded flexible pipe*
- *Part 11: Flexible pipe systems for subsea and marine applications*

A part 12, dealing with dynamic production risers, a part 14, dealing with High Integrity Pressure Protections Systems (HIPPS), a part 15, dealing with subsea structures and manifolds, a part 16, dealing with specifications for flexible pipe ancillary equipment, and a part 17, dealing with recommended practice for flexible pipe ancillary equipment, are under development.

## Introduction

This second edition of ISO 13628-4 has been updated by users and manufacturers of subsea wellheads and trees. Particular attention was paid to making it an auditable standard. It is intended for worldwide application in the petroleum industry. It is not intended to replace sound engineering judgement. It is necessary that users of this part of ISO 13628 be aware that additional or different requirements can better suit the demands of a particular service environment, the regulations of a jurisdictional authority or other scenarios not specifically addressed.

A major effort in developing this second edition was a study of the risks and benefits of penetrations in subsea wellheads. All previous editions of both this part of ISO 13628 and its parallel API document *Specification for Subsea Wellhead and Christmas Tree Equipment* (Specification 17D) prohibited wellhead penetrations. However, that prohibition was axiomatic. In developing this second edition, the workgroup used qualitative risk analysis techniques and found that the original insight was correct: subsea wellheads with penetrations are more than twice as likely to develop leaks over their life as those without penetrations.

The catalyst for examining this portion of the original editions of the API and ISO standards was the phenomenon of casing pressure and its monitoring in subsea wells. The report generated by the aforementioned risk analysis has become API 17 TR3 and API RP 90. The workgroup encourages the use of these documents when developing designs and operating practices for subsea wells.

Care has also been taken to address the evolving issue of using external hydrostatic pressure in design. The original versions of both API 17D and ISO 13628-4 were adopted at a time when the effects of that parameter were relatively small. The industry's move into greater water depths has prompted a consideration of that aspect in this version of this part of ISO 13628. The high-level view is that it is not appropriate to use external hydrostatic pressure to augment the applications for which a component can be used. For example, this part of ISO 13628 does not allow the use of a subsea tree rated for 69 MPa (10 000 psi) installed in 2 438 m (8 000 ft) of water on a well that has a shut-in tubing pressure greater than 69 MPa (10 000 psi). See 5.1.2.1.1 for further guidance.

The design considerations involved in using external hydrostatic pressure are only currently becoming fully understood. If a user or fabricator desires to explore these possibilities, it is recommended that a thorough review of the forthcoming American Petroleum Institute technical bulletin on the topic be carefully studied.

The overall objective of this part of ISO 13628 is to define clear and unambiguous requirements that facilitate international standardization in order to enable safe and economic development of offshore oil and gas fields by the use of subsea wellhead and tree equipment. It is written in a manner that allows the use of a wide variety of technology, from well established to state-of-the-art. The contributors to this update do not wish to restrict or deter the development of new technology. However, the user of this part of ISO 13628 is encouraged to closely examine standard interfaces and the reuse of intervention systems and tools in the interests of minimizing life-cycle costs and increasing reliability through the use of proven interfaces.

It is important that users of this part of ISO 13628 be aware that further or differing requirements can be needed for individual applications. This part of ISO 13628 is not intended to inhibit a vendor from offering, or the purchaser from accepting, alternative equipment or engineering solutions for the individual application. This can be particularly applicable where there is innovative or developing technology. Where an alternative is offered, it is the responsibility of the vendor to identify any variations from this part of ISO 13628 and provide details.

# Petroleum and natural gas industries — Design and operation of subsea production systems

## Part 4: Subsea wellhead and tree equipment

### 1 Scope

This part of ISO 13628 provides specifications for subsea wellheads, mudline wellheads, drill-through mudline wellheads and both vertical and horizontal subsea trees. It specifies the associated tooling necessary to handle, test and install the equipment. It also specifies the areas of design, material, welding, quality control (including factory acceptance testing), marking, storing and shipping for both individual sub-assemblies (used to build complete subsea tree assemblies) and complete subsea tree assemblies.

The user is responsible for ensuring subsea equipment meets any additional requirements of governmental regulations for the country in which it is installed. This is outside the scope of this part of ISO 13628.

Where applicable, this part of ISO 13628 can also be used for equipment on satellite, cluster arrangements and multiple well template applications.

Equipment that is within the scope of this part of ISO 13628 is listed as follows:

- a) subsea trees:
- tree connectors and tubing hangers,
  - valves, valve blocks, and valve actuators,
  - chokes and choke actuators,
  - bleed, test and isolation valves,
  - TFL wye spool,
  - re-entry interface,
  - tree cap,
  - tree piping,
  - tree guide frames,
  - tree running tools,
  - tree cap running tools,
  - tree mounted flowline/umbilical connector,
  - tubing heads and tubing head connectors,

- flowline bases and running/retrieval tools,
  - tree mounted controls interfaces (instrumentation, sensors, hydraulic tubing/piping and fittings, electrical controls cable and fittings);
- b) subsea wellheads:
- conductor housings,
  - wellhead housings,
  - casing hangers,
  - seal assemblies,
  - guidebases,
  - bore protectors and wear bushings,
  - corrosion caps;
- c) mudline suspension systems:
- wellheads,
  - running tools,
  - casing hangers,
  - casing hanger running tool,
  - tieback tools for subsea completion,
  - subsea completion adaptors for mudline wellheads,
  - tubing heads,
  - corrosion caps;
- d) drill through mudline suspension systems:
- conductor housings,
  - surface casing hangers,
  - wellhead housings,
  - casing hangers,
  - annulus seal assemblies,
  - bore protectors and wear bushings,
  - abandonment caps;



- e) tubing hanger systems:
  - tubing hangers,
  - running tools;
- f) miscellaneous equipment:
  - flanged end and outlet connections,
  - clamp hub-type connections,
  - threaded end and outlet connections,
  - other end connections,
  - studs and nuts,
  - ring joint gaskets,
  - guideline establishment equipment.

This part of ISO 13628 includes equipment definitions, an explanation of equipment use and function, an explanation of service conditions and product specification levels, and a description of critical components, i.e. those parts having requirements specified in this part of ISO 13628.

The following equipment is outside the scope of this part of ISO 13628:

- subsea wireline/coiled tubing BOPs;
- installation, workover, and production risers;
- subsea test trees (landing strings);
- control systems and control pods;
- platform tiebacks;
- primary protective structures;
- subsea process equipment;
- subsea manifolding and jumpers;
- subsea wellhead tools;
- repair and rework;
- multiple well template structures;
- mudline suspension high pressure risers;
- template piping;
- template interfaces.

This part of ISO 13628 is not applicable to the rework and repair of used equipment.

## 2 Normative references

The following referenced documents are indispensable for the application of this document. For dated references, only the edition cited applies. For undated references, the latest edition of the referenced document (including any amendments) applies.

ISO 8501-1, *Preparation of steel substrates before application of paints and related products — Visual assessment of surface cleanliness — Part 1: Rust grades and preparation grades of uncoated steel substrates and of steel substrates after overall removal of previous coatings*

ISO 10423, *Petroleum and natural gas industries — Drilling and production equipment — Wellhead and christmas tree equipment*

ISO 10424-1, *Petroleum and natural gas industries — Rotary drilling equipment — Part 1: Rotary drill stem elements*

ISO 11960, *Petroleum and natural gas industries — Steel pipes for use as casing or tubing for wells*

ISO 13625, *Petroleum and natural gas industries — Drilling and production equipment — Marine drilling riser couplings*

ISO 13628-1, *Petroleum and natural gas industries — Design and operation of subsea production systems — Part 1: General requirements and recommendations*

ISO 13628-3, *Petroleum and natural gas industries — Design and operation of subsea production systems — Part 3: Through flowline (TFL) systems*

ISO 13628-7, *Petroleum and natural gas industries — Design and operation of subsea production systems — Part 7: Completion/workover riser systems*

ISO 13628-8, *Petroleum and natural gas industries — Design and operation of subsea production systems — Part 8: Remotely Operated Vehicle (ROV) interfaces on subsea production systems*

ISO 13628-9, *Petroleum and natural gas industries — Design and operation of subsea production systems — Part 9: Remotely Operated Tool (ROT) intervention systems*

ISO 13533, *Petroleum and natural gas industries — Drilling and production equipment — Drill-through equipment*

ISO 15156 (all parts), *Petroleum and natural gas industries — Materials for use in H<sub>2</sub>S-containing environments in oil and gas production*

ANSI/ASME B16.11, *Forged Fittings, Socket-Welding and Threaded*

ANSI/ASME B31.3, *Process Piping*

ANSI/ASME B31.4, *Pipeline Transportation Systems for Liquid Hydrocarbons and Other Liquids*

ANSI/ASME B31.8, *Gas Transmission and Distribution Piping Systems*

ANSI/ISA 75.02, *Control Valve Capacity Test Procedure*

ANSI/SAE J517, *Hydraulic Hose Fittings*

ANSI/SAE J343, *Test and Test Procedures for SAE 100R Series Hydraulic Hose and Hose Assemblies*

API Spec 5B, *Specification for Threading, Gauging, and Thread Inspection of Casing, Tubing, and Line Pipe Threads (US Customary Units)*

ASTM D1414, *Standard Test Methods for Rubber O-Rings*

DNV RP B401, *Cathodic Protection Design*

ISA 75.01.01, *Flow Equations for Sizing Control Valves*

NACE No. 2/SSPC-SP 10, *Joint Surface Preparation Standard: Near-White Metal Blast Cleaning*

NACE SP0176, *Corrosion Control of Submerged Areas of Permanently Installed Steel Offshore Structures Associated With Petroleum Production*

SAE/AS 4059, *Aerospace Fluid Power — Cleanliness Classification for Hydraulic Fluids*

### 3 Terms, definitions, abbreviated terms and symbols

#### 3.1 Terms and definitions

For the purposes of this document, the following terms and definitions apply.

##### 3.1.1

##### **annulus seal assembly**

mechanism that provides pressure isolation between each casing hanger and the wellhead housing

##### 3.1.2

##### **backdriving**

⟨general⟩ an unplanned movement in the reverse direction of an operation

##### 3.1.3

##### **backdriving**

⟨linear actuator⟩ condition where the valve drifts from the set position

##### 3.1.4

##### **backdriving**

⟨manual/ROV operated choke⟩ condition where the valve changes position after the operator is disengaged

##### 3.1.5

##### **backdriving**

⟨rotary actuator⟩ condition where the valve continues to change position subsequent to the completion of a positional movement

##### 3.1.6

##### **backdriving**

⟨stepping-actuated choke⟩ condition where the valve changes position after the operator is disengaged

##### 3.1.7

##### **bore protector**

device that protects internal bore surfaces during drilling or workover operations

##### 3.1.8

##### **check valve**

device designed to prevent flow in one direction

##### 3.1.9

##### **choke**

equipment used to restrict and control the flow of fluids and gas

**3.1.10**

**completion/workover riser**

extension of the production and/or annulus bore(s) of a subsea well to a surface vessel

See ISO 13628-7.

**3.1.11**

**conductor housing**

top of the first casing string, which forms the basic foundation of the subsea wellhead and provides attachments for guidance structures

**3.1.12**

**corrosion cap**

cap placed over the wellhead to protect it from contamination by debris, marine growth or corrosion during temporary abandonment of the well

**3.1.13**

**corrosion-resistant alloy**

**CRA**

non-ferrous alloy for which any one or the sum of the specified amount of the following alloy elements exceeds 50 %: titanium, nickel, cobalt, chromium and molybdenum

NOTE This term refers to corrosion-resistant alloys and not cracking-resistant alloys as mentioned in ISO 15156 (all parts).

**3.1.14**

**corrosion-resistant material**

**CRM**

ferrous or non-ferrous alloy that is more corrosion resistant than low-alloy steels

NOTE This term includes: CRAs, duplex, and stainless steels.

**3.1.15**

**depth rating**

maximum rated working depth for a piece of equipment at a given set of operating conditions

**3.1.16**

**downstream**

direction of movement away from the reservoir

**3.1.17**

**equipment**

any item or assembly to which ISO 13628-4 is applicable

**3.1.18**

**extension sub**

sealing tubular member that provides tree-bore continuity between adjacent tree components

**3.1.19**

**fail-closed valve**

actuated valve designed to fail to the closed position

**3.1.20**

**fail-open valve**

actuated valve designed to fail to the open position

**3.1.21**

**flowline**

any pipeline connecting to the subsea tree assembly outboard the flowline connector or hub

**3.1.22****flowline connector support frame**

structural frame which receives and supports the flowline connector and transfers flowline loads back into the wellhead or seabed anchored structure

**3.1.23****flowline connector system**

equipment used to attach subsea pipelines and/or control umbilicals to a subsea tree

EXAMPLE Tree-mounted connection systems used to connect a subsea flowline directly to a subsea tree, connect a flowline end termination to the subsea tree through a jumper, connect a subsea tree to a manifold through a jumper, etc.

**3.1.24****flow loop**

piping that connects the outlet(s) of the subsea tree to the subsea flowline connection and/or to other tree piping connections (crossover piping, etc.)

**3.1.25****guide funnel**

tapered enlargement at the end of a guidance member to provide primary guidance over another guidance member

**3.1.26****guideline**

taut line from the seafloor to the surface for the purpose of guiding equipment to the seafloor structure

**3.1.27****high-pressure riser**

tubular member which extends the wellbore from the mudline wellhead or tubing head to a surface BOP

**3.1.28****horizontal tree**

tree that does not have a production master valve in the vertical bore but in the horizontal outlets to the side

**3.1.29****hydraulic rated working pressure**

maximum internal pressure that the hydraulic equipment is designed to contain and/or control

NOTE Hydraulic pressure should not be confused with hydraulic test pressure.

**3.1.30****hydrostatic pressure**

maximum external pressure of ambient ocean environment (maximum water depth) that equipment is designed to contain and/or control

**3.1.31****intervention fixture**

device or feature permanently fitted to subsea well equipment to facilitate subsea intervention tasks including, but not limited to,

- grasping intervention fixtures;
- docking intervention fixtures;
- landing intervention fixtures;
- linear actuator intervention fixtures;
- rotary actuator intervention fixtures;
- fluid coupling intervention fixtures

**3.1.32**

**intervention system**

means to deploy or convey intervention tools to subsea well equipment to carry out intervention tasks, including

- ROV;
- ROT;
- ADS;
- Diver

**3.1.33**

**intervention tool**

device or ROT deployed by an intervention system to mate or interface with an intervention fixture

**3.1.34**

**lifting pad eye**

pad eye, intended for lifting and suspending a designed load or packaged assembly

**3.1.35**

**lower workover riser package**

**LWRP**

unitized assembly that interfaces with the tree upper connection and allows sealing of the tree vertical bore(s)

**3.1.36**

**mudline suspension system**

drilling system consisting of a series of housings used to support casing strings at the mudline, installed from a bottom-supported rig using a surface BOP

**3.1.37**

**orienting bushings**

non-pressure-containing parts that are used to orient equipment or tools with respect to the wellhead

**3.1.38**

**outboard tree piping**

subsea tree piping that is downstream of the last tree valve (including choke assemblies) and upstream of flowline connection

See **flow loop** (3.1.24).

**3.1.39**

**permanent guidebase**

structure that sets alignment and orientation relative to the wellhead system and provides entry guidance for running equipment on or into the wellhead assembly

**3.1.40**

**pressure-containing part**

part whose failure to function as intended results in a release of wellbore fluid to the environment

EXAMPLES Bodies, bonnets, stems.

**3.1.41**

**pressure-controlling part**

part intended to control or regulate the movement of pressurized fluids

EXAMPLE Valve-bore sealing mechanisms, choke trim and hangers.

**3.1.42****rated working pressure****RWP**

maximum internal pressure that equipment is designed to contain and/or control

NOTE Rated working pressure should not be confused with test pressure.

**3.1.43****re-entry spool**

tree upper connection profile, which allows remote connection of a tree running tool, LWRP or tree cap

**3.1.44****reverse differential pressure**

condition during which differential pressure is applied to a choke valve in a direction opposite to the specified operating direction

NOTE This can be in the operating or closed-choke position.

**3.1.45****running tool**

tool used to run, retrieve, position or connect subsea equipment remotely from the surface

EXAMPLES Tree running tools, tree cap running tools, flowline connector running tools, etc.

**3.1.46****subsea BOP**

blowout preventer designed for use on subsea wellheads, tubing heads or trees

**3.1.47****subsea casing hanger**

device that supports a casing string in the wellhead at the mudline

**3.1.48****subsea completion equipment**

specialized tree and wellhead equipment used to complete a well below the surface of a body of water

**3.1.49****subsea wellhead housing**

pressure-containing housing that provides a means for suspending and sealing the well casing strings

**3.1.50****subsea wireline/coiled tubing BOP**

subsea BOP that attaches to the top of a subsea tree to facilitate wireline or coiled tubing intervention

**3.1.51****surface BOP**

blowout preventer designed for use on a surface facility such as a fixed platform, jackup or floating drilling on intervention unit

**3.1.52****swivel flange**

flange assembly consisting of a central hub and a separate flange rim that is free to rotate about the hub

NOTE Type 17SV swivel flanges can mate with standard ISO type 17SS and 6BX flanges of the same size and pressure rating.

**3.1.53****tieback adapter**

device used to provide the interface between mudline suspension equipment and subsea completion equipment

**3.1.54**

**tree cap**

pressure-containing environmental barrier installed above production swab valve in a vertical tree or tubing hanger in a horizontal tree

**3.1.55**

**tree connector**

mechanism to join and seal a subsea tree to a subsea wellhead or tubing head

**3.1.56**

**tree guide frame**

structural framework that may be used for guidance, orientation and protection of the subsea tree on the subsea wellhead/tubing head, and that also provides support for tree flowlines and connection equipment, control pods, anodes and counterbalance weights

**3.1.57**

**tree-side outlet**

point where a bore exits at the side of the tree block

**3.1.58**

**umbilical**

hose, tubing, piping, and/or electrical conductor that directs fluids and/or electrical current or signals to or from subsea trees

**3.1.59**

**upstream**

direction of movement towards the reservoir

**3.1.60**

**valve block**

integral block containing two or more valves

**3.1.61**

**vertical tree**

tree with the master valve in the vertical bore of the tree below the side outlet

**3.1.62**

**wear bushing**

bore protector that also protects the casing hanger below it

**3.1.63**

**wellhead housing pressure boundary**

wellhead housing from the top of the wellhead to where the lowermost seal assembly seals

**3.1.64**

**wye spool**

spool between the master and swab valves of a TFL tree, that allows the passage of TFL tools from the flowlines into the bores of the tree

**3.2 Abbreviated terms and symbols**

ADS	atmospheric diving system
AMV	annulus master valve
ANSI	American National Standards Institute
API	American Petroleum Institute



ASME	American Society of Mechanical Engineers
ASV	annulus swab valve
AWS	American Welding Society
AWV	annulus wing valve
BOP	blowout preventer
CGB	completion guidebase
CID	chemical injection – downhole
CIT	chemical injection – tree
CRA	corrosion-resistant alloy
CRM	corrosion-resistant material
EDP	emergency disconnect package (see ISO 13628-7)
FAT	factory acceptance test
FEA	finite element analysis
GRA	guidelineless re-entry assembly
HXT	horizontal subsea tree
ID	inside diameter
LRP	lower riser package (see ISO 13628-7)
LWRP	lower workover riser package (LRP + EDP) (see ISO 13628-7)
NACE	National Association of Corrosion Engineers
NDE	non-destructive examination
OD	outside diameter
OEC	other end connectors
PGB	permanent guidebase
PMR	per manufacturer's rating
PMV	production master valve
PR2	performance requirement level two
PSL	product specification level
PSV	production swab valve
PWV	production wing valve
QTC	qualification test coupon
RMS	root mean square
ROT	remotely operated tool (see ISO 13628-9)
ROV	remotely operated vehicle (see ISO 13628-8)
RWP	rated working pressure
$S_b$	bending stress

$S_m$	membrane stress
$S_Y$	yield strength
SCSSV	surface-controlled subsurface safety valve
SCF	stress concentration factor
SIT	system integration test
SWL	safe working load
TFL	through-flowline (see ISO 13628-3)
TGB	temporary guidebase
USV	underwater safety valve (see ISO 10423)
VXT	vertical subsea tree
WCT-BOP	wireline/coil tubing blowout preventer (see ISO 13628-7)
XOV	cross-over valve
XT	subsea tree

## 4 Service conditions and production specification levels

### 4.1 Service conditions

#### 4.1.1 General

Service conditions refer to classifications for pressure, temperature and the various wellbore constituents and operating conditions for which the equipment is designed.

#### 4.1.2 Pressure ratings

Pressure ratings indicate rated working pressures, expressed as megapascals (MPa), with equivalent pounds per square inch (psi) in parentheses. It should be noted that pressure is gauge pressure.

#### 4.1.3 Temperature classifications

Temperature classifications indicate temperature ranges, from minimum (ambient or flowing) to maximum flowing fluid temperatures, expressed in degrees Celsius ( $^{\circ}\text{C}$ ), with equivalent degrees Fahrenheit ( $^{\circ}\text{F}$ ) given in parentheses. Classifications are listed in ISO 10423.

#### 4.1.4 Sour service designation and marking

For material classes DD, EE, FF and HH, the manufacturer shall meet the requirements of ISO 15156 (all parts) for material processing and material properties (e.g. hardness). Choosing material class and specific materials for specific conditions is ultimately the responsibility of the purchaser.

Material classes DD, EE, FF, HH shall include as part of the designation and marking the maximum allowable partial pressure of  $\text{H}_2\text{S}$ , expressed in pounds per square inch absolute. The maximum allowable partial pressure shall be as defined by ISO 15156 (all parts) at the designated API temperature class for the limiting component(s) in the equipment assembly.

EXAMPLE "FF-1,5" indicates material class FF rated at 1,5 psia  $\text{H}_2\text{S}$  maximum allowable partial pressure.

Where no  $\text{H}_2\text{S}$  limit is defined by ISO 15156 (all parts) for the partial pressure, "NL" shall be used for marking (e.g., "DD-NL").

Users of this part of ISO 13628 should recognize that resistance to cracking caused by H<sub>2</sub>S is influenced by a number of other factors for which some limits are given in ISO 15156 (all parts). These include, but are not limited to,

- pH;
- temperature;
- chloride concentration;
- elemental sulfur.

NOTE For the purposes of the provisions in this subclause, ANSI/NACE MR0175/ISO 15156 is equivalent to ISO 15156 (all parts).

In making the material selections, the purchaser should also consider the various environmental factors and production variables listed in Annex A.

#### 4.1.5 Material classes

It is the responsibility of the end user to specify materials of construction for pressure-containing and pressure-controlling equipment. Material classes AA-HH as defined in Table 1 shall be used to indicate the material of those equipment components. Guidelines for choosing material class based on the retained fluid constituents and operating conditions are given in Annex M.

## 4.2 Product specification levels

Guidelines for selecting an appropriate product specification level (PSL) are provided in Annex M. The PSL of an assembled system of wellhead or tree equipment shall be determined by the lowest PSL of any pressure-containing or -controlling component in the assembly. Structural components and other non-pressure-containing/-controlling parts of equipment manufactured to this part of ISO 13628 are not defined by PSL requirements but by the manufacturer's specifications.

All pressure-containing components of equipment manufactured to this part of ISO 13628 shall comply with the requirements of PSL 2, PSL 3, or PSL 3G as established in ISO 10423. Pressure-controlling components shall comply with the requirements of PSL 2, PSL 3, or PSL 3G as specified in 5.4 and ISO 10423, except where additions or modifications are noted within this part of ISO 13628. These PSL designations define different levels of requirements for material qualification, testing, and documentation. PSL 3G does not necessarily imply that an assembly shall be gas-tested beyond the component/subassembly level (such as individual valves, chokes, tubing hangers, etc.). The purchaser shall specify whether it is required to gas-test an upper-level assembly manufactured to PSL 3G (such as a VXT or HXT assembly) as an integral unit at FAT.

## 5 Common system requirements

### 5.1 Design and performance requirements

#### 5.1.1 General

##### 5.1.1.1 Product capability

Product capability is defined by the manufacturer based on analysis and testing, more specifically:

- validation testing (see 5.1.7), which is intended to demonstrate and qualify performance of generic product families, as being representative of defined product variants;
- performance requirements, which define the operating capability of the specific "as-shipped" items (as specified in 5.1.1 and 5.1.2), which is demonstrated by reference to both factory acceptance testing and relevant validation testing data.

Performance requirements are specific and unique to the product in the “as-shipped” condition. All products shall be designed and qualified for their application in accordance with 5.1, 6.1, and Clauses 7 through 11.

**5.1.1.2 Pressure integrity**

Product designs shall be capable of withstanding rated working pressure at rated temperature without deformation to such an extent that prevents meeting any other performance requirement, providing that stress criteria are not exceeded.

**5.1.1.3 Thermal integrity**

Product designs shall be capable of functioning throughout the temperature range for which the product is rated. Components shall be rated and qualified for the maximum and minimum operating temperatures that they can experience in service, Joule-Thompson cooling effects, imposed flowline heating or heat-retention (insulation) effects. Thermal analysis can be used to establish component temperature-operating requirements. ISO 10423 provides information for design and rating of equipment for use at elevated temperatures.

**5.1.1.4 Materials**

Product shall be designed with an appropriate material class selected from Table 1, and shall conform to the requirements of ISO 10423.

**Table 1 — Material requirements**

Materials class <sup>a</sup>	Minimum material requirements	
	Body, bonnet and flange	Pressure-controlling parts, stems and mandrel hangers
AA-General service	Carbon or low alloy steel	Carbon or low alloy steel
BB-General service	Carbon or low alloy steel	Stainless steel
CC-General service	Stainless steel	Stainless steel
DD-Sour service <sup>a</sup>	Carbon or low alloy steel <sup>b</sup>	Carbon or low alloy steel <sup>b</sup>
EE-Sour service <sup>a</sup>	Carbon or low alloy steel <sup>b</sup>	Stainless steel <sup>b</sup>
FF-Sour service <sup>a</sup>	Stainless steel <sup>b</sup>	Stainless steel <sup>b</sup>
HH-Sour service <sup>a</sup>	CRAs <sup>b,c,d</sup>	CRAs <sup>b,c,d</sup>

NOTE Refer to 5.1.2.3 for information regarding material class selection.

<sup>a</sup> As defined in ISO 10423; in accordance with ISO 15156 (all parts).

<sup>b</sup> In accordance with ISO 15156 (all parts).

<sup>c</sup> CRA required on retained fluid wetted surfaces only; CRA cladding of low-alloy or stainless steel is permitted.

<sup>d</sup> CRA as defined in 3.1.13. The definition of CRA in ISO 15156 (all parts) does not apply.

NOTE For the purposes of the provisions in this table, ANSI/NACE MR0175/ISO 15156 is equivalent to ISO 15156 (all parts).

**5.1.1.5 Load capability**

Product designs shall be capable of sustaining rated loads without deformation to such an extent that prevents meeting any other performance requirement, providing stress criteria are not exceeded. Product designs that support tubulars shall be capable of supporting the rated load without collapsing the tubulars below the drift diameter.

Design requirements and criteria found in this part of ISO 13628 are based on rated working pressure and external loads relevant for installation, testing and normal operations. Additional design requirements due to drilling-riser- or workover-riser-imparted loads should be considered by the manufacturer, and overall operating limits documented. ISO 13628-7 specifies design requirements for the workover riser and includes additional operational conditions, such as extreme and accidental events (vessel drive-off, drift-off or motion-compensator lock-up). These load conditions shall be considered for qualifying the equipment; see 5.1.7. The purchaser should confirm that anticipated operating loads are within the operating limits of the equipment being used for the specific application.

#### 5.1.1.6 Cycles

Product designs shall be capable of performing and operating in service as intended for the number of operating cycles as specified by the manufacturer. Products should be designed to operate for the required pressure/temperature cycles, cyclic external loads and multiple make/break (latch/unlatch), as applicable and where applicable as verified in validation testing.

#### 5.1.1.7 Operating force or torque

Products shall be designed to operate within the manufacturer's force or torque specification, as applicable and where applicable as verified in validation testing.

#### 5.1.1.8 Stored energy

The design shall consider the release of stored energy and ensure that this energy can safely be released prior to the disconnection of fittings, assemblies, etc. Notable examples of this include, but are not limited to, trapped pressure and compressed springs.

### 5.1.2 Service conditions

#### 5.1.2.1 Pressure ratings

##### 5.1.2.1.1 General

Pressure ratings shall comply with 5.1.2.1.2 to 5.1.2.1.8. Where small-diameter lines, such as SCSSV control lines or chemical injection lines, pass through a cavity, such as the tree/tubing-hanger cavity, equipment bounding that cavity shall be designed for the maximum pressure in any of the lines, unless a means is provided to monitor and relieve the cavity pressure in the event of a leak in any of those lines; see 7.9.1 and 9.2.7 for additional information. In addition, the effects of external loads (i.e. bending moments, tension), ambient hydrostatic loads and fatigue shall be considered. For the purpose of this part of ISO 13628, pressure ratings shall be interpreted as rated working pressure (3.1.41).

Seal designs should consider conditions where deep water can result in reverse pressure acting on the seal due to external hydrostatic pressure exceeding internal bore pressure. All operating conditions (i.e. commissioning, testing, start-up, operation, blowdown) should be considered.

##### 5.1.2.1.2 Subsea trees

##### 5.1.2.1.2.1 Standard pressure rating

Whenever feasible, assembled equipment that contains and controls well pressure, such as valves, chokes, wellhead housings and connectors, shall be specified by the purchaser, and designed and manufactured to one of the following standard rated working pressures: 34,5 MPa (5 000 psi), 69 MPa (10 000 psi) or 103,5 MPa (15 000 psi). Standard pressure ratings facilitate safety and interchangeability of equipment, particularly where end connections are in accordance with this part of ISO 13628 or other industry standard, such as ISO 10423. Intermediate pressure ratings, e.g. 49,5 MPa (7 500 psi), for pressure-controlling and pressure-containing parts are not considered except for tubing-hanger conduits and/or tree penetrations and

connections leading to upstream components in the well (such as SCSSVs, chemical-injection porting, sensors), which may have a higher-than-working-pressure design requirement.

**5.1.2.1.2.2 Non-standard working pressure rating**

Non-standard pressure ratings are outside the scope of this part of ISO 13628.

**5.1.2.1.3 Tubing hangers**

The standard RWPs for subsea tubing hangers shall be 34,5 MPa (5 000 psi), 69 MPa (10 000 psi) and 103,5 MPa (15 000 psi). The production or annulus tubing connection may have a pressure rating lower than the tubing hangers RWP. Also, the tubing hanger may contain flow passages that shall not exceed 1,0 times the RWP of the tubing hanger assembly plus 17,2 MPa (2 500 psi).

**5.1.2.1.4 Subsea wellhead equipment**

The standard RWPs for subsea wellheads shall be 34,5 MPa (5 000 psi), 69 MPa (10 000 psi) and 103,5 MPa (15 000 psi). Tools and internal components, such as casing hangers, may have other pressure ratings, depending on size, connection thread and operating requirements.

**5.1.2.1.5 Mudline equipment**

Standard rated working pressures do not apply to mudline casing hanger and tieback equipment. Instead, each equipment piece shall be rated for working pressure in accordance with the methods given in Clause 10 and Annex E.

**5.1.2.1.6 Hydraulically controlled components**

All hydraulically operated components and hydraulic control lines that are not exposed to wellbore fluids shall have a hydraulic RWP (design pressure) in accordance with the manufacturer's written specification. All components that use the hydraulic system to operate should be designed to perform their intended function at 0,9 times hydraulic RWP or less, and shall be able to withstand occasional pressure anomalies to 1,1 times hydraulic RWP.

**5.1.2.1.7 Thread limitations**

Equipment designed for a mechanical connection with small-bore connections [up to 25,4 mm (1,00 in) bore], test ports and gauge connections shall be internally threaded, shall conform to the limits on use specified in 7.3 and shall conform to the size and RWP limitations given in Table 2. OECs, with internal threads and meeting the requirements of 7.3 that are designed specifically for small-bore, test-port or gauge-connection applications, may also be used.

**Table 2 — Pressure ratings for internal thread connections**

Type of thread	Size mm (in)	Rated working pressure MPa (psi)
API line pipe (sizes)	12,7 (1/2)	69,0 (10 000)
High-pressure connections	Types I, II and III in accordance with ISO 10423	103,5 (15 000)

**5.1.2.1.8 Other equipment**

The design of other equipment, such as running, retrieval and test tools, shall comply with the purchaser's/manufacture's specifications.

### 5.1.2.2 Temperature ratings

#### 5.1.2.2.1 Standard operating temperature rating

Equipment covered by this part of ISO 13628 shall be designed and rated to operate throughout a temperature range defined by the manufacturer and as a system in accordance with ISO 10423. The minimum temperature rating for valve and choke actuators shall be 2 °C (35 °F) to 66 °C (151 °F). The minimum classification for the subsea system in accordance with ISO 13268-4 shall be temperature classification V [2 °C (35 °F) to 121 °C (250 °F)]. When impact toughness is required of materials (PSL 3 and PSL 3G), the minimum classification for pressure-containing and pressure-controlling materials should be temperature classification U [– 18 °C (0 °F) to 121 °C (250 °F)].

Pre-deployment testing at the surface may be conducted at environmental temperatures lower than the system rating as specified by the manufacturer. It is not necessary that the product qualification be performed at the pre-deployment testing temperature.

Consideration should be given to equipment operation due to transitional low-temperature effects on choke bodies and associated downstream components when subject to Joule-Thompson (J-T) cooling effects due to extreme gas-pressure differentials.

Transitional low-temperature effects associated with J-T cooling and well start-up conditions may be addressed by one or more of the following methods:

- a) component validation to the required minimum temperature as specified in 5.1.7;
- b) component validation to the standard operating temperature range combined with material Charpy V-notch qualification at or below the minimum transitional operating temperature in accordance with 4.1.3;
- c) component validation to the standard operating temperature range combined with additional material documentation supporting suitability for operation at the transitional temperature range.

#### 5.1.2.2.2 Standard operating temperature rating adjusted for seawater cooling

If the manufacturer shows, through analysis or testing, that certain equipment on subsea wellhead, mudline suspension, and tree assemblies, such as valve and choke actuators, will not exceed 66 °C (150 °F) when operated subsea with a retained fluid at least 121 °C (250 °F), then this equipment may be designed and rated to operate throughout a temperature range of 2 °C (35 °F) to 66 °C (150 °F).

Conversely, subsea components and equipment that are thermally shielded from sea water by insulating materials shall demonstrate that they can work within temperature range of the designated temperature classification.

#### 5.1.2.2.3 Temperature design considerations

The design should take into account the effects of temperature gradients and cycles on the metallic and non-metallic parts of the equipment.

#### 5.1.2.2.4 Storage/test temperature considerations

If subsea equipment will be stored or tested on the surface at temperatures outside of its temperature rating, then the manufacturer should be contacted to determine if special storage or surface-testing procedures are recommended. Manufacturers shall document any such special storage or surface-testing considerations.

### 5.1.2.3 Material class ratings

#### 5.1.2.3.1 General

Equipment shall be constructed with materials (metallics and non-metallics) suitable for its respective material classification in accordance with Table 1. Table 1 does not define all factors within the wellhead environment, but provides material classes for various levels of service conditions and relative corrosivity.

#### 5.1.2.3.2 Material classes

Material selection is the ultimate responsibility of the user as he has the knowledge of the production environment as well as control over the injected treatment chemicals. The user may specify the service conditions and injection chemicals, asking the supplier to recommend materials for his review and approval.

Material requirements shall comply with Table 1. All pressure-containing components shall be treated as "bodies" for determining material trim requirements from Table 1. However, in this part of ISO 13628, other wellbore-pressure boundary-penetration equipment, such as grease and bleeder fittings, shall be treated as "stems" as set forth in Table 1. Metal seals shall be treated as pressure-controlling parts with regards to Table 1.

All pressure-containing components exposed to well-bore fluids shall be in accordance with ISO 15156 (all parts) and Table 1 material classes AA-HH.

### 5.1.3 Design methods and criteria

#### 5.1.3.1 General

Structural strength and fatigue strength shall be evaluated in this part of ISO 13628. ASME *BPVC*, Section VIII, Division 2, Appendix 5, or other recognized standards may be used when calculating fatigue. Localized bearing-stress values are beyond the scope of this part of ISO 13628. The effects of external loads (i.e. bending moment, tensions, etc.) on the assembly or components are not explicitly addressed in this part of ISO 13628 or in ISO 10423. As equipment covered by this part of ISO 13628 are exposed to external loads, ISO 13628-7 may be used to define the structural strength design.

The purchaser shall confirm that anticipated operating loads are within the operating limits of the equipment being used for the specific application.

#### 5.1.3.2 Standard ISO flanges, hubs and threaded equipment

Flanges and hubs for subsea use shall be designed in accordance with 7.1, 7.2 and/or 7.3.

#### 5.1.3.3 Pressure-controlling components

Casing hangers, tubing hangers and all pressure-controlling components, except for mudline suspension wellhead equipment, shall be designed in accordance with ISO 10423.

Pressure-controlling components of mudline suspension equipment shall be designed in accordance with Clause 10.

#### 5.1.3.4 Pressure-containing components

Wellheads, bodies, bonnets, stems and other pressure-containing components shall be designed in accordance with ISO 10423.



### 5.1.3.5 Closure bolting and critical bolting

Closure bolting (pressure-containing) and critical bolting (high-load bearing) require a preload to a high percent of material yield strength as noted below.

Closure bolting of all 6BX and 17SS flanges shall be made up using a method that has been shown to result in a stress range between 67 % and 73 % of the bolt's material yield stress.

This stress range should result in a preload in excess of the separation force at test pressure while avoiding excessive stress beyond 83 % of the bolt material's yield strength.

Closure bolting manufactured from carbon or alloy steel, when used in submerged service, shall be limited to 321 HBN (Rockwell "C" 35) maximum due to concerns with hydrogen embrittlement when connected to cathodic protection. Closure bolting for material classes AA-HH that is covered by insulation shall be treated as exposed bolting in accordance with ISO 15156 (all parts).

The maximum allowable tensile stress for closure bolting shall be determined considering initial bolt-up, rated working pressure and hydrostatic test pressure conditions. Bolting stresses, based on the root area of the thread, shall not exceed the limits given in ISO 10423.

### 5.1.3.6 Primary structural components

Primary structural components, such as guidebases, shall be designed in accordance with accepted industry practices and documented in accordance with 5.1.5. A safety/design factor of 1,5 or more based on the minimum material yield strength shall be used in the design calculations; other recognized industry codes may be used. It should be noted that many codes already include safety factors. Alternatively, an FEA may be used to demonstrate that applied loads do not result in deformation to such an extent that prevents meeting any other performance requirement. As an alternative, a design validation load test of 1,5 times its rated capacity may be substituted for design analysis. The component shall sustain the test loading without deformation to such an extent that any other performance requirement is affected and the test documents shall be retained.

For other load conditions, the design (safety) factors given in ISO 13628-7 apply.

### 5.1.3.7 Specific equipment

Refer to ISO 10423. In addition, refer to Clauses 6 through 11 for additional design requirements. If specific design requirements in Clauses 6 through 11 differ from the general requirements in Clause 5, then the equipment's specific design requirements shall take precedence.

### 5.1.3.8 Design of equipment for lifting

#### 5.1.3.8.1 General

Lifting devices are divided into two categories for design and testing: permanently installed lifting equipment and reusable lifting equipment. Testing of reusable lifting equipment is more stringent as this equipment is subject to lifting cycles throughout its lifetime. Annex K provides design, testing, and maintenance guidelines for both reusable lifting equipment and permanently installed equipment.

Equipment used exclusively for running in, on or out of the wellbore should be designed as given in 5.1.3.6 or 5.1.3.7, Annex H or Annex K, as applicable.

#### 5.1.3.8.2 Pad eyes

Pad eyes should be designed as given in Annex K. Load capacities of pad eyes shall be marked as specified in 5.5.2.

### 5.1.3.8.3 Primary members

Primary members are structural members that are in the direct load path of lifting loads. If the primary member is either pressure-containing or pressure-controlling, and is designed to be pressurized during lifting operations, then the load capacity shall include the additional stresses induced by internal rated working pressure.

### 5.1.3.8.4 Load testing

Load testing of lifting pad eyes should be done in accordance with Annex K.

## 5.1.4 Miscellaneous design information

### 5.1.4.1 Fraction to decimal equivalence

ISO 10423, Annex B, gives the equivalent fraction and decimal values.

### 5.1.4.2 Tolerances

Unless otherwise specified in tables or figures of this part of ISO 13628, the following tolerances shall apply.

- a) The tolerance for dimensions with format  $X$  is  $\pm 0,5$  mm ( $X,X$  is  $\pm 0,02$  in).
- b) The tolerance for dimensions with format  $X,X$  is  $\pm 0,5$  mm ( $X,XX$  is  $\pm 0,02$  in).
- c) The tolerance for dimensions with format  $X,XX$  is  $\pm 0,13$  mm ( $X,XXX$  is  $\pm 0,005$  in).
- d) Dimensions listed as  $\frac{XXXX}{YYYY}$  are considered the maximum dimension ( $XXXX$ ) and the minimum dimension ( $YYYY$ ), overriding the nominal tolerances to accommodate certain geometries.

Dimensions less than 10 mm (0,39 in) should be listed with two digit accuracy so that the imperial equivalent is within the same two-digit manufacturing tolerance.

### 5.1.4.3 End and outlet bolting

#### 5.1.4.3.1 Hole alignment

End and outlet bolt holes for ISO flanges shall be equally spaced and shall straddle the common centre line; see Table 7.

#### 5.1.4.3.2 Stud-thread engagement

Stud-thread engagement length into the body of ISO studded flanges shall be a minimum of one times the OD of the stud.

### 5.1.4.4 Other bolting

The stud-thread anchoring means shall be designed to sustain a tensile load equivalent to the load that can be transferred to the stud through a fully engaged nut.

#### 5.1.4.5 Test, vent, injection and gauge connections

##### 5.1.4.5.1 Sealing

All test, vent, injection and gauge connections shall provide a leak-tight seal at the test pressure of the equipment in which they are installed.

A means shall be provided such that any pressure behind a test, vent, injection or gauge connector can be safely vented prior to removal of the component.

##### 5.1.4.5.2 Test and gauge connection ports

Test and gauge connection ports shall comply with the requirements of 5.1.2.1.7 and 7.3.

#### 5.1.4.6 External corrosion-control programme

External corrosion control for subsea trees and wellheads shall be provided by appropriate materials selection, coating systems and cathodic protection. A corrosion-control programme is an ongoing activity that consists of testing, monitoring and replacement of spent equipment. The implementation of a corrosion-control programme is beyond the scope of this part of ISO 13628.

#### 5.1.4.7 Coatings (external)

##### 5.1.4.7.1 Methods

The coating system and procedure used shall comply with the written specification of the equipment manufacturer or the coating manufacturer as agreed between the user/purchaser and manufacturer. In the event neither has a specification, Annex I may be used.

##### 5.1.4.7.2 Record retention

The manufacturer shall maintain, and have available for review, documentation specifying the coating systems and procedures used.

##### 5.1.4.7.3 Colour selection

Colour selection for underwater visibility shall be in accordance with ISO 13628-1.

#### 5.1.4.8 Cathodic protection

**5.1.4.8.1** Cathodic protection system design requires the consideration of the external area of the equipment being protected. It is the responsibility of the equipment manufacturer to document and maintain the information on the area exposed to replenished seawater of all equipment supplied in accordance with 5.1.5. This documentation shall contain the following information as a minimum:

- location and size of wetted surface area for specific materials, coated and uncoated;
- areas where welding is allowed or prohibited;
- materials of construction and coating systems applied to external wetted surfaces;
- control line interface locations;
- flowline interfaces.

**5.1.4.8.2** The following cathodic protection design codes shall apply:

- NACE SP0176;
- DNV RP B401.

**5.1.4.8.3** Some materials have demonstrated a susceptibility to hydrogen embrittlement when exposed to cathodic protection in seawater. Care should be exercised in the selection of materials for applications requiring high strength, corrosion resistance and resistance to hydrogen embrittlement. Materials that have shown this susceptibility include martensitic stainless steels and the more highly alloyed steels having yield strengths over 900 MPa (131 000 psi). Other materials subject to this phenomenon are hardened, low-alloy steels, particularly with hardness levels greater than Rockwell "C" 35 [with yield strength exceeding 900 MPa (131 000 psi)], precipitation-hardened nickel-copper alloys and some high-strength titanium alloys.

### 5.1.5 Design documentation

Documentation of designs shall include methods, assumptions, calculations, qualification test reports and design-validation requirements. Design documentation requirements shall include, but not be limited to, those criteria for size, test and operating pressures, material, environmental requirements and other pertinent requirements on which the design is being based. Design documentation media shall be clear, legible, reproducible and retrievable. Design documentation retention shall be for a minimum of five years after the last unit of that model, size and rated working pressure is manufactured. All design requirements shall be recorded in a manufacturer's specification, which shall reflect the requirements of this part of ISO 13628, the purchaser's specification or manufacturer's own requirements. The manufacturer's specification may consist of text, drawings, computer files, etc.

### 5.1.6 Design review

Design documentation shall be reviewed and verified by any qualified individual other than the individual who created the original design.

### 5.1.7 Validation testing

#### 5.1.7.1 Introduction

The minimum validation test procedures that shall be used to qualify product designs in accordance with Table 3 are defined in 3.5.1.7. The manufacturer shall define additional validation tests that are applicable and demonstrate that this validation testing can be correlated with the intended service life and/or operating conditions in accordance with the purchaser requirements.

#### 5.1.7.2 General

Prototype equipment (or first article) and fixtures used to qualify designs using these validation procedures shall be representative of production models in terms of design, production dimensions/tolerances, intended manufacturing processes, deflections and materials. If a product design undergoes any changes in fit-form-function or material, the manufacturer shall document the impact of such changes on the performance of the product. A design that undergoes a substantive change becomes a new design requiring retesting. A substantive change is a change that affects the performance of the product in the intended service condition. A substantive change is considered as any change from the previously qualified configuration or material selection that can affect performance of the product or intended service. This shall be recorded and the manufacturer shall justify whether or not re-qualification is required. This may include changes in fit-form-function or material. A change in material might not require retesting if the suitability of the new material can be substantiated by other means.

**NOTE** Fit, when defined as the geometric relationship between parts, includes the tolerance criteria used during the design of a part and mating parts. Fit, when defined as a state of being adjusted to, or shaped for, includes the tolerance criteria used during the design of a seal and its mating parts.

For items with primary and secondary independent seal mechanisms, the seal mechanisms shall be independently verified. Equipment should be qualified with the minimal lubricants required for assembly unless the lubricants can be replenished when the equipment is in service or is provided for service in a sealed chamber.

The actual dimensions of equipment subjected to validation test shall be within the allowable range for dimensions specified for normal production equipment. Worst-case conditions for dimensional tolerances should be addressed by the manufacturer, giving consideration to concerns such as sealing and mechanical functioning.

#### 5.1.7.3 Test media

Gas shall be used as the test medium for pressure-hold periods for pressure-containing and -controlling equipment. Other equipment may be hydrostatically tested.

Manufacturers may, at their option, substitute a gas test for some or all of the required validation pressure tests. Validation test procedures and acceptance criteria shall meet the requirements in 5.4.

#### 5.1.7.4 Pressure-cycling tests

Table 3 lists equipment that shall be subjected to repetitive hydrostatic (or gas, if applicable) pressure-cycling tests simulating start-up and shutdown pressure cycling that occurs in long-term field service. For these hydrostatic cycling tests, the equipment shall be alternately pressurized to the full rated working pressure and then fully depressurized until the specified number of pressure cycles has been completed. No holding period is required for each pressure cycle. A standard hydrostatic (or gas, if applicable) test (see 5.4) shall be performed before and after the hydrostatic pressure cycling test.

#### 5.1.7.5 Load testing

The manufacturer's rated load capacities for equipment in accordance with this part of ISO 13628 shall be verified by both validation testing and engineering analysis. The equipment shall be loaded to the rated capacity to the number of cycles in accordance with Table 3 during the test without deformation to such an extent that any other performance requirement is affected (unless otherwise specified). Engineering analysis shall be conducted using techniques and programmes that comply with documented industry practice.

See 5.1.3.3 for load-testing of pressure-controlling components, and 5.1.3.6 for load-testing of primary structural components.

#### 5.1.7.6 Temperature cycling tests

Validation tests shall be performed at a test temperature at or beyond the range of the rated operating temperature classification while at RWP or load condition.

Table 3 lists equipment that shall be subjected to repetitive temperature cycling tests simulating start-up and shutdown temperature cycling that occur in long-term field service. For these temperature cycling tests, the equipment shall be alternately heated and cooled to the upper and lower temperature extremes of its rated operating temperature classification as defined in 5.1.2.2. During temperature cycling, rated working pressure shall be applied to the equipment at the temperature extremes with no leaks beyond the acceptance criteria established in ISO 10423. As an alternative to testing, manufacturer shall provide other objective evidence, consistent with documented industry practice, that the equipment will meet performance requirements at both temperature extremes.

#### 5.1.7.7 Life-cycle/endurance testing

Life-cycle/endurance testing, such as make-break tests on connectors and operational testing of valves, chokes, and actuators, is intended to evaluate long-term wear characteristics of the equipment being tested. Such tests may be conducted at a temperature specified by the manufacturer and documented as appropriate for that product and rating. Table 3 lists equipment that shall be subjected to extended life-cycle/endurance testing to simulate long-term field service. For these life-cycle/endurance tests, the equipment shall be subjected to operational cycles in accordance with the manufacturer's performance specifications (i.e. make-up to full torque/break-out, open/close under full rated working pressure). Connectors, including stabs, shall be subjected to a full disconnect/lift as part of the cycle. Additional specifications for life-cycle/endurance testing of the components listed in Table 3 can be found in the equipment-specific clauses covering these items (Clauses 6 to 11). Secondary functions, such as connector secondary unlock, shall be

included in this testing. Where it can be demonstrated that pressure and/or temperature testing similarly loads the component or assembly to that condition specified for endurance-cycle testing, those cycles can be accumulated toward the total number of cycles specified for endurance-cycle testing. For example, the 200/3 pressure/temperature cycles used to test a valve can cumulatively qualify as 203 cycles toward the 600 total cycles required for endurance cycling.

**Table 3 — Minimum validation test requirements**

Component	Pressure/load cycling test	Temperature cycling test <sup>a</sup>	Endurance cycling test (total cumulative cycles)
Metal seal exposed to well bore in production	200	3	PMR <sup>c</sup>
Metal seal not exposed to well bore in production	3	3	PMR <sup>c</sup>
Non-metallic seal exposed to well bore in production	200	3	PMR <sup>c</sup>
Non-metallic seal not exposed to well bore in production	3	3	PMR <sup>c</sup>
OEC	200	NA	PMR <sup>c</sup>
Wellhead/tree/tubing head connectors	3	NA	PMR <sup>c</sup>
Workover/intervention connectors	3	NA	100
Tubing heads	3	NA	NA
Valves <sup>b</sup>	200	3	600
Valve actuators	200	3	600
Tree cap connectors	3	NA	PMR <sup>c</sup>
Flowline connectors	200	NA	PMR <sup>c</sup>
Subsea chokes	200	3	500
Subsea choke actuators	200	3	1 000 <sup>e</sup>
Subsea wellhead casing hangers	3	NA	NA
Subsea wellhead annulus seal assemblies (including emergency seal assemblies)	3	3	NA
Subsea tubing hangers, HXT internal tree caps and crown plugs	3	NA	NA
Poppets, sliding sleeves, and check valves	200	3	PMR <sup>c</sup>
Mudline tubing heads	3	NA	NA
Mudline wellhead, casing hangers, tubing hangers	3	NA	NA
Running tools <sup>d</sup>	3	NA	PMR <sup>c</sup>

NOTE Pressure cycles, temperature cycles and endurance cycles are run as specified above in a cumulative test with one product without changing seals or components.

<sup>a</sup> Temperature cycles shall be in accordance with ISO 10423.

<sup>b</sup> Before and after the pressure cycle test a low-pressure, 2 MPa (300 psi) ± 10 %, leak-tightness test shall be performed.

<sup>c</sup> PMR signifies “per manufacturer rating”.

<sup>d</sup> Subsea wellhead running tools are not included.

<sup>e</sup> A choke-actuator cycle is defined as total choke stroke from full-open to full-close or full-close to full-open.

#### 5.1.7.8 Product family validation

A product of one size may be used to verify other sizes in a product family, providing the following requirements are met.

- a) A product family is a group of products for which the design principles, physical configuration, and functional operation are the same, but which differ in size.
- b) The product geometries shall be parametrically modelled such that the design stress levels and deflections in relation to material mechanical properties are based on the same criteria for all members of the product family in order to verify designs via this method.
- c) Scaling may be used to verify the members of a product family in accordance with ISO 10423, Annex F.

#### 5.1.7.9 Documentation

The manufacturer shall document the procedures used and the results of all validation tests used to qualify equipment in this part of ISO 13628. The documentation requirements for validation testing shall be the same as the documentation requirements for design documentation in 5.1.5 with the addition that the documentation shall identify the person(s) conducting and witnessing the tests and the time and place of the testing.

### 5.2 Materials

#### 5.2.1 General

The material performance, processing and compositional requirements for all pressure-containing and pressure-controlling parts specified in this part of ISO 13628 shall conform to ISO 10423. For purposes of this reference, subsea wellheads and tubing heads shall be considered as bodies.

#### 5.2.2 Material properties

In addition to the materials specified in ISO 10423, other, higher-strength materials may be used provided they satisfy the design requirements of 5.1 and comply with the manufacturer's written specifications. The Charpy impact values required by ISO 10423 are minimum requirements and higher values may be specified to meet local legislation or user requirements.

For forged material used for pressure-containing and high-load-bearing parts, forging practices, heat treatment and test coupon (QTC or prolongation) requirements should meet those of API RP 6HT. In addition, the test coupon shall accompany the material it qualifies through all thermal processing, excluding stress relief.

"High-load-bearing" describes a load condition acting on a component such that the resulting loaded equivalent stress exceeds 50 % of the base-material's minimum yield strength.

#### 5.2.3 Product specification level

The pressure-containing and pressure-controlling materials used in equipment covered by this part of ISO 13628 shall comply with requirements for PSL 2 or PSL 3/3G in accordance with ISO 10423. All other items should be in accordance with the manufacturer's written specification.

#### 5.2.4 Corrosion considerations

##### 5.2.4.1 Corrosion from retained fluids

Material selection based upon wellbore fluids shall be made in accordance with 5.1.2.3.

#### 5.2.4.2 Corrosion from marine environment

Corrosion protection through material selection based on a marine environment shall consider, as a minimum, the following:

- external fluids;
- internal fluids;
- weldability;
- crevice corrosion;
- dissimilar-metals effects;
- cathodic-protection effects;
- coatings.

#### 5.2.5 Structural materials

Structural components are normally of welded construction using common structural steels. Any strength grade that conforms to the requirements of the design may be used.

### 5.3 Welding

#### 5.3.1 Pressure-containing/controlling components

All welding on pressure-containing/controlling components shall comply with the requirements of ISO 10423 for PSL 2 or PSL 3/3G, as specified.

#### 5.3.2 Structural components

Structural welds shall be treated as non-pressure-containing welds and shall comply with ISO 10423 or a documented structural welding code, such as AWS D1.1. Weld locations where the loaded stress exceeds 50 % of the weld or base-material yield strength, and welded pad eyes for lifting shall be identified as “critical welds” and shall be treated as in 5.3.1, PSL 3/3G.

#### 5.3.3 Corrosion-resistant overlays

##### 5.3.3.1 General

Corrosion resistant overlays shall be made in accordance with ISO 10423 requirements with regard to the following:

- a) welding requirements for weld overlay for corrosion-resistance and/or hard facing and other material surface-property controls,
- b) quality requirements for welding, in accordance with 5.3.3.2 to 5.3.3.5.

##### 5.3.3.2 Ring grooves

Overlay of ring grooves shall meet the applicable requirements of ISO 10423 with regard to the following:

- a) weld overlay requirements in ISO 10423 for corrosion-resistant ring grooves;
- b) quality requirements in ISO 10423 for weld-metal overlay (ring grooves, stems, valve bore sealing mechanisms and choke trim).

NOTE Overlay of ring grooves is typically intended to provide corrosion-resistance only.



### 5.3.3.3 Stems, valve bore sealing mechanisms and choke trim

Overlay of stems, valve bore sealing mechanisms (VBSM), and choke trim shall meet the applicable requirements of ISO 10423 with regard to the following:

- a) weld overlay requirements in ISO 10423 for other corrosion-resistant overlays;
- b) quality requirements in ISO 10423 for weld-metal overlay (ring grooves, stems, valve-bore sealing mechanisms and choke trim).

NOTE Overlay of stems, valve bore sealing mechanisms and choke trim is typically intended to provide both corrosion resistance and wear resistance.

### 5.3.3.4 CRM overlay of wetted surfaces, pressure-containing parts

Overlay of wetted surfaces on pressure-containing parts shall meet applicable requirements of ISO 10423 with regard to the following:

- a) weld overlay requirements in ISO 10423 for other corrosion-resistant overlays;
- b) quality requirements in ISO 10423 for weld-metal corrosion-resistant alloy overlay (bodies, bonnets, end and outlet connections).

NOTE CRM overlay of wetted surfaces on pressure-containing parts is typically intended to meet the requirements of ISO 10423 material class HH, and/or high resistance to seawater and retained fluids. This category does not include localized CRM overlay of seal surfaces only.

### 5.3.3.5 Other corrosion-resistant overlay of seal surfaces

Overlay of seal surfaces on pressure-containing and pressure-controlling parts shall meet applicable requirements of ISO 10423 with regard to the following:

- a) weld overlay requirements in ISO 10423 for other corrosion-resistant overlays;
- b) quality requirements, which shall be specified by the manufacturer and shall meet, as a minimum, requirements in ISO 10423 for weld-metal overlay (ring grooves, stems, valve-bore sealing mechanisms and choke trim).

NOTE Localized CRM overlay of seal surfaces on pressure-containing or pressure-controlling parts is typically intended to provide enhanced corrosion resistance for critical seal interfaces. This is distinct from full CRM overlay of wetted surfaces to meet material class requirements.

Requirements established by the manufacturer shall include consideration of design requirements for the overlay.

## 5.4 Quality control

### 5.4.1 General

The quality-control requirements for equipment specified in this part of ISO 13628 shall conform to ISO 10423.

For those components not covered in ISO 10423, equipment-specific quality-control requirements shall comply with the manufacturer's written specifications. Purchaser and manufacturer should agree on any additional requirements.

### 5.4.2 Product specification level

Quality control and testing for pressure-containing and pressure-controlling components covered by this part of ISO 13628 shall comply with requirements for PSL 2 or PSL 3 as established in ISO 10423. Quality control

for PSL 3G shall be the same as for PSL 3 with the exception of pressure testing, which shall comply with 5.4.6. Requirements for other components shall be in accordance with the manufacturer's written specification.

### 5.4.3 Structural components

Quality control and testing of welding for structural components shall be specified as non-pressure-containing welds and comply with ISO 10423 or a documented structural welding code, such as AWS D.1.1. "Critical welds" shall be treated as pressure-controlling welds and comply with ISO 10423, PSL 3, excluding volumetric NDE examination.

### 5.4.4 Lifting devices

Guidelines for lifting pad eyes are defined in Annex K.

Additionally, welds on pad eyes and other lifting devices attached by welding shall be in accordance with the weld requirements as specified in 5.3.2 and 5.4.3. All pad eye and lifting device welds shall be designated as "critical welds". Lifting pad eyes shall also be individually proof-load tested to at least two and one-half (2,5) times the documented safe working load for the individual pad eye (SWL/number of pad eyes). Pad eyes shall be tested with magnetic particles and/or dye penetrant following proof testing. Proof-load testing shall be repeated following significant repairs or modifications prior to being put into use. The base metal and welds of pad eyes and other lifting devices shall meet PSL 3 requirements.

### 5.4.5 Testing for PSL 2 and PSL 3 equipment

#### 5.4.5.1 Hydrostatic pressure testing

Procedures for hydrostatic pressure testing of equipment specified in Clauses 6 through 11 shall conform to the requirements for PSL 2 or PSL 3 in accordance with ISO 10423, with the exception that parts may be painted prior to testing.

For all pressure ratings, the hydrostatic body test pressure shall be a minimum of 1,5 times the rated working pressure. The acceptance criterion for hydrostatic pressure tests shall be no visible leakage during the hold period. If a pressure-monitoring gauge and/or a chart recorder is used for documentation purposes, the chart record should have an acceptable pressure settling rate not exceeding 3 % of the test pressure per hour. The final settling pressure shall not fall below the test pressure before the end of the test hold period. Initial test pressure shall not be greater than 5 % above the specified test pressure.

#### 5.4.5.2 Drift test

Drift testing should be conducted in accordance with ISO 10423 after completion of pressure testing. Vertical runs that require the passage of wellbore tools shall be physically drifted with the ISO 10423-specified drift mandrel. Runs that require the passage of TFL tools shall be physically drifted with the ISO 13628-3 drift mandrels. Other configurations that do not allow the use of a physical drift mandrel due to access or length of run may be confirmed as to drift alignment by other means, such as the use of a borescope and visual inspection.

### 5.4.6 Testing for PSL 3G equipment

#### 5.4.6.1 Drift test

See 5.4.5.2.

#### 5.4.6.2 Pressure testing

##### 5.4.6.2.1 Hydrostatic body and seat test for valves and chokes

A hydrostatic body test and hydrostatic valve seat tests shall be performed prior to any gas testing.

The acceptance criterion for hydrostatic pressure tests shall be no visible leakage during the hold period. If a pressure-monitoring gauge and/or a chart recorder is used for documentation purposes, the chart record should have an acceptable pressure settling rate not exceeding 3 % of the test pressure per hour. The final settling pressure shall not fall below the test pressure before the end of the test hold period. Initial test pressure shall not be greater than 5 % above the specified test pressure.

#### 5.4.6.2.2 Gas body test for assembled valves and chokes

The test shall be conducted under the following conditions.

- a) The test shall be conducted at ambient temperature.
- b) The test medium shall be nitrogen.
- c) The test shall be conducted with the equipment completely submerged in a water bath.
- d) The valves and chokes shall be in the partially open position during testing.
- e) The gas body test for assembled equipment shall consist of a single holding period of not less than 15 min, the timing of which shall not start until the test pressure has been reached and the equipment and pressure-monitoring gauge have been isolated from the pressure source.
- f) The test pressure shall equal the rated working pressure of the equipment.

The acceptance criterion for gas tests shall be no visible bubbles during the hold period. If a pressure-monitoring gauge and/or chart recorder is used for documentation purposes, the chart record should have a pressure settling rate not exceeding 3 % of the test pressure per 15 min or per 2 MPa (300 psi), whichever is less. The final settling pressure shall not fall below the test pressure before the end of the test hold period. Initial test pressure shall not be greater than 5 % above the specified test pressure.

#### 5.4.6.2.3 Gas seat test — Valves

The gas seat test may be conducted in addition to, or in place of, the hydrostatic seat test.

The test shall be conducted under the following conditions.

- a) The gas pressure shall be applied to each side of gate or plug of bi-directional valves with the other side open to the atmosphere. Unidirectional valves shall be tested in the direction indicated on the body, except for check valves, which shall be tested from the downstream side.
- b) The test shall be conducted at ambient temperatures.
- c) The test medium shall be nitrogen.
- d) The test shall be conducted with the equipment completely submerged in a bath of water.
- e) Testing shall consist of two, monitored holding periods.
- f) The primary test pressure shall equal rated working pressure.
- g) The primary test monitored hold period shall be 15 min.
- h) The pressure shall be reduced to zero between the primary and secondary hold points, but not by opening the valve.
- i) The secondary test pressure shall be 2 MPa  $\pm$  0,2 MPa (300 psi  $\pm$  30 psi).
- j) The secondary test monitored hold period shall be 15 min; the upstream pressure is then vented to zero, but not by opening the valve.

- k) The valves shall be fully opened and fully closed between tests.
- l) Bi-directional valves shall be tested on the other side of the gate or plug using the same procedure.

The acceptance criterion for gas tests shall be no visible bubbles during the hold period.

For the primary high-pressure seat test, if a pressure-monitoring gauge and/or chart recorder is used for documentation purposes, the chart record should have a pressure settling rate not exceeding 3 % of the test pressure per 15 min or per 2 MPa (300 psi), whichever is less. The final settling pressure shall not fall below the test pressure before the end of the test hold period. Initial test pressure shall not be greater than 5 % above the specified test pressure.

For the secondary low pressure seat test, the test pressure shall be 2 MPa  $\pm$  0,2 MPa (300 psi  $\pm$  30 psi) over the hold period.

#### 5.4.7 Hydraulic system pressure testing

Components that contain a hydraulic control fluid shall be tested to a hydrostatic body/shell test at 1,5 times the hydraulic RWP of their respective hydraulic systems with primary and secondary hold times in accordance with 5.4, PSL 3. All operating subsystems (actuators, connectors, etc.) that are operated by the hydraulic system shall function at 0,9 times the hydraulic RWP or less of their respective system.

As the hydraulic system does not communicate with the wellbore, its RWP shall be limited to the weakest pressure-containing element or less, as specified by the manufacturer. The hydrostatic test pressure of the hydraulic system shall be 1,5 times the hydraulic RWP with primary and secondary hold times in accordance with 5.4, PSL 3. The test medium is the hydraulic system fluid. Acceptance criterion is no visible leakage. Chart recording is not required.

#### 5.4.8 Cathodic protection

Electric continuity tests shall be performed to prove the effectiveness of the cathodic protection system. If the electrical continuity is not obtained, earth cabling shall be incorporated in the ineffective areas where the resistance is greater than 0,10  $\Omega$ .

### 5.5 Equipment marking

#### 5.5.1 General

Equipment that meets the requirements of this International Standard shall be marked "ISO 13628-4" in accordance with ISO 10423, marking "ISO 13628-4" in place of "ISO 10423."

All equipment marked "ISO 13628-4" shall, also, be marked with the following minimum information: part number, manufacturer name or trademark. See ISO 10423 for metallic marking locations.

Equipment shall be marked in either metric units or imperial units where size information is applicable and useful. The units shall be marked together with the numbers.

#### 5.5.2 Pad eyes and lift points

Pad eyes intended for lifting an assembly should be painted red and properly marked for lifting so as to alert personnel that safe handling can be made from this point.

Lift pad eyes or lift points on each respective assembly shall be marked with the documented total safe working load (SWL) as follows.

EXAMPLE 1 Using a four-pad eye lift arrangement, each with a static safe working load of 25 tons, yields a total safe working load (SWL) of 100 tons with a sling load lift-angle limit ( $90^\circ - \alpha$ ) of  $60^\circ$  from horizontal. The static marking at or near the lift location is as follows:

"100 tons total SWL static, 4 point lift, 60-90"

EXAMPLE 2 For offshore or immersion (subsea) lift conditions, the marking for the total dynamic safe working load should be marked in addition to the static load marking. The reduced SWL capacity reflects load amplification factors (LAF) that are listed in Annex K.

"50 tons total SWL dynamic, 4 point lift, 60-90"

**SAFETY PRECAUTIONS — Pad eyes on frames not painted red and/or properly labeled should be considered only as aids for handling lines (tag lines) or tie-down (transportation, sea fastening, etc.). Any pad eye or lift point not properly marked with the appropriate lift marking should not be used for lifting. Lifting from unmarked pad eyes can lead to serious damage or injury.**

Personnel should pay special attention to payload weights and their markings and, in particular its spelling, to make sure total safe working loads match rigging requirements: "tons" refers to an imperial ton (2 240 lbs); "s ton" refers to a "short ton" (2 000 lbs); "tonne" refers to a metric ton (1 000 kg or 2 200 lb).

All assemblies and equipment that are handled between supply boat and rig may have dedicated lifting equipment (sling assemblies, etc.), which comply with local legislation or regulations. All packages exceeding 100 kN (22 500 lbs) shall have pad eyes for handling and sea fastening. These pad eyes shall not be painted red and should be considered only as aids for handling lines (tag lines) or tie-down (transportation, sea fastening, etc.). Any pad eye not stamped or stenciled with the appropriate lift marking should not be used for lifting. Lifting from unmarked pad eyes can lead to serious damage or injury. All other equipment not suitable for shipping in baskets or containers shall be furnished with facilities for sea fastening as appropriate.

### 5.5.3 Other lifting devices

The rated lifting capacity of other lifting devices, such as tools, as determined in 5.1.3.8, shall be clearly marked in accordance with 5.5.2 in a position visible when the lifting device is in the operating position.

### 5.5.4 Temperature classification

Subsea equipment manufactured in accordance with 5.1.2.2 shall be marked with the appropriate temperature classification in accordance with ISO 10423.

## 5.6 Storing and shipping

### 5.6.1 Draining after testing

All equipment shall be drained and lubricated in accordance with the manufacturer's written specification after testing and prior to storage or shipment.

### 5.6.2 Rust prevention

Prior to shipment, parts and equipment shall have exposed metallic surfaces (except those otherwise designated, such as anodes or nameplates) either protected with a rust preventive coating that does not become fluid at temperatures less than 50 °C (125 °F) or filled with a compatible fluid containing suitable corrosion inhibitors in accordance with the manufacturer's written specification. Equipment already coated, but showing damage after testing, should undergo coating repair prior to storage or shipment as specified in 5.1.4.8.

### 5.6.3 Sealing surface protection

Exposed seals and seal surfaces, threads, and operating parts shall be protected from mechanical damage during shipping. Equipment or containers shall be designed such that equipment does not rest on any seal or seal surface during shipment or storage.

### 5.6.4 Loose seals and ring gaskets

Loose seals, stab subs and ring gaskets shall be individually boxed or wrapped for shipping and storage.

### 5.6.5 Elastomer age control

The manufacturer shall document instructions concerning the proper storage environment, age control procedures and protection of elastomer materials.

### 5.6.6 Hydraulic systems

Prior to shipment, the total shipment including hydraulic lines shall be flushed and filled in accordance with the manufacturer's written specification. Exposed hydraulic end fittings shall be capped or covered. All pressure shall be bled from equipment, unless otherwise agreed between the manufacturer and purchaser.

### 5.6.7 Electrical/electronic systems

The manufacturer shall document instructions concerning proper storage and shipping of all electrical cables, connectors and electronic packages (pods).

### 5.6.8 Shipments

For shipment, units and assemblies should be securely crated or mounted on skids so as to prevent damage and to facilitate sling handling. All metal surfaces shall be protected by paint or rust preventative, and all flange faces, clamp hubs and threads shall be protected by suitable covers.

Consideration should be given to transportation and handling onshore as well as offshore. Where appropriate, equipment should be supplied with removable bumper bars or transportation boxes/frames.

### 5.6.9 Assembly, installation and maintenance instructions

The manufacturer shall document instructions concerning field assembly, installation and maintenance of equipment. These shall address safe operating procedures and practices.

### 5.6.10 Extended storage

Storage and preservation requirements for equipment after delivery to the user is beyond the scope of this part of ISO 13628. The manufacturer shall provide recommendations for storage to the user upon request.

## 6 General design requirements for subsea trees and tubing hangers

### 6.1 General

#### 6.1.1 Introduction

Clause 6 provides specific requirements for the equipment covered in Clauses 7 and 9. Subsea tree assembly configurations vary depending on wellhead type, service, well shut-in pressure, water depth, reservoir parameters, environmental factors and operational requirements. As such, the subsea tree configuration requirements, including the location and quantity of USVs are not specified in Clause 6. As a minimum, the barrier philosophy in accordance with ISO 13628-1 shall be met. The number of potential leak paths should be minimized during system design.

Equipment that is used in the assembly of the subsea tree, but which is not covered in Clauses 6, 7, and 9, shall comply with the manufacturer's written specifications. Purchaser and manufacturer should agree on any additional requirements.

### 6.1.2 Handling and installation

Structural analysis should be performed by the user to ensure that structural failure does not occur at a point below the tree re-entry spool and that the tree can be left in a safe condition in the event of a drive-off before the tree running tool/EDP can be disconnected.

The design of the subsea tree assembly should consider the ease of handling and installation. All equipment assemblies should be balanced within 1°. Consideration should be given to the submerged condition of this equipment, including buoyancy or weighted modules removed after installation. The use of balance weights should be minimized to keep shipping weight to a minimum and the location of balance weights should be carefully chosen so that observation/access by diver/ROV is not compromised.

### 6.1.3 Orientation and alignment

The design should pay particular attention to the orientation and alignment between equipment packages. The manufacturer shall conduct tolerance and stack-up analysis to ensure that trees will engage tubing hangers, wellheads and guidebases; that tree running tools will engage re-entry spools; that caps will engage re-entry spools, etc. These studies shall take into account external influences, such as flowline forces, temperature, currents, riser offsets, etc. Equipment shall be suitably aligned and orientated before stab subs enter their sealing pockets. Where feasible during factory acceptance testing, calculations should be verified by realistic testing of interfaces that will be engaged remotely.

### 6.1.4 Rating

The PSL designation, pressure rating, temperature rating and material class assigned to the subsea tree assembly shall be determined by the minimum rating of any single component used in the assembly of the subsea tree that is normally exposed to wellbore fluid.

### 6.1.5 Interchangeability

Components and sub-assemblies for different arrangements of subsea tree configurations should be interchangeable if functional requirements permit.

**EXAMPLES** Change-out of tree connectors to suit different wellhead profiles, change-out of wing-valve arrangements for different services, such as production, injection, etc., and the interchangeability of spares.

Interchangeability between mating trees, tubing hangers, caps, tool interfaces, etc., shall be assured by the design and dimensional control. It is recommended that items that are engaged subsea be interfaced with a mating item or a fixture. Integration testing is outside the scope of this part of ISO 13628.

### 6.1.6 Safety

Testing is one of the most dangerous operations conducted on oilfield equipment. A pressure test intentionally exposes the equipment to a higher stored energy state than it sees in normal field operation to ensure that the design is sound, that materials have no significant flaws and that the equipment has been properly assembled. Normal personnel protective equipment does not provide protection in the event of a high-volume pressure release. The following are some recommended minimum practices to consider to improve personnel safety.

- Safe job analysis should be performed before any pressure and load testing is performed.
- When a component or assembly is pressure-tested, protective barriers should be utilized, personnel should be kept out of hazardous areas, and appropriate stand-off distances should be established. This is especially important the first time a new piece of equipment is tested.
- Venting of trapped air prior to hydrostatic testing is essential to minimize stored energy potential. The designer should take this into consideration when locating test/vent ports and when specifying the orientation of the equipment during test.

- Where practical, minimize the volume of stored pressure energy by applying higher pressure tests to smaller sub-assemblies versus testing full assemblies at one time. Or, make use of other energy-reduction methods such as volume-reducing devices in non-functional areas.
- Controlled methods should be specified for verifying and confirming that test pressures have been completely vented/bled down.

EXAMPLE Specifying multiple venting points, requiring all valves to be fully opened.

- Gas tests should always be performed only after hydrostatic testing and never at a pressure above the working pressure rating of the equipment.
- Gas tests should be performed only while equipment is submerged to the maximum water depth possible in the test pit/chamber.
- Consideration should be given to safe ways for test personnel to verify leakage, such as using remote pressure recorders, cameras, mirrors/periscopes, drip cloths/paper, etc., to look for drips/bubbles.
- The use of ballistics calculations have proven useful in establishing requirements for, and types of, shielding devices and safe work zones for test personnel.
- Pressure testing tools can fail just like the equipment being tested. Test equipment should be under a preventive maintenance program, since test flanges, clamps, hoses, etc., are exposed to more extreme pressure loads than any other equipment.
- As pressure-test hose lines always cross safety barriers, they should be secured/staked with a mechanical constraint to prevent whipping in the event that a hose or end fitting fails. Consider burying pressure lines to prevent damage in high-traffic areas from fork lifts, etc.

Safe access for personnel to equipment packages during testing, inspection, maintenance, preparation for installation or other tasks should be considered as part of the design. Where necessary, access devices should be furnished. Access devices should include a warning label stating that a fall-arrest device should be used where personnel are required to work on top of equipment packages. When assemblies are stacked, the access devices should be positioned to facilitate safe transfer from one assembly to the other.

## 6.2 Tree valving

### 6.2.1 Master valves, vertical tree

Any valve in the vertical bore of the tree between the wellhead and the tree side outlet shall be defined as a master valve. A vertical subsea tree shall have one or more master valves in the vertical production (injection) bore and vertical annulus (when applicable). At least one valve in each vertical bore shall be an actuated, fail-closed valve.

### 6.2.2 Master valves, horizontal tree

The inboard valve branching horizontally off the tree between the tree body and tubing hanger and the production (injection) flow path (bore) shall be defined as the production master valve. The inboard valve on the bore into the annulus below the tubing hanger shall be defined as the annulus master valve. A horizontal subsea tree shall have one or more master valves on each of the above bores. At least one valve in each of the above bores shall be an actuated, fail-closed valve.

### 6.2.3 Wing valves, vertical tree

A wing valve is a valve in the subsea tree assembly that controls either the production (injection) or annulus flow path and is not in the vertical bore of the tree. The side outlet for production (injection) shall have at least one wing valve. The annulus flow path of the subsea tree shall have at least one wing valve (depending on



tree configuration) when a second annulus master valve is not present, with respect to operational/process and/or well intervention requirements.

#### 6.2.4 Wing valves, horizontal tree

The horizontal subsea tree shall have a wing valve downstream (upstream – injection) of the master valve in both the production (injection) flow path and the annulus flow path with respect to operational/process and/or well intervention requirements.

#### 6.2.5 Swab closures, vertical and horizontal tree

Any bore that passes through the subsea tree assembly that can be used in workover operations shall be equipped with at least two swab closures. The swab closure is a device that allows vertical access into the tree but is not open during production flow. Swab closures may be caps, stabs, tubing plugs or valves. The removal or opening of the swab closure shall not result in any diametrical restriction through the production bore of the tree or tubing hanger.

Swab valves may be either manual or actuated. When actuated, they shall be operable only from the workover system.

Annulus access valves and/or workover valves are considered forms of swab closures.

#### 6.2.6 Crossover valves

A crossover valve is an optional valve that, when opened, allows communication between the annulus and production tree paths, which are normally isolated.

#### 6.2.7 Tree assembly pressure closures

This part of ISO 13628 is concerned only with the pressure-closure requirements contained within the subsea tree assembly. Other industry-recognized pressure closures contained in the total system, such as downhole SCSSVs or flowline valves, are beyond the scope of this part of ISO 13628. It is not intended that multiple pressure closure requirements of the subsea tree assembly replace the need for other system pressure closures.

#### 6.2.8 Production (injection) and annulus flow paths

The minimum requirement for valving in the production (injection) and annulus flowpaths to maintain the subsea tree as a barrier element, is one actuated, fail-closed master valve in the production (injection) bore and one actuated, fail-closed master valve in the annulus bore. Other valves as described in 6.2 may be added when required by legislation or project requirements with respect to operational/process and/or well-intervention requirements.

The annulus flow path shall be designed to allow for the management of casing pressure in the production annulus and the ability to circulate during workover and well-control situations with consideration given to reducing the risk of plugging.

A schematic for a typical vertical dual-bore subsea tree is illustrated in Figure 1. Figure 2 illustrates vertical trees with tubing heads. Figure 3 illustrates horizontal subsea trees.

#### 6.2.9 Production and annulus bore penetrations

There shall be at least two fail-closed pressure closures, one of which shall be an actuated, fail-closed valve, for any penetration leading into the path of the tree or tubing head. The master valve may be used as one of the barriers for conduit penetrations downstream of the master valve. There shall be at least one testable pressure closure between the wellhead and any penetration leading into the annulus path of the tree or tubing head.

Sealed sensor devices with two or more pressure-containing sealing barriers may be directly attached to the penetration without additional barrier devices, so long as the sensor device has at least the same design rating as tree or tubing head body it is connected to.

Flanges, clamp hubs or other end connection, as applicable, meeting the requirements of Clause 7 shall be used to provide connections for the penetrations to the tree or tubing head.

Figure 4 illustrate the minimum configurations that meet the requirements of 6.2.9.

NOTE The dotted inclusions are optional. A non-pressure-containing tree cap can be considered when two swab closures are included.

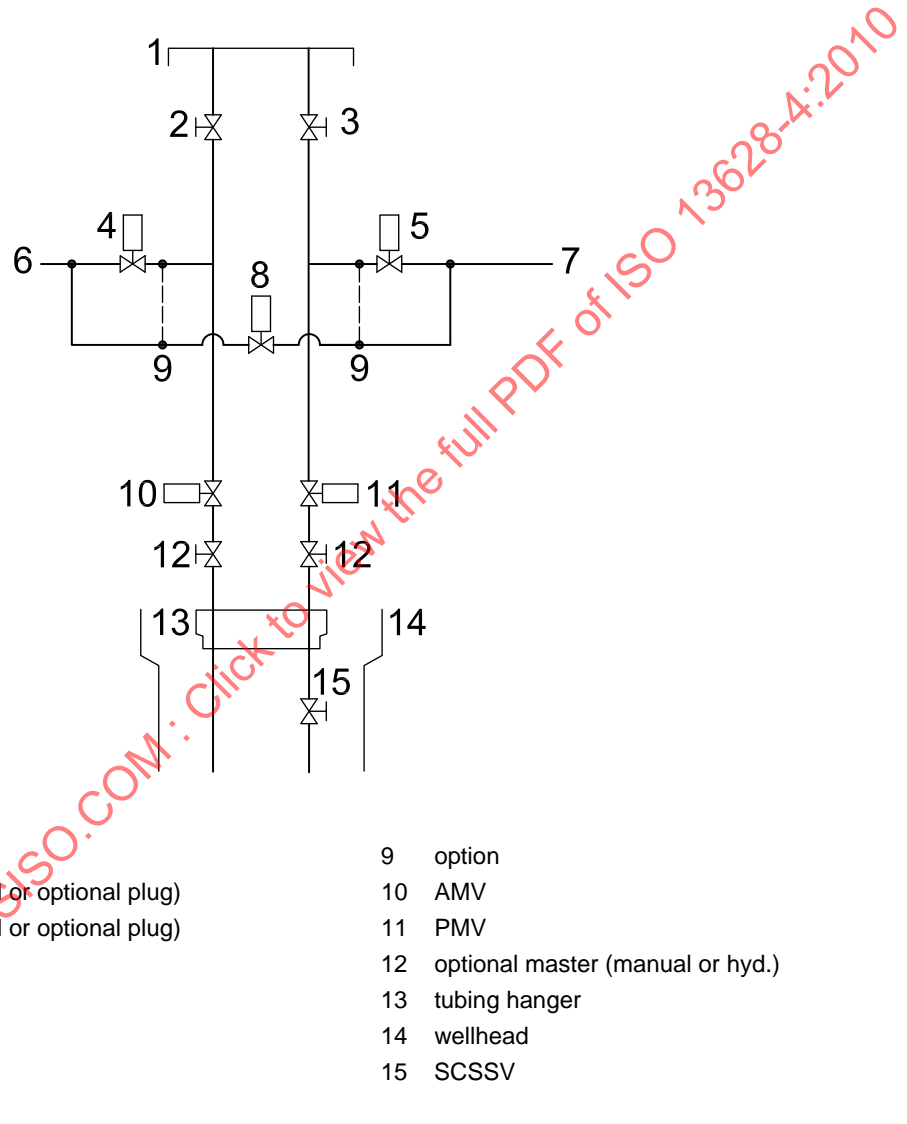

**Key**

- |  |                                     |
|--|-------------------------------------|
| 1 CAP  | 9 option                            |
| 2 ASV (manual or failed closed or optional plug) | 10 AMV                              |
| 3 PSV (manual or failed closed or optional plug) | 11 PMV                              |
| 4 AWV  | 12 optional master (manual or hyd.) |
| 5 PWV  | 13 tubing hanger                    |
| 6 annulus  | 14 wellhead                         |
| 7 production                                     | 15 SCSSV                            |
| 8 XOVS   |                                     |

**Figure 1 — Example of a dual-bore tree on a subsea wellhead**

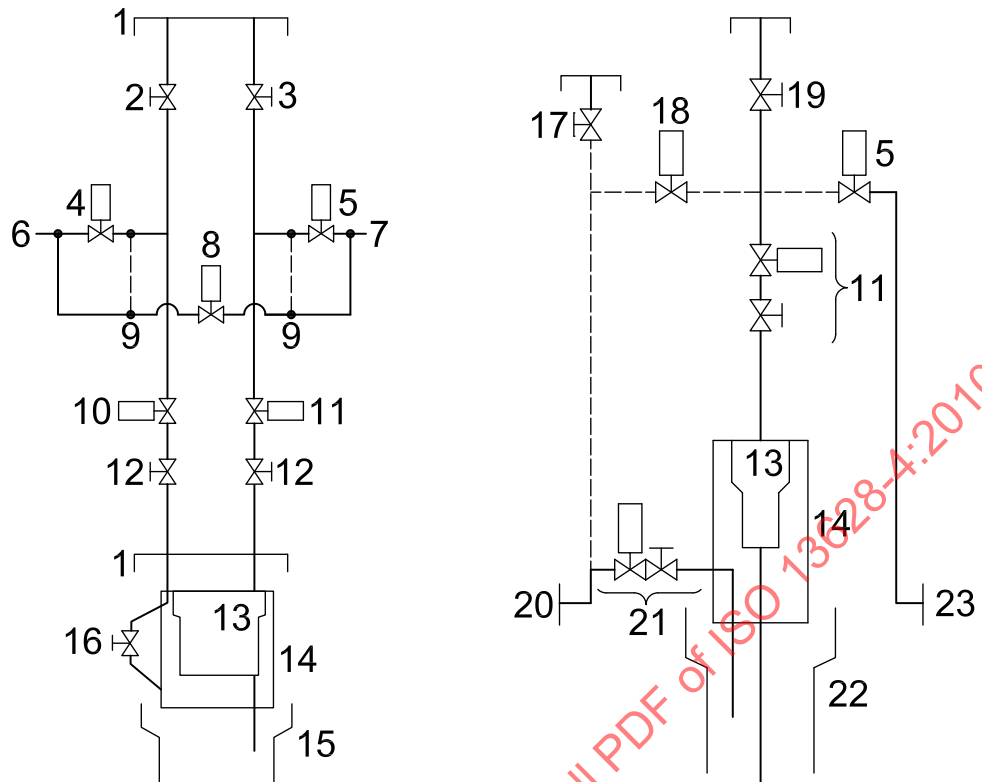

**Key**

- |  |   |
|--|---|
| 1 CAP  | 13 tubing hanger                              |
| 2 ASV (manual or failed closed or optional plug) | 14 tubing head                                |
| 3 PSV (manual or failed closed or optional plug) | 15 wellhead                                   |
| 4 AWV  | 16 annulus isolation                          |
| 5 PWV  | 17 optional ASV (WOV or AAV) (manual or hyd.) |
| 6 annulus  | 18 optional XOV                               |
| 7 production                                     | 19 PSV  |
| 8 XOV  | 20 to umbilical line or service line          |
| 9 option   | 21 annulus valves                             |
| 10 AMV   | 22 wellhead                                   |
| 11 PMV   | 23 production line                            |
| 12 optional master (manual or hyd.)              |   |

NOTE The dotted inclusions are optional. A non-pressure-containing tree cap can be considered when two swab closures are included.

**Figure 2 — Example of vertical trees on tubing heads**

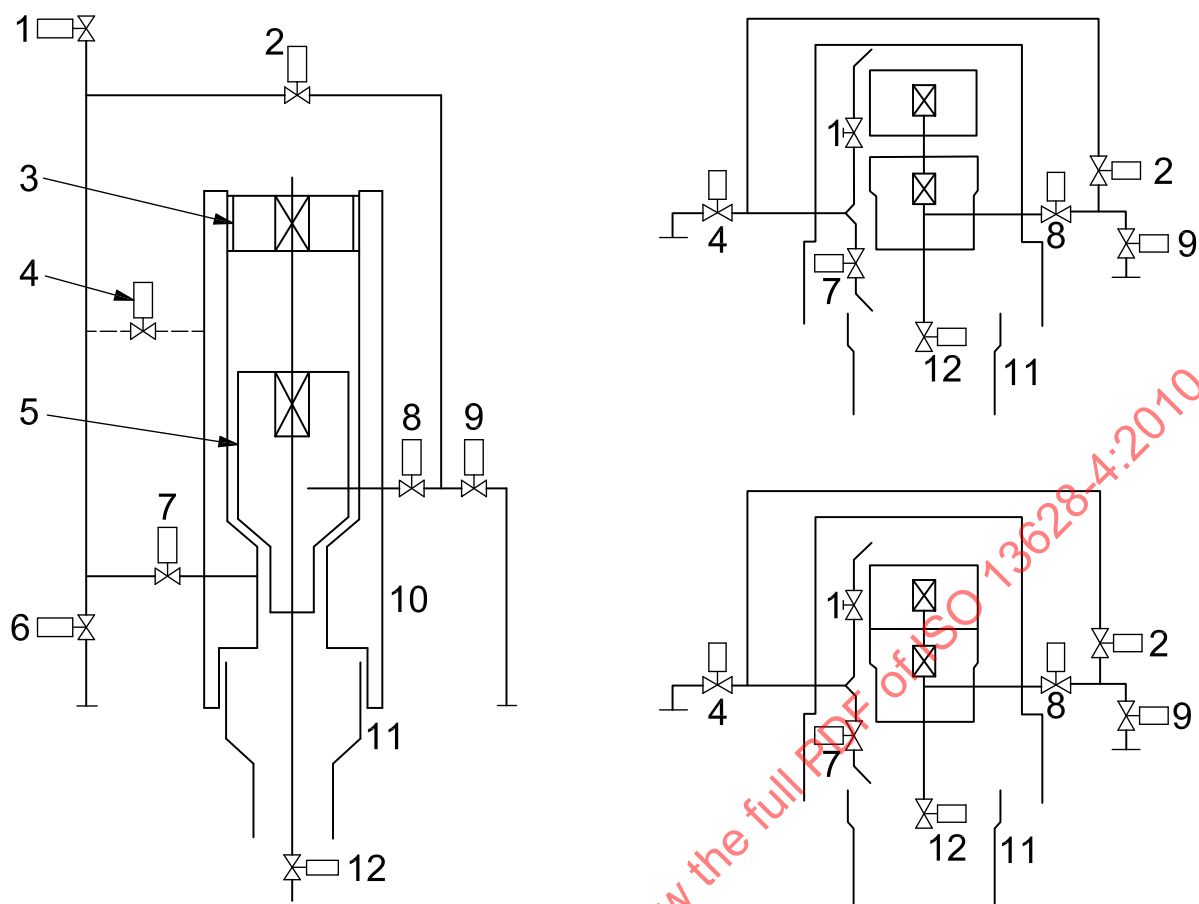

**Key**

- |                       |              |
|-----------------------|--------------|
| 1 ASV (WOV or AAV)    | 7 AMV        |
| 2 XOV                 | 8 PMV        |
| 3 tree cap            | 9 PWV        |
| 4 AWV                 | 10 tree body |
| 5 tubing hanger       | 11 wellhead  |
| 6 AWV (hyd or manual) | 12 SCSSV     |

**Figure 3 — Examples of horizontal trees**

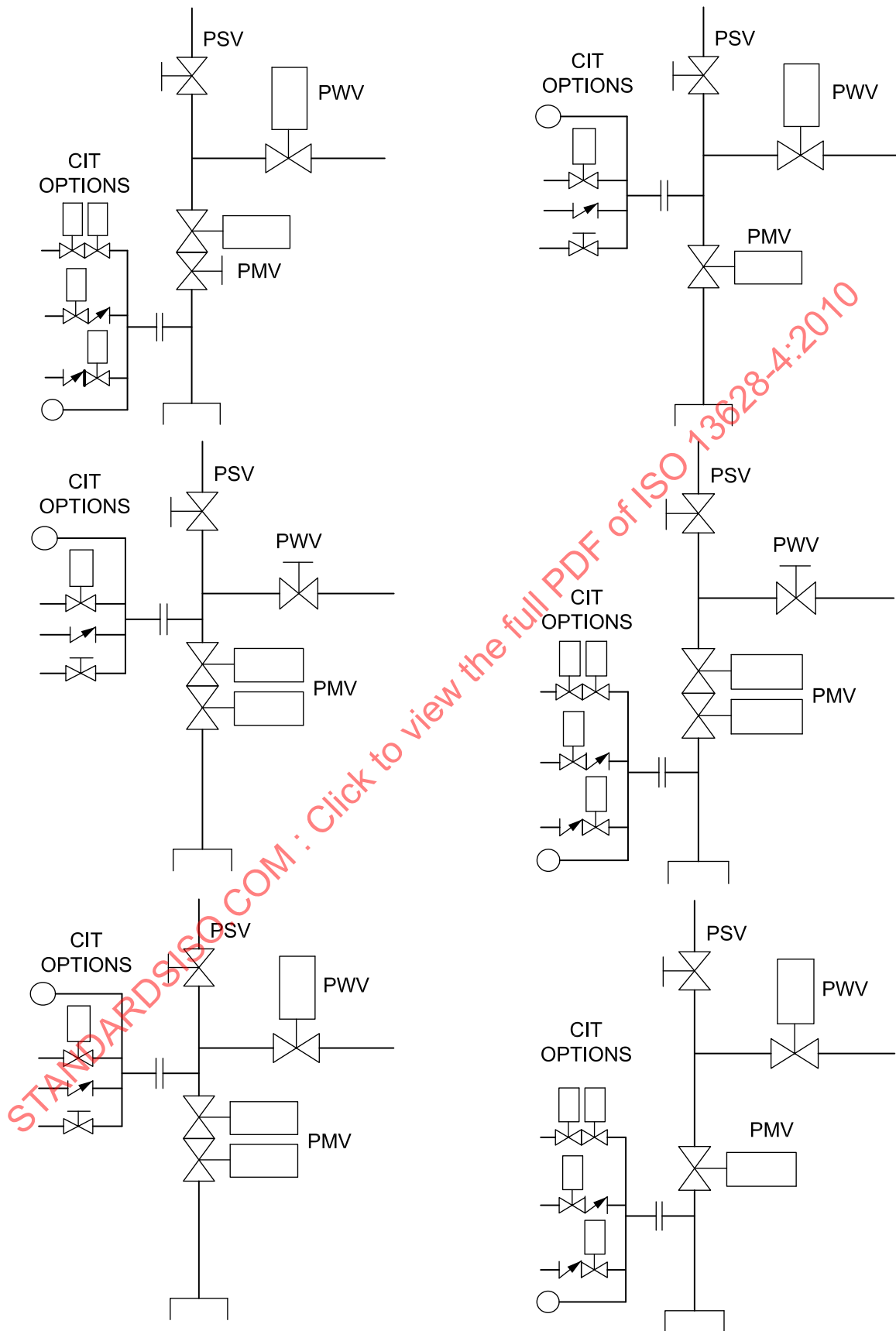

a) Production bore penetrations

Figure 4 — Examples of bore penetrations

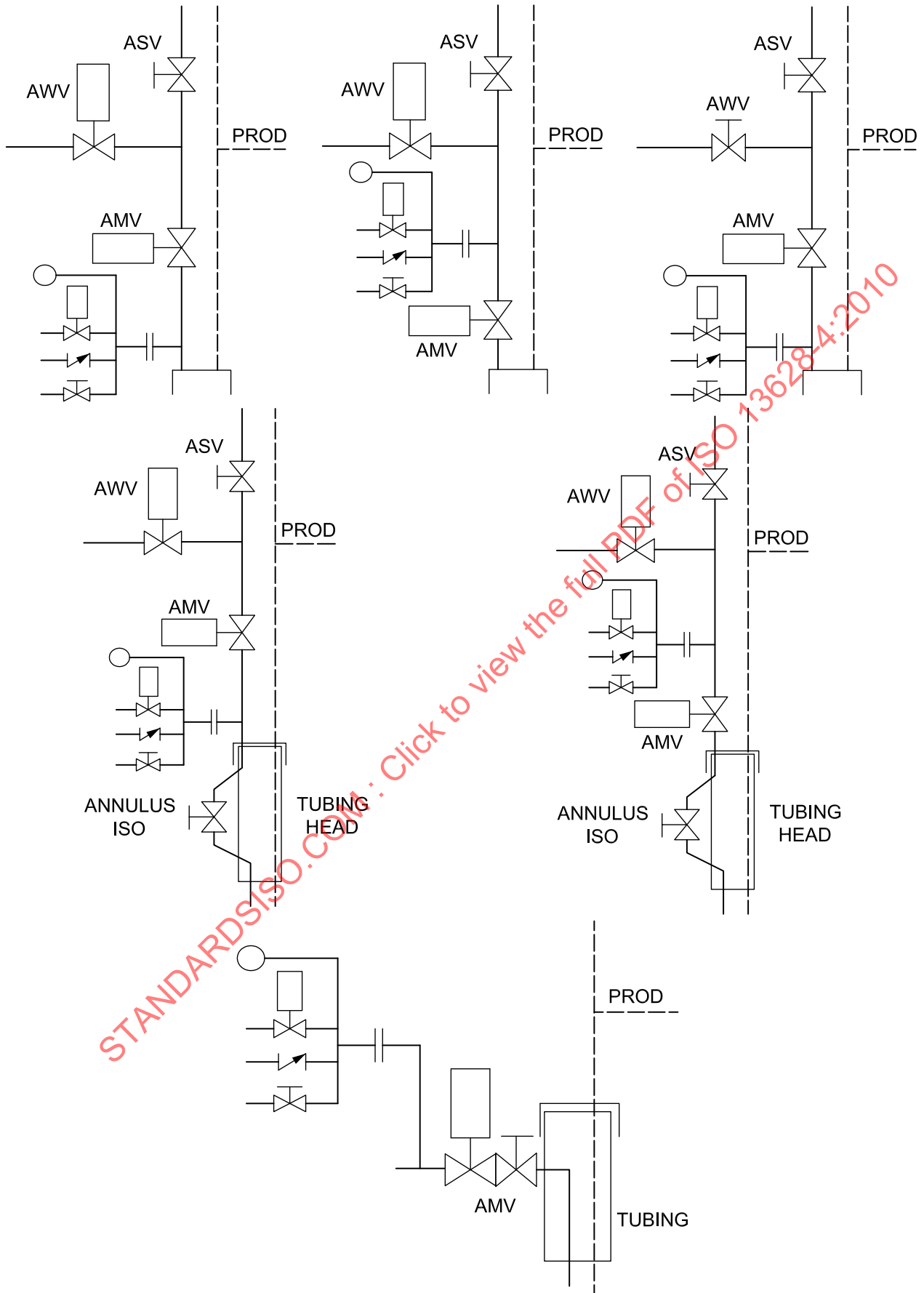

b) Annulus bore penetrations

### 6.2.10 SCSSV control line penetrations

At least one pressure-controlling closure shall be used at all SCSSV control-line penetrations that pass through either the tree or tubing head. Manual valves (diver/ROV-operated) are acceptable closing devices.

Any remotely operated closure device, including control-line couplers that are designed to prevent the ingress of seawater, used in the SCSSV control line circuit shall be designed such that it does not interfere with the closure of the SCSSV. Connections threaded directly into a tree body or wing-valve block for SCSSV control line penetrations are prohibited.

Check valves shall not be used anywhere in the SCSSV circuit if their closure can prevent venting down of the control pressure.

Figure 5 illustrates typical subsea tree valving for SCSSV circuits that meet the requirements of 6.2.

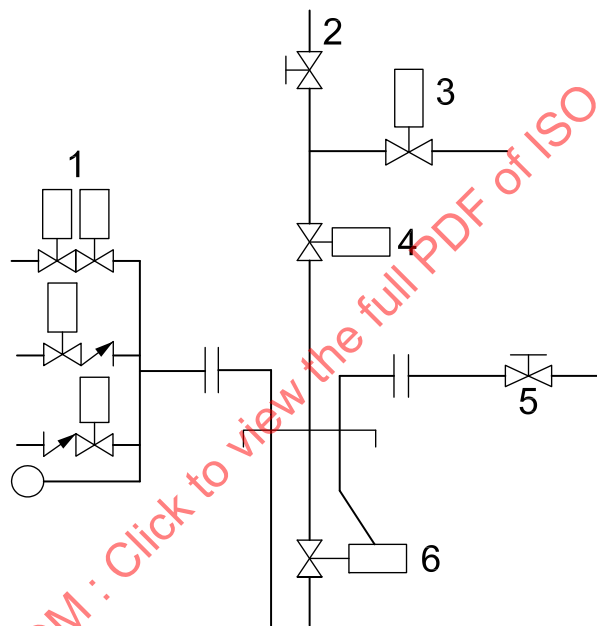

#### Key

- 1 CID
- 2 PSV
- 3 PWV
- 4 PMV
- 5 SCSSV isolation
- 6 SCSSV

NOTE The SCSSV line is designed to prevent hydraulic lock-open of SCSSV when it is disconnected.

**Figure 5 — Examples of tree valving for downhole chemical injection and SCSSV**

### 6.2.11 Downhole chemical-injection line penetrations

Two fail-closed valves are required for all chemical-injection lines that pass through the tubing hanger. Flow-closed check valves are acceptable as one of the fail-closed valves, for lines with a diameter of 25,4 mm (1,00 in) or smaller. At least one of the fail-closed valves shall be an actuated, fail-closed valve. The left side of Figure 5 illustrates typical subsea tree valving for the above. The check valve may be inboard or outboard of the fail-closed valve. Flanges, clamp hubs or OECs, as applicable, meeting the requirements of Clause 7 shall be used to provide connections for the penetrations to the tree. Threaded connections going directly into a tree body or wing-valve block for injection line penetrations when located inboard of the two closure devices are prohibited.

### 6.2.12 Pressure monitoring/test lines and internal control lines

At least one pressure-controlling closure shall be used on all pressure-monitoring/test lines that pass into or through either the tree or tubing head.

The rated working pressure of any hydraulic control line that has the potential for wellbore communication shall be equal to or greater than the working pressure of the tree. Threaded connections going directly into a tree body or wing valve block for injection-line penetrations, when located inboard of the two closure devices, are prohibited.

On lines such as connector cavity-test lines, manual isolation valves are acceptable closure devices.

### 6.2.13 Compensating barrier

Where a compensating barrier is used to exclude seawater from the actuator and to balance hydrostatic pressure, it shall be sized to accommodate a minimum of 120 % of the swept volume. A means, such as check valves, should be included in the circuit to prevent hydraulic lock. A relief device shall be included in this circuit to eliminate the chance that the failure of an actuator seal can affect the performance of the remaining valves. The manufacturer shall document the compensation fill procedure.

### 6.2.14 Downhole hydraulic control line penetrations for intelligent well completions

At least one pressure-controlling closure shall be used in all hydraulic control lines that penetrate through the tree and tubing head and that are used to operate downhole, intelligent, well-completion systems.

Manual valves (diver-/ROV-/ROT-operated) or remotely operated fail-closed valves are acceptable closing devices for intelligent well-control systems that are operated by a hydraulic power source that is connected to the tree only by a diver/ROV/ROT during a well intervention.

Remotely operated fail-closed valves are acceptable closure devices for intelligent well-control systems that are operated remotely through the production control umbilical.

Closure devices should be kept in the closed position at all times except while the intelligent well-control system is being operated. When a control pod is used to operate the intelligent well-control system, the intelligent well-control functions shall be vented through a hydraulic circuit other than the one(s) used to vent fluid/pressure from other control functions on the tree, including the SCSSV.

Thermal expansion of the hydraulic fluid in the intelligent well-control lines should be considered in the design and operation of the intelligent well-control system. Intelligent well-control line circuits should be designed to have a RWP that is greater than the well shut-in pressure.

Flanges, clamp hubs or OECs, as applicable, meeting the requirements of Clause 7 shall be used to provide connections for the intelligent well-control penetrations to the tree. Threaded connections going directly into a tree body or wing-valve block for intelligent well-control line penetrations are prohibited.

Check valves should not be used anywhere in the intelligent well control circuit if their closure could prevent the intelligent well control from being operated properly.

## 6.3 Testing of subsea tree assemblies

### 6.3.1 Validation testing

There are no validation testing requirements for subsea tree assemblies. However, all parts and equipment covered in Clause 7 used in the assembly of subsea trees shall conform to its applicable validation testing requirements.



### 6.3.2 Factory acceptance testing

The subsea tree assembly shall be factory acceptance tested in accordance with the manufacturer's written specification using the actual mating equipment or an appropriate test fixture that simulates the applicable guidebase (CGB, PGB, GRA, tree frame, etc.), wellhead and tubing hanger interfaces. See Clause 5 for testing requirements.

Because of the different subsea tree configurations, components can be directly exposed to wellbore fluid in some instances or serve as a second barrier in others. To that end, Table 4 is provided as a pictorial representation to clarify where the components are located and what hydrostatic test pressures are required with respect to body, interface, and lockdown retention testing. Detailed test requirements for each element/location are described in the applicable clauses within this part of ISO 13628.

STANDARDSISO.COM : Click to view the full PDF of ISO 13628-4:2010

Table 4 — Pressure test pictorial representations

Position	Description	RWP	Hydrostatic body test pressure	Lockdown retention test pressure
<b>a) Vertical subsea tree</b>				
A	Subsea wellhead	1,0 × RWP	1,5 × RWP	NA
B	Tubing head connector, Tubing head and tree connector	1,0 × RWP	1,5 × RWP	NA
C	Valves, valve block	1,0 × RWP	1,5 × RWP	NA
D	SCSSV flow passages and seal sub (pressure-containing)	1,0 × RWP up to RWP + 17,2 MPa (2 500 psi) max.	1,5 × RWP up to 1,5 × [RWP + 17,2 MPa (2 500 psi)]	NA
	SCSSV flow passages and seal sub (pressure-controlling)	1,0 × RWP up to RWP + 17,2 MPa (2 500 psi) max.	1,0 × RWP up to 1,0 × [(RWP + 17,2 MPa (2 500 psi)]	NA
E	Tree cap (passages and lock mechanism)	1,0 × RWP	1,5 × RWP	NA
F	Tubing hanger	1,0 × RWP	1,5 × RWP	NA
L1	Below installed tubing hanger	NA	NA	1,1 × RWP
L2 (not shown)	Above tubing plug	NA	NA	1,0 × RWP
	Below tubing plug	NA	NA	1,1 × RWP
L3	Gallery	1,0 × RWP up to RWP + 17,2 MPa (2 500 psi) max.	NA	NA

b) Horizontal subsea tree with separate internal tree cap

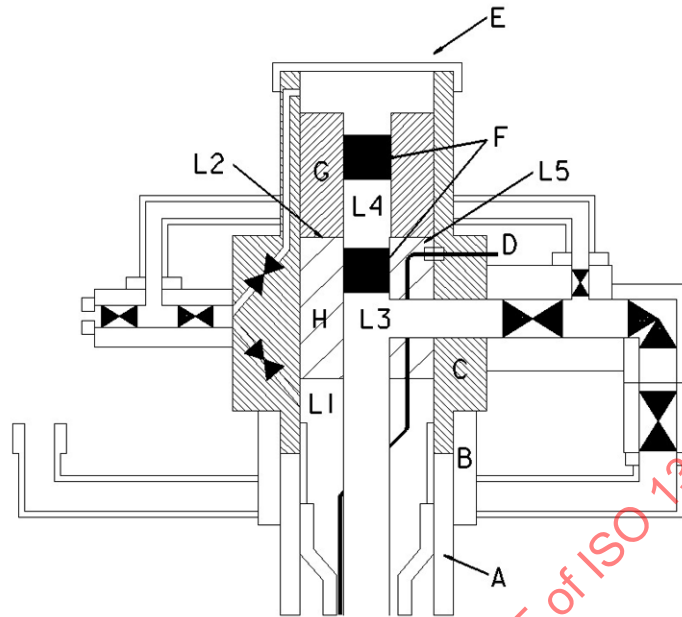

Position	Description	RWP	Hydrostatic body test pressure	Lockdown retention test pressure
A	Subsea wellhead	1,0 × RWP	1,5 × RWP	NA
B	Tree connector	1,0 × RWP	1,5 × RWP	NA
C	Valves, valve block	1,0 × RWP	1,5 × RWP	NA
D	SCSSV flow passages and seal sub (pressure-containing)	1,0 × RWP up to RWP + 17,2 MPa (2 500 psi) max.	1,5 × RWP up to 1,5 × [RWP + 17,2 MPa (2 500 psi)]	NA
	SCSSV flow passages and seal sub (pressure-controlling)	1,0 × RWP up to RWP + 17,2 MPa (2 500 psi) max.	1,0 × RWP up to 1,0 × [RWP + 17,2 MPa (2 500 psi)]	NA
E	Debris cap	PMR	PMR	NA
F	Crown plugs	1,0 × RWP	1,5 × RWP	NA
G	Internal tree cap	1,0 × RWP	1,5 × RWP	NA
H	Tubing hanger	1,0 × RWP	1,5 × RWP	NA
L1	Below installed tubing hanger	NA	NA	1,5 × RWP
L2	Below internal tree cap	NA	NA	1,5 × RWP
L3	Above lower crown plug <sup>a</sup>	NA	NA	1,0 × RWP
	Below lower crown plug <sup>a</sup>	NA	NA	1,5 × RWP
L4	Above upper crown plug	NA	NA	1,0 × RWP
	Below upper crown plug <sup>a</sup>	NA	NA	1,5 × RWP
L5	Gallery	1,0 × RWP up to RWP + 17,2 MPa (2 500 psi) max.	NA	NA

<sup>a</sup> If a lower crown plug is in place during the upper-crown-plug test from below, then the lower crown plug shall be pressure-equalized from above and below the lower crown plug during the test.

c) Horizontal subsea tree without separate internal tree cap

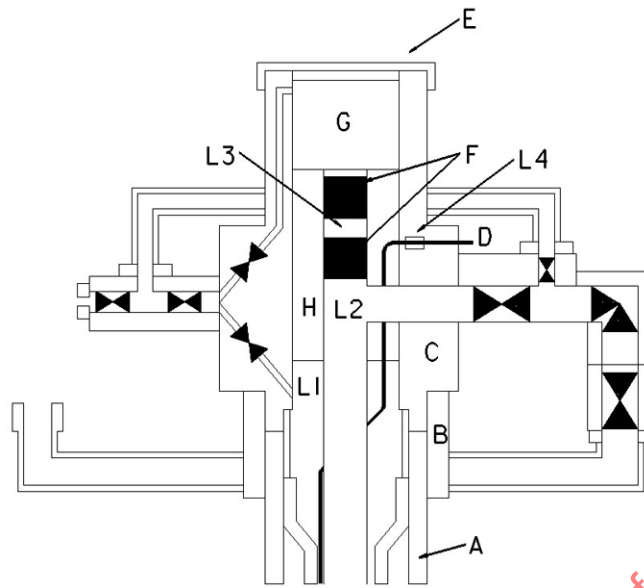

Position	Description	RWP	Hydrostatic body test pressure	Lockdown retention test pressure
A	Subsea wellhead	1,0 × RWP	1,5 × RWP	NA
B	Tree connector	1,0 × RWP	1,5 × RWP	NA
C	Valves, valve block	1,0 × RWP	1,5 × RWP	NA
D	SCSSV flow passages and seal sub (pressure-containing)	1,0 × RWP up to RWP + 17,2 MPa (2 500 psi) max.	1,5 × RWP up to 1,5 × [RWP + 17,2 MPa (2 500 psi)]	NA
	SCSSV flow passages and seal sub (pressure-controlling)	1,0 × RWP up to RWP + 17,2 MPa (2 500 psi) max.	1,0 × RWP up to 1,0 × [RWP + 17,2 MPa (2 500 psi)]	NA
E	Debris cap	PMR	PMR	NA
F	Crown plugs	1,0 × RWP	1,5 × RWP	NA
G	ROV tree cap	PMR	PMR	NA
H	Tubing hanger	1,0 × RWP	1,5 × RWP	NA
L1	Below installed tubing hanger	NA	NA	1,5 × RWP
L2	Above lower crown plug <sup>a</sup>	NA	NA	1,0 × RWP
	Below lower crown plug <sup>a</sup>	NA	NA	1,5 × RWP
L3	Above upper crown plug	NA	NA	1,0 × RWP
	Below upper crown plug <sup>a</sup>	NA	NA	1,5 × RWP
L4	Gallery	1,0 × RWP up to RWP + 17,2 MPa (2 500 psi) max.	NA	NA

<sup>a</sup> If a lower crown plug is in place during the upper-crown-plug test from below, then the lower crown plug shall be pressure-equalized from above and below the lower crown plug during the test.

## 6.4 Marking

The subsea tree assembly shall be tagged with a nameplate labelled as "Subsea tree assembly", located on the master valve or tree valve block, and contain the following information as a minimum:

- name and location of assembler/date;
- PSL designation of assembly;
- rated working pressure of assembly;
- temperature rating of assembly;
- material class of assembly (including maximum H<sub>2</sub>S partial pressure if applicable);
- unique identifier (serial number);
- ISO 13628-4.

## 6.5 Storing and shipping

Any disassembly, removal or replacement of parts or equipment after testing shall be as agreed with the purchaser.

The shipping weight of the subsea tree, including balance weights, should be kept to a minimum. In many cases, maximum lift weight can be restricted by rig-crane limitations in accordance with local legislation or regulations.

## 7 Specific requirements — Subsea-tree-related equipment and sub assemblies

### 7.1 Flanged end and outlet connections

#### 7.1.1 General — Flange types

Clause 7 specifies the ISO (API) type end and outlet flanges used on subsea completions equipment. Table 5 lists the types and sizes of flanges covered by this part of ISO 13628.

**Table 5 — Rated working pressures and size ranges of ISO (API) flanges**

Rated working pressure		Flange size range					
		Type 17SS		Type 17SV		Type 6BX	
MPa	(psi)	mm	(in)	mm	(in)	mm	(in)
34,5	(5 000)	52 to 346	(2 1/16 to 13 5/8)	52 to 346	(2 1/16 to 13 5/8)	346 to 540	(13 5/8 to 21 1/4)
69,0	(10 000)	—	—	46 to 346	(1 13/16 to 13 5/8)	46 to 540	(1 13/16 to 21 1/4)
103,5	(15 000)	—	—	—	—	46 to 496	(1 13/16 to 18 3/4)

Standard flanges for subsea completion equipment with working pressures of 34,5 MPa (5 000 psi) and below in sizes of 52 mm (2 1/16 in) through 346 mm (13 5/8 in) shall be type 17SS flanges as defined in 7.1.2.2. Type 17SS flanges are based on type 6B flanges, as defined in ISO 10423, modified slightly for consistency with established subsea practice. The primary modifications are substitution of BX type ring gaskets for

subsea service and slight reductions of through-bore diameters on some flange sizes. Type 17SS flanges have been developed for the sizes and rated working pressures given in Table 7.

Standard flanges for 34,5 MPa (5 000 psi) and below in sizes of 346 mm (13 5/8 in) through 540 mm (21 1/4 in) shall be type 6BX flanges as defined in ISO 10423.

Standard flanges for subsea completions with maximum working pressures of 69 MPa (10 000 psi) or 103,5 MPa (15 000 psi) shall be type 6BX flanges as defined in ISO 10423. ISO-type flanges for subsea completions may be either integral, blind or welding neck flanges. Threaded flanges, as defined in ISO 10423, shall not be used on subsea completion equipment handling produced fluids, except as specified in 7.3.

Segmented flanges shall not be used.

Swivel flanges are often used to facilitate subsea flowline connections that are made up underwater. Type 17SV flanges, as defined herein, have been developed as the standard swivel-flange design for subsea completions in the sizes and working pressures given in Table 5. Type 17SV swivel flanges are designed to mate with standard ISO-type 17SS and type 6BX flanges of the same size and pressure rating.

All end and outlet flanges used on subsea completion equipment shall have their ring grooves either manufactured from or inlaid with corrosion-resistant material in accordance with 7.1-2.5.5.

## 7.1.2 Design

### 7.1.2.1 General

All flanges used on subsea completions equipment shall be of the ring-joint type designed for face-to-face make-up. The connection make-up force and external loads shall react primarily on the raised face of the flange. Therefore, at least one of the flanges in a connection shall have a raised face.

All flanged connections that are made up underwater in accordance with the manufacturer's written specification shall be equipped with a means to vent any trapped fluids. Type SBX ring gaskets, as shown in Table 6, are an acceptable means for venting type 6BX, 17SS, or 17SV flanges. Type SBX or ISO 10423-type BX ring gaskets, are acceptable for 6BX, 17SS or 17SV flanges made up in air.

Other proprietary flange and seal designs that eliminate the trapped fluid problem have been developed and these are, therefore, well suited for underwater make-up. These proprietary flange and seal designs shall comply with 7.4.

Trapped fluid can also interfere with the proper make-up of studs or bolts installed into blind holes underwater. Means shall be provided for venting such trapped fluid from beneath the studs (such as holes or grooves in the threaded hole and/or the stud).

### 7.1.2.2 Standard subsea flanges — Type 17SS flanges with working pressures up to 34,5 MPa (5 000 psi)

#### 7.1.2.2.1 General

52 mm (2 1/16 in) through 279 mm (11 in) type 17SS flange designs are based on type 6B flange designs as defined in ISO 10423, but they have been modified to incorporate type BX ring gaskets (the established practice for subsea completions) rather than type R or RX gaskets. In addition, type 17SS flanges shall be designed with raised faces for rigid face-to-face make-up.

34,5 MPa (5 000 psi) type 17SS flanges shall be used for all 52 mm (2 1/16 in) through 279 mm (11 in) subsea-completion ISO-type flange applications at or below 34,5 MPa (5 000 psi) working pressure.

346 mm (13 5/8 in) through 540 mm (21 1/4 in) standard subsea flanges for working pressures of 34,5 MPa (5 000 psi) and below shall be type 6BX flanges as defined in ISO 10423.

Table 6 — API type SBX pressure-energized ring gaskets

Dimensions in millimetres (inches) unless otherwise indicated

Key	Tolerances, expressed in millimetres (inches)
1 OD, outer diameter of ring	$+0,5 \begin{pmatrix} +0,020 \\ 0 \end{pmatrix}$
2 ODT, outside diameter T	$+0,15 \begin{pmatrix} +0,006 \\ 0 \end{pmatrix}$
3 C width of flat	$+0,5 \begin{pmatrix} +0,02 \\ 0 \end{pmatrix}$
4 $R_1$ radius in ring	$+0,2 \begin{pmatrix} +0,008 \\ 0 \end{pmatrix}$
5 H <sup>a</sup> height of ring	$+0,2 \begin{pmatrix} +0,008 \\ 0 \end{pmatrix}$
6 A <sup>a</sup> width of ring	$+0,2 \begin{pmatrix} +0,008 \\ 0 \end{pmatrix}$
7 E depth of groove	$+0,8, -0 \begin{pmatrix} +0,02, -0,000 \end{pmatrix}$
8 G outside depth of groove	$23^\circ \pm 0^\circ 15'$
9 N width of groove	$\pm 0,2, \begin{pmatrix} \pm 0,008 \\ \text{max.} \end{pmatrix}$
10 R <sub>2</sub> radius in groove	max.
11 Break sharp corner	
12 D height of chamfer	$0 \begin{pmatrix} 0 \\ -0,03 \end{pmatrix}$

NOTE 1 Radius R shall be 8 % to 12 % of the gasket height, H

NOTE 2 Two pressure passage holes in the SBX ring cross-section prevent pressure lock when connections are made up underwater. Two options are provided for drilling the pressure passage holes.

<sup>a</sup> A plus tolerance of 0,2 mm (0,008 in) for width A and height H is permitted, provided the variation in width or height of any ring does not exceed 0,1 mm (0,004 in) along its entire circumference.

Table 6 (continued)

Ring number	Size		Outside diameter of ring		Height of ring <sup>f</sup>		Width of ring <sup>f</sup>		Diameter of flat		Width of flat		Hole size		Depth of groove		Outside diameter of groove		Width of groove			
	mm	(in)	mm	(in)	mm	(in)	mm	(in)	mm	(in)	mm	(in)	mm	(in)	mm	(in)	mm	(in)	mm	(in)	mm	(in)
SBX 149	19	(3/4)	42,647	(1,679)	9,627	(0,379)	7,518	(0,296)	41,326	(1,627)	6,121	(0,241)	1,5	(0,06)	5,842	(0,23)	44,221	(1,741)	9,677	(0,381)		
SBX 150	25	(1)	72,19	(2,842)	9,30	(0,366)	9,30	(0,366)	70,87	(2,790)	7,98	(0,314)	1,5	(0,06)	5,59	(0,22)	73,48	(2,893)	11,43	(0,450)		
SBX 151	46	(1 11/16)	76,40	(3,008)	9,63	(0,379)	9,63	(0,379)	75,03	(2,954)	8,26	(0,325)	1,5	(0,06)	5,56	(0,22)	77,79	(3,062)	11,84	(0,466)		
SBX 152	52	(2 1/16)	84,68	(3,334)	10,24	(0,403)	10,24	(0,403)	83,24	(3,277)	8,79	(0,346)	1,5	(0,06)	5,95	(0,23)	86,23	(3,395)	12,65	(0,498)		
SBX 153	65	(2 9/16)	100,94	(3,974)	11,38	(0,448)	11,38	(0,448)	99,31	(3,910)	9,78	(0,385)	1,5	(0,06)	6,75	(0,27)	102,77	(4,046)	14,07	(0,554)		
SBX 154	78	(3 1/16)	116,84	(4,600)	12,40	(0,488)	12,40	(0,488)	115,09	(4,531)	10,64	(0,419)	1,5	(0,06)	7,54	(0,30)	119,00	(4,685)	15,39	(0,606)		
SBX 155	103	(4 1/16)	147,96	(5,825)	14,22	(0,560)	14,22	(0,560)	145,95	(5,746)	12,22	(0,481)	1,5	(0,06)	8,33	(0,33)	150,62	(5,930)	17,73	(0,698)		
SBX 156	179	(7 1/16)	237,92	(9,367)	18,62	(0,733)	18,62	(0,733)	235,28	(9,263)	15,98	(0,629)	3,0	(0,12)	11,11	(0,44)	241,83	(9,521)	23,39	(0,921)		
SBX 157	228	(9)	294,46	(11,593)	20,98	(0,826)	20,98	(0,826)	291,49	(11,476)	18,01	(0,709)	3,0	(0,12)	12,70	(0,50)	299,06	(11,774)	26,39	(1,039)		
SBX 158	279	(11)	352,04	(13,860)	23,14	(0,911)	23,14	(0,911)	348,77	(13,731)	19,86	(0,782)	3,0	(0,12)	14,29	(0,56)	357,23	(14,064)	29,18	(1,149)		
SBX 159	346	(13 5/8)	426,72	(16,800)	25,70	(1,012)	25,70	(1,012)	423,09	(16,657)	22,07	(0,869)	3,0	(0,12)	15,88	(0,62)	432,64	(17,033)	32,49	(1,279)		
SBX 160	346	(13 5/8)	402,59	(15,850)	23,83	(0,938)	13,74	(0,541)	399,21	(15,717)	10,36	(0,408)	3,0	(0,12)	14,29	(0,56)	408,00	(16,063)	19,96	(0,786)		
SBX 161	422	(16 5/8)	491,41	(19,347)	28,07	(1,105)	16,21	(0,638)	487,45	(19,191)	12,24	(0,482)	3,0	(0,12)	17,07	(0,67)	497,94	(19,604)	23,62	(0,930)		
SBX 162	422	(16 5/8)	475,49	(18,720)	14,22	(0,560)	14,22	(0,560)	473,48	(18,641)	12,22	(0,481)	1,5	(0,06)	8,33	(0,33)	487,33	(18,832)	17,91	(0,705)		
SBX 163	476	(18 3/4)	556,16	(21,896)	30,10	(1,185)	17,37	(0,684)	551,89	(21,728)	13,11	(0,516)	3,0	(0,12)	18,26	(0,72)	563,50	(22,185)	25,55	(1,006)		
SBX 164	476	(18 3/4)	570,56	(22,463)	30,10	(1,185)	24,59	(0,968)	566,29	(22,295)	20,32	(0,800)	3,0	(0,12)	18,26	(0,72)	577,90	(22,752)	32,77	(1,290)		
SBX 165	540	(21 1/4)	624,71	(24,595)	32,03	(1,261)	18,49	(0,728)	620,19	(24,417)	13,97	(0,550)	3,0	(0,12)	19,05	(0,75)	632,56	(24,904)	27,20	(1,071)		
SBX 166	540	(21 1/4)	640,03	(25,198)	32,03	(1,261)	26,14	(1,029)	635,51	(25,020)	21,62	(0,851)	3,0	(0,12)	19,05	(0,75)	647,88	(25,507)	34,87	(1,373)		
SBX 169	131,18	(5 1/8)	173,51	(6,831)	15,85	(0,624)	12,93	(0,509)	171,29	(6,743)	10,69	(0,421)	1,5	(0,06)	9,65	(0,38)	176,66	(6,955)	16,92	(0,666)		

<sup>f</sup> A plus tolerance of 0,2 mm (0,008 in) for width, A, and height, H, is permitted, provided the variation in width or height of any ring does not exceed 0,1 mm (0,004 in) throughout its entire circumference.



### 7.1.2.2.2 Dimensions

#### 7.1.2.2.2.1 Standard dimensions

Dimensions for type 17SS flanges shall conform to Figure 6 and Tables 7 through 10.

Dimensions for ring grooves shall conform to Tables 6 through 10.

#### 7.1.2.2.2.2 Integral flange exceptions

Type 17SS flanges used as end connections on subsea completion equipment may have entrance bevels, counterbores or recesses to receive running/test tools, plugs, etc. The dimensions of such entrance bevels, counterbores, and recesses are not covered by this part of ISO 13628 but shall not exceed the  $B$  dimension of Figure 6 and Tables 7 and 8. The manufacturer shall ensure that the modified integral flange designs shall meet the requirements of Clause 5.

#### 7.1.2.2.2.3 Threaded flanges

Threaded flanges shall not be used on subsea completions equipment, except as provided in 7.1.2.2.2.2 and 7.3.

#### 7.1.2.2.2.4 Welding neck flanges — Line pipe

The following conditions shall apply.

- a) Bore and wall thickness: The bore diameter,  $J_L$ , shall not exceed the values given in Table 9. The specified bore shall not result in a weld-end wall thickness less than 87,5 % of the wall thickness of the pipe to which the flange is being attached.
- b) Weld end preparation: Dimensions for weld end preparation shall conform to Figure 8.
- c) Taper: When the thickness at the welding end is at least 2,3 mm (0,09 in) greater than that of the pipe, and the additional thickness decreases the ID, the flange shall be taper-bored from the weld end at a slope not exceeding 3 to 1.

It is not intended in this part of ISO 13628 that Type 17SS welding neck flanges be welded to wellheads or tree bodies. Their purpose is to provide a welding transition between a flange and a pipe.

#### 7.1.2.2.3 Ring grooves

Corrosion-resistant, inlaid ring grooves shall comply with the requirements in Tables 6 and 10 and in ISO 10423.

#### 7.1.2.3 Standard subsea flanges — Type 6BX with working pressures of 69 MPa (10 000 psi) or 103,5 MPa (15 000 psi)

Standard flanges for subsea completion equipment with a working pressure of 69 MPa (10 000 psi) or 103,5 MPa (15 000 psi) shall comply with the requirements for type 6BX flanges, as defined in ISO 10423. These flanges are ring-joint-type flanges, designed for face-to-face make-up. The connection make-up force and external loads shall react primarily on the raised face of the flange.

Corrosion-resistant, inlaid ring grooves for type 6BX flanges shall comply with the requirements of ISO 10423.

**7.1.2.4 Special-purpose subsea flanges — Type 17SS with working pressures of 103,5 MPa (15 000 psi) or 120,7 MPa (17 500 psi)**

Special-purpose 25 mm (1 in) flanges for use with a working pressure of 103,5 MPa (15 000 psi) or 19 mm (0,75 in) flanges for use with a working pressure of 120,7 MPa (17 500 psi) for subsea completion equipment shall comply with the requirements for type 6BX flanges, as defined in Table 8. These flanges are ring-joint-type flanges, designed for face-to-face make-up. The connection make-up force and external loads react primarily on the raised face of the flange.

For the BX-150 and BX-149 ring-groove profiles, the flange's raised face profile can come very close to the heat-affected zone (HAZ) created at the outermost diameter of the CRA weld overlay during the finish machining process of the flange, which can cause inspection problems. The alternate rough/finish machine profile illustrated in Figure 7 may be used to avoid HAZ interface problems.

STANDARDSISO.COM : Click to view the full PDF of ISO 13628-4:2010

Table 7 — Basic flange and bolt dimensions for type 17SS flanges for 34,5 MPa (5 000 psi) rated working pressure

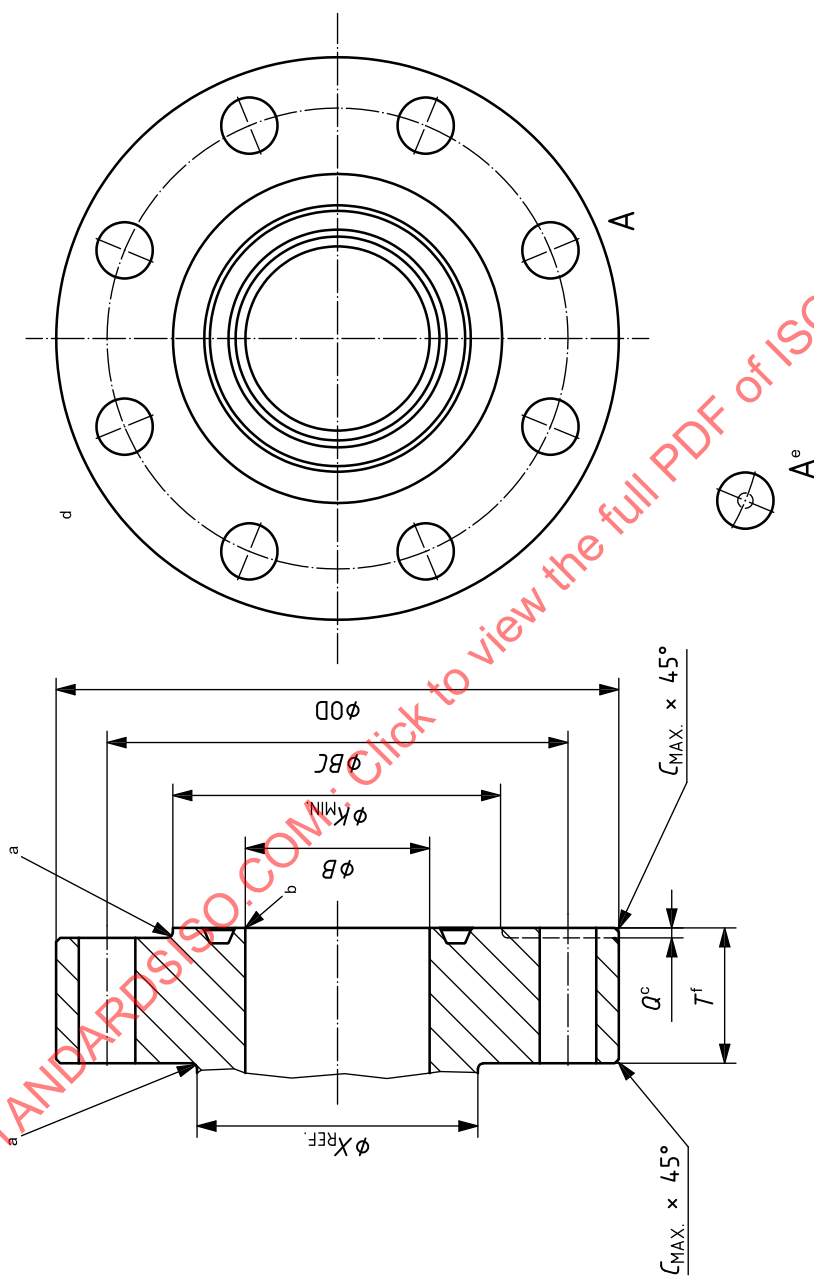

- a 3 mm (0,12 in) min. *R*.
- b Break sharp corners.
- c  $Q = 4,6 \text{ mm (0,18 in)} \pm 1,5 \text{ mm (0,06 in)}$ .
- d ring groove shall be concentric with bore within 0,3 mm (0,010 in) total indicator runoff.
- e Bolt hole centreline located within 0,8 mm (0,03 in) of theoretical B.C. and bolt holes with equal spacing.
- f  $\begin{matrix} +3 \\ 0 \end{matrix} (0,12)$ .

Table 7 (continued)

Basic flange dimensions										Bolt dimensions																
Nominal size and bore of flange	Max. bore		Outside diameter of flange		Tolerance on OD		Max. chamfer		Diameter of raised face		Total thickness of flange		Diameter of hub		Diameter of bolt circle		Number of bolts		Diameter of bolt holes		Bolt hole tolerance <sup>a</sup>		Length of stud bolts		BX ring number	
	mm	(in)	mm	(in)	mm	(in)	mm	(in)	mm	(in)	mm	(in)	mm	(in)	mm	(in)	mm	(in)	mm	(in)	mm	(in)	mm	(in)		mm
52 (2 1/16)	53,1	(2,09)	215	(8,50)	±2	(±0,06)	3	(0,12)	128	(5,03)	46,0	(1,81)	104,7	(4,12)	165,1	(6,50)	8	22	(7/8)	26	(1,00)	2	(+0,06)	155	(6,00)	152
65 (2 9/16)	65,8	(2,59)	245	(9,62)	±2	(±0,06)	3	(0,12)	147	(5,78)	49,3	(1,94)	124,0	(4,88)	190,5	(7,50)	8	25	(1)	29	(1,12)	2	(+0,06)	165	(6,50)	153
78 (3 1/8)	78,5	(3,09)	265	(10,50)	±2	(±0,06)	3	(0,12)	160	(6,31)	55,7	(2,19)	133,4	(5,25)	203,2	(8,00)	8	29	(1 1/8)	32	(1,25)	2	(+0,06)	185	(7,25)	154
103 (4 1/16)	103,9	(4,09)	310	(12,25)	±2	(±0,06)	3	(0,12)	194	(7,63)	62,0	(2,44)	162,1	(6,38)	241,3	(9,50)	8	32	(1 1/4)	36	(1,38)	2	(+0,06)	205	(8,00)	155
130 (5 1/8)	131,1	(5,16)	375	(14,75)	±2	(±0,06)	3	(0,12)	238	(9,38)	81,1	(3,19)	196,9	(7,75)	292,1	(11,50)	8	38	(1 1/2)	42	(1,62)	2	(+0,06)	255	(10,00)	169
179 (7 1/16)	180,1	(7,09)	395	(15,50)	±3	(±0,12)	6	(0,25)	272	(10,70)	92,0	(3,62)	228,6	(9,00)	317,5	(12,50)	12	35	(1 3/8)	39	(1,50)	2	(+0,06)	275	(10,75)	156
228 (9)	229,4	(9,03)	485	(19,00)	±3	(±0,12)	6	(0,25)	337	(13,25)	103,2	(4,06)	292,1	(11,50)	393,7	(15,50)	12	42	(1 5/8)	45	(1,75)	+2,5	(+0,09)	305	(12,00)	157
279 (11)	280,2	(11,03)	585	(23,00)	±3	(±0,12)	6	(0,25)	418	(16,25)	119,2	(4,69)	368,3	(14,50)	482,6	(19,00)	12	48	(1 7/8)	51	(2,00)	+2,5	(+0,09)	350	(13,75)	158
346 (13 5/8)	347,0	(13,66)	673	(26,50)	±3	(±0,12)	6	(0,25)	457	(18,00)	112,8	(4,44)	368,3	(14,50)	590,6	(23,25)	16	42	(1 5/8)	45	(1,75)	+2,5	(+0,09)	324	(12,75)	160

<sup>a</sup> Minimum bolt hole tolerance is ± 0,5 mm (0,02 in).

Table 8 — Basic flange and bolt dimensions for 19 mm (3/4 in) and 25 mm (1 in) type 17SS flanges

Basic flange dimensions										Bolt dimensions																	
Pressure rating of flange	Max. bore		Outside diameter of flange		Tolerance on OD		Max. chamfer		Diameter of raised face		Total thickness of flange		Diameter of hub		Diameter of bolt circle		Number of bolts		Diameter of bolt holes		Bolt hole tolerance <sup>a</sup>		Length of stud bolts		BX Ring number		
	MPa	(psi)	mm	(in)	mm	(in)	mm	(in)	mm	(in)	mm	(in)	mm	(in)	mm	(in)	mm	(in)	mm	(in)	mm	(in)	mm	(in)		mm	(in)
120,7	(17 500)	19	(0,75)	158,8	(6,25)	±2	(±0,06)	3	(0,12)	57,2	(2,250)	41,0	(1,62)	58,67	(2,31)	114,8	(4,52)	4	25,4	(1)	28,5	(1,06)	2	(+0,06)	140	(5,50)	149
103,5	(15 000)	26	(1,02)	171	(6,75)	±2	(±0,06)	3	(0,12)	147	(3,985)	41,0	(1,62)	58,67	(2,31)	117,3	(4,62)	4	25,4	(1)	28,5	(1,06)	2	(+0,06)	140	(5,50)	150

<sup>a</sup> Minimum bolt hole tolerance is ± 0,5 mm (0,02 in).

**Table 9 — Hub and bore dimensions for type 17SS welding neck flanges for 34,5 MPa (5 000 psi) rated working pressure**

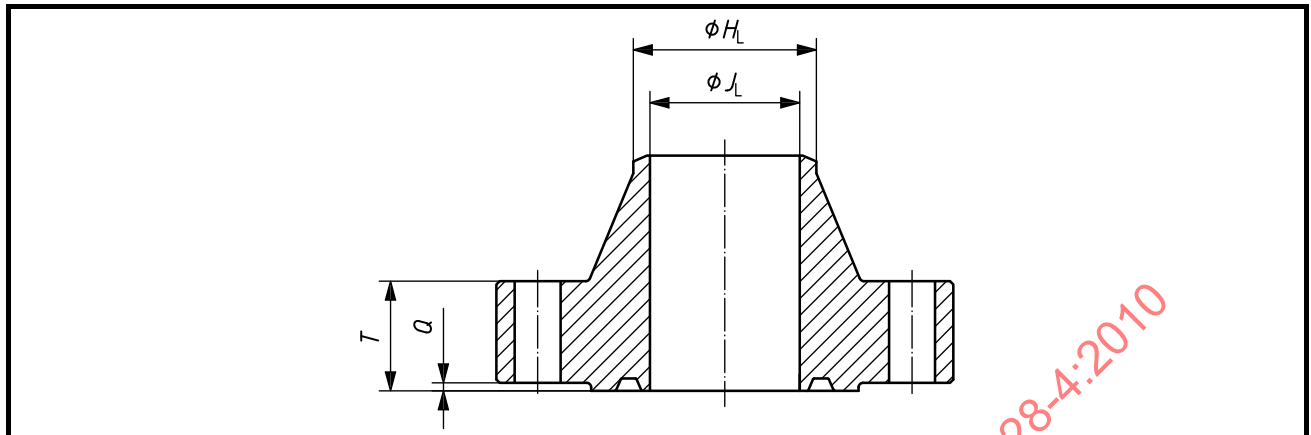

NOTE See Table 7 for dimensions  $B$ ,  $Q$ , and  $T$  and for those not shown.

Nominal size and bore of flange		Neck diameter of welding neck flange		Tolerance for $H_L$		Maximum bore of welding neck flange	
		$H_L$				$J_L \pm 0,76 (0,03)$	
mm	(in)	mm	(in)	mm	(in)	mm	(in)
52	(2 1/16)	60,5	(2,38)	+ 2 - 0,7	(+ 0,09 - 0,03)	43,0	(1,69)
65	(2 9/16)	73,2	(2,88)	+ 2 - 0,7	(+ 0,09 - 0,03)	54,1	(2,13)
98	(3 1/8)	88,9	(3,50)	+ 2 - 0,7	(+ 0,09 - 0,03)	66,5	(2,62)
103	(4 1/16)	114,3	(4,50)	+ 2 - 0,7	(+ 0,09 - 0,03)	87,4	(3,44)
130	(5 1/8)	141,2	(5,56)	+ 2 - 0,7	(+ 0,09 - 0,03)	109,5	(4,31)
179	(7 1/16)	168,4	(6,63)	+ 4 - 0,7	(+ 0,16 - 0,03)	131,0	(5,19)
228	(9)	219,2	(8,63)	+ 4 - 0,7	(+ 0,16 - 0,03)	173,0	(6,81)
279	(11)	273,1	(10,75)	+ 4 - 0,7	(+ 0,16 - 0,03)	215,9	(8,50)
346	(13 5/8)	424,0	(16,69)	+ 4 - 0,7	(+ 0,16 - 0,03)	347,0	(13,61)

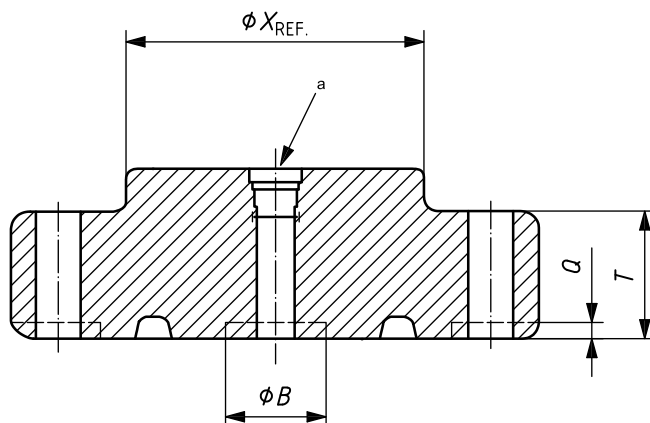

<sup>a</sup> Optional; optional porting shall have a design rating equal to or higher than the RWP of the flange.

NOTE Raised hub,  $X_{REF}$ , raised face,  $Q$ , and counterbore,  $B$ , are optional. See Table 7 or Table 8 for dimensions  $B$ ,  $X$ ,  $Q$ , and  $T$  and for those not shown.

Figure 6 — Type 17SS integral or blind flange

STANDARDSISO.COM : Click to view the full PDF of ISO 13628-4:2010

**Table 10 — Rough machining detail for corrosion-resistant API ring groove**

Dimensions in millimetres (inches) unless otherwise indicated

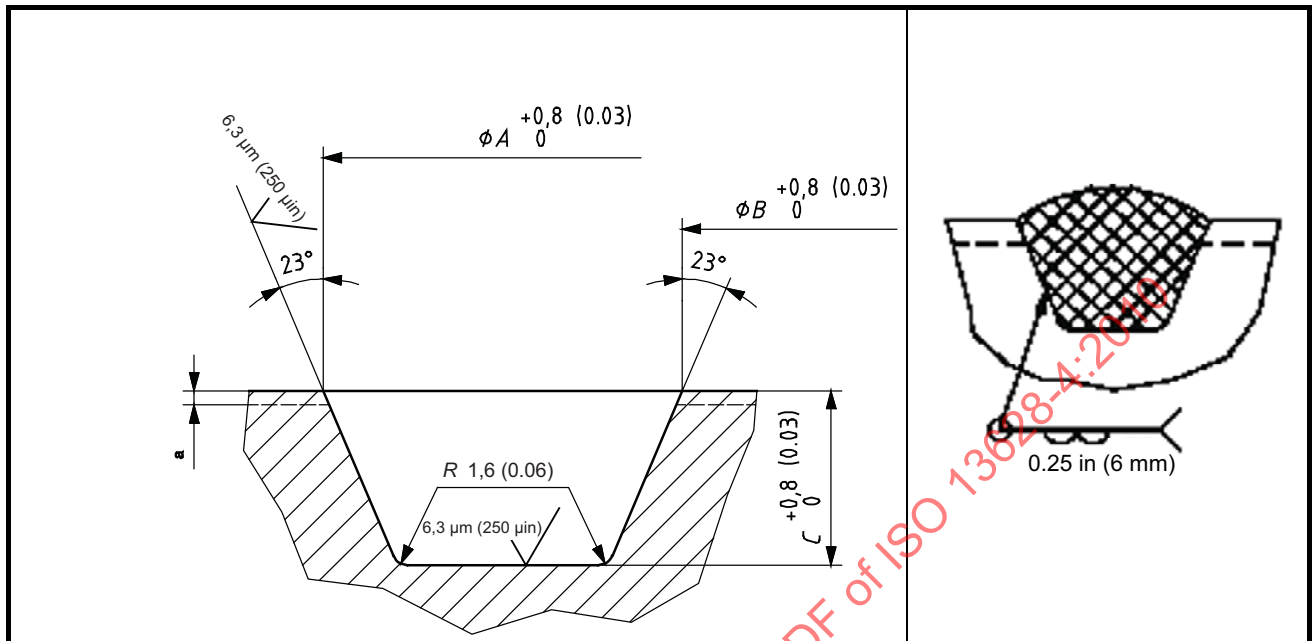

<sup>a</sup> 3,3 (0,13) allowed for finish machining.

Ring number	Outside diameter of groove		Inside diameter of groove		Depth of groove		Ring number	Outside diameter of groove		Inside diameter of groove		Depth of groove	
	A		B		C			A		B		C	
	mm	(in)	mm	(in)	mm	(in)		mm	(in)	mm	(in)	mm	(in)
BX-149	53,34	(2,100)	28,96	(1,140)	8,89	(0,350)	BX-159	443,64	(17,466)	358,75	(14,124)	22,73	(0,895)
BX-150	84,48	(3,326)	41,76	(1,644)	12,32	(0,485)	BX-160	419,00	(16,496)	359,00	(14,134)	20,96	(0,825)
BX-151	88,80	(3,496)	45,06	(1,774)	12,32	(0,485)	BX-162	489,36	(19,266)	433,43	(17,064)	15,11	(0,595)
BX-152	97,18	(3,826)	51,92	(2,044)	12,83	(0,505)	BX-163	574,45	(22,616)	503,28	(19,814)	25,02	(0,985)
BX-153	113,94	(4,486)	66,14	(2,604)	13,59	(0,535)	BX-164	588,92	(23,186)	503,02	(19,804)	25,02	(0,985)
BX-154	129,95	(5,116)	79,10	(3,114)	14,35	(0,565)	BX-165	643,53	(25,336)	568,81	(22,394)	25,78	(1,015)
BX-155	161,70	(6,366)	106,27	(4,184)	15,11	(0,595)	BX-166	659,03	(25,946)	596,06	(22,404)	25,78	(1,015)
BX-156	252,88	(9,956)	185,78	(7,314)	17,91	(0,705)	BX-167	779,42	(30,686)	713,33	(28,084)	25,78	(1,105)
BX-157	310,03	(12,206)	236,83	(9,324)	19,43	(0,765)	BX-168	785,27	(30,916)	713,59	(28,094)	25,78	(1,105)
BX-158	368,20	(14,496)	289,92	(11,414)	20,96	(0,825)	BX-169	187,86	(7,396)	133,96	(5,274)	16,38	(0,645)

Dimensions in millimetres (inches)

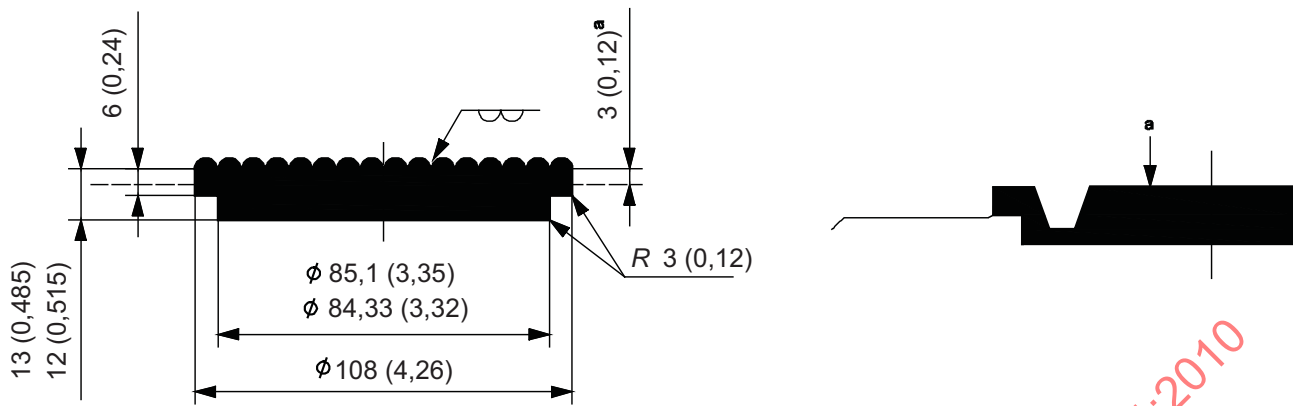

a Face off for final machine.

**Figure 7 — Alternate rough and finish machining detail for corrosion-resistant BX-149 and -150 ring grooves**

This alternate weld preparation may be employed only where the strength of the overlay alloy equals or exceeds the strength of the base material and volumetric NDE is performed on the weld metal and fusion zone with the same acceptance criteria as is used for the base metal.

All overlay material shall be compatible in accordance with the manufacturer's written specification with well fluids, inhibition fluids, injection fluids, etc., and with both the base metal of the flange and the ring gasket material (welding, galling and dissimilar metals corrosion).

Dimensions in millimetres (inches) unless otherwise indicated

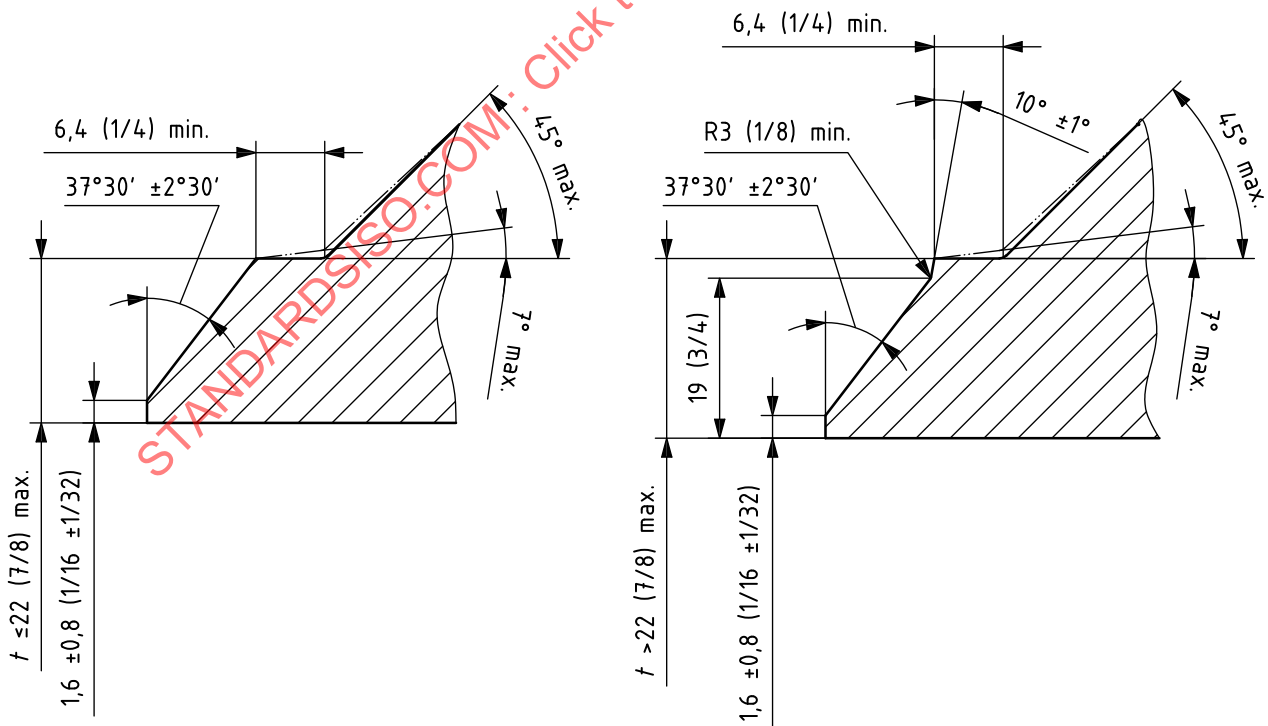

a) For neck thickness  $\leq 22$  (7/8)

b) For neck thickness  $> 22$  (7/8)

**Figure 8 — Weld end preparation for types 17SS and 17SV welding neck flanges**



### 7.1.2.5 Swivel flanges — Type 17S for working pressures 34,5 MPa (5 000 psi) or 69 MPa (10 000 psi)

#### 7.1.2.5.1 General

Type 17SV flanges are multiple-piece assemblies in which the flange rim is free to rotate relative to the flange hub. A retainer groove is provided on the neck of the hub to allow installation of a snap wire of sufficient diameter to hold the ring on the hub during storage, handling and installation. Type 17SV flanges may be used on subsea completion equipment where it is difficult or impossible to rotate either of the flange hubs to align the mating bolt holes. Type 17SV flanges mate with standard types 6BX and 17SS flanges of the same size and pressure rating.

Type 17SV swivel flanges are of the ring-joint type and are designed for face-to-face make-up. The connection make-up force and external loads shall react primarily on the raised face of the flange.

#### 7.1.2.5.2 Dimensions

Dimensions for type 17SV flanges shall conform to Tables 11 through 14.

Dimensions for welding neck preparations shall conform to Figure 8 and Table 11.

Dimensions for ring grooves shall conform to Tables 6 and 10.

#### 7.1.2.5.3 Flange face

Flange faces shall be fully machined. The nut bearing surface shall be parallel to the flange gasket face within 1°. The back face may be fully machined or spot faced at the bolt holes. The thickness of type 17SS flanges and type 17SV hubs and swivel rings after facing shall meet the dimensions of Tables 7, 8, and 11 through 14, as applicable. The thickness of type 6BX flanges shall meet the requirements of ISO 10423.

#### 7.1.2.5.4 Gaskets

Types 6BX, 17SS and 17SV flanges in subsea completion equipment shall use types BX or SBX gaskets in accordance with 7.6. If these flanges are made up underwater in accordance with the manufacturer's written specification, they shall use internally cross-drilled type SBX ring gaskets to prevent fluid entrapment between the gasket and the ring groove during flange make-up.

#### 7.1.2.5.5 Corrosion-resistant ring grooves

All end and outlet flanges used on subsea completions shall be manufactured from, or inlaid with, corrosion-resistant materials with proven seawater resistance under the specified operating conditions. The chosen material shall also be resistant to corrosion from the internal fluid. Corrosion-resistant inlaid BX ring grooves shall comply with ISO 10423.

Prior to application of the overlay, preparation of the BX ring grooves shall conform to the dimensions of Table 10 as applicable, or other weld preparations may be employed where the strength of the overlay materials equals or exceeds the strength of the base material and volumetric NDE is performed on the weld metal and fusion zone with the same acceptance criteria as is used for the base metal. The overlay material shall be compatible in accordance with the manufacturer's written specification with well fluid, inhibition fluid, injection fluids, etc., and with both the base metal of the flange and the ring-gasket material (welding, galling and dissimilar metals corrosion).

#### 7.1.2.5.6 Flange materials

Flange materials shall conform to the requirements in Clause 5 as applicable and materials with a minimum yield strength of 517 MPa (75 000 psi) shall be used for type 17SV flanges for 69 MPa (10 000 psi) rated working pressure.

**Table 11 — Hub and bore dimensions for type 17SV flanges for 34,5 MPa (5 000 psi) rated working pressure**

Dimensions in millimetres (inches) unless otherwise indicated

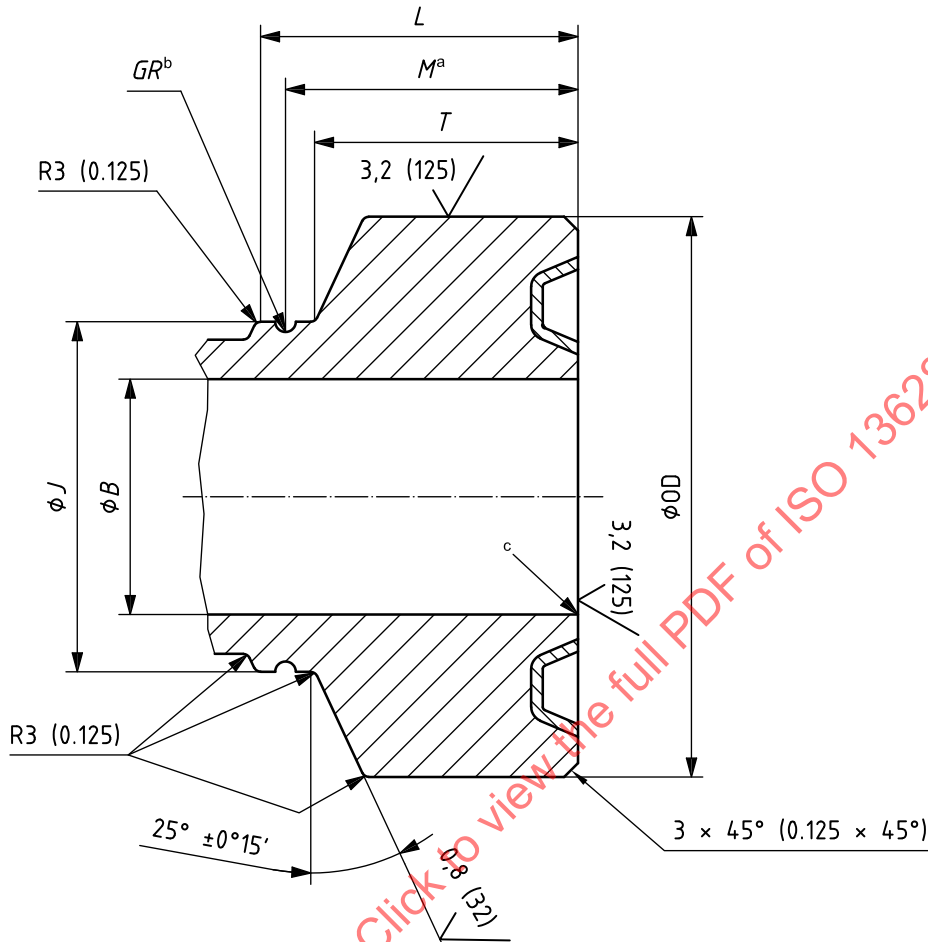

- a Groove location,  $M \begin{matrix} +0,7 \\ 0 \end{matrix} \begin{pmatrix} +0,030 \\ 0 \end{pmatrix}$ .
- b Groove radius,  $GR \begin{matrix} +0,1 \\ 0 \end{matrix} \begin{pmatrix} +0,005 \\ 0 \end{pmatrix}$ .
- c Break sharp corners.

Hub <sup>a</sup> and bore dimensions														
Nominal size and bore		Outside diameter		Total thickness		Large diameter of neck		Length of neck		Groove location		Retainer groove radius		Ring gasket no.
		OD		T		J		L		M		GR		BX
mm	(in)	mm	(in)	Mm	(in)	mm	(in)	mm	(in)	mm	(in)	mm	(in)	
52	(2 1/16)	128	(5,031)	29,5	(1,166)	93	(3,656)	84	(3,282)	74	(2,907)	3	(0,125)	152
65	(2 9/16)	147	(5,781)	29,5	(1,166)	112	(4,406)	84	(3,282)	74	(2,907)	3	(0,125)	153
78	(3 1/8)	160	(6,312)	29,5	(1,166)	126	(4,938)	88	(3,432)	78	(3,067)	3	(0,125)	154
103	(4 1/16)	194	(7,625)	30,5	(1,197)	159	(6,250)	96	(3,757)	86	(3,382)	3	(0,125)	155
130	(5 1/8)	240	(9,380)	36,0	(1,410)	197	(7,755)	121	(4,732)	111	(4,357)	3	(0,125)	169
179	(7 1/16)	272	(10,700)	41,5	(1,622)	231	(9,075)	141	(5,541)	127	(4,979)	5	(0,188)	156
228	(9)	340	(13,250)	41,5	(1,622)	296	(11,625)	156	(6,113)	141	(5,551)	5	(0,188)	157
279	(11)	415	(16,250)	42,0	(1,654)	372	(14,625)	162	(6,932)	162	(6,370)	5	(0,188)	158
346	(13 5/8)	524	(20,625)	47,52	(1,871)	489	(19,000)	182	(7,150)	168	(6,614)	5	(0,188)	160

<sup>a</sup> Hub material strength shall be equal to or greater than 517,1 MPa (75 000 psi).

Table 12 — Basic dimensions of rings and bolts for type 17SV flanges for 34,5 MPa (5 000 psi) rated working pressure

Dimensions in millimetres (inches) unless otherwise indicated

Tolerances	
<i>R</i>	(outside diameter):
	Sizes 2 1/16 to 5 1/8
	Sizes 7 1/16 to 11
<i>RL</i>	(length of ring)
<i>RT</i>	(depth of large diameter)
<i>RJ1</i>	(large-ID ring)
<i>RJ2</i>	(small-ID ring)
<i>C</i>	(chamfer)
Bolt diameter:	
	Sizes 2 1/16 to 7 1/16
	Sizes 9 to 11

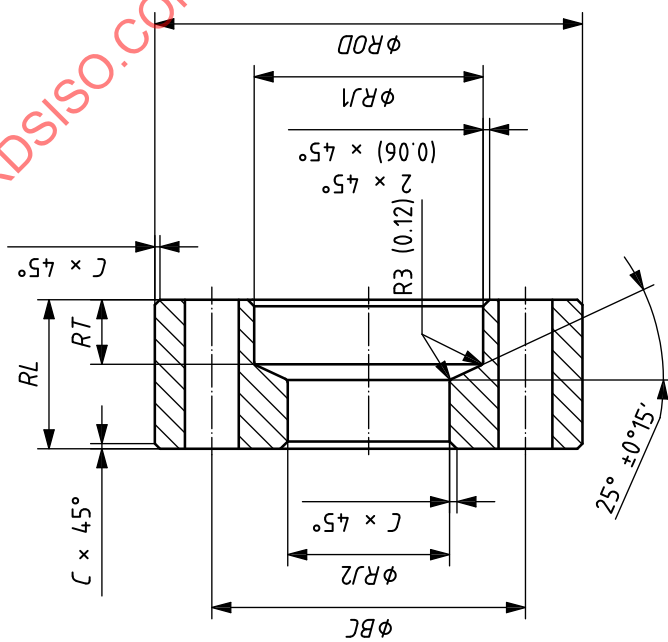

Table 12 (continued)

Nominal size and bore of hub		Outside diameter of ring <sup>a</sup>		Depth of LG ID		Large ID of ring		Small ID of ring		Length of ring		Chamfer		Diameter of bolt circle		Number of bolts	Diameter of bolt holes	
		mm	(in)	mm	(in)	mm	(in)	mm	(in)	mm	(in)	mm	(in)	mm	(in)		mm	(in)
52	(2 1/16)	216	(8,50)	24,5	(0,964)	129,4	(5,093)	94,5	(3,718)	63	(2,450)	3	(0,125)	165,1	(6,50)	8	26	(1,00)
65	(2 9/16)	246	(9,62)	24,5	(0,964)	148,5	(5,843)	113,5	(4,468)	63	(2,450)	3	(0,125)	190,5	(7,50)	8	29	(1,12)
78	(3 1/8)	267	(10,50)	24,5	(0,964)	162,0	(6,375)	127	(5,000)	66	(2,600)	3	(0,125)	203,2	(8,00)	8	32	(1,25)
103	(4 1/16)	312	(12,25)	25,3	(0,995)	195,3	(7,687)	160,4	(6,312)	75	(2,925)	3	(0,125)	241,3	(9,50)	8	36	(1,38)
130	(5 1/8)	375	(14,75)	30,7	(1,208)	239,9	(9,442)	198,6	(7,817)	99	(3,900)	3	(0,125)	292,1	(11,50)	8	42	(1,62)
179	(7 1/16)	394	(15,50)	36,1	(1,420)	273,4	(10,762)	232,1	(9,157)	114	(4,459)	5	(0,188)	317,5	(12,50)	12	39	(1,50)
228	(9)	483	(19,00)	36,1	(1,420)	338,2	(13,312)	296,9	(11,687)	128	(5,031)	5	(0,188)	393,7	(15,50)	12	45	(1,75)
279	(11)	585	(23,00)	36,9	(1,452)	414,4	(16,312)	373,1	(14,687)	149	(5,850)	5	(0,188)	482,6	(19,00)	12	51	(2,00)
346	(13 5/8)	673	(26,50)	42,4	(1,670)	525,4	(20,687)	484,2	(19,062)	154	(6,062)	5	(0,188)	590,6	(23,25)	16	45	(1,75)

<sup>a</sup> Ring material strength shall be equal to or greater than 517,1 MPa (75 000 psi).

Table 13 — Hub dimensions for type 17SV flanges for 69 MPa (10 000 psi) rated working pressure

Dimensions in millimetres (inches)

Hub <sup>a</sup> dimensions														
Nominal size and bore		Outside diameter		Total thickness		Large diameter of neck		Length of neck		Groove location		Retainer groove radius		Ring gasket no.
		OD		<i>T</i>		<i>J</i>		<i>L</i>		<i>M</i>		<i>RG</i>		<i>BX</i>
mm	(in)	mm	(in)	mm	(in)	mm	(in)	mm	(in)	mm	(in)	mm	(in)	
46	(1 13/16)	115	(4,500)	29,5	(1,166)	82,6	(3,250)	84	(3,282)	74	(2,907)	3	(0,125)	151
52	(2 1/16)	130	(5,000)	29,5	(1,166)	95,3	(3,750)	84	(3,282)	74	(2,907)	3	(0,125)	152
65	(2 9/16)	150	(5,800)	29,5	(1,166)	115,6	(4,550)	84	(3,302)	75	(2,927)	3	(0,125)	153
78	(3 1/16)	175	(6,930)	30,5	(1,197)	144,3	(5,680)	93	(3,666)	84	(3,291)	3	(0,125)	154
103	(4 1/16)	215	(8,437)	33,3	(1,310)	178,0	(6,812)	109	(4,277)	99	(3,902)	3	(0,125)	155
130	(5 1/8)	225	(9,960)	38,1	(1,500)	211,7	(8,335)	121	(4,732)	111	(4,357)	3	(0,125)	169
179	(7 1/16)	350	(13,660)	42,0	(1,653)	305,7	(12,035)	158	(6,204)	143	(5,641)	5	(0,188)	156
228	(9)	415	(16,250)	42,0	(1,653)	371,5	(14,625)	185	(7,270)	170	(6,707)	5	(0,188)	157
279	(11)	480	(18,870)	51,7	(2,035)	438,0	(17,245)	207	(8,153)	193	(7,591)	5	(0,188)	158
346	(13 5/8)	565	(22,250)	58,7	(2,309)	523,9	(20,625)	242	(9,531)	228	(8,969)	5	(0,188)	159

<sup>a</sup> Hub material strength shall be equal to or greater than 517,1 MPa (75 000 psi).

**Table 14 — Basic ring and bolt dimensions for type 17SV flanges for 69 MPa (10 000 psi) rated working pressure**

Dimensions in millimetres (inches) unless otherwise indicated

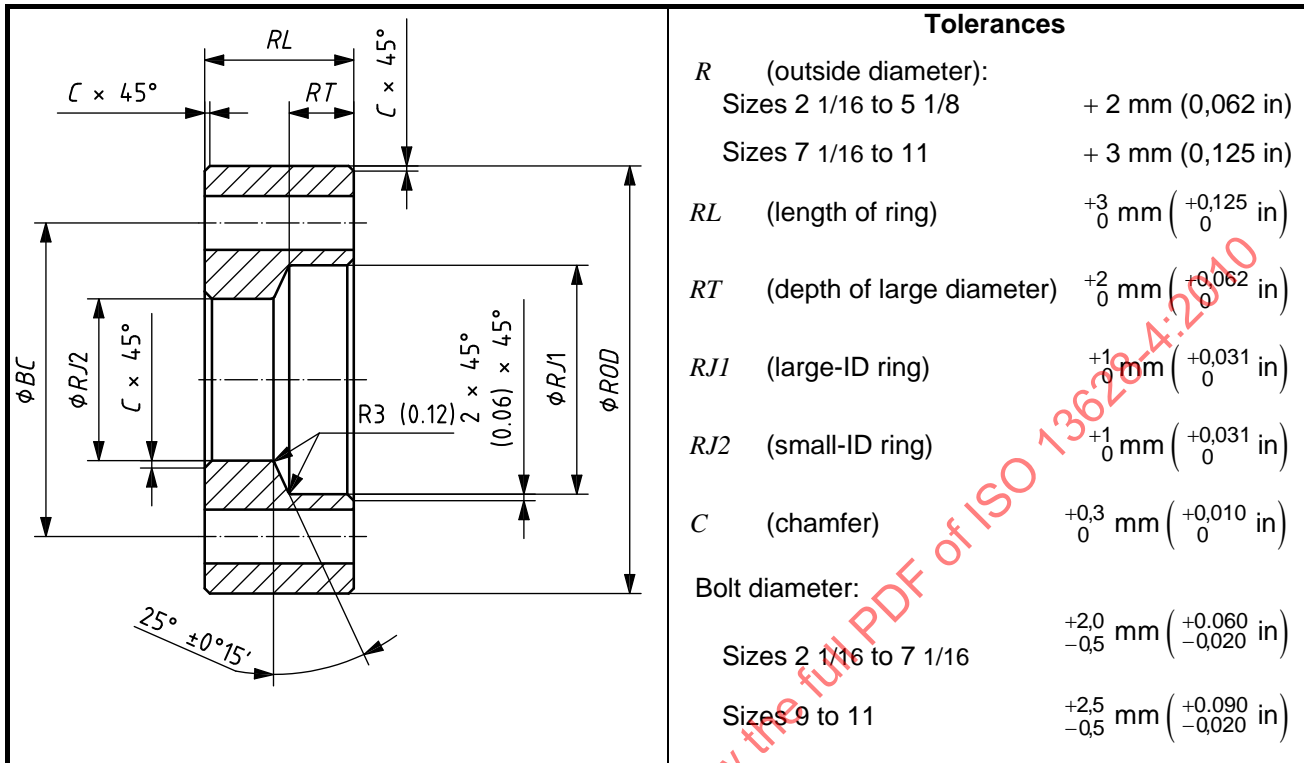

Tolerances	
<i>R</i> (outside diameter):	
Sizes 2 1/16 to 5 1/8	+ 2 mm (0,062 in)
Sizes 7 1/16 to 11	+ 3 mm (0,125 in)
<i>RL</i> (length of ring)	$+3_0$ mm ( $+0,125_0$ in)
<i>RT</i> (depth of large diameter)	$+2_0$ mm ( $+0,062_0$ in)
<i>R/1</i> (large-ID ring)	$+1_0$ mm ( $+0,031_0$ in)
<i>R/2</i> (small-ID ring)	$+1_0$ mm ( $+0,031_0$ in)
<i>C</i> (chamfer)	$+0,3_0$ mm ( $+0,010_0$ in)
Bolt diameter:	
Sizes 2 1/16 to 7 1/16	$+2,0_{-0,5}$ mm ( $+0,060_{-0,020}$ in)
Sizes 9 to 11	$+2,5_{-0,5}$ mm ( $+0,090_{-0,020}$ in)

Basic dimensions of ring <sup>a</sup>						Bolts						
Large ID of ring		Small ID of ring		Length of ring		Chamfer		Diameter of bolt circle		Number of bolts	Diameter of bolt holes	
<i>R/1</i>		<i>R/2</i>		<i>RL</i>		<i>C</i>		<i>BC</i>			mm	(in)
mm	(in)	mm	(in)	mm	(in)	mm	(in)	mm	(in)			
115,9	(4,562)	84,1	(3,312)	63	(2,450)	3	(0,125)	146,1	(5,75)	8	23	(0,88)
128,6	(5,062)	96,8	(3,812)	63	(2,450)	3	(0,125)	158,8	(6,25)	8	23	(0,88)
148,9	(5,862)	117,1	(4,612)	63	(2,470)	3	(0,125)	184,1	(7,25)	8	26	(1,00)
177,6	(6,992)	145,8	(5,742)	72	(2,834)	3	(0,125)	215,9	(8,50)	8	29	(1,12)
215,9	(8,500)	174,6	(6,875)	88	(3,445)	3	(0,125)	258,8	(10,19)	8	32	(1,25)
254,6	(10,022)	213,3	(8,397)	99	(3,900)	3	(0,125)	300,0	(11,81)	12	32	(1,25)
348,5	(13,722)	307,3	(12,097)	130	(5,122)	5	(0,188)	403,4	(15,98)	12	42	(1,62)
409,7	(16,342)	373	(14,687)	158	(6,188)	5	(0,188)	496,3	(19,53)	16	42	(1,62)
480,9	(18,932)	439,6	(17,307)	180	(7,072)	5	(0,188)	565,2	(22,25)	16	48	(1,88)
566,7	(22,312)	525,4	(20,687)	215	(8,450)	5	(0,188)	673,1	(26,50)	20	51	(2,00)

<sup>a</sup> Ring material strength shall be equal to or greater than 517,1 MPa (75 000 psi).

### 7.1.3 Testing

Loose flanges furnished under 7.1 do not require a hydrostatic test prior to final acceptance.

## 7.2 ISO clamp hub-type connections

API clamp-hub-type connections for use on subsea completion equipment shall comply with the dimensional requirements of ISO 13533. All end and outlet clamp hubs used on subsea completion equipment shall have their ring grooves either manufactured from, or inlaid with, corrosion resistant materials.

Corrosion-resistant inlaid ring grooves for clamp hubs shall comply with ISO 13533 (or to Figure 7 and Table 6 if BX or SBX gaskets are used). Overlays are not required if the base material is compatible with well fluids, seawater, etc.

NOTE For the purposes of this provision, API Spec 16A is equivalent to ISO 13533 (all parts).

For forged material used for pressure-containing and high-load-bearing parts, forging practices, heat treatment and test coupon (QTC or prolongation) requirements should meet those of API RP 6HT. In addition, the test coupon shall accompany the material it qualifies through all thermal processing, excluding stress relief.

## 7.3 Threaded connections

Loose-threaded flanges and other threaded end and outlet connections shall not be used on subsea completion equipment, except for tubing hangers, that handles produced fluid. Threaded flanges may be used on non-production connections, such as injection piping, provided there is an isolation valve and either a bolted flange or a clamp hub connection on the tree side of the threaded flange. Integral threaded connections, such as instrument connections, test ports, and injection/monitor connections, may be used in sizes up to 25,4 mm (1,00 in), provided they are used in conjunction with the appropriate rated working pressure defined in Table 2 and ISO 10423 and are located downstream of the first wing valve. If threaded connections are used upstream of the first wing valve, there shall be an isolation valve and either a bolted flange, clamp hub or welded connections as defined in 7.20.2.6 on the tree side of the threaded connection. Threaded bleeder/grease/injection fittings shall be allowed upstream of the first wing valve without the isolation valve and flange/clamp hub if at least two pressure barriers between the produced fluid and the external environment are provided. The sealing areas shall be made of corrosion-resistant materials.

Threaded connections used on subsea equipment covered by this part of ISO 13628 shall comply with the requirements of 5.1.2.1.7.

## 7.4 Other end connectors

The use of other non-standard end connectors, such as misalignment connectors, non-ISO flanges, ball joints, articulated jumper assemblies or instrument/monitor flanges is allowable in subsea completion equipment if these connectors have been designed, documented and tested in accordance with the requirements established in Clause 5.

Materials for OECs shall meet the requirements of 5.2 and 5.3. If the connector's primary seals are not metal-to-metal, redundant seals shall be provided. OECs used on subsea completion equipment shall have seal surfaces that engage metal-to-metal seals and shall be inlaid with a corrosion-resistant material that is compatible with well fluids, seawater, etc. Overlays are not required if the base material is a corrosion-resistant material.

For forged material used for pressure-containing and high-load-bearing parts, forging practices, heat treatment and test coupon (QTC or prolongation) requirements should meet those of API RP 6HT. In addition, the test coupon shall accompany the material it qualifies through all thermal processing, excluding stress relief.

## 7.5 Studs, nuts and bolting

### 7.5.1 General

Selection of stud, nut and bolting materials and coatings/platings should consider seawater-induced chloride stress corrosion cracking and corrosion fatigue. Hydrogen embrittlement induced by cathodic protection systems should be considered. Consideration should be given to the effect of coatings on the cathodic protection systems.

Some high-strength bolting materials might not be suitable for service in a seawater environment. Refer to 5.1.3.5.

### 7.5.2 ISO studs and nuts

The requirements for studs and nuts apply only to those used in end and outlet connections. Such studs and nuts used on subsea completion equipment covered by this part of ISO 13628 shall comply with ISO 10423.

### 7.5.3 Other studs, nuts and bolting

All other studs, nuts and bolting used on equipment shall comply with the manufacturer's written specifications.

### 7.5.4 Anti-corrosion coating/plating

The use of coatings that can be harmful to the environment or galvanically active should be avoided. Local legislation should be checked for coatings deemed hazardous.

### 7.5.5 Make-up torque requirements

Make-up requirements shall comply with 5.1.3.5.

Studs, nuts and other closure bolting for subsea service are often manufactured with anti-corrosion coatings/platings which can dramatically affect the stud-to-nut friction factor. Manufacturers shall document recommended make-up tension (or torque) for their fasteners using tables, similar to the one in Annex G.

The use of calibrated torque or bolt-tensioning equipment is recommended to ensure accurate make-up tension.

## 7.6 Ring gaskets

### 7.6.1 General

In 7.6 are covered type SBX ring gaskets for use in ISO types 6BX, 17SS, and 17SV flanged connections, and ISO 13533 clamp connections used in subsea completion equipment. Type SBX gaskets are vented to prevent pressure lock when connections are made up underwater.

Connections that are not made up underwater may use non-vented type BX gaskets.

Other proprietary gaskets shall conform to the manufacturer's written specification.

Although positioning of ring gaskets in their mating grooves is often a problem when making up flanges/clamp hubs on horizontal bores underwater, grease shall not be used to hold ring gaskets in position during make-up, since grease can interfere with proper make-up of the gasket. Likewise, the practice of tack welding rods to the OD of seal rings (to simplify positioning of the ring during make-up) shall not be used on gaskets for subsea service. Instead, gasket installation tools should be used if assistance is required to retain the gasket in position during make up.



## 7.6.2 Design

### 7.6.2.1 Dimensions

Type SBX ring gaskets shall conform to the dimensions, surface finishes, and tolerances given in Table 6 and ISO 10423.

### 7.6.2.2 Pressure passage hole

Each BX gaskets shall have one pressure passage hole drilled through its height as shown in ISO 10423.

Type BX ring gaskets are not suitable for connections that are made up underwater since fluid trapped in the ring groove can interfere with proper make up. Type SBX vented ring gaskets shall be used in place of type BX gaskets on ISO type flange connections made up underwater in accordance with the manufacturer's written specification. Type SBX ring gaskets shall conform to Table 6.

If other types of end connectors are used on equipment that is made up underwater in accordance with the manufacturer's written specification, then means shall be provided to vent trapped pressure between the gasket and the connector.

### 7.6.2.3 Reuse of gaskets

Except for testing purposes, ISO ring gaskets shall not be reused.

## 7.6.3 Materials

### 7.6.3.1 Ring gasket materials

Ring gaskets used for all pressure-containing flanged and clamped subsea connections shall be manufactured from corrosion-resistant materials. Gasket materials shall conform to the requirements of ISO 10423.

### 7.6.3.2 Coatings and platings

The thickness of coatings and platings used on ISO ring gaskets to aid seal engagement while minimizing galling shall not exceed 0,01 mm (0,000 5 in). The use of coatings that can be harmful to the environment or galvanically active should be avoided. Local legislation should be checked for coatings deemed hazardous.

## 7.7 Completion guidebase

### 7.7.1 General

The completion guidebase (CGB) is similar in function to a permanent guidebase used on a subsea wellhead. The CGB attaches to either the conductor housing (after the PGB is removed), or is attached to the tubing head connector (in the same way a tree guide frame is attached to the subsea tree connector). It provides the same guidance for the drilling and completion equipment (BOP, production tree, running tools), and also provides landing and structural support for ancillary equipment, such as remote OEC flowline connections. The CGB provides guidance of the BOP and subsea tree onto the subsea wellhead or tubing head using guideline or guidelineless methods. It also shall not interfere with BOP stack installation. Consideration shall be given to required ROV access and cuttings disposal.

Guidance and orientation with other subsea equipment shall conform with 7.15.2.1.

Guidance on design and associated load testing shall conform to the requirements in 5.1.3.6.

## 7.7.2 Design

### 7.7.2.1 Loads

The following loads should be considered and documented by the manufacturer when designing the CGB:

- guideline tension;
- flowline pull-in, connection, installation, and operational loads (refer to 7.18.2.2.1);
- annulus access connection loads;
- environmental;
- installation loads (including conductor hang off on spider beams);
- snagging loads;
- BOP and tree loads;
- ROV impact loads;
- sea fastening (when supported on spider beams).

### 7.7.2.2 Dimensions

The dimensions of the CGB shall conform to the dimensions listed in 7.15.2.1 and 8.3.2 and shown in Figure 9 a), unless the orientation system requires tighter tolerances.

## 7.8 Tree connectors and tubing heads

### 7.8.1 General

#### 7.8.1.1 Equipment covered

In 7.8 are covered the tree and tubing head connectors that attach the tree or tubing head to the subsea wellhead. In addition, tubing heads are also covered in 7.8.

#### 7.8.1.2 Tree/tubing head spool connectors

Three types of tree/spool connectors are commonly used:

- hydraulic remote operated;
- mechanical remote actuated;
- mechanical diver/ROV operated.

All connectors shall be designated by size, pressure rating and the profile type of the subsea wellhead to which they will be attached (see Table 15). Tree/spool connectors shall conform to maximum standard pressure ratings of 34,5 MPa (5 000 psi), 69 MPa (10 000 psi) or 103,5 MPa (15 000 psi), as applicable. Body proof testing shall be conducted at 1,5 times the pressure rating. The design and installed preload should give consideration to possible higher pressure from an SCSSV seal-sub leakage in the gallery inside the tree connector.

The tree connector may be a separate unit or may be integral with the XT valve block.

Table 15 — Wellhead systems — Standard sizes and types

System designation		High-pressure housing working pressure		Minimum vertical bore	
mm – Mpa	(in; psi)	MPa	(psi)	mm	(in)
476 – 69	(18 3/4; 10 000)	69,0	(10 000)	446	(17,56)
476 – 103	(18 3/4; 15 000)	103,5	(15 000)	446	(17,56)
425 – 35	(16 3/4; 5 000)	34,5	(5 000)	384	(15,12)
425 – 69	(16 3/4; 10 000)	69,0	(10 000)	384	(15,12)
527 – 540 – 14	(20 3/4; 21 1/4; 2 000)	13,8	(2 000)	472	(18,59)
346 – 69	(13 5/8; 10 000)	69,0	(10 000)	313	(12,31)
540 – 35	(21 1/4; 5 000)	34,5	(5 000)	472	(18,59)
346 – 103	(13 5/8; 15 000)	103,5	(15 000)	313	(12,31)
476 – 69	(18 3/4; 10 000)	69,0	(10 000)	446	(17,56)
346 – 103	(13 5/8; 15 000)	103,5	(15 000)	313	(12,31)

### 7.8.1.3 Tubing heads

#### 7.8.1.3.1 Uses

Tubing heads are commonly used to

- provide a crossover between wellheads and subsea trees made by different equipment manufacturers;
- provide a crossover between different sizes and/or pressure ratings of subsea wellheads and trees;
- provide a surface for landing and sealing a tubing hanger if the wellhead is damaged or is not designed to receive the hanger;
- provide a means for attaching any guidance equipment to the subsea wellhead.

#### 7.8.1.3.2 Types, sizes and pressure rating

The tubing head shall be designated by size, pressure rating, and the profile types of its top and bottom connections. Top connections are commonly either hub- or mandrel-type connections that shall match the tree connector. The bottom connection shall match the wellhead. The tubing head and connector may be manufactured as an integral unit. Tubing heads shall conform to standard pressure ratings of 34,5 MPa (5 000 psi), 69 MPa (10 000 psi) or 103,5 MPa (15 000 psi), as applicable. Body proof testing shall be conducted at 1,5 times the pressure rating. When the tubing head and connector are manufactured as an integral unit, then the pressure rating shall apply to the unit as a whole.

### 7.8.2 Design

#### 7.8.2.1 Loads/conditions

As a minimum, the following loading parameters/conditions shall be considered and documented by the manufacturer when designing the tree connector and tubing head:

- internal and external pressure;
- pressure separation loads, which shall be based on worst-case sealing conditions (leakage to the largest redundant seal diameter shall be assumed);

- mechanical preloads;
- riser bending and tension loads (completion and/or drilling riser);
- environmental loads;
- snagging loads;
- fatigue considerations;
- vibration;
- mechanical installation (impact) loads;
- hydraulic coupler/flowline stab connector thrust and/or preloads;
- thermal expansion (trapped fluids, dissimilar metals);
- BOP loads;
- tree loads;
- flowline loads;
- installation/workover;
- overpull;
- corrosion.

#### 7.8.2.2 Load/capacity

The manufacturer shall specify the loads/conditions for which the equipment is designed.

#### 7.8.2.3 Actuating pressures

Hydraulically actuated tree and tubing head connectors shall be capable of containing hydraulic release pressures of at least 1,25 times hydraulic RWP in the event that normal operating pressure is inadequate. The manufacturer shall document both normal and maximum operating pressures. The connector design shall provide greater unlocking force than locking force. It is the responsibility of the manufacturer document the connector locking and unlocking pressures and forces.

#### 7.8.2.4 Secondary release

Hydraulically actuated tree and tubing head connectors shall be designed with a secondary release method, which may be hydraulic or mechanical. Hydraulic open- and close-control line piping shall provide either a ROV/hot stab/isolation valve, or be positioned with a cut-away loop (for cutting the lines by diver/ROV) to vent pressure, if needed, to allow the secondary release to function.

#### 7.8.2.5 Position indication

Remotely operated tree connector and/or tubing head connectors shall be equipped with an external position indicator suitable for observation by diver/ROV.

#### 7.8.2.6 Self-locking requirement

Hydraulic tree and tubing-head connectors shall be designed to prevent release due to loss of hydraulic locking pressure. This may be achieved by the connector self-locking mechanism (such as a flat-to-flat locking segment design) or backed up using a mechanical locking device or other demonstrated means. The design

of mechanical locking devices shall consider release in the event of malfunction. The connector and mechanical locking device design shall ensure that locking is effective with worst-case dimensional tolerances of the locking mechanism.

#### 7.8.2.7 Overlay of seal surfaces

Seal surfaces for tree and tubing-head connectors that engage metal-to-metal seals shall be inlaid with corrosion-resistant material that is compatible with well fluids, seawater, etc. Overlays are not required if the base metal is compatible with well fluids, seawater, etc., e.g. if the material is a CRA. Design is in accordance with the manufacturer's specifications.

#### 7.8.2.8 Seals testing

Means shall be provided for testing all primary seals in the connector cavity to the rated working pressure of the tree/spool connector or tubing hanger, whichever is lower.

#### 7.8.2.9 Seal replacement

The design shall allow for easy and safe replacement of the primary seal and stab subs.

#### 7.8.2.10 Hydraulic lock

The design shall ensure that trapped fluid does not interfere with the installation of the connector.

#### 7.8.2.11 Materials

Materials shall conform to 5.2.

For forged material used for pressure-containing and high-load-bearing parts, forging practices, heat treatment and test coupon (QTC or prolongation) requirements should meet those of API RP 6HT. In addition, the test coupon shall accompany the material it qualifies through all thermal processing, excluding stress relief.

### 7.8.3 Testing

#### 7.8.3.1 General

The test procedure in 7.8.3.2 applies to both mechanical and hydraulic connectors.

#### 7.8.3.2 Factory acceptance testing

After final assembly, the connector shall be tested for proper operation and interface in accordance with the manufacturer's written specification using actual mating equipment or an appropriate test fixture. Functional testing shall be conducted in accordance with the manufacturer's written specification to verify the primary and secondary operating and release mechanisms, override mechanisms and locking mechanisms. Testing shall verify that the actual operating forces/pressures fall within the manufacturer's documented specifications.

Connectors that are hydraulically operated shall have its internal hydraulic circuit, piston(s), and cylinder cavity(s) subjected to a hydrostatic test to demonstrate structural integrity. The test pressure shall be a minimum of 1,5 times the hydraulic RWP of the connector. No visible leakage shall be allowed. Minimum hold period for the connector's hydraulic actuator hydrostatic test is 3 min.

## 7.9 Tree stab/seal subs for vertical tree

### 7.9.1 General

Stab subs and seal subs provide pressure-containing or pressure-controlling conduits between two remotely mated subsea components within the tree/tubing head envelope (valve block to tubing hanger, for example). Stab/seal subs are used on the production (injection) bore, annulus bore, hydraulic couplers, SCSSV control lines and downhole chemical-injection lines. The housing for electrical penetrator(s) shall also be treated as a stab sub with respect to the design requirements in 7.9. Stab/seal subs shall be considered pressure-containing if their failure to seal as intended results in a release of wellbore fluid to the environment. Stab/seal subs shall be considered pressure-controlling if at least one additional seal barrier exists between the stab/seal sub and the environment.

Stab subs and seal subs in the production and annulus bore should conform to standard maximum pressure ratings of 34,5 MPa (5 000 psi), 69 MPa (10 000 psi) or 103,5 MPa (15 000 psi) as covered by this part of ISO 13628. The effects of pressure acting externally on stabs and seal subs shall also be considered in their design up to the tree pressure rating, pressure rating of any seal sub in the annulus envelope outside the seal stab, or the hyperbaric pressure rating, whichever is greatest. Stab subs or seal subs used to conduct SCSSV control fluid or injected chemicals shall be rated to a working pressure equal to or greater than the SCSSV control pressure or injection pressure, respectively, whichever is the higher, and be limited to 17,2 MPa (2 500 psi) plus the RWP of the tree. Proof testing shall be at 1,0 times the stab/seal sub pressure rating if the stab/seal sub is pressure-controlling, and 1,5 times the stab/seal sub pressure rating if the stab/seal sub is pressure-containing. Working-pressure tests shall be at the pressure rating of the seal sub and its fluid passage. Galleries outboard the stab/seal sub shall be tested to the highest pressure rated stab/seal sub in that gallery, unless a means to vent the gallery is provided, in which case the gallery test shall be at the working pressure rating of the interface.

### 7.9.2 Design

#### 7.9.2.1 Loads/conditions

As a minimum, the following loading parameters/conditions shall be considered and documented by the manufacturer when designing the stab subs/seal subs:

- internal and external pressure;
- separation loads;
- bending loads during installation;
- thermal expansion;
- corrosion;
- galling.

#### 7.9.2.2 Seal design

The seal mechanism may be either a metal-to-metal or a redundant non-metallic seal. The design should consider ease and safety of seal replacement. Corrosion-resistant material shall be used for the metal-to-metal seal-sub designs and is recommended for redundant non-metallic seal designs.

#### 7.9.2.3 Exclusion of debris

The design should consider the effect or the exclusion of debris at the stab/seal sub interface.

## 7.10 Valves, valve blocks and actuators

### 7.10.1 Overview

#### 7.10.1.1 General

In 7.10 are covered subsea valves, valve blocks and actuators used on subsea trees. It provides information with respect to design performance standards.

#### 7.10.1.2 Flanged end valves

Valves having ISO-type flanged end connections shall use integral, studded, or welding neck, flanges as specified in 7.1.

For units having end and outlet connections with different pressure ratings, the rating of the lowest-rated pressure-containing part shall be the rating of the unit.

#### 7.10.1.3 Other end connector valves

Clamp-type connections shall conform to ISO 13533. OECs shall conform to 7.4.

NOTE For the purposes of this provision, API Spec 16A is equivalent to ISO 13533 (all parts).

### 7.10.2 Design

#### 7.10.2.1 Valves and valve blocks

##### 7.10.2.1.1 General

Valves and valve blocks used in the subsea tree bores and tree piping shall conform to the applicable bore dimensional requirements of ISO 10423. Other valve and valve block dimensions shall be in accordance with 7.1 through 7.6.

If the lower end connection of the tree that mates to the tree connector encapsulates SCSSV control lines that have a higher pressure rating than the tree-pressure rating, the design shall consider the effect of a leaking control line or seal sub unless relief is provided as described in 5.1.2.1.1. Proof testing of the end connections and body shall be at 1,5 times RWP.

For valves and valve blocks used in TFL applications, the design shall also comply with ISO 13628-3 for TFL pumpdown systems.

Consideration should be given to the inclusion of diver/ROV valve overrides, particularly in the vertical run, to facilitate well intervention in the event of hydraulic control failure.

Re-packing/greasing facilities, if incorporated, shall meet the requirements of 7.3.

##### 7.10.2.1.2 Valves

The following apply to all valve types.

- a) Valves shall have their service classification as identified in Clause 5, with respect to pressure rating, temperature and material class. Additionally, underwater safety valves (USVs) shall be rated for sandy service (PR2 class II), as defined by ISO 10423.
- b) Valves for subsea service shall be designed considering the effects of external hydrostatic pressure and the environment as well as internal fluid conditions.
- c) Manufacturers of subsea valves shall document design and operating parameters of the valves as listed in Table 16.

- d) Measures shall be taken to ensure that there are no burrs or upsets at the gate and seat bores that can damage the gate and seat surfaces or interfere with the passage of wireline or TFL tools.

**Table 16 — Design and operating parameters of valves and actuators**

<b>A</b>	<b>Valve</b>
1	Nominal bore size
2	Working pressure
3	Class of service
4	Temperature classifications
5	Type and size connections
6	Valve stroke
7	Overall external dimensions and mass
8	Materials class rating
9	Failed position (open, closed, in place) <sup>a</sup>
10	Unidirectional or bi-directional
11	Position indicator type (visual, electrical, etc.)
<b>B</b>	<b>Actuator</b>
1	Minimum hydraulic operating pressure
2	Maximum hydraulic operating pressure
3	Temperature classifications
4	Actuator volume displacement
5	Number of turns to open/close valve <sup>b</sup>
6	Override force or torque required <sup>b</sup>
7	Maximum override force or torque <sup>b</sup>
8	Maximum override speed <sup>b</sup>
9	Overall external dimensions and mass
10	Override type and class (in accordance with ISO 13628-8) <sup>b</sup>
11	Make and model number of valves the actuator is designed for
<b>C</b>	<b>Valve/hydraulic actuator assembly</b>
1	Maximum water depth rating
At maximum rated depth of assembly and maximum rated bore pressure, the actuator hydraulic pressure in MPa (psi) at the following valve positions:	
2	Start to open from previously closed position
3	Fully open
4	Start to close from previously open position
5	Fully closed
At maximum rated depth of assembly and 0 MPa (psi), bore pressure, the actuator hydraulic pressure, expressed in megapascals (pounds per square inch) in at the following valve positions:	
6	Start to open from previously closed position
7	Fully open
8	Start to close from previously open position
9	Fully closed
<sup>a</sup>	Where applicable.
<sup>b</sup>	If equipped with manual or ROV override.



### 7.10.2.1.3 Valve blocks

Valve blocks shall meet the design requirements given in 6.1 and in ISO 10423.

Dual bore valve blocks shall meet the applicable design requirements of ISO 10423. Table 17 specifies the centre distances for dual parallel bore valve blocks designed to this part of ISO 13628. There are no specific end-to-end dimension or outlet requirements for these valve blocks.

Other multiple bore valve block configurations shall meet the applicable design requirements of ISO 10423.

**Table 17 — Centre distances of conduit bores for dual parallel bore valve blocks**

Valve size mm (in)	Valve-bore centre to valve-bore centre mm (in)	Large valve-bore centre to block-body centre mm (in)
<b>34,5 MPa (5 000 psi)</b>		
52 × 52 (2-1/16 × 2-1/16)	90,09 (3,547)	45,06 (1,774)
65 × 52 (2-9/16 × 2-1/16)	90,09 (3,547)	41,91 (1,650)
79 × 52 (3-1/8 × 2-1/16)	116,28 (4,578)	51,00 (2,008)
103 × 52 (4-1/16 × 2-1/16)	115,90 (4,563)	44,45 (1,750)
130 × 52 (5-1/8 × 2-1/16)	114,30 (4,500)	0,0
<b>69,0 MPa (10 000 psi)</b>		
52 × 52 (2-1/16 × 2-1/16)	90,17 (3,550)	45,05 (1,774)
65 × 52 (2-9/16 × 2-1/16)	101,60 (4,000)	47,63 (1,875)
78 × 52 (3-1/16 × 2-1/16)	128,27 (5,050)	64,10 (2,524)
103 × 52 (4-1/16 × 2-1/16)	127,00 (5,000)	41,28 (1,625)
130 × 52 (5-1/8 × 2-1/16)	146,05 (5,750)	0,0
<b>103,5 MPa (15 000 psi)</b>		
52 × 52 (2-1/16 × 2-1/16)	90,17 (3,550)	45,05 (1,774)
65 × 52 (2-9/16 × 2-1/16)	101,60 (4,000)	47,63 (1,875)
78 × 52 (3-1/16 × 2-1/16)	128,27 (5,050)	64,10 (2,524)
103 × 52 (4-1/16 × 2-1/16)	139,70 (5,500)	28,58 (1,125)
130 × 52 (5-1/8 × 2-1/16)	171,45 (6,750)	0,0

Bore-position seal-preparation centers shall be within 0,13 mm (0,005 in) of their true position with respect to the block-body center or block-body end connection seal. Bores shall be true within 0,25 mm (0,010 in) total indicator reading with respect to the centers of the bore seal preparation.

### 7.10.2.1.4 Materials

Materials shall conform to 5.2. Seal surfaces that engage metal-to-metal seals for pressure-controlling seals shall be inlaid or appropriately coated with a corrosion-resistant material that is compatible with well fluids, seawater, etc. Overlays or coatings are not required if the base material is compatible with well fluids, seawater, etc. See 7.1.2.5.5 for pressure-containing-seal surface-treatment requirements.

For forged material used for pressure-containing and high-load-bearing parts, forging practices, heat treatment and test coupon (QTC or prolongation) requirements should meet those of API RP 6HT. In addition, the test coupon shall accompany the material it qualifies through all thermal processing, excluding stress relief.

### 7.10.2.2 Actuators

#### 7.10.2.2.1 Equipment covered

In 7.10.2.2 are addressed mechanical and hydraulic actuators.

#### 7.10.2.2.2 General

The following requirements apply to the design of subsea valve actuators.

- a) Design shall consider marine growth, fouling, corrosion, hydraulic operating fluid and, if exposed, the well stream fluid.
- b) Subsea actuator opening and closing force shall be sufficient to operate the subsea valve when the valve is at the most severe design operating conditions without exceeding 90 % of the hydraulic operating pressure as defined in 7.10.2.2.2 c). This requirement is intended to ensure that the actuator is adequately designed to operate with the hydraulic power source at FAT and SIT without the pressure (ambient external and hydraulic pressure head) associated with water depth.
- c) Subsea actuators covered by this part of ISO 13628 shall be designed by the manufacturer to meet the hydraulic control pressure rating in accordance with the manufacturer's specification.
- d) In addition to the requirement in 7.10.2.2.2 c), the subsea actuator shall be designed to control the subsea valve when the valve is at its most severe design condition and at the hydraulic pressure(s) associated with the most severe intended operating sequence of the valve(s) that are connected to a common supply umbilical. This implies that the actuator shall be able to ensure that fail-closed (or fail-open or fail-in-place) valves retain their fail (reset) position, and can subsequently respond to a command to move the valve to its actuated position, over the range of hydraulic supply pressure created by a severe operating sequence due to extremely long offsets (between the hydraulic supply source and the actuator), accumulator supply drawdown or multiple valve/function operations, etc.

#### 7.10.2.2.3 Manual actuators

The following requirements apply to manual actuators.

- a) The design of the manual actuation mechanism shall take into consideration the ability of divers, ADSs and/or ROVs, for operations. Manual valves shall be operable by divers and/or ROVs. The valve shall be protected from over-torquing.
- b) Manufacturers of manual actuators or overrides for subsea valves shall document maintenance requirements, number of turns to open, operating torque, maximum allowable torque or appropriate linear force to actuate.
- c) Valves shall be turned in the counter-clockwise direction to open and the clockwise direction to close as viewed from the end of the stem for fail-close valves.
- d) Intervention fixtures for manual valve actuators shall comply with the requirements of 13628-8 or ISO 13628-9, as appropriate for the intended use.

#### 7.10.2.2.4 Hydraulic actuators

The following requirements apply to hydraulic actuators.

- a) Hydraulic actuators shall be designed for a specific valve or specific group of valves.
- b) Hydraulic actuators shall have porting to facilitate flushing of the hydraulic cylinder.

- c) Hydraulic actuators shall be designed to operate without damage to the valve or actuator (to such an extent that prevents meeting any other performance requirement), when hydraulic actuation pressure (within its rated working pressure) is either applied or vented under any valve bore pressure conditions or stoppage of the valve bore sealing mechanism at any intermediate position.
- d) The design of the actuator shall consider the effects of external hydrostatic pressure at the manufacturer's maximum rated water depth and the RWP of the valve.
- e) Manual overrides, if provided, shall be in accordance with the following requirements.
  - A rotation-type override shall open the valve with a counter-clockwise rotation as viewed from the end of the stem on fail closed valves.
  - A push-pull-type override for fail-closed valve shall open the valve with a push on the override.
- f) For fail-open valves, the manufacturers shall document the method and procedures for override.
- g) Position indicators shall be incorporated on all actuators unless otherwise agreed with purchaser. They shall clearly show valve position (open/close and full travel) for observation by diver/ROV. Where the actuator incorporates ROV override, consideration should be given to visibility of the position indicator from the working ROV.
- h) The actuator fail-safe mechanism shall be designed and verified to provide a minimum mean spring life of 5 000 cycles.
- i) Actuator manufacturer shall document design and operating parameters, as listed in Table 16.

### 7.10.2.3 Valve/hydraulic actuator assembly

#### 7.10.2.3.1 Closing/opening force

The subsea valve and hydraulic actuator assembly design shall utilize valve bore pressure and/or spring force to assist closing of the fail-to-close position valve (or opening for a fail-to-open position valve).

#### 7.10.2.3.2 Actuator protection from wellbore pressure

Means shall be provided to prevent overpressuring of the actuator piston and compensation chambers, in the event that well bore pressure leaks into the actuator.

#### 7.10.2.3.3 Water depth rating

Manufacturer shall specify the maximum water depth rating of the valve/actuator assembly. Subsea valve and actuator assemblies designated as fail-closed (open) shall be designed and fabricated to be capable of fully closing (opening) the valve at the maximum rated water depth under all of the following conditions:

- a) from 0,10 MPa absolute (14,7 psia) to maximum working pressure of the valve in the valve bore;
- b) differential pressure equal to the rated bore pressure across the valve bore sealing mechanism at the time of operation;
- c) external pressure on the valve/actuator assembly at the maximum rated water depth using seawater specific gravity of 1,03;
- d) no hydraulic assistance in the closing (opening) direction of the actuator other than hydrostatic pressure at the operating depth;
- e) for hydraulic actuators, 0,69 MPa (100 psi) plus seawater ambient hydrostatic pressure at the maximum rated depth of the assembly acting on the actuator piston in the opening (closing) direction.

Other actuator performance criteria may be specified by the manufacturer, such as wire/coiled tubing shearing design criteria, but these shall be considered separately from the above fundamental set of criteria.

NOTE The maximum water depth rating is calculated using the above set of "extreme worst case" conditions for the purpose of standard reference, but does not necessarily represent operating limitation. Additional information relating to operating water depth for specific applications can be provided and agreed between manufacturer and user as being more representative of likely field conditions.

### 7.10.3 Materials

Materials shall conform to 5.2. Seal surfaces that engage metal-to-metal seals shall be inlaid with a corrosion-resistant material that is compatible with well fluids, seawater, etc. Overlays are not required if the base material is compatible with well fluids, seawater, etc.

For forged material used for pressure-containing and high-load-bearing parts, forging practices, heat treatment and test coupon (QTC or prolongation) requirements should meet those of API RP 6HT. In addition, the test coupon shall accompany the material it qualifies through all thermal processing, excluding stress relief.

### 7.10.4 Testing

#### 7.10.4.1 Validation testing

##### 7.10.4.1.1 General

Validation testing is required to qualify specific valve and valve actuator designs manufactured under this part of ISO 13628 (see 5.1.7).

##### 7.10.4.1.2 Sandy service

Sandy-service underwater safety valves shall be tested in accordance with ISO 10423, in addition to tests as specified in Clause 5.

##### 7.10.4.1.3 Valve and actuator assembly testing

Subsea valve and actuator assemblies shall be tested to demonstrate the performance limits of the assembly. Unidirectional valves shall be tested with pressure applied in the intended direction. Bi-directional valves shall be tested with pressure applied in both directions in separate tests.

For a fail-closed (fail-open) valve, with the assembly subjected to external hydrostatic pressure (actual or simulated) of the maximum rated water depth and full rated bore pressure, applied as a differential across the gate, it shall be shown that the valve opens (closes) fully from a previously closed (open) position with a maximum of 90 % of the hydraulic RWP above actual or simulated ambient pressure, or the minimum hydraulic pressure as defined in 7.10.2.2, applied to the actuator.

For a hydraulic fail-closed (fail-open) valve, with the assembly subjected to the external hydrostatic pressure, (actual or simulated) of the maximum rated water depth and atmospheric pressure in the body cavity, the valve shall be shown to move from a previously fully open (closed) position to a fully closed (open) position as the hydraulic pressure in the actuator is lowered to a minimum of 0,69 MPa (100 psi) above ambient pressure.

For a fail-in-place valve, with the assembly subjected to the external hydrostatic pressure (actual or simulated) of the maximum rated water depth, the valve shall be shown to close or open fully from a previously open or closed position with a maximum of 90 % of the operating hydraulic fluid pressure above actual or simulated ambient pressure, or the minimum hydraulic pressure as defined in 7.10.2.2.2, applied to the actuator. A fail-in-place hydraulic valve shall remain in position as the hydraulic pressure in the actuator is lowered to a minimum of 0,69 MPa (100 psi) above ambient pressure.

#### 7.10.4.2 Factory acceptance testing

##### 7.10.4.2.1 General

Each subsea valve and valve actuator shall be subjected to a hydrostatic and operational test to demonstrate the structural integrity and proper assembly and operation of each completed valve and/or actuator. Tables 18 and 19 offer examples of test documentation.

##### 7.10.4.2.2 Subsea valve

Each subsea valve shall be factory acceptance tested in accordance with PSL 2 or PSL 3 or PSL 3G as specified in 5.4.5 or 5.4.6.

STANDARDSISO.COM : Click to view the full PDF of ISO 13628-4:2010

Table 18a — Example of PSL 2 valve factory acceptance test documentation

VALVE SHELL PRESSURE TEST						
	HYDROSTATIC TEST			GAS TEST		
	PSI	Start Time	End Time	PSI	Start Time	End Time
1. Primary Body Test (TP) 3 min hold				NA	NA	NA
2. Secondary Body Test (TP) 3 min hold				NA	NA	NA
VALVE SEAT PRESSURE TEST						
	HYDROSTATIC TEST			GAS TEST		
	PSI	Start Time	End Time	PSI	Start Time	End Time
3. Drift Test	Successfully Completed Yes/No (As applicable)					
4. Seat Test (RWP) 3 min hold				NA	NA	NA
5. First hydrostatic break open seat		NA	NA	NA	NA	NA
6. Seat Test (RWP) 3 min hold (PSL 2)				NA	NA	NA
7. Second hydrostatic break open seat		NA	NA	NA	NA	NA
8. Seat Test (WP) 3 min hold (PSL 2)				NA	NA	NA
9. <sup>a</sup> Opposite Seat Test (RWP) 3 min hold				NA	NA	NA
10. <sup>a</sup> First hydrostatic break open opposite seat		NA	NA	NA	NA	NA
11. <sup>a</sup> Opposite Seat Test (RWP) 3 min hold				NA	NA	NA
12. <sup>a</sup> Second hydrostatic break open opposite seat		NA	NA	NA	NA	NA
13. <sup>a</sup> Opposite Seat Test (LP) 3 min hold				NA	NA	NA
<sup>a</sup> Bi-directional sealing valves only. TP = test pressure = 1,5 x Rated working pressure (RWP), LP = low pressure = 0,2 x Rated working pressure (RWP).						

Table 18b — Example of PSL 3 valve factory acceptance test documentation

VALVE SHELL PRESSURE TEST						
	HYDROSTATIC TEST			GAS TEST		
	PSI	Start Time	End Time	PSI	Start Time	End Time
1. Primary Body Test (TP) 3 min hold				NA	NA	NA
2. Second. Body Test (TP) 15 min hold (PSL 3)				NA	NA	NA
VALVE SHELL PRESSURE TEST						
	HYDROSTATIC TEST			GAS TEST		
	PSI	Start Time	End Time	PSI	Start Time	End Time
3. Drift Test	Successfully Completed Yes/No (As applicable)					
4. Seat Test (RWP) 3 min hold				NA	NA	NA
5. First hydrostatic break open seat		NA	NA	NA	NA	NA
6. Seat Test (RWP) 15 min hold (PSL 3)				NA	NA	NA
7. Second hydrostatic break open seat		NA	NA	NA	NA	NA
8. Seat Test (LP) 15 min hold				NA	NA	NA
9. <sup>a</sup> Opposite Seat Test (RWP) 3 min hold				NA	NA	NA
10. <sup>a</sup> First hydrostatic break open opposite seat		NA	NA	NA	NA	NA
11. <sup>a</sup> Opposite Seat Test (RWP) 15 min hold				NA	NA	NA
12. <sup>a</sup> First hydrostatic break open opposite seat		NA	NA	NA	NA	NA
13. <sup>a</sup> Opposite Seat Test (LP) 15 min hold				NA	NA	NA
<sup>a</sup> Bi-directional sealing valves only. TP = test pressure = 1,5 x Rated working pressure (RWP), LP = low pressure = 0,2 x Rated working pressure (RWP).						

Table 18c — Example of PSL 3G valve factory acceptance test documentation

VALVE SHELL PRESSURE TEST						
	HYDROSTATIC TEST			GAS TEST		
	PSI	Start Time	End Time	PSI	Start Time	End Time
1. Primary Body Test (TP) 3 min hold				NA	NA	NA
2. Second. Body Test (TP) 15 min hold (PSL 3G)				NA	NA	NA
3. Third Body Test (RWP) 15 min hold (PSL 3G)	NA	NA	NA			
VALVE SHELL PRESSURE TEST						
	HYDROSTATIC TEST			GAS TEST		
	PSI	Start Time	End Time	PSI	Start Time	End Time
4. Drift Test	Successfully Completed Yes/No (As applicable)					
5. Seat Test (RWP) 3 min hold				NA	NA	NA
6. First hydrostatic break open seat (RWP)		NA	NA	NA	NA	NA
7. Seat test (RWP) 15 min hold				NA	NA	NA
8. Second hydrostatic break open seat (RWP)		NA	NA	NA	NA	NA
9. Seat Test (LP) 15 min hold				NA	NA	NA
10. <sup>a</sup> Opposite Seat Test (RWP) 3 min hold				NA	NA	NA
11. <sup>a</sup> First hydrostatic break open opposite seat (RWP)		NA	NA	NA	NA	NA
12. <sup>a</sup> Opposite Seat Test (RWP) 15 min hold				NA	NA	NA
13. <sup>a</sup> Second hydrostatic break open opposite seat (RWP)		NA	NA	NA	NA	NA
14. <sup>a</sup> Opposite Seat Test (LP) 15 min hold				NA	NA	NA
15. Seat gas test (RWP) 15 min hold	NA	NA	NA			
16. <sup>a</sup> Opposite Seat Gas Test (RWP) 15 min hold	NA	NA	NA			
<sup>a</sup> Bi-directional sealing valves only TP = test pressure = 1,5 x Rated working pressure (RWP), LP = low pressure = 0,2 x Rated working pressure (RWP).						



#### 7.10.4.2.3 Subsea valve actuator

The following are tests for the subsea valve actuator.

a) Hydraulic actuator hydrostatic shell test:

Each hydraulic actuator cylinder and piston shall be subjected to a hydrostatic test to demonstrate structural integrity. The test pressure shall be a minimum of 1,5 times the hydraulic RWP of the actuator. No visible leakage shall be allowed.

Minimum hold period for actuator hydrostatic test is 3 min.

b) Actuator operational test:

The actuator shall be tested for proper operation by stroking the actuator from the fully closed position to the fully open position, a minimum of three times. The actuator shall operate smoothly in both directions in accordance with the manufacturer's written specification. Test media for hydraulic actuators shall be specified by the manufacturer. Cycling prior to further testing followed by low pressure testing in the next step confirms that the seals were not damaged by the high-pressure test.

c) Hydraulic actuator seal test:

The actuator seals shall be pressure-tested in two steps by applying pressures of 0,2 times the hydraulic RWP and a minimum of 1,0 times the hydraulic RWP of the actuator. No seal leakage shall be allowed. The test media shall be specified by the manufacturer. The minimum test duration for each test pressure shall be 3 min. The test period shall not begin until the test pressure has been reached and has stabilized. The test gauge pressure reading and time at the beginning and at the end of each pressure holding period shall be recorded. The low-pressure test is not applicable to flow-by-type actuators.

d) Hydraulic actuator compensation circuit test:

The actuator compensation chamber shall be tested per the manufacturer's written specification.

**Table 19 — Example documentation of the factory acceptance testing for an hydraulic actuator**  
[\(Click here to access an electronic revisable version of this form.\)](#)

Factory acceptance test form for an hydraulic actuator				
Test sequence (3 min minimum hold period)		Hydrostatic test		
		Pressure	Start time	End time
1	Control port hydrostatic test (1,5 times hydraulic RWP)			
2	Control port hydrostatic test (1,5 times hydraulic RWP)			
3	Control port seal test (0,2 times hydraulic RWP)			
4	Control port seal test (1,0 times hydraulic RWP)			
5	Compensation port hydrostatic test (1,5 times compensation working pressure)			
6	Spring chamber hydrostatic test (1,5 times compensation working pressure)			
7	Actuator functional test: Complete three cycles			
8	Manual operation test: Complete three cycles (rotary design) one cycle (linear design)	Stroke, expressed as millimetres (inches) per number of turns to operate	Force per torque, expressed as newtons (pounds) per newton-(foot-pounds) with no pressure	Force per torque, expressed as newtons (pounds) per newton-(foot-pounds) with differential pressure

**7.10.4.2.4 Testing of valve/actuator assembly**

After final assembly, each valve/actuator assembly (including override if fitted) shall be subjected to a functional and pressure test to demonstrate proper assembly and operation in accordance with the manufacturer’s written specification. Equipment assembled entirely with previously hydrostatically tested equipment need only be tested to rated working pressure. The functional test shall be performed by a qualified subsea valve/actuator manufacturer. All test data shall be recorded on a data sheet and shall be maintained by the subsea valve/actuator manufacturer for at least five years after date of manufacture. The test data sheet shall be signed and dated by the person(s) performing the functional test(s).

The subsea valve and actuator assembly shall meet the testing requirement of 7.10.4.2.2 and 7.10.4.2.4.

**7.10.5 Marking**

**7.10.5.1 Subsea valve marking**

The valve portion of subsea valve equipment shall be marked as shown in Table 20. The manufacturer may arrange required nameplate markings as suitable to fit available nameplate space.

Table 20 — Marking for subsea valves

Marking		Application
1	Manufacturer's name or trademark	Body (if accessible) and nameplate
2	ISO 13628-4	Nameplate
3	RWP	Body (if accessible), bonnet and nameplate
4	PSL	Nameplate
5	Subsea valve size and, when applicable, the restricted or oversized bore	Body or nameplate or both at manufacturer's option
6	Direction of flow, if applicable	Body or nearest accessible location
7	Serial or identification number unique to the particular subsea valve	Nameplate and body if accessible

#### 7.10.5.2 Subsea valve actuator marking

The subsea valve actuator shall be marked as shown in Table 21.

Table 21 — Marking for subsea valve actuator

Marking		Application
1	Manufacturer's name or trademark	Nameplate and cylinder
2	ISO 13628-4	Nameplate
3	Maximum working pressure of the cylinder	Nameplate
4	Manufacturer's part number	Nameplate
5	Serial or identification number	Nameplate and cylinder

#### 7.10.5.3 Subsea valve and actuator assembly marking

The subsea valve and actuator assembly shall be marked as shown in Table 22.

Table 22 — Marking for subsea valve and actuator assembly

Marking		Application
1	Assembler's name or trademark	Nameplate
2	ISO 13628-4	Nameplate
3	Assembly serial or identification number	Nameplate
4	Maximum water depth rating	Nameplate

#### 7.10.5.4 Nameplates

Nameplates shall be attached after final coating of the equipment. Nameplates should be designed to remain legible for the design life of the valve/actuator.

#### 7.10.5.5 Low-stress marking

All marking done directly on pressure-containing components, excluding peripheral marking on API flanges, shall be done using low-stress marking methods.

### 7.10.5.6 Flow direction

All subsea valves that are designed to have unidirectional flow should have the flow direction prominently and permanently marked.

## 7.11 TFL wye spool and diverter

### 7.11.1 General

The TFL wye spool is located between the master valves and the swab closure. The purpose of the wye spool is to provide a smooth transitional passageway for TFL tools from the flowline(s) to the vertical production bore(s) of the well, while still permitting normal wireline or other types of vertical access through the tree top. See ISO 13628-3 for TFL pump-down systems for further information.

### 7.11.2 Design

#### 7.11.2.1 Wye spool

All transitional surfaces through the wye spool shall have chamfered surfaces without a reduced diameter or large gaps in accordance with the dimensional requirements of ISO 13628-3 for TFL pump-down systems.

The intersection of the flowloop bore with the vertical wellbore shall comply with the dimensional requirements of ISO 13628-3 for TFL pump-down systems.

#### 7.11.2.2 Diverter

Provisions shall be made to divert TFL tools to and from the TFL loops in accordance with the manufacturer's written specification. Diverter device(s) shall be designed in accordance with ISO 13628-3 for TFL pump-down systems.

#### 7.11.2.3 Materials

Materials shall conform to 5.2. Seal surfaces that engage metal-to-metal seals shall be inlaid with a corrosion-resistant material that is compatible with well fluids, seawater, etc. Overlays are not required if the base material is compatible with well fluids, seawater, etc.

For forged material used for pressure-containing and high-load-bearing parts, forging practices, heat treatment and test coupon (QTC or prolongation) requirements should meet those of API RP 6HT. In addition, the test coupon shall accompany the material it qualifies through all thermal processing, excluding stress relief.

#### 7.11.2.4 Interfaces

##### 7.11.2.4.1 General

The wye spool may be integral with either the master-valve block or swab-valve block. When non-integral, 7.11.2.4.2 to 7.11.2.4.5 shall apply.

##### 7.11.2.4.2 Master valve block interface

The wye-spool lower connection shall be sized to mate with the master-valve block upper connection. This connection shall provide pressure integrity equal to the working pressure of the subsea tree and provide a structural strength capable of withstanding the combined loads of full working pressure at the connection plus any externally applied loads.

#### 7.11.2.4.3 Swab closure interface

The upper wye spool connection shall be sized to mate with the swab-closure lower connection. The connection shall provide pressure integrity equal to the working pressure of the subsea tree and provide a structural strength capable of withstanding the combined loads of full working pressure at the connection plus any externally applied loads.

#### 7.11.2.4.4 TFL flowloop interfaces

The wye outlet connection shall be sized to mate with either the TFL flowloop piping or the wing valve. This connection shall provide pressure integrity equal to the working pressure of the tree and provide a structural strength capable of withstanding the combined loads of full working pressure at the connection plus any externally applied loads specified by the manufacturer. Combined pressure loading, piping preloads (or tension), flowloop make-up and any other applied loads shall not exceed the yield strength of the TFL piping as defined in 7.17, nor shall it reduce the flowline internal diameter to below the drift diameter. The bore of the wye spool shall be aligned with the bore of the flowloop according to the dimensional requirements of ISO 13628-3 for TFL pumpdown systems. Angles of the TFL wye spool/flowloop connection shall be less than or equal to 15° from vertical.

#### 7.11.2.4.5 WYE spool/diverter interface

The diverter bore shall be concentric with the bore of the flowline and a smooth transition surface should be used to connect the bores. In addition to the straight section of the flowloop above the transition surface, a straight section shall also be provided above or below any locking recess or side pocket. The internal surface shall provide a smooth transition from cylindrical passage to curvature of the loop.

### 7.11.3 Testing

All TFL wye spools and diverters shall be tested in accordance with 5.4 and drift-tested as specified in ISO 13628-3 for TFL pumpdown systems.

## 7.12 Re-entry interface

### 7.12.1 General

#### 7.12.1.1 Introduction

In 7.12 are addressed the upper terminations of the tree. The design and manufacture of control couplers/connectors, which might or might not be integral with the tree upper connection, are addressed in 7.20.

#### 7.12.1.2 Purpose

The purpose is to provide an uppermost attachment interface on the tree for connection of

- a tree running tool used for installation and workover purposes,
- a tree cap,
- internal crown plugs, if applicable,
- interface to LWRP or subsea drilling BOP stack, if applicable,
- interface to other intervention hardware.

### 7.12.1.3 Integral or non-integral

The tree upper connection may consist of a separate spool, which mechanically connects and seals to the tree upper valve or upper valve block termination. The upper connection may consist of an integral interface profile in or on top of the valve(s) body.

### 7.12.2 Design

#### 7.12.2.1 Pressure rating

The re-entry interface shall be rated to the tree working pressure plus an allowance for other loading effects as defined in 7.12.3.

#### 7.12.2.2 Re-entry interface upper connection/profile

The tree re-entry interface shall provide a locking and sealing profile with a design strength based on loading considerations specified in 7.12.3. Corrosion-resistant overlays shall be provided for metal sealing surfaces. Overlays are not required if the base metal is corrosion-resistant. The connection shall also provide for passage of wireline tools and shall not limit the drift diameter of the tree bore.

#### 7.12.3 Design loads/conditions

Analytical design methods shall conform to 5.1. As a minimum, the following loading parameters/conditions shall be considered and documented by the manufacturer when designing the re-entry interface:

- internal and external pressure;
- pressure separation loads, which shall be based on worst-case sealing conditions (leakage to the largest redundant seal diameter shall be assumed);
- mechanical preloads;
- riser bending and tension loads;
- external environmental loads;
- fatigue considerations;
- vibration;
- mechanical installation (impact) loads;
- hydraulic coupler thrust and/or preloads;
- corrosion.

### 7.13 Subsea tree cap

#### 7.13.1 General

##### 7.13.1.1 Introduction

Vertical and horizontal trees use internally and externally attached tree caps. When internal caps are used, an external debris cap or cover may be installed to protect sealing surfaces and hydraulic couplers. Hydraulic couplers may be incorporated in the tree cap. These may be integral with the cap or externally attached. The design and manufacture of control couplers/connectors are addressed in 7.20.2.6.

### 7.13.1.2 Non-pressure-containing tree cap

Non-pressure-containing tree caps protect the tree re-entry interface, hydraulic couplers and vertical wellbores from possible environmental damage or undesired effects resulting from corrosion, marine growth or potential mechanical loads. Design of non-pressure-containing tree caps shall comply with Clause 5 and is not addressed further in this part of ISO 13628.

### 7.13.1.3 Pressure-containing tree cap

An externally attached pressure-containing tree cap provides protection to the re-entry interface and hydraulic couplers and provides an additional sealing barrier between tree wellbore(s) and the environment. The cap may also perform the function of mating the control system hydraulic couplers. An internally attached pressure-containing tree cap provides an additional pressure barrier.

## 7.13.2 Design

### 7.13.2.1 General

The provisions in 7.13.2 apply to pressure-containing tree caps. The design of this equipment shall comply with 5.1. The requirements given in 7.13.2.2 to 7.13.2.4 are generally applicable to both internally and externally attached tree caps.

### 7.13.2.2 Pressure rating

The tree cap shall be rated to the tree working pressure as defined by 5.1.2.1.2 plus an allowance for other loading effects as defined in 7.13.2.4.

### 7.13.2.3 Tree cap locking mechanism

The tree-cap locking mechanism shall be designed to contain the rated tree working pressure acting over the corresponding seal areas that interface with the upper tree connection. The tree cap locking mechanism shall include a secondary release feature or separate fishing profile. Three types of tree cap are commonly used:

- hydraulic, remote operated;
- mechanical, remote operated;
- mechanical diver/ROV operated.

### 7.13.2.4 Design loads/conditions

Analytical design methods shall conform to 5.1. As a minimum, the following loading parameters/conditions should be considered and documented by the manufacturer when designing the tree cap:

- internal and external pressure;
- pressure separation loads, which shall be based on worst-case sealing conditions (leakage to the largest redundant seal diameter shall be assumed) unless relief is provided as described in 5.1.2.1.1;
- mechanical preloads;
- installation string bending and tension loads;
- temperature variations;
- external environmental loads;
- fatigue considerations;
- vibration;

- trapped volumes and thermal expansion;
- mechanical installation (impact) loads;
- hydraulic coupler thrust and/or preloads;
- corrosion;
- dropped objects and snag loads.

### 7.13.3 Design and functional requirements

#### 7.13.3.1 Installation pressure test

A means shall be provided to test the upper tree connection and tree-cap seal(s) after installation.

#### 7.13.3.2 Pressure venting

A means shall be provided such that any pressure underneath the tree cap can be vented prior to removal. This function may be designed either to be automatic through the running/retrieval tool or to be performed independently by diver/ROV.

#### 7.13.3.3 Hydraulic lock

A means shall be provided for the prevention of hydraulic lock during installation or removal of the tree cap.

#### 7.13.3.4 Operating pressure

Hydraulically actuated tree caps shall be capable of containing hydraulic release pressures of at least 25 % above normal operating release pressures in the event that normal operating release pressure is inadequate to effect release of the connector. The manufacturer shall document both normal and maximum operating release pressures. The unlocking force shall be greater than the locking force. The values shall be documented by the manufacturer.

#### 7.13.3.5 Secondary release

Tree caps shall be designed with a secondary release method, which may be hydraulic or mechanical. Diver/ROV/remote tooling methods should be considered. Hydraulic open and close control-line piping shall be positioned to allow cutting by diver/ROV or contain a means to vent hydraulic lock pressure if necessary for the secondary release to function.

#### 7.13.3.6 External position indication

External tree caps shall be equipped with an external position indicator to show when the tree cap is fully locked.

#### 7.13.3.7 Self-locking requirement

Hydraulic tree caps shall be designed to prevent release due to loss of hydraulic locking pressure.

This may be achieved or backed up using a mechanical locking device or other demonstrated means. The design of the locking device shall consider release in the event of a malfunction.



#### 7.13.4 Materials

Materials shall conform to 5.2. Seal surfaces that engage metal-to-metal seals shall be inlaid with a corrosion-resistant material that is compatible with well fluids, seawater, etc. Overlays are not required if the base material is compatible with well fluids, seawater, etc.

For forged material used for pressure-containing and high-load-bearing parts, forging practices, heat treatment and test coupon (QTC or prolongation) requirements should meet those of API RP 6HT. In addition, the test coupon shall accompany the material it qualifies through all thermal processing, excluding stress relief.

#### 7.13.5 Testing

##### 7.13.5.1 General

The following test procedure applies to tree caps having either mechanical or hydraulic connectors. Crown plugs, associated with HXT tubing hangers or internal tree caps, shall follow the same testing requirements as internal tree caps.

##### 7.13.5.2 Validation testing

Validation testing of the tree cap shall comply with 5.1.7. In addition, the tree cap lock down shall be tested to a minimum of 1,5 times the RWP from below and from above to 1,0 times the RWP. Where access devices (e.g. poppet, shuttle, sliding sleeve, etc.) and chemical carriers are incorporated into the design, these shall meet the design performance qualification requirements as shown in Table 4.

##### 7.13.5.3 Factory acceptance testing

Functional testing shall be conducted in accordance with the manufacturer's written specification to verify the operating and release mechanisms, override mechanisms, and locking mechanisms. Testing shall verify that the actual operating forces/pressures fall within the manufacturer's documented specifications.

Pressure-containing tree caps shall be tested in accordance with 7.8.4.2, as applicable.

#### 7.14 Tree-cap running tool

##### 7.14.1 General

A tree-cap running tool is used to install and remove subsea tree-cap assemblies. Tree-cap running tools may be mechanically or hydraulically operated.

Tools for running tree caps may have some of the following functions:

- actuation of the tree-cap connector;
- pressure tests of the tree-cap seals;
- relieve pressure beneath the tree cap;
- injection of corrosion inhibitor fluid.

##### 7.14.2 Design

###### 7.14.2.1 Operating criteria

The manufacturer shall specify the operating criteria for which the tree-cap running/retrieval tool is designed.

Tree-cap running/retrieval tools should be designed such that they function in the conditions/circumstances expected to exist during tree-cap running/retrieving operations and well re-entry/workover operations. Specific

operating criteria (design loads and angle limits, etc.) should consider the maximum surface-vessel motions and resulting maximum running string tensions and angles that can occur.

#### 7.14.2.2 Loads

As a minimum, the following loading parameters/conditions should be considered and documented by the manufacturer when designing the tree cap running tool:

- internal and external pressure;
- pressure separation loads, which shall be based on worst-case sealing conditions (leakage to the largest redundant seal diameter shall be assumed);
- mechanical preloads;
- installation string bending and tension loads;
- environmental loads;
- fatigue considerations;
- vibration;
- mechanical installation (impact) loads;
- hydraulic coupler thrust and/or preloads;
- thermal expansion (trapped fluids, dissimilar metals);
- installation/workover overpull;
- corrosion.

The manufacturer shall specify the loads/conditions for which the equipment is designed.

#### 7.14.2.3 Tree-cap to running-tool interfaces

##### 7.14.2.3.1 General

The interface between the tree cap and running tool shall be designed for release at a running string departure angle as documented by the manufacturer to meet the operational requirements. This release shall not cause any damage to the tree cap such that prevents meeting any other performance requirement nor present a risk of snagging or loosening the tree cap when removed at that angle.

The tree-cap interface consists of several main component areas:

- locking profile and connector;
- re-entry seal (where applicable);
- extension subs or seals (where applicable);
- controls and instrumentation (where applicable);
- diver/ROV interfaces (for operation and pressure testing functions).

#### 7.14.2.3.2 Locking profile and connector

The tree-cap running tool shall land and lock onto the locking profile of the tree cap and shall withstand the separating forces resulting from applied mechanical loads and when applicable the rated working pressure of the tree as specified by the manufacturer. The tree-cap running-tool connector shall meet functional requirements set forth in 7.14.2.2.

Means shall be provided to prevent trapped fluid from interfering with the make-up of the hydraulic or mechanical running-tool connector.

#### 7.14.2.3.3 Controls and instrumentation

Control system and data gathering instrumentation conduits may pass through the tree running tool body. Specific designs and selection of component materials are the responsibility of the manufacturer.

#### 7.14.2.4 Tree-guide frame interface

Guidance and orientation with other subsea equipment should conform to or be an extension of the geometries specified in 7.15.2.1, when applicable to the design.

#### 7.14.2.5 Secondary release

Hydraulically actuated tree-cap running tools shall be designed with a secondary release method that may be hydraulic or mechanical. ROV/diver/remote tooling or through-installation string should be considered. Hydraulic open and close piping shall be positioned to allow cutting by diver/ROV or contain a means to vent hydraulic lock pressure if needed for the secondary release to function.

#### 7.14.2.6 Position indication

Remotely operated tree-cap running tools shall be equipped with an external position indicator suitable for observation by diver/ROV.

### 7.14.3 Testing

#### 7.14.3.1 General

The test procedure in 7.14.3.2 applies to both mechanical and hydraulic tree-cap running-tool connectors.

#### 7.14.3.2 Factory acceptance testing

Functional testing shall be conducted in accordance with the manufacturer's written specification to verify the operating and release mechanisms, override mechanisms, and locking mechanisms. Testing shall verify that the actual operating forces/pressures fall within the manufacturer's documented specifications.

Pressure-containing tree-cap running tools shall be tested in accordance with 7.8.4.2, as applicable.

## 7.15 Tree-guide frame

### 7.15.1 General

The tree-guide frame interfaces with either a CGB or PGB (or GRA) to guide the subsea tree onto the subsea wellhead or tubing head. The frame may also provide a structural mounting for piping, flowline connection, control interfaces, work platforms, anodes, handling points, ROV docking/override panels and structural protection both on surface and subsea for tree components. The tree-guide frame provides an envelope and structural mounting for the control pod, when used. The envelope shall allow sufficient space for control-pod installation, retrieval and access. The provisions in this subclause also apply if a retrievable choke module is located on the subsea tree. The design should consider protection of actuators and critical components from

dropped objects, trawl boards, etc. when applicable. Design and associated load testing shall conform to the requirements in 5.1.3.6.

The tree-guidebase should have a guidance structure that interfaces with the CGB or posts from the PGB (GRA), to provide initial orientation and alignment. It shall be designed to provide alignment to protect seals, control line stabs and seal surfaces from damage in accordance with the manufacturer's written specification.

## 7.15.2 Design

### 7.15.2.1 Guidance and orientation

For guideline configurations, interfacing shall conform to the dimensions shown in Figure 9 a), unless the orientation system requires tighter tolerances. Guide-post funnels are typically fabricated from 273 mm OD × 13 mm wall (10 3/4 in OD × 0,5 in wall) pipe or tubulars. Spatial orientation (heading (yaw) and vertical tilt (pitch-sway) and fixed X-Y-Z position) tolerance is typically  $\pm 0,5^\circ$  when mated with the guide posts. Where guidance and orientation is dependent on guide posts, alternative means of orienting the tree running tool during surface installation/testing shall be considered to prevent damage to seal bores during installation.

For guidelineless configurations, a re-entry funnel may surround the wellhead or tubing head looking upward (funnel-up) or may be configured in concert with matching funnel equipment on the tree connector and subsequently landed over the wellhead/tubing head (funnel down). Funnel geometry usually involves one (or more) diagonal cone(s) and a centre cylinder frame to provide alignment between mating components/structures. The outermost diameter of the diagonal cone should be no less than 1,5 times the diameter of the component it is capturing. The diagonal cone's angle should be no shallower than  $40^\circ$  with respect to horizontal. Typically the cone angle is  $45^\circ$ . Once captured, the cone(s) and inner cylinder should be designed to allow for equipment re-entry at tilt angles up to  $3^\circ$  (from vertical) in any orientation, and subsequently assist in righting the captured component to vertical.

Portions of the re-entry cone may be scalloped out to accommodate the guidelineless re-entry of adjacent equipment whose capture funnel can intersect with the main funnel(s) because of space constraints. This is acceptable, although it takes away from the re-entry properties of the funnel in the scalloped-out area. Its practice should be carried out with sound engineering judgement comparing operational limits lost versus size and mass (weight) gained. Ideally, scalloped funnels should be minimized or covered wherever practical.

Since funnel-up re-entry designs are typically cylindrical and conical in nature, horizontal resting pads or a beam structure should be incorporated in the frame's design to provide a sound, flat surface that can firmly sit on spider beams to support or suspend the equipment.

When spatial orientation is required, funnel-up funnels and capture equipment may also feature Y-slots and orienting pins. The upper portion of the Y-slot should be wide enough to capture mating pins within  $\pm 7,5^\circ$  of true orientation. The Y-slot should then taper down to a width commensurate with the pin to provide orientation to within  $\pm 0,5^\circ$  (similar to the angular orientation provided by guide posts and funnels). Typically, there are two or four orienting pins, each with a minimum diameter of 101,6 mm (4,0 in) in diameter [Figure 9 b)]. Other orientation methods, such as orienting helixes or indexing devices (ratchets, etc.) are also acceptable. Whatever the orienting method, it is necessary that the design allow for the  $3^\circ$  tilt re-entry requirement with enough play to accommodate this gimbaling effect unimpeded.

Funnel-down orientation methods include helixes, indexing devices or circumferential alignment pins/posts. Orientation should initially allow a wide enough capture within  $\pm 7,5^\circ$  of true orientation, then refine the alignment down to an orientation to within  $\pm 0,5^\circ$ . Whatever the orienting method, it is necessary that the design allow for the  $3^\circ$  tilt re-entry requirement with enough play to accommodate this gimbaling effect unimpeded.

Handling lugs should be provided on the guide frame to allow handling of the assembled tree.

### 7.15.2.2 Handling

Lifting pad eyes may be provided on the guide frame to allow handling of the assembled tree complete with test skid in accordance with 5.1.3.8, 5.4.4 and 5.5.2. Lifting lugs may also be provided for tag lines. Alternatively, other safe means for handling the tree may be provided.

### 7.15.2.3 Loads

The guide funnels should be capable of supporting the full weight of the stacked tree, running tool and EDP, or alternatively landing pads may be provided. Depending on the environment in which the tree is being used, the structure may be required to extend from the bottom of the tree to the top of the tree to provide protection from installation loads and snag loads. As a minimum, the following loads, where appropriate, shall be considered and documented by the manufacturer when designing the tree guide frame:

- guideline tension;
- flowline reaction loads;
- snag loads;
- dropped object loads;
- impact loads;
- installation loads and intervention loads;
- piping and connection loads (due to frame deflection);
- handling and shipping loads.

### 7.15.2.4 Intervention interfaces

Provision for all ROV intervention to relevant ROV functions shall be provided. Subsea intervention fixtures attached to the tree-guide frame shall be in accordance with ISO 13628-8. The frame design shall not impede access or observation, as appropriate, by divers/ROV of tree functions and position indicators.

### 7.15.3 Testing

Interface testing for guideline systems shall be conducted on the guide frame by installing the frame on a four-post, 1,829 m (6,0 ft) radius test stump, or PGB in compliance with this part of ISO 13628. A wellhead connector and mandrel or other centralizing means shall be used during the test. Test results shall be in accordance with the manufacturer's written specifications.

Dimensions in millimetres (inches) unless otherwise indicated

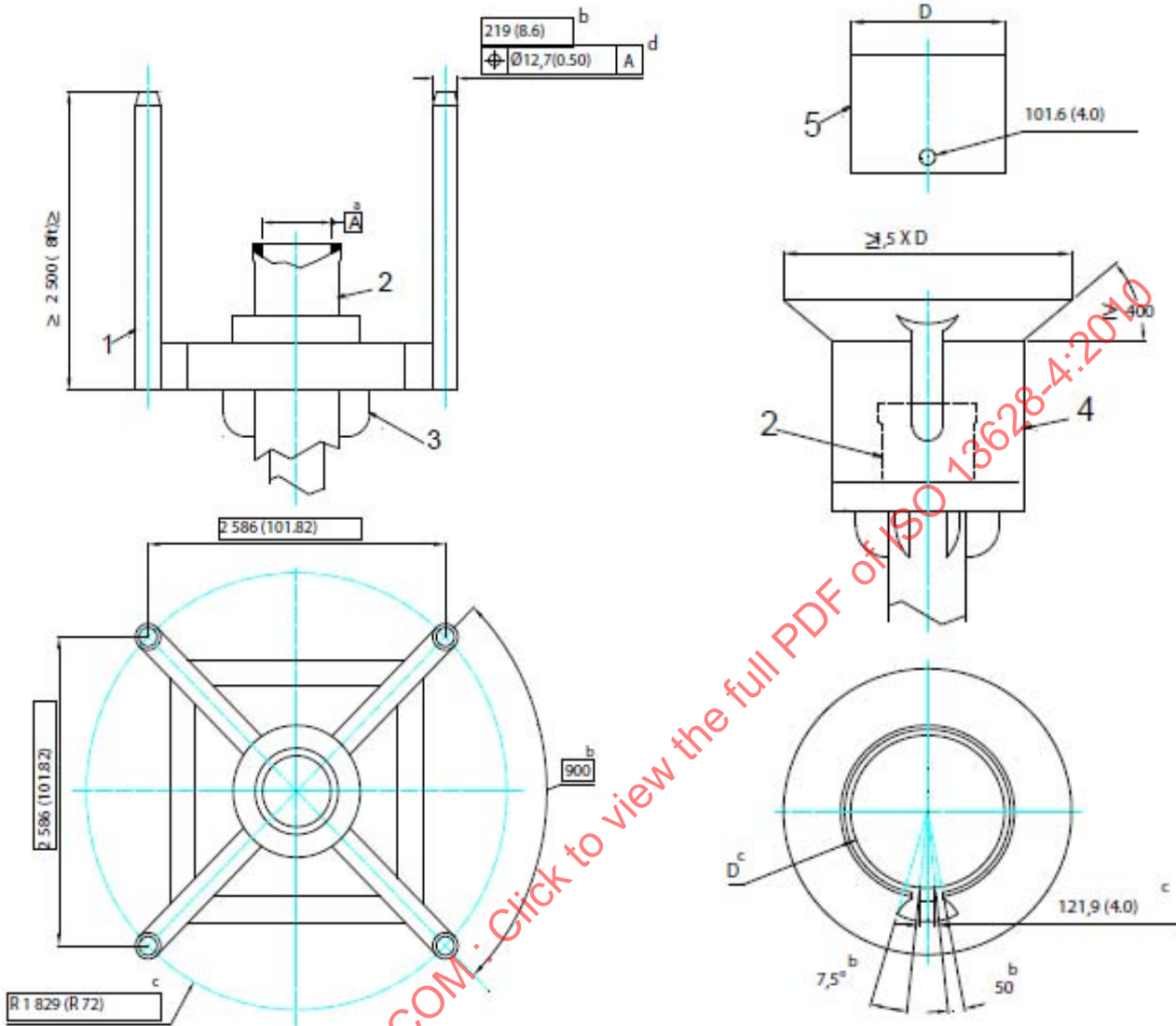

a) Permanent guidebase and guide posts

b) Guidelineless funnel-up

**Key**

- 1 guide post
- 2 wellhead housing
- 3 permanent guidebase
- 4 guide funnel
- 5 wellhead connector

a Cumulative tolerances between all interfacing components shall be less than or equal to the positional tolerance shown.

b Typical.

c Reference dimension.

d Ref ANSI Y14 5M for tolerance explanation.

NOTE Guide posts positional tolerances and determined relative to the wellhead housing bore (Datum -A-), method of measurement to be specified by the manufacturer

**Figure 9 — Tree guide frames**

## 7.16 Tree running tool

### 7.16.1 General

The function of a hydraulic or mechanical tree running tool is to suspend the tree during installation and retrieval operations from the subsea wellhead and to connect to the tree during workover operations. It may also be used to connect the completion riser to the subsea tree during installation, test or workover operations. A subsea wireline/coil tubing BOP or other tool packages may be run between the completion riser and tree running tool. The requirement for soft landing systems should be evaluated.

### 7.16.2 Operating criteria

The purchaser shall specify the operating criteria necessary for the tree installation. The manufacturer shall document the operating limits for which the tree running/retrieval tool is designed.

Tree running/retrieval tools should be designed to be operable in the conditions/circumstances expected to exist during tree running/retrieving operations and well re-entry/workover operations. Specific operating criteria (design loads and angle limits etc.) should consider the maximum surface vessel motions and resulting maximum running string tensions and angles that can occur.

### 7.16.3 Loads

As a minimum, the following loading parameters/conditions shall be considered and documented by the manufacturer when designing the tree running tool:

- internal and external pressure;
- pressure separation loads, which shall be based on worst-case sealing conditions (leakage to the largest redundant seal diameter shall be assumed, unless relief is provided as described in 5.1.2.1.1);
- mechanical preloads;
- riser bending and tension loads;
- environmental loads;
- fatigue considerations;
- vibration;
- mechanical installation (impact) loads;
- hydraulic coupler thrust and/or preloads;
- thermal expansion (trapped fluids, dissimilar metals);
- installation/workover overpull;
- corrosion.

The manufacturer shall specify the loads/conditions for which the equipment is designed. The manufacturer shall state whether the basis of load ratings is stress limits or seal separation limits.

#### 7.16.4 Tree interface

##### 7.16.4.1 General

The tree running tool interfaces with the tree upper connection. This interface shall be designed for emergency release at a running string departure angle as specified by the manufacturer or purchaser. This release shall not cause any damage to the subsea tree such that prevents meeting any other performance requirement.

The tree interface consists of four main component areas:

- locking profile and connector;
- re-entry seal, where applicable;
- extension subs or seals, where applicable;
- controls and instrumentation, where applicable.

For use with dynamically positioned rigs, it is particularly important that the connector have a high-angle release capability and that the connector can be quickly unlocked. In some systems, the EDP connector design can meet these requirements. The manufacturer and/or purchaser shall specify the angle and unlocking time.

##### 7.16.4.2 Locking profile and connector

The tree running tool shall land and lock onto the locking profile of the tree re-entry spool and shall withstand the separating forces resulting from applied mechanical loads and the rated working pressure of the tree as specified by the manufacturer. The tree running tool connector shall meet functional requirements set forth in 7.8.3.

Means shall be provided to prevent trapped fluid from interfering with make-up of the hydraulic or mechanical connector.

##### 7.16.4.3 Re-entry seal

An additional sealing barrier to the environment may be included in the interface between the tree/running tool interface. This seal encircles all bore extension subs and may enclose hydraulic control circuits. The rated working pressure of this gasket shall be specified by the manufacturer.

The pressure-containing capability of this gasket shall be at least equal to the tree-rated working pressure or the maximum anticipated control pressure of the downhole safety valve, whichever is greater, if the SCSSV control circuit(s) is encapsulated by this seal, unless relief is provided as described in 5.1.2.1.1.

##### 7.16.4.4 Extension subs or seals

Extension subs or seals (if used) shall engage the mating surfaces in the upper tree connection for the purpose of isolating each bore. The seal mechanism shall be either metal-to-metal seal(s) or redundant non-metallic seals.

In multi-bore applications that use a re-entry seal as described in 7.16.4.3, each extension sub or seal shall be designed to withstand an external pressure as specified by the manufacturer.

##### 7.16.4.5 Controls and instrumentation

Control system and data gathering instrumentation conduits may pass through the tree running tool body. Specific designs and selection of component materials are the responsibility of the manufacturer.



#### 7.16.4.6 Running string interface

The tree running tool may interface with one or more of the following:

- drilling riser system;
- subsea WCT-BOP or wireline cutter;
- completion riser or stress joint;
- drill pipe or tubing running string;
- LRP;
- wire rope deployment system.

#### 7.16.4.7 Guidance and orientation

Guidance and orientation with other subsea equipment shall conform to or be an extension of the geometries specified in 7.15.2.1.

#### 7.16.4.8 Control system interface

The tree/running tool and/or the workover control interface normally transfers control of the subsea tree from the normal surface production control point to the workover control system. The protocol should be transferred to the workover control system when in workover mode.

#### 7.16.4.9 Secondary release

Hydraulically actuated tree running tool connectors shall be designed with a secondary release method. ROV/diver/remote tooling or through-installation string should be considered. Hydraulic open and close control line piping shall be positioned to allow cutting by diver/ROV or contain a means to vent hydraulic lock pressure if required for the secondary release to function.

#### 7.16.4.10 Position indication

Remotely operated tree running tool connectors shall be equipped with an external position indicator suitable for observation by diver/ROV.

#### 7.16.5 Materials

Tree running tool portions that can be exposed to wellbore fluids shall be made of materials conforming to 5.2.

#### 7.16.6 Factory acceptance testing

Functional testing shall be conducted in accordance with the manufacturer's written specification to verify the operating and release mechanisms, override mechanisms, and locking mechanisms. Testing shall verify that the actual operating forces/pressures fall within the manufacturer's documented specifications.

Pressure containing tree running tools shall be tested per 7.8.4.2, as applicable.

## 7.17 Tree piping

### 7.17.1 General

The term tree piping is used to encompass the requirements for all pipe, fittings or pressure conduits, excluding valves and chokes, from the vertical bores of the tree to the flowline connection(s) leaving the subsea tree. The piping may be used for production, pigging, monitoring, water, gas or chemical injection, service or test of the subsea tree.

Inboard tree piping is upstream of the last tree valve (including choke assemblies). Outboard tree piping is downstream of the last tree valve, and upstream of the flowline connection.

Where tree piping extends beyond the tree guide-frame envelope, protection shall be provided. Access for diver/ROV/ROT to conduct operations about the tree should be considered during the design of flowloop routing and protection.

### 7.17.2 Design

#### 7.17.2.1 Allowable stresses

Outboard tree piping shall conform to the requirements of an existing, documented piping code, such as ANSI/ASME B31.4, ANSI/ASME B31.8 or ANSI/ASME B31.3. As a minimum, the design rated working pressure of the outboard piping shall be equal to the rated working pressure of the tree. Inboard piping shall be designed in accordance with 5.1. In all cases, the following shall be considered:

- allowable stress at working pressure;
- allowable stress at test pressure;
- external loading;
- tolerances;
- corrosion/erosion allowance;
- temperature;
- wall thinning due to bending;
- vibration.

#### 7.17.2.2 Operating parameters

Operating parameters for tree piping shall be based on the service, temperature, material and external loading on each line. Tree piping may be designed to flex to enable connectors to stroke or to compensate for manufacturing tolerances. Special consideration shall be given to piping downstream of chokes, due to possible high fluid velocities and low temperatures; see Clause 5.

#### 7.17.2.3 Tree piping flowloops

Tree piping flowloops may be fabricated using forged fittings or pre-bent sections, or may be formed in a continuous piece. Either "cold" bending or "hot" bending may be used. Bends that are being used in H<sub>2</sub>S service shall conform to the requirements of ISO 15156 (all parts). Induction-bent piping shall be manufactured in accordance with qualified procedures and suppliers.

#### 7.17.2.4 TFL tree piping flowloops

TFL piping flowloops shall also be designed in accordance with ISO 13628-3 for TFL pumpdown systems and 7.10.

#### 7.17.2.5 Pigging

The manufacturer shall document the ability to pig tree piping where such piping is intended to be piggable. Demonstration of the piggability of the intended piping shall be agreed to by the purchaser and manufacturer.

#### 7.17.2.6 Flowline connector interface

The tree piping and flowline connector, when required by the system, shall be designed to allow flexibility for connection in accordance with the manufacturer's written specification. Alternatively, the flexibility may be built into the interface piping system. In the connected position, the combination of induced pipe tension, permanent bend stress, thermal expansion, wellhead deflection and the specified operating pressure shall not exceed the allowable stress as defined in 7.17.2.1. Stresses induced during make up may exceed the level in 7.17.2.1, but shall not exceed material minimum yield strength.

Pressure/temperature transducers and chemical-injection penetrations located on inboard piping shall be equipped with flanged or studded outlets that conform to 7.1 or 7.4.

Penetrations located on outboard piping may be either flanged, threaded or weld-on bosses. Threaded connections shall conform to 7.3, flanged connections shall conform to 7.1 or 7.4, and weld-on bosses shall conform to ANSI/ASME B16.11.

Safeguarding of the transducer connections shall be provided by either locating the ports in protected areas or by fabricating protective guards or covers.

#### 7.17.2.7 Specification break

The location of the specification break between the requirements of this specification (on the tree or CGB) and that of the flowline/pipeline is specifically defined below.

The following apply for tree and tubing head/CGB specification breaks.

- Design code: In accordance with 7.17.1, all inboard piping (upstream of the last valve) shall be designed in accordance with 5.1. Outboard piping shall be in accordance with the specified piping code using the subsea tree's RWP as the piping code's design pressure. Piping codes include API RP 1111, ANSI/ASME B31.4, ANSI/ASME B31.8 or ANSI/ASME B31.3. End connections/fittings for both inboard and outboard piping shall be designed in accordance with 7.1 through 7.4, regardless of piping code used.
- Testing: All testing for inboard piping shall conform to the requirements in accordance with 5.4. Outboard piping shall be in accordance with the specified piping code.
- Materials: Materials for inboard piping shall conform to 5.2. Material for outboard piping and pipe fittings shall conform to the requirements of the specified piping code. For example, wall thickness calculated using ANSI/ASME B31.3 requires the use of ANSI/ASME B31.3 allowable material stresses.
- Welding: Welding of inboard piping shall be in accordance with 5.3. Welding of outboard piping shall conform to the specified piping code or 5.3, whichever is appropriate.

## 7.18 Flowline connector systems

### 7.18.1 General — Types and uses

In 7.18 are covered the tree-mounted flowline connector systems that are used to connect subsea flowlines, umbilicals, jumpers, etc., to subsea trees.

### 7.18.2 Flowline connector support frame

#### 7.18.2.1 General

The connector system shall be supported by an appropriately designed support frame that shall be attached to the subsea tree and/or subsea wellhead. The support frame shall be attached to the subsea wellhead housing, the PGB, GRA or CGB, the tree and/or tree frame or other structural member suitable for accommodating all expected loading conditions.

#### 7.18.2.2 Design

##### 7.18.2.2.1 Loads

The following loads shall be considered and documented by the manufacturers when designing the flowline connector support frame:

- flowline pull-in, catenary and/or drag forces during installation;
- flowline alignment loads (rotational, lateral, and axial) during installation;
- flowline reaction loads due to residual stresses, flowline weight, thermal expansion/contraction and operational/environmental effects;
- reactions from environmental loads on flowline connector running/retrieval and maintenance tools;
- flowline reaction/alignment loads when the tree is pulled for service;
- flowline/umbilical overloads;
- wellhead deflection;
- internal and external pressures (operational and hydrostatic/gas tests).

##### 7.18.2.2.2 Functional requirements

The flowline connector support frame shall transmit all loads imparted by the flowline and umbilical into a structural member to ensure that the:

- tree valves and/or tree piping are protected from flowline/umbilical loads which could damage these components;
- alignment of critical mating components is provided and maintained during installation;
- tree can be removed and replaced without damage to critical mating components.

The flowline connector support frame shall be designed to avoid interfering with the BOP stack.

### 7.18.3 Flowline connectors

#### 7.18.3.1 General

The flowline connector and its associated running tools provide the means for joining the subsea flowline(s) and/or umbilical(s) to the subsea tree. In some cases, the flowline connector also provides means for disconnecting and removing the tree without retrieving the subsea flowline/umbilical to the surface.

Flowline connectors generally fall into three categories:

- a) manual connectors operated by divers or ROVs;
- b) hydraulic connectors with integral hydraulics similar to subsea wellhead connectors;
- c) mechanical connectors with the hydraulic actuators contained in a separate running tool.

#### 7.18.3.2 Design

Flowline connectors shall have a RWP equal to the RWP of the tree. The design of flowline connectors shall be in accordance with the specified piping code using the subsea tree's RWP as the piping code's design pressure. Hydraulic circuits shall be designed in accordance with 5.4.7.

#### 7.18.3.3 Loads

The following loads shall be considered and documented by the manufacturer when designing the flowline connector and associated running tools:

- flowline pull-in, catenary and/or drag forces during installation;
- flowline alignment loads (rotational, lateral, and axial) during installation;
- flowline reaction loads due to residual stresses, flowline weight, thermal expansion/contraction and operational/environmental effects;
- reactions from environmental loads on flowline connector running/retrieval and maintenance tools;
- flowline reaction/alignment loads when the tree is pulled for service;
- flowline/umbilical overloads;
- wellhead deflection;
- internal and external pressures (operational and hydrostatic/gas tests);
- load created by a loss of stationkeeping.

The flowline connector shall ensure sealing under all pressure and external loading conditions specified.

When actuated to the locked position, hydraulic flowline connectors shall remain self-locked without requiring that the hydraulic pressure be maintained. Connectors shall be designed to prevent loosening due to cyclic installation and/or operational loading. This shall be achieved by a mechanical locking system or backup system or other demonstrated means. Mechanical locking devices shall incorporate a release mechanism in the event of malfunction.

#### 7.18.3.4 Dimensions

The dimensions of the flowline connector's flow passages should be compatible with the drift diameters of the flowlines.

If TFL service is specified, the TFL flow passage geometry shall meet the dimensional requirements of ISO 13628-3 for TFL pumpdown systems.

If pigging capability is specified, the flowline connector flow passages should be configured to provide transitions and internal geometry compatible with the type(s) of pig specified by the manufacturer.

The end connections used on the flowline connector (flanges, clamp hubs, or other types of connections) shall comply with 7.1 through 7.6. Preparations for welded end connections shall comply with 7.1.2.

The termination interface between the flowline connector and the flowline shall conform to the requirements of 7.1 through 7.4 at the flowline connector side, and to the requirements of the specified piping code on the flowline side.

#### 7.18.3.5 Functional requirements

The flowline connector and/or its associated running tool(s) should provide positioning and alignment of mating components such that connection can be accomplished without damage to sealing components or structural connection devices. Seals and sealing surfaces shall be designed such that they can be protected during installations operations.

Primary seals on flowline connectors shall be metal-to-metal. Glands for the metal seals shall be inlaid with corrosion-resistant material unless the base material is corrosion-resistant.

Where multiple bore seals are enclosed within an outer environmental or secondary seal, bi-directional bore seals shall be provided to prevent cross-communication between individual bores.

The flowline connection system shall provide means for pressure testing the flowline and/or umbilical connections following installation and hook-up.

The flowline connector shall have the same working pressure rating as the subsea tree. Means shall be provided for pressure-testing the tree and all its associated valves and chokes without exceeding the test pressure rating of the flowline connector.

The flowline connector should have a visual means for external position verification.

Flowline connector components located downstream of the choke may have a lower temperature rating than the tree system.

### 7.18.4 Testing

#### 7.18.4.1 General

In 7.18.4 is covered the testing of the flowline connector system, which includes the flowline-connector support frame, the flowline connector, the flow loops and associated running/retrieval and maintenance tools.

#### 7.18.4.2 Validation testing

Tests shall be conducted to verify the structural and pressure integrity of the flowline connector system under the rated loads specified by the manufacturer in accordance with 6.1. Such tests shall also take into consideration the:

- simulated operation of all running/retrieval tools under loads typical of those expected during actual field installations;

- simulated pull-in or catenary flowline loads (as applicable) during flowline installation and connection;
- removal and replacement of primary seals for flowline connectors for remotely replaceable seals;
- functional tests of required running/retrieval and maintenance tools;
- maximum specified misalignment;
- connection qualification test including torsion, bending, pressure and temperature.

The manufacturer shall document successful completion of the above tests.

#### 7.18.4.3 Factory acceptance testing

Factory acceptance testing is as given in a) to c) following.

##### a) Structural components:

All mating structural components shall be tested in accordance with the manufacturer's written specification for fit and function using actual mating equipment or test fixtures.

##### b) Pressure-containing components:

Functional testing shall be conducted in accordance with the manufacturer's written specification to verify the primary and secondary operating and release mechanisms, override mechanisms and locking mechanisms. Testing shall verify that the actual operating forces/pressures fall within the manufacturer's documented specifications.

Flowline connectors shall be hydrostatically tested in accordance with the specified piping code using the subsea tree's RWP as the piping code's design pressure. In addition, the flowline connector shall be tested in accordance with 7.8.4.2, as applicable.

##### c) Running tools:

Functional testing of running/retrieval and maintenance tools shall be conducted in accordance with the manufacturer's written specification to verify the primary and secondary operating and release mechanisms, override mechanisms and locking mechanisms. Testing shall verify that the actual operating forces/pressures fall within the manufacturer's documented specifications.

#### 7.18.5 *In-situ* testing

*In-situ* testing is beyond the scope of this part of ISO 13628. However, if *in-situ* testing of flowlines is required at pressures above the tree-rated working pressure, a test isolation valve with a working pressure higher than that of the tree can be required.

### 7.19 Ancillary equipment running tools

#### 7.19.1 Design

##### 7.19.1.1 Operating criteria

The manufacturer shall document the operating criteria, clearance and access criteria for ancillary equipment and their running/retrieval tools as it pertains to the mounting on the subsea tree. Ancillary equipment may include control pods, retrievable chokes and flowline connection equipment.

Running/retrieval and testing tools should be designed such that they are operable in the conditions/circumstances expected to exist during running/retrieving operations and workover operations.

Specific operating criteria (design loads and angle limits, etc.) should consider the maximum surface-vessel motions and resulting maximum running-string tensions and angles that can occur.

#### 7.19.1.2 Loads and component strength

As a minimum, the following loading parameters/conditions shall be considered and documented by the manufacturer when designing the running tool:

- internal and external pressure;
- pressure separation loads, which shall be based on worst-case sealing conditions (leakage to the largest redundant seal diameter shall be assumed);
- mechanical preloads;
- running string bending and tension loads;
- environmental loads;
- fatigue considerations;
- vibration;
- mechanical installation (impact) loads;
- hydraulic coupler thrust and/or preloads;
- installation/workover overpull;
- corrosion.

The manufacturer shall specify the loads/conditions for which the equipment is designed. The manufacturer shall document the load/capacity for their running tool.

#### 7.19.1.3 Running tool interfaces

The running tool shall be capable of connection, functioning and disconnection at the maximum combined loads, as specified in 7.19.1.2.

Control and/or test connections that pass through the interface shall retain their pressure integrity at the maximum combined load rating.

#### 7.19.1.4 Guidance and orientation

If the subsea tree structure is used for alignment and orientation, running-tool guidance structures shall conform to or be an extension of the geometries specified in 7.15.2.1. Independent guidance and orientation shall be designed in accordance with the manufacturer's written specification.

#### 7.19.1.5 Remote intervention equipment

Remote intervention fixtures shall be designed in accordance with requirements of ISO 13628-8 or ISO 13628-9.



## 7.20 Tree-mounted hydraulic/electric/optical control interfaces

### 7.20.1 General

Tree-mounted hydraulic/electric/optical control interfaces covered by this part of ISO 13628 include all pipes, hoses, electric or optical cables, fittings or connectors mounted on the subsea tree, flowline base or associated running/retrieving tools for the purpose of transmitting hydraulic, electric or optical signals or hydraulic or electric power between controls, valve actuators and monitoring devices on the tree, flowline base or running tools and the control umbilical(s) or riser paths.

### 7.20.2 Design

#### 7.20.2.1 Pipe/tubing/hose

Allowable stresses in pipe/tubing shall be in accordance with ANSI/ASME B31.3. Hose design shall conform to ANSI/SAE J517 and shall include validation to ANSI/SAE J343. Design shall take into account the

- allowable stresses at working pressure;
- allowable stresses at test pressure;
- external loading;
- collapse;
- manufacturing tolerances;
- fluid compatibility;
- flow rate;
- corrosion/erosion;
- temperature range;
- vibration.

#### 7.20.2.2 Size and pressure

All pipe/tubing/hose shall be 6,0 mm (0,25 in) diameter, or larger. Sizes and pressure ratings of individual tubing runs shall be determined to suit the functions being operated. Consideration shall be given to preventing restrictions in the control tubing that can cause undesirable pressure drops across the system. Injection lines, downhole hydraulic, connector/gasket seals test lines, pressure monitor lines or any line that by design is exposed to wellbore fluids shall be rated at the working pressure of the tree. SCSSV lines shall be rated at the specified SCSSV operating pressure (see 5.1.2.1.1 and 9.2.7 for additional information).

#### 7.20.2.3 Optical cables and cable penetrations

Optical fibres shall be routed inside fluid-filled conduits; typically a fluid-filled hose for flying-lead or short-cable applications, and a metal tube for longer umbilical applications. Optical terminations shall include qualified penetrations to prevent fluid leakage from these conduits. Optical penetrations into pressure-containing cavities or piping systems shall be qualified for the full differential pressure across the penetration. Optical fibres run in fluid-filled hoses shall include sufficient internal fibre slack length to prevent fibre tensioning under the expected load conditions.

#### 7.20.2.4 Envelope

All pipe/tubing/hose/electric or optical cable shall be within the envelope defined by the guide frames of the tree, running/retrieving tool or the flowline base.

#### 7.20.2.5 Routing

The routing of all conduits (pipe/tubing/hose/electric or optical cable) shall be carefully planned and conduits should be supported and protected to minimize damage during testing, installation/retrieval and normal operations of the subsea tree. Free spans shall be avoided and, where necessary, conduits shall be supported and/or protected by trays/covers. The bend radius of cold-bent tubing shall not exceed the requirements of ISO 15156 (all parts) for cold-working. Cold bends shall be in accordance with ANSI/ASME B31.3. Tubing running to hydraulic tree connectors, running tool connectors and flowline connectors shall be accessible to divers/ROV/ROT, such that it can be disconnected, vented or cut, in order to release locked-in fluid and allow mechanical override.

Electrical cables should be routed such that any water entering the compensated hoses moves away from the end terminations by gravity. Electrical signal cables shall be screened/shielded to avoid cross talk and other interferences.

#### 7.20.2.6 Small bore tubing and connections

Hydraulic couplers, end fittings and couplers shall meet or exceed requirements of the existing piping code used for the piping/tubing/hose design in 7.20.2.1. Small-bore [less than 25,4 mm (1,0 in) ID] tubing runs should be planned so as to use the minimum number of fittings or weld joints. Welding may be used to join tubes at the manufacturer's discretion. Fittings and socket welds may be used on all small-bore tubing that does not penetrate the wellbore. Fittings and socket welds may be used on small-bore tubing that penetrates the wellbore (for example, chemical injection or SCSSV) if they are outboard of two isolation devices, one of which is remotely operated. Connections on small-bore tubing that penetrates the wellbore inboard of the two isolation devices shall be full-penetration butt welds as specified in 5.3.1. Tubing and hose fittings shall be tested to verify that they are not isolated from the cathodic protection system.

Quality requirements for small-bore tubing and connections shall be to the manufacturer's written specification.

The coupling stab/receiver plate assembly shall be designed to withstand the rated working pressure applied simultaneously in every control path without deforming to the extent that any other performance requirement is affected in accordance with the manufacturer's written specification. In addition, when non-pressure balanced-control couplers are used, the manufacturer shall determine and document the rated water depth at which coupler plate/junction plate can decouple the control couplers without deformation damage to the plate assemblies with zero pressure inside the couplers. The manufacturer shall determine and document the force required for decoupling at the rated water depth with zero pressure inside the couplers.

Proprietary coupler stab and receiver-plate designs shall meet the test requirements in 7.20.5.

#### 7.20.2.7 Electrical connectors

Electrical connection interfaces made up subsea shall prevent the ingress of water or external contaminants. The retrievable half of conductive-type electrical connectors should contain seals, primary compensation chambers, penetrators, springs, etc. The design of the non-retrievable half should consider the effects of corrosion, calcareous growth, cathodic protection, etc.

#### 7.20.2.8 Optical connectors

Optical-connection interfaces made up subsea shall feature pressure-compensated chambers in which the final optical-fibre connections are engaged. The configuration shall prevent the ingress of water or external contaminants that can potentially interfere with the optical fibre engagement. Optical connectors should ideally include an automatic mechanism to wipe the face of the fibres prior to final engagement of the mating fibres.

### 7.20.2.9 Control line stabs/couplers

As a minimum, control line stabs for the SCSSV, production master valve(s), production wing valve, and annulus master valve shall be designed so as not to trap pressure when the control stabs are separated except where allowed in 9.2.9.

Both vented and non-vented control stabs shall be designed to minimize seawater ingress when connected/disconnected. They shall be capable of disconnection at the rated internal working pressure, without detrimental effects to the seal interface. The half containing the seals shall be located in the retrievable assemblies. In addition to the internal working pressure, the control stabs shall be designed to withstand external hydrostatic pressure at manufacturer's rated water depth. Stabs shall be capable of sealing at all pressures within their rating, in both the mated and un-mated (non-vented type) condition, except as noted in 7.20.

**NOTE** Venting control stab connections are primarily intended as a well control feature of a subsea tree when the tree is controlled by direct or a piloted hydraulic control system. Subsea tree interface designs with individual hydraulic control lines often feature poppet connections to protect the line from debris and seawater ingress. If the control stab connection were separated during a severe damage or emergency disconnect event before hydraulic line pressure can be bled down, the individual stab's poppet can trap hydraulic control line pressure behind the poppet, preventing the above mentioned fail-closed safety devices from closing. The venting control stab requirement is intended to circumvent the trapped pressure possibility.

The venting control stab requirement is not intended for other control system configurations or their internal interface connections providing a fail-safe vent feature is included to allow fail-closed safety devices to close. ISO 13628-6/API 17F provides guidance on proper avoidance of trapped hydraulic pressure situations for these control systems.

### 7.20.2.10 Alignment/orientation of receiver plates

Multi-port hydraulic receiver plates, as used at the control pod, tree cap, tree running tool, etc., shall have an alignment system to ensure correct alignment of hydraulic couplers prior to engagement of their seals. The stab's couplers shall be mounted in a manner to accommodate any misalignment during make-up. The alignment shall also not allow miscommunication between umbilical lines and tree plumbing, i.e. shall align in one orientation only.

## 7.20.3 Assembly practice

### 7.20.3.1 Cleanliness during assembly

Practices should be adopted during assembly to maintain tubing/piping/fittings cleanliness.

### 7.20.3.2 Flushing

After assembly, all tubing runs and hydraulically actuated equipment shall be flushed to meet the cleanliness requirements of SAE/AS 4059. The class of cleanliness shall be as agreed between the manufacturer and purchaser. Final flushing operations shall use a hydraulic fluid compatible with the fluid being used in the field operations. Equipment shall be supplied filled with hydraulic fluid. Fittings, hydraulic couplings, etc., shall be blanked off after completion of flushing/testing to prevent particle contamination during storage and retrieval.

## 7.20.4 Materials

### 7.20.4.1 Corrosion

Pipe/tubing and end fittings, connectors and connector plates shall be made of materials that can withstand atmospheric and seawater corrosion.

Pipe/tubing/hoses in contact with wellbore fluids or injected chemical shall be made from materials compatible with those fluids. Recommended test procedures can be found in Annex J.

#### 7.20.4.2 Seal materials

Seal materials shall be suitable for the type of hydraulic control fluid being used in the system. Seals in contact with wellbore fluids or injected chemicals shall be made of materials compatible with those fluids.

#### 7.20.5 Testing

##### 7.20.5.1 Small bore tubing, hoses, and connections

Testing of assembled pipe/tubing/hose and end fittings, connectors and connector plates exposed to production pressure shall conform to 5.4, except that the test pressure shall not exceed the test pressure of the lowest pressure-rated component in the system in accordance with 5.4.7. Testing of assembled pipe/tubing/hose and end fittings, connectors and connector plates carrying control fluid shall be in accordance with ANSISME B31.3 as specified in 5.4.7. FAT for hoses on equipment that is accessible at the surface by location or operational use shall be repeated for hoses more than five years old.

##### 7.20.5.2 Stab/receiver plate assembly

The stab/receiver plate assembly shall be tested to rated working pressure applied simultaneously in every control path in accordance with the manufacturer's written specification.

##### 7.20.6 Connector plate marking

Each connector plate shall be permanently marked with the following minimum information:

- a) its part number;
- b) path designation numbers or letters identifying each path/connector.

All part numbers, path designations, operating pressures of each path and other pertinent information should be included in the design documentation.

#### 7.21 Subsea chokes and actuators

##### 7.21.1 General

In 7.21 are covered subsea chokes, actuators and their assemblies used in subsea applications. It provides requirements for the choke/actuator assembly performance standards, sizing, design, materials, testing, marking, storage and shipping. Subsea choke applications are production, gas lift and injection.

The design of the tree system should consider any requirements for replacement of high-wear items of the subsea choke, including isolation prior to retrieval and testing following re-installation. Placement of the choke should allow adequate spacing for retrieval, and diver/ROV override operations.

##### 7.21.2 Subsea chokes

###### 7.21.2.1 General

###### 7.21.2.1.1 Adjustable chokes

Adjustable chokes have an externally controlled, variable-area orifice trim and may be coupled with a linear scale valve-opening-indicating mechanism.

### 7.21.2.1.2 Positive chokes

Positive chokes accommodate replaceable parts having a fixed orifice dimension, commonly known as flow beans.

### 7.21.2.1.3 Orifice configuration

A variety of orifice configurations (sometimes referred to as “trim”) are available for chokes. Six of the most common adjustable orifice configurations are rotating disc, needle and seat, plug and cage, sliding sleeve and cage, cage and external sleeve, and multistage. Examples of orifice configurations are shown in Figure 10. Optimum orifice configuration is selected on the basis of operating pressures, temperatures and flow media.

### 7.21.2.1.4 Choke capacity

The manufacturer shall document the flow rate based on maximum orifice, pressure, temperature and fluid media.

The choke flow capacity is determined in accordance with requirements of ISA 75.01.01 and ISA 75.02 for anticipated or actual production flow rate and fluid conditions (pressures and temperature). The information shown in Annex M for purchasing guidelines shall be supplied to the choke manufacturer for the sizing of the choke.

## 7.21.2.2 Design

### 7.21.2.2.1 General

Subsea chokes shall be designed in accordance with the general design requirements of 5.1.

### 7.21.2.2.2 Design and operating parameters

Manufacturers shall document the following design and operating parameters of the subsea choke:

- maximum pressure rating;
- maximum reverse differential pressure rating;
- maximum  $C_v$ ;
- temperature rating:
  - maximum;
  - minimum;
- PSL level;
- material class;
- type of choke (retrieval style):
  - non-retrievable,
  - diver assist retrievable,
  - tool retrievable;
- functional style of choke:
  - adjustable choke prep. for manual actuator,
  - adjustable choke prep. for hydraulic actuator,

- end connections:
  - size and pressure rating,
  - ring gasket size (if applicable);
- type of operation:
  - ROV,
  - ROT,
  - diver assist,
  - end effector configuration;
- water depth rating.

#### 7.21.2.2.3 Pressure rating

Subsea chokes with RWPs of 34,5 MPa (5 000 psi), 69 MPa (10 000 psi) or 103,5 MPa (15 000 psi) are covered by this International Standard.

For chokes having end connections with different pressure ratings, the rating of lowest-rated pressure-containing part shall be the rating of the subsea choke. The rated working pressure of the subsea choke shall be equal to or greater than the rated working pressure of the subsea tree.

#### 7.21.2.2.4 Temperature rating

All pressure-containing components of subsea chokes shall be designed for the temperature ratings specified in 5.1.2.2. For subsea chokes, the maximum temperature rating is based on the highest temperature of the fluid that can flow through the choke. Subsea chokes shall have a maximum temperature rating equal to or greater than the tree. The minimum temperature rating of subsea chokes shall be in accordance with the manufacturer's written specifications but equal to or less than the tree rating.

#### 7.21.2.2.5 End connections

End connections for chokes shall be as specified in 7.1 to 7.6.

#### 7.21.2.2.6 Vent requirements

Subsea chokes shall be designed to prevent internal cavities from trapping pressure. The system shall have the means to facilitate pressure being vented prior to releasing and during landing of the body-to-bonnet connector.

#### 7.21.2.2.7 External pressure requirements

Subsea chokes shall be designed to withstand external hydrostatic pressure at the maximum rated water depth. The design shall prevent the ingress of water from external hydrostatic pressure.

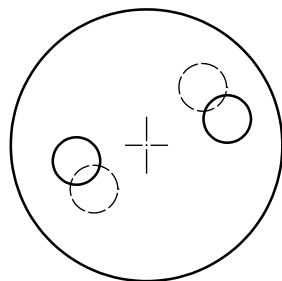

a) Rotating discs

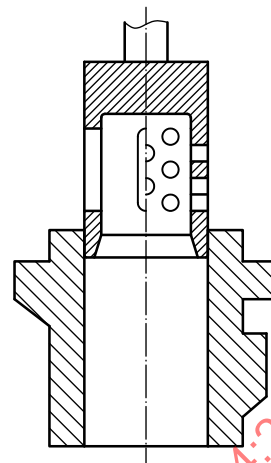

d) Sliding sleeve and cage

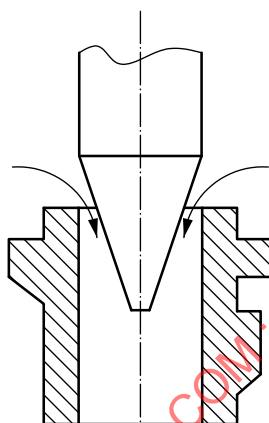

b) Needle and seat

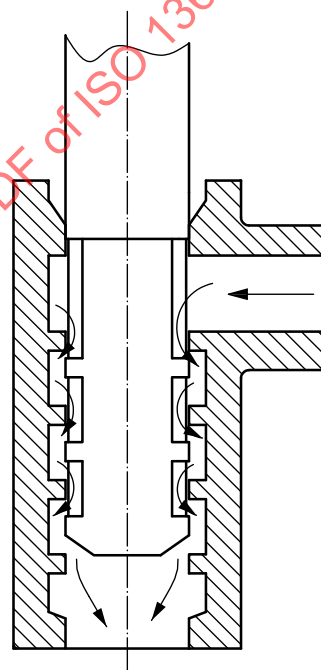

e) Multi-stage/cascade

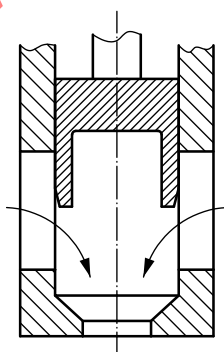

c) Plug and cage

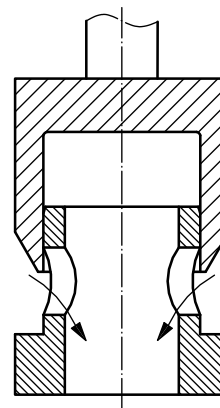

f) Cage and external sleeve

Figure 10 — Choke common orifice configurations

7.21.2.3 Choke testing

7.21.2.3.1 Factory acceptance test

Hydrostatic testing of subsea chokes shall be in accordance with 5.4. For FAT data sheet for subsea choke, refer to Tables 23 and 24.

**Table 23 — Example documentation of the factory acceptance testing for the operational test of a subsea choke with hydraulic operator**  
(choke with hydraulic operator)

[\(Click here to access an electronic revisable version of this form.\)](#)

Factory acceptance test form for the operational test of a subsea choke with hydraulic operator (choke with hydraulic operator)													
Test no.	Cycle no.	Choke pressure	Hydraulic pressure required to		Verification that the choke operated smoothly and without backdriving						Reversing pressure <sup>a</sup>		
					During opening			During closing					
			Close choke	Open choke	Yes	No	Witness	Yes	No	Witness	Open	Close	
1	1	Atmospheric											
	2	Atmospheric											
	3	Atmospheric											
2	1	Working pressure											
	2	Working pressure											
	3	Working pressure											
	4	Working pressure											
	5	Working pressure											

<sup>a</sup> Pressure to reverse operating direction subsequent to overstepping shall be less than 90 % of hydraulic pressure utilized to overstep or over travel on linear actuators.



**Table 24 — Example documentation of the factory acceptance testing for a subsea choke with mechanical operator and/or hydraulic operator with mechanical override operational test**  
 (choke with manual operator, and choke hydraulic operator with manual override)  
[\(Click here to access an electronic revisable version of this form.\)](#)

Factory acceptance test form for a subsea choke with mechanical operator and/or hydraulic operator with mechanical override operational test (choke with manual operator, and choke hydraulic operator with manual override)														
Test No.	Cycle No.	Choke pressure	Verification that the choke operated smoothly and without backdriving within the manufacturer's specified torque limit											
			During opening					During closing						
			Yes	No	Starting torque	Running torque	Witness	Yes	No	Starting torque	Running torque	Witness		
1	1	Atmospheric pressure												
	2	Atmospheric pressure												
	3	Atmospheric pressure												
2	1	Working pressure												
	2	Working pressure												
	3	Working pressure												
	4	Working pressure												
	5	Working pressure												

### 7.21.3 Subsea choke actuators

#### 7.21.3.1 General

In 7.21.3 are covered manual and hydraulic actuators for subsea applications. The design of electric-power or motor-driven actuators, position indicators and control feedback equipment are beyond the scope of this part of ISO 13628.

#### 7.21.3.2 Design

##### 7.21.3.2.1 General

The following requirements apply to subsea choke actuators.

- a) The design of subsea choke actuators shall comply with 5.1.
- b) Design shall consider marine growth, fouling, corrosion, hydraulic operating fluid and, if exposed, the well-stream fluid(s).
- c) Subsea choke actuators shall conform to the temperature ratings of 5.1.2.2.

#### 7.21.3.2.2 Manual actuators

The following requirements apply to manual actuators.

- a) The design of the manual actuation mechanism shall take into consideration ease of operation, adaptability of diver tools, ADSs and/or ROVs for operations.
- b) Manufacturers of manual actuators or overrides for subsea chokes shall document maintenance requirements and operating information, such as the number of turns to open, operating torque, maximum allowable torque and, where appropriate, linear force to actuate.
- c) Rotary-operated subsea chokes shall be turned in the counter-clockwise direction to open and the clockwise direction to close as viewed from the end of the stem.
- d) Remote intervention fixtures shall be designed in accordance with requirements of ISO 13628-8 or ISO 13628-9.
- e) Manufacturer shall document the design and operating parameters of subsea choke manual actuators as listed in 7.22.3.2.4.

#### 7.21.3.2.3 Hydraulic actuators

The following requirements apply to hydraulic actuators.

- a) Hydraulic actuators shall be designed for a hydraulic rated working pressure rating of either 10,3 MPa (1 500 psi), 20,7 MPa (3 000 psi), or 34,5 MPa (5 000 psi) or in accordance with the manufacturer's written specification.
- b) Opening and closing force and/or torque of hydraulic actuators shall operate the subsea choke when the choke is at the most severe design operating conditions without exceeding 90 % of the hydraulic rated working pressure as specified in 7.21.3.2.3 a).
- c) Hydraulic actuators shall be designed for a specific choke or specific group of chokes with consideration of the operating characteristics and maximum rated working conditions (temperature range, pressure, depth) of those chokes.
- d) Hydraulic actuators shall be designed to operate without damage to the choke or actuator (to the extent that prevents meeting any other performance requirement), when hydraulic actuation pressure (within its rated working pressure) is either applied or vented under any choke-bore pressure conditions, or stoppage of the choke-bore sealing mechanism at any intermediate position.
- e) The design of the hydraulic actuators shall consider the effects of the rated working pressure within the choke, external hydrostatic pressure at the manufacturer's maximum depth rating and maximum hydraulic operating pressure.
- f) Liquid-filled hydraulic actuators shall be designed with volume compensation to accommodate the temperature range specified, fluid compressibility and operational volume change.
- g) Manufacturer shall document design and operating parameters of subsea choke hydraulic actuators as listed in 7.22.3.2.5.
- h) Application of operating pressure shall be possible without causing damage, even if the manual override has been operated.
- i) Rotary override shall be turned in the counter-clockwise direction to open and the clockwise direction to close as viewed from the end of the stem.

#### 7.21.3.2.4 Design and operating parameters of manual actuators for subsea chokes

The following parameters shall be specified:

- operating torque input (non-impact);
- maximum rated torque capacity (non-impact);
- type and size of interface (ROV) for manual operation;
- material class;
- temperature rating;
- number of turns full open to full close.

#### 7.21.3.2.5 Design and operating parameters of hydraulic actuators for subsea chokes

The following parameters shall be specified:

- design type (ratchet, stepping, rotary, linear actuators);
- maximum output torque capacity;
- material class;
- temperature rating;
- full stroke definition;
- hydraulic fluid compatibility;
- hydraulic cylinder(s):
  - number of cylinders,
  - volume,
  - pressure rating: maximum hydraulic operating pressure and minimum hydraulic operating pressure;
- maximum actuator operation speed;
- type of local position indicator (if any);
- manual override (if supplied):
  - ROV assist or diver assist,
- maximum input torque capacity:
  - operation (non-impact),
  - maximum (non-impact),
- type and size of interface (ROV) for manual operation hex,
- number of turns to open or close the choke;
- water depth rating;
- type of volume compensation device (if any):
  - bladder,
  - piston.

7.21.3.2.6 Documentation

The actuator manufacturer shall prepare an installation and service manual.

7.21.3.3 Actuator testing

The following requirements apply to actuator testing.

- a) Subsea choke actuators shall be factory acceptance tested in accordance with ISO 10423, except for backseating. All test data shall be recorded on a data sheet similar to that indicated in Table 25.
- b) When subsea choke actuators are shipped separately, the actuators shall be assembled with a test fixture that meets the specified choke operating parameters, and tested as specified in 7.21.4.2.

7.21.4 Choke and actuator assembly

7.21.4.1 Design

Subsea chokes shall be assembled with an actuator designed to operate that choke.

Subsea choke and actuator assembly designated as “fail in the last position” shall be designed and fabricated to prevent backdriving by the choke under all operating conditions, at the loss of hydraulic actuator pressure.

Manual choke actuators shall prevent backdriving under all operating conditions.

Means shall be provided to prevent wellbore fluid from pressuring the actuator.

**Table 25 — Example data sheet for the factory acceptance testing of an hydraulic actuator**

[\(Click here to access an electronic revisable version of this form.\)](#)

Example data sheet for the factory acceptance testing of an hydraulic actuator			
<b>A: Actuator data</b>			
<b>Manufacturer</b>			
Model no.	_____	Part no.	_____
Serial no.	_____	Size	_____
Hydraulic pressure rating	_____		
Temperature rating	_____	PSL level	_____
Actuator separate	_____	<input type="checkbox"/> or with choke <input type="checkbox"/>	_____
<b>B: Actuator cylinder seal test (hydrostatic test)</b>			
<b>Test pressure</b>			
Cylinder 1	_____		
Holding period	_____	Beginning	_____
		Completion	_____
		Total test time (min)	_____
Cylinder 2			
Holding period	_____	Beginning	_____
		Completion	_____
		Total test time (min)	_____
Performed by	_____	Date	_____
<b>C: Performance test for actuators shipped separately</b>			
See Table 23.			

#### 7.21.4.2 Choke/actuator assembly factory acceptance test

##### 7.21.4.2.1 General

The subsea choke and actuator assembly shall be tested to demonstrate proper assembly and operation. All test data shall be recorded on a data sheet similar to that indicated in Tables 26 and 27. The test data sheet shall be signed and dated by the person(s) performing the test(s).

##### 7.21.4.2.2 Hydraulic actuator cylinder seal test

The actuator seals shall be pressure-tested in two steps by applying pressures of 20 % and 100 % of the RWP of the actuator. No visible seal leakage shall be allowed. The minimum test duration for each pressure test shall be 3 min. The test period shall not begin until the test pressure has been reached and has stabilized and the pressure-monitoring device has been isolated from the pressure source. The test pressure reading and time at the beginning and at the end of each pressure-holding period shall be recorded.

##### 7.21.4.2.3 Operational test

**7.21.4.2.3.1** Each subsea choke and actuator assembly shall be tested for proper operation in accordance with this part of ISO 13628. This shall be accomplished by actuating the subsea choke from the fully closed position to the fully open position a minimum of three times with the choke body at atmospheric pressure and a minimum of five times with the choke body at rated working pressure.

The operational test of each subsea choke and actuator shall include the recording of the test data as given in Table 24 and/or Table 25.

**7.21.4.2.3.2** For assemblies with hydraulic operators, the actuation of the choke shall be accomplished with an actuator pressure equal to or less than 90 % of the rated operating pressure, and the following information shall be recorded on a data sheet, such as that shown in Table 23:

- pressure inside choke body;
- actuator pressure required to close choke;
- actuator pressure required to open choke;
- verification that the choke operated smoothly and without backdriving;
- actuator pressure to reverse operational direction subsequent to operation to engage the travel end stop.

**7.21.4.2.3.3** For assemblies with manual operators, the following information shall be recorded on a data sheet such as illustrated by Table 24:

- pressure inside choke body;
- verification that the choke operated smoothly and without backdriving within the manufacturer's specified torque limit.

**7.21.4.2.3.4** For assemblies with hydraulic operators and manual overrides, the sets of tests outlined in 7.21.4.2.3.2 and 7.21.4.2.3.3 shall be accomplished and the results recorded on a data sheet such as those given in Tables 26 and 27.

**Table 26 — Example data sheet for the factory acceptance testing of a subsea choke**  
[\(Click here to access an electronic revisable version of this form.\)](#)

Example data sheet for the factory acceptance testing of a subsea choke			
A: Choke data			
Manufacturer			
Model No.		Part No.	
Serial No.		Orifice size	
Working pressure		Test pressure	
Temperature rating		PSL level	
B: Hydrostatic test			
Test pressure			
First holding period	Beginning		
	Completion		
	Total test time (min)		
Second holding period	Beginning		
	Completion		
	Total test time (min)		
Performed by		Date	
C: Operational test of subsea choke with handwheel			
Cycle number	Pressure in choke MPa (psi)	Remarks	
Test 1			
1	0,103 (15)		
2			
3			
Test 2			
1	Working pressure of choke		
2			
3			
4			
5			
Performed by		Date	

### 7.21.5 Insert retrievable choke

#### 7.21.5.1 General

Insert retrievable chokes shall have a visual marking system indicating full makeup and full release position of the insert to body connector system.

#### 7.21.5.2 Connector

Connector system shall be designed to be self locking in the clamped position to prevent backdriving in service under all operational loads.

A rotary connector drive shall be turned in the counter-clockwise direction to open the connector and the clockwise direction to close as viewed from the end of the stem.

#### 7.21.5.3 Seal system

It shall be possible to test the insert to the body seat seal to validate seal function. A blanking trim may be utilized when performing this test.

#### 7.21.5.4 Design and operating parameters of connectors for subsea chokes

The following parameters shall be specified:

- clamp makeup torque or linear thrust rating;
- clamp maximum input torque or maximum linear thrust rating;
- type and size of interface (ROV);
- number of turns to open or close, or linear travel, to operate the clamp.

#### 7.21.6 Materials

Both subsea chokes and subsea actuators shall be made of materials that meet the applicable requirements of 5.2 and the requirements of ISO 10423.

#### 7.21.7 Welding

Welding of pressure-containing components shall be performed in accordance with the requirements given in 5.3. Welding of pressure-controlling ("trim") components shall comply with the manufacturer's written specifications.

#### 7.21.8 Marking

Marking shall be as specified in 5.5. In addition, subsea chokes, manual actuators, hydraulic actuators and choke/actuator assemblies shall be marked as given in Tables 27, 28, 29 and 30, respectively.

### 7.22 Miscellaneous equipment

#### 7.22.1 General

A variety of miscellaneous tools and accessories are used with subsea wellhead and subsea completion equipment. In 7.2.2 are identified the requirements for some common tools. These tools and other miscellaneous equipment not specifically listed here shall be designed and manufactured in accordance with the structural requirements, stress limitations and documentation requirements of 5.1.

**Table 27 — Marking data sheet for subsea chokes**

Marking	Location
Manufacturer's name and/or trademark	Body or nameplate
Model number and type	Body or nameplate
Maximum working pressure rating	Body or nameplate
Serial or identification number unique to the particular choke	Body or nameplate
Maximum orifice size in diameter increments of 0,4 mm (1/64 in.)	Body or nameplate
Direction of flow	Body
ISO requirements — ISO 13628-4 — PSL level — Performance level — Material class — Temperature rating — Date (month/year)	Body or nameplate
Flange size, pressure and ring joint designation	Flange(s) periphery
Material and hardness	Body and bonnet (cap)
Part number	Body or nameplate

**Table 28 — Marking data sheet for manual subsea choke actuators**

Marking	Location
Manufacturer	Body or nameplate
Model number	Body or nameplate
Input torque rating (maximum) - Nm (ft-lbs)	Nameplate
Maximum output torque - Nm (ft-lbs)	Nameplate
Number of turns to open	Nameplate
Date (month/year)	Nameplate
Serial number (if required)	Nameplate
Part number	Nameplate
ISO requirements	Nameplate
— Temperature range	
— ISO 13628-4	
— Date (month/year)	



Table 29 — Marking data sheet for subsea hydraulic choke actuators

Marking	Location
Manufacturer	Nameplate
Model number	Nameplate
Maximum operating hydraulic pressure – MPa (psi)	Nameplate and cylinder
Input torque rating (maximum) - Nm (ft-lbs)	Nameplate
Maximum output torque - Nm (ft-lbs)	Nameplate
Number of steps to open	Nameplate
ISO requirements	Nameplate
— PSL level	
— Temperature range	
— ISO 13628-4	
— Date (month/year)	
Serial number (if required)	Nameplate
Part number	Nameplate
Manual override direction to open	Nameplate

Table 30 — Marking for subsea choke and actuator assembly

Marking	Application
Assembler's name or trademark	Nameplate
ISO 13628-4	Nameplate
Assembly serial or identification number	Nameplate
Rated water depth	Nameplate

## 7.22.2 Design

### 7.22.2.1 General design requirements

#### 7.22.2.1.1 Loads

As a minimum, the following loads shall, where applicable, be considered when designing miscellaneous equipment:

- suspended weight;
- control pressure;
- well pressure;
- hydrostatic pressure;
- handling loads;
- impact.

#### 7.22.2.1.2 Operating pressure

Tools operated by hydraulic pressure shall be rated in accordance with the pressure ratings specified by the manufacturer.

#### 7.22.2.2 Remote guideline establishment and re-establishment tools

Guideline establishment/re-establishment tools are used to attach cables to guide posts of subsea completion structures. Any such tool that uses the relative guide post positions shall be designed based on the spacing described in 8.3.2.2.

#### 7.22.2.3 Test stands and fixtures

##### 7.22.2.3.1 General

Test stands and fixtures (including jigs) are used at the point of assembly or installation to verify the interface and functional operation, load and pressure capacity, and interchangeability of the equipment being installed. They may also serve as the shipping skids for transporting equipment offshore. Test stands and fixtures used only at the manufacturer's facilities are outside the scope of this part of ISO 13628.

##### 7.22.2.3.2 Accuracy of test equipment

Where test equipment is used to simulate a mating component for testing the assembly of interest, it shall be made to the same dimensions and tolerances at all interfaces as the simulated component.

##### 7.22.2.3.3 Loads during testing/handling and assembly

Design of test stands and fixtures shall consider assembly and handling loads as well as test loads.

##### 7.22.2.3.4 Test stumps

Test stumps simulate the profiles of the wellhead, tree re-entry interface, etc., to facilitate pressure testing of the tree, tree running tool, tree cap, etc., and to position orienting joints relative to the BOP stack. They may also contain hydraulic couplers to facilitate testing of the controls functions. Stab pockets may be machined directly in the stump or, for tree testing, may be contained in a dummy tubing hanger. When specified, the tree test stump shall accept a real tubing hanger. Test ports shall communicate with the individual bores of the test stumps to facilitate pressure testing. The benefits of piping all test ports back to a common manifold with isolation test valves shall be examined. Guidance provided by the test stumps shall simulate the requirements of the actual equipment being tested.

##### 7.22.2.3.5 Equipment used for shipping

Test skids, etc. used for shipping equipment offshore shall provide protection to the equipment during handling and transportation. Sea fastenings shall be designed to take all the static and accelerated loading conditions due to roll, pitch and heave of the vessel in the locality where it will be transported and should be suitable for securing the assembly to the rig and rig skids.

#### 7.22.3 Materials

Materials shall conform to 5.1 and 5.2 if subjected to well-fluid contact. Selection of other materials shall consider encountered fluids and galvanic compatibility, as well as mechanical properties. Seal surfaces that engage metal-to-metal seals shall be inlaid with a corrosion-resistant material that is compatible with the well fluids, seawater, etc. Overlays are not required if the base material is compatible with well fluids, seawater, etc.

For forged material used for pressure-containing and high-load-bearing parts, forging practices, heat treatment and test coupon (QTC or prolongation) requirements should meet those of API RP 6HT. In addition, the test coupon shall accompany the material it qualifies through all thermal processing, excluding stress relief.

#### 7.22.4 Testing

All components subject to pressure shall be tested to one and one-half times their RWP unless a different test pressure is required elsewhere in this part of ISO 13628. The test procedure shall conform to 5.4. Fit and functional testing shall be performed in accordance with the manufacturer's written specification for any tool that has an interface with equipment that is being installed subsea.

#### 7.22.5 Marking

Tools shall be permanently marked following the methods and requirements of 5.5. In addition, all tools that are not a permanent part of a subsea assembly shall be marked with the date of manufacture, applicable load ratings and part number.

## 8 Specific requirements — Subsea wellhead

### 8.1 General

**8.1.1** Clause 8 describes subsea wellhead systems that are normally run from floating drilling rigs. It establishes standards and specifications for this equipment. The subsea wellhead system supports and seals casing strings. It also supports the BOP stack during drilling, and the subsea tree and possibly the tubing hanger after completion. The subsea wellhead system is installed at or near the mudline.

**8.1.2** All pressure-containing and pressure-controlling parts included as part of the subsea wellhead equipment shall be designed to meet all of the requirements of ISO 15156 (all parts). These parts include

- wellhead housing;
- casing hanger bodies;
- annulus seal assemblies.

**8.1.3** The following parts or features are excluded from ISO 15156 (all parts) requirements:

- lock rings;
- load rings;
- load shoulders;
- suspension equipment;
- bore protectors and wear bushings.

**8.1.4** Additionally, life-of-well parameters shall be included in design considerations, including contributions from the drilling, testing, completion and production phases of well operations. While the codes governing the structural capacity of the wellhead system ensure reliability in the short-term, this is insufficient to ensure integrity for long-term production applications.

Further evaluation is required for the following issues, which affect long-term reliability:

- cyclic external loads;
- internal pressure cycle loads and displacements;
- thermal loads and gradients;
- general corrosion;
- stress corrosion cracking (due to hydrogen, H<sub>2</sub>S or chlorides).

These issues may require assessment by fatigue analysis, fracture mechanics evaluation, structural evaluation due to thermal loading, or structural evaluation with reduced capacity due to corrosion allowance. While cathodic protection systems are often utilized for production wells to reduce corrosion, this can increase the possibility for stress corrosion cracking due to the release of free hydrogen.

## 8.2 Temporary guidebase

### 8.2.1 General

The TGB when used provides a guide template for drilling the conductor hole and stabbing the conductor pipe. It compensates for misalignment from irregular ocean-bottom conditions and may provide a support base for the PGB. If used together with a PGB, a cone-and-gimbal arrangement compensates for angular misalignment between the TGB and the PGB due to the seabed topography and the verticality of the well. For guideline systems, it also establishes the initial anchor point for the guidelines. It may also include a provision for suspending a foundation sleeve to support unconsolidated surface soils. The TGB might not always be used, as in the case of template completions or satellite structure (foundation and/or protective structure) completions.

A TGB may also serve as a mudmat if the drilling of the conductor hole is performed by jetting operations. In this instance, it serves a physical stop to assure that the wellhead stays a fixed distance above the sea floor and subsequently serves as a temporary foundation, enhancing the bearing load capacity in unconsolidated or under-consolidated surface soils. The increased bearing capacity is used to support the weight of the conductor (preventing it from sinking) until the next section of hole is drilled and the surface pipe is sufficiently landed and cemented in place.

Provisions for the design and associated load testing shall conform to the requirements in 5.1.3.6.

### 8.2.2 Design

#### 8.2.2.1 Loads

The following loads shall be considered and documented by the manufacturer when designing the TGB:

- ballast;
- guideline tension;
- weight of conductor pipe;
- weight of PGB assembly;
- Hanging or suspension loads;
- soil reaction.

The TGB shall be capable of supporting, as a minimum, a static load of 780 kN (175 000 lbf) on the interface with the PGB while the TGB is supported at four locations, equally spaced  $90^{\circ} \pm 2^{\circ}$  apart and a minimum of 1 575 mm (62 in) from the centre (radial measure). Recommendations for lifting pad eyes are outlined in Annex K.

#### 8.2.2.2 Dimensions

The requirements for dimensions are as follows.

- a) The TGB minimum bearing area shall be 7 m<sup>2</sup> (75 ft<sup>2</sup>). This area may be augmented with weld-on or bolt-on extensions to compensate for soil strengths and anticipated loads.
- b) TGB should pass through a 5 m (16,4 ft) square opening or as specified by the manufacturer.
- c) TGB shall provide four guideline anchor points in position to match the guide posts on the PGB.

- d) Together with the PGB, the TGB shall allow a minimum angular misalignment of 5° between the conductor pipe and the temporary guidebase.
- e) TGB shall provide a minimum storage volume of 2 m<sup>3</sup> (70,6 ft<sup>3</sup>) for ballast material.

### 8.3 Permanent guidebase

#### 8.3.1 General

The PGB attaches to the conductor housing and provides guidance for the drilling and completion equipment (surface casing, BOP, production tree, running tools). The PGB provides entry into the well prior to installation of the wellhead housing and BOP. After the wellhead housing installation, the PGB provides guidance of the BOP, subsea tree or tubing head onto the wellhead housing using guideline or guidelineless methods. It may establish structural support and final alignment for the wellhead system and provides a seat and lock down for the conductor housing. PGBs can be built as a single piece or split into two pieces to ease handling and installation. Optionally, they may include provisions for conductor-pipe hang-off, retrieval and to transfer flowline loads. The PGB may be retrieved after drilling is complete and replaced by a PGB carrying flowline connection/manifold equipment. Alternatively, the PGB installed for drilling may carry flowline connection/manifold equipment. In either case, the equipment shall not interfere with the BOP stack installation. Consideration shall be given to required ROV access and cuttings disposal.

A PGB using a re-entry funnel for guidelineless equipment guidance is often referred to as a guidelineless re-entry assembly or GRA. The re-entry funnel may be on the GRA housing looking upward (funnel-up) or may be configured in concert with matching funnel equipment on the subsea equipment subsequently landed in the GRA (funnel down). Funnel geometry usually involves one (or more) diagonal cone(s) and a centre cylinder frame to provide alignment between mating components/structures. The outermost diameter of the diagonal cone should be no less than 1,5 times the diameter of the component it is capturing. The diagonal cone's angle should be no shallower than 40° with respect to horizontal. Typically the cone angle is 45°. Once captured, the GRA's cone(s) and inner cylinder should be designed to allow for equipment re-entry at tilt angles up to 3° from vertical in any orientation, and subsequently assist in righting the captured component to vertical.

Portions of the re-entry cone may be scalloped out to accommodate the guidelineless re-entry of adjacent equipment whose capture funnel can intersect with the main funnel(s) because of space constraints. This is acceptable, although it takes away from the re-entry properties of the funnel in the scalloped-out area. Its practice should be carried out with sound engineering judgement comparing operational limits lost versus size and weight gained. Ideally, scalloped funnels should be minimized or covered wherever practical.

GRAs also may include provisions for conductor-pipe hang-off. If so, since GRAs are typically cylindrical and conical in nature, horizontal resting pads or a beam structure should be incorporated in the frame's design to provide a sound flat surface that can firmly sit on spider beams.

When spatial orientation is required, the funnel-up funnels and capture equipment may also feature Y-slots and orienting pins. The upper portion of the Y-slot should be wide enough to capture mating pins within  $\pm 7,5^\circ$  of true orientation. The Y-slot should then taper down to a width commensurate with the pin to provide orientation to within  $\pm 0,5^\circ$  (similar to the angular orientation provided by guide posts and funnels). Typically, there are two or four orienting pins, each with a minimum diameter of 101,6 mm (4,00 in) in diameter. Other orientation methods, such as orienting helixes or indexing devices (ratchets, etc.) are also acceptable. Whatever the orienting method, it is necessary that the design allow for the 3° tilt re-entry requirement with enough play to accommodate this gimbaling effect unimpeded.

Funnel-down funnels do not easily accommodate Y-slots and orienting pins. Alternate orientation methods such as orientation helixes or indexing devices may be required.

PGB/GRAs should not impede the flowby required for cementing, jetting ops., etc.

Provisions for design and associated load testing shall conform to the requirements in 5.1.3.6.

### 8.3.2 Design

#### 8.3.2.1 Loads

The following loads shall be considered and documented by the manufacturer when designing the PGB (see Figures 11 and 12):

- conductor pipe weight;
- conductor housing weight;
- hanging loads;
- jetting-string weight when supported on the spider beams;
- guideline tension;
- flowline pull-in, connection or installation loads;
- annulus access connection loads;
- environmental;
- reaction for TGB;
- installation loads (including conductor hang-off on spider beams);
- snagging loads;
- BOP loads;
- sea fastening (when supported on spider beams).

The PGB or GRA shall be capable of supporting, as a minimum, a static load of 780 kN (175 000 lbf) on the interface with the conductor housing while the PGB is supported at four locations equally spaced  $90^\circ \pm 2^\circ$  apart and a minimum of 1 525 mm (60 in) from the centre (radial measure).

#### 8.3.2.2 PGB dimensions

The PGB dimensional requirements are as follows.

- a) The dimensions of the PGB shall conform to the dimensions shown in Figure 9 a).
- b) The guide posts shall be fabricated of 219 mm (8 5/8 in) OD pipe or tubulars. Guide post funnels are typically fabricated from 273 mm OD  $\times$  13 mm wall (10 3/4 in OD  $\times$  0,5 in wall) pipe or tubulars.
- c) The length of the guide post [item 1 in Figure 9 a)] shall be 2 440 mm (8 ft) minimum for drilling purposes. The guide posts may be extended to provide guidance for the subsea tree, LWRP and/or tree cap.

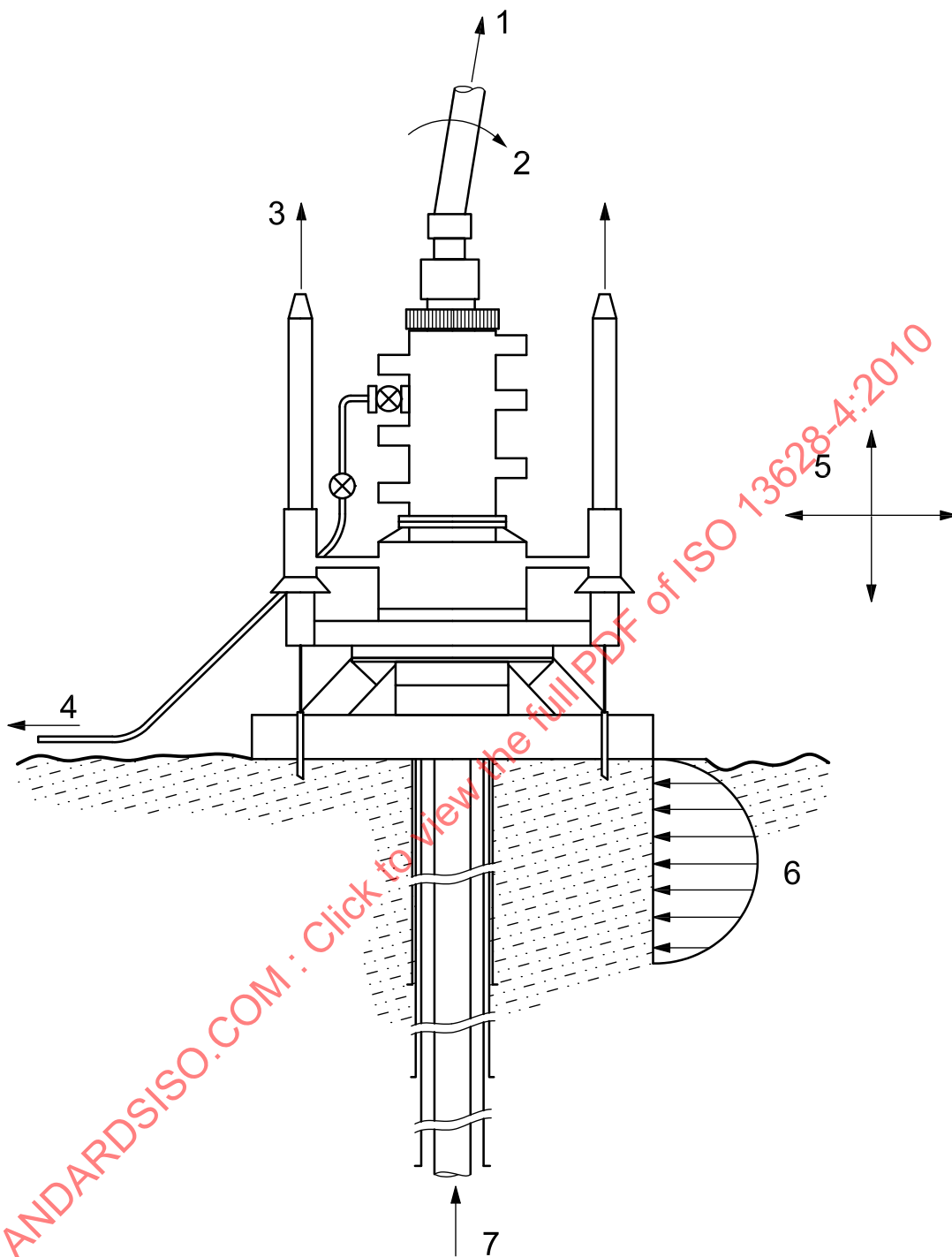

**Key**

- |                        |   |
|------------------------|---|
| 1 riser tension        | 5 environmental (current, wave, action, etc.) |
| 2 applied moments      | 6 soil reaction                               |
| 3 guideline tension    | 7 thermal                                     |
| 4 flow line connection |   |

**Figure 11 — External loads on a subsea tree and wellhead**

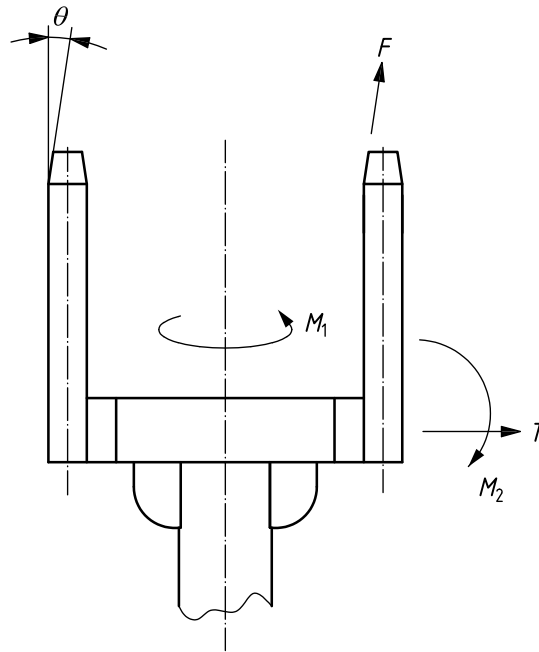

**Key**

- $F$  force from guideline
- $M_1$  torsional bending moment
- $M_2$  bending moment
- $T$  tension
- $\theta$  angle at which guideline force acts

**Figure 12 — Permanent guidebase (PGB) loads**

**8.3.2.3 GRA dimensions**

The re-entry funnel may be on the GRA housing looking upward (funnel-up) or may be configured in concert with matching funnel equipment on the subsea equipment subsequently landed in the GRA (funnel down). Funnel geometry usually involves one (or more) diagonal cone(s) and a centre cylinder frame to provide alignment between mating components/structures. The outermost diameter of the diagonal cone should be no less than 1,5 times the diameter of the component it is capturing. The diagonal cone's angle should be no shallower than 40° with respect to horizontal. Typically, the cone angle is 45°. Once captured, the GRAs cone(s) and inner cylinder should be designed to allow for equipment re-entry at tilt angles up to 3° from vertical in any orientation, and subsequently assist in righting the captured component to vertical.

Portions of the re-entry cone may be scalloped out to accommodate the guidelineless re-entry of adjacent equipment whose capture funnel can intersect with the main funnel(s) because of space constraints. This is acceptable, although it takes away from the re-entry properties of the funnel in the scalloped-out area. Its practice should be carried out with sound engineering judgement comparing operational limits lost versus size and weight gained. Ideally, scalloped funnels should be minimized or covered wherever practical.

GRAs also may include provisions for conductor-pipe hang-off. If so, since GRAs are typically cylindrical and conical in nature, horizontal resting pads or a beam structure should be incorporated in the frame's design to provide a sound, flat surface that can firmly sit on spider beams.

See 7.15.2.1 when spatial orientation is required.



### 8.3.2.4 Functional requirements

The functional requirements are as follows.

- a) When used with the TGB, the PGB (GRA) shall allow a minimum angular misalignment of 5° between a 762 mm (30 in) conductor pipe and the TGB. For other conductor pipe sizes, the manufacturer shall document the misalignment capability.
- b) Guide posts shall be field-replaceable without welding, using either diver, ROV or remote tooling. The locking mechanism should not inadvertently release due to snagging wires, cables, etc.
- c) Guide posts can be either slotted or non-slotted. Slotted guide posts are required when used with a TGB, if the guidelines are not disconnected from the TGB. For slotted guide posts, provisions shall be made to insert guidelines of at least 19 mm (3/4 in) OD into the post with retainers at the top and at or near the bottom of the post.
- d) Provisions shall be made to attach guidelines to the top of the guide posts. The guidelines shall be capable of being released and re-established. This may be by the use of diver, ROV or remote tooling.
- e) The PGB (GRA) should contain a feature that facilitates the orientation between the PGB (GRA) and the conductor housing. The orientation device may allow the installation of the guidebase in multiple-orientation positions to suit rig heading. The orientation device may also provide an anti-rotation feature to resist the loads defined in 8.3.2.1.
- f) When specified, the PGB (GRA) shall contain grouting funnels for cement top-up.
- g) When specified, the PGB (GRA) shall contain seals and a structure to deflect seabed and cement-port gases (which can form hydrates) from entering the BOP, subsea tree or tubing head connector.
- h) Guidelineless equipment shall not reduce the release angle of the BOP, tree or tubing head connector. The guidelineless equipment shall allow installation and retrieval of equipment up to a 3° angle without damaging the wellhead seal surfaces or contacting installed wellhead gaskets.
- i) A positive lock or load shoulder should be used to hang off the conductor in the PGB (GRA).
- j) Dedicated lift points shall be provided.
- k) PGB (GRA) should not impede flowby.
- l) PGB (GRA) shall be designed to be run with a conductor housing or independently on a running tool.

## 8.4 Conductor housing

### 8.4.1 General

The conductor housing attaches to the top of the conductor pipe to form the basic foundation of a subsea well. The housing typically has a means of attaching to the PGB (GRA), which can also provide a means for anti-rotation between the PGB (GRA) and the conductor housing.

A typical conductor housing profile is shown in Figure 13. The internal profile of the conductor housing includes a landing shoulder suitable for supporting the wellhead housing and the loads imposed during the drilling, completion and workover operations. Running tool preparations should also be a part of the internal housing profile. The external profile of the conductor housing shall be compatible with supporting the conductor pipe in the rotary table and/or at the spider beams in the moonpool. Cement return passageways may be incorporated in the conductor housing/PGB (GRA) assembly to allow directing cement and mud returns either below the PGB (GRA) or through ports in the PGB (GRA).

Provision for seals against hydrates, etc., may also be incorporated in the conductor housing when required.

Other enhancements to the conductor housing, such as cuttings disposal, cement top-off, rigid lockdown, etc., may be included. An intermediate casing string may also be hung off inside the conductor housing prior to the wellhead casing string. Facilities for landing the intermediate casing string can be required for the wellhead casing string. Methods of annular shut-off may be used on flowby holes to avoid hydrate migration from the annulus between the conductor pipe and the wellhead casing string.

## 8.4.2 Design

### 8.4.2.1 Loads

The following loads shall be considered and documented by the manufacturer when designing the conductor housing; see 8.2.2.1:

- wellhead loads;
- hanging/hangoff loads while suspended in the moonpool;
- riser forces;
- PGB loads (see Figures 11 and 12);
- environmental loads;
- snag loads;
- pressure loads;
- thermal loads.

The interface between the conductor housing and the PGB shall be designed for a minimum rated load of 780 kN (175 000 lbf).

### 8.4.2.2 Dimensions

The requirements for dimensions are as follows:

- a) The following dimensions typically apply to 762 mm (30 in) through 914,4 mm (36 in) conductor housings:
  - minimum ID: 665 mm (26,20 in);
  - maximum OD: 950 mm (37,40 in).
- b) The conductor housing is not limited to 762 mm (30 in) through 914,4 mm (36 in) sizes. Rotary-table dimensions, seabed soil conditions and foundation loads should be considered when selecting the outside diameter of the conductor housing. The drill-bit gauge diameter used for the next string of casing plus 3 mm (1/8 in) clearance should be considered when selecting the internal diameter of the conductor housing.

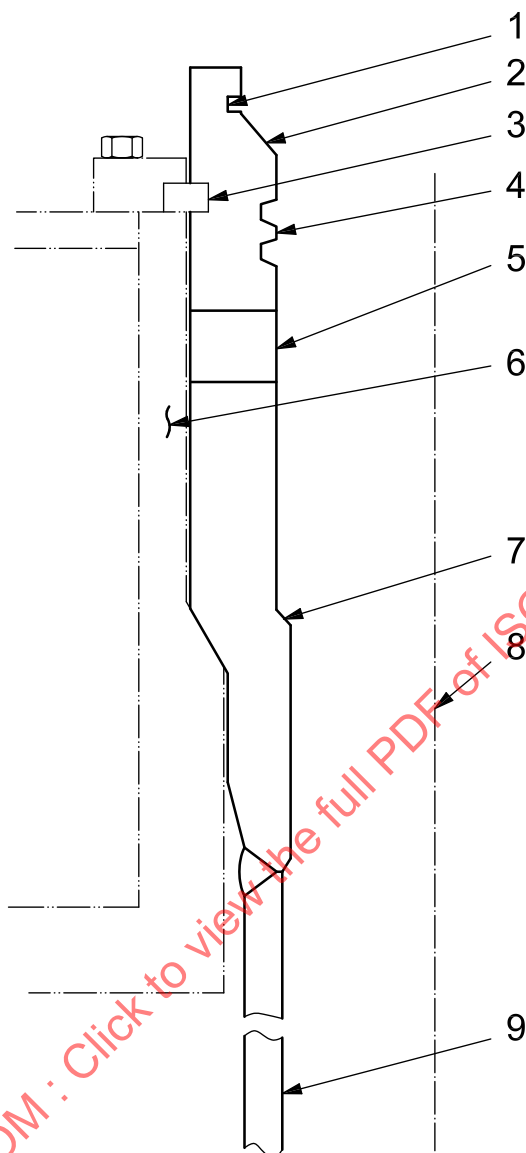
**Key**

- |  |                       |
|--|-----------------------|
| 1 wellhead lock down                             | 6 permanent guidebase |
| 2 landing shoulder for wellhead                  | 7 landing shoulder    |
| 3 permanent guidebase attachment                 | 8 centreline          |
| 4 running tool and tieback connector preparation | 9 conductor casing    |
| 5 cement port (optional)                         |                       |

**Figure 13 — Typical conductor housing****8.4.2.3 Bottom connection**

The bottom connection includes all the weldments (extensions, reducers, swages, etc.) between the conductor housing and the conductor pipe.

If the bottom end connection is being welded, it shall be prepared for a full-penetration butt-weld.

The user shall specify the allowable SCF, maximum defect size and NDE inspection criteria when fatigue criteria are identified.

#### 8.4.2.4 Pup joint

The conductor housing may have a pup joint that is factory-welded on to ease field installation.

#### 8.4.2.5 Handling/support

Handling and support lugs may be supplied for hang-off during installation and for handling during shipping and installation. The maximum rotary table hang-off height for tool-joint make-up should be specified by the user.

#### 8.4.3 Impact testing

Impact testing is not required.

#### 8.4.4 Testing

Validation testing shall be in accordance with 5.1.7. No factory acceptance testing is required.

### 8.5 Wellhead housing

#### 8.5.1 General

The wellhead housing lands inside the conductor housing. It provides pressure integrity for the well, suspends the surface and subsequent casing strings and tubing hanger and resists against external loads. The BOP stack or subsea tree attaches and seals to the top of the wellhead housing using a compatible wellhead connector and gasket. The wellhead housing shall accept tubing hangers or tubing hanger adapter. The standard system sizes are given in Table 15. Figure 14 shows profiles of two typical wellhead housings.

#### 8.5.2 Design

##### 8.5.2.1 Loads

As a minimum, the following loads shall be considered and documented by the manufacturer when designing the wellhead housing:

- riser forces (drilling, production and workover);
- BOP loads;
- subsea tree loads;
- pressure (internal and external);
- radial loads;
- thermal loads;
- environmental loads;
- flowline loads;
- suspended-casing loads;
- conductor-housing reactions;
- tubing-hanger reactions;
- hydraulic connector loads;
- fatigue loading.

## 8.5.2.2 Connections

### 8.5.2.2.1 Top connection

The top connection should be of a hub or mandrel type (see Figure 14) as specified by the user. The gasket profiles shall be manufactured from or inlaid with corrosion-resistant material as specified in 5.3.3. The gasket profile shall provide a primary and a secondary gasket seal area.

### 8.5.2.2.2 Bottom connection

The high-pressure housing attaches to the top of the surface casing to form the basic foundation of a subsea well.

If the bottom connection is being welded, it shall be prepared for a full-penetration butt-weld.

The user shall specify the allowable SCF, maximum defect size and NDE inspection criteria when fatigue criteria are identified.

### 8.5.2.2.3 Pup joint

The wellhead housing may have a pup joint that is factory-welded on to ease field installation.

### 8.5.2.2.4 Body penetrations

Body penetrations within the housing pressure boundary are not permitted.

## 8.5.3 Dimensions

The dimensional requirements are as follows.

- a) The minimum vertical bore of the wellhead housing shall be as given in Table 15.
- b) Dimensions of the wellhead pressure boundary (see Figure 14) shall be in accordance with the manufacturer's written specification.

## 8.5.4 Rated working pressure

The RWP for the wellhead housing pressure boundary (see Figure 14) shall be 34,5 MPa (5 000 psi), 69 MPa (10 000 psi) or 103,5 MPa (15 000 psi). Selection of the rated working pressure should consider the maximum expected SCSSV operating pressure (see 5.1.2.1.1).

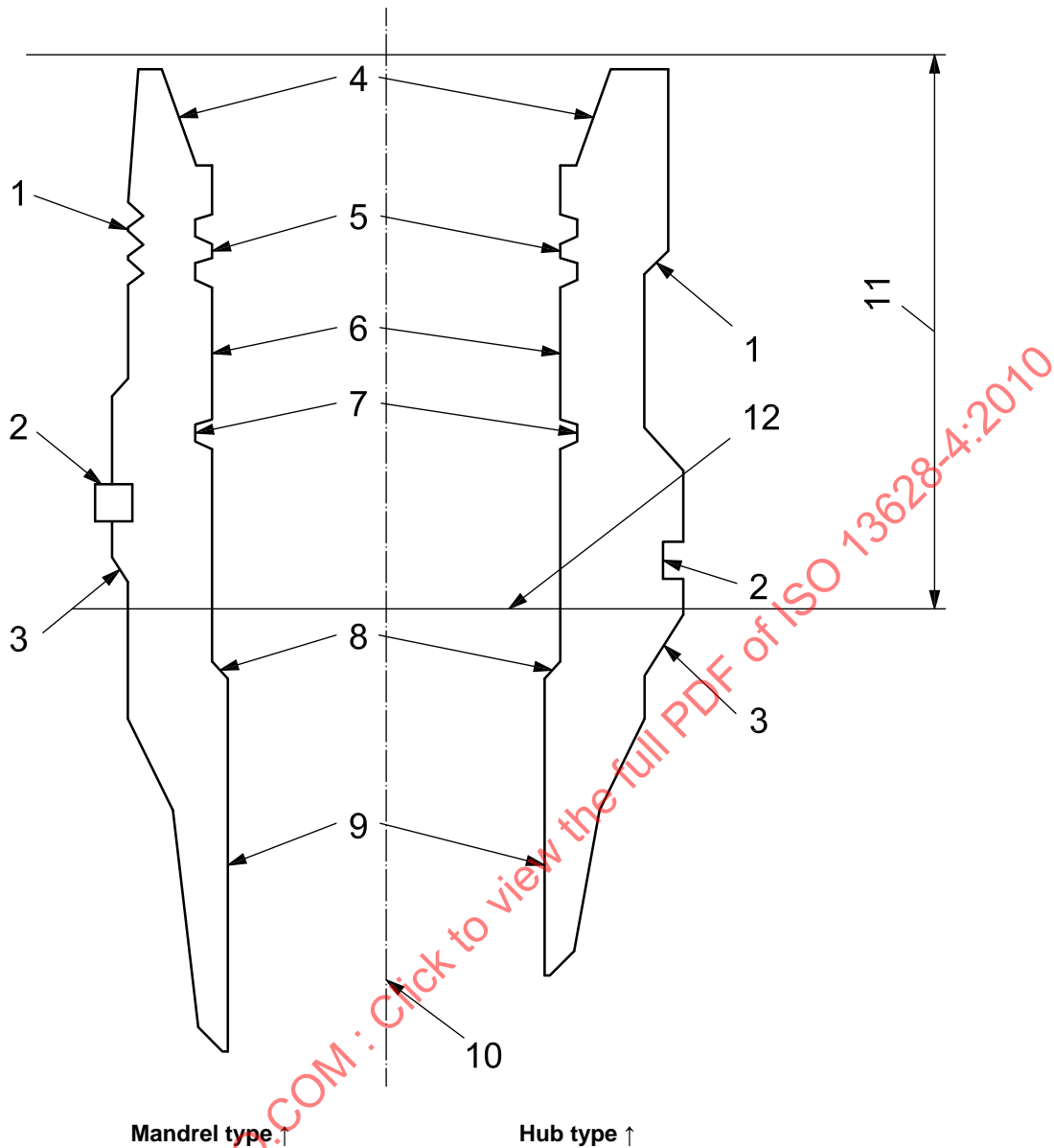

Mandrel type ↓	Hub type ↑
1 connector profile	7 hanger lock-down profile
2 housing lock-down	8 hanger landing shoulder
3 landing shoulder	9 minimum bore
4 gasket profile	10 centreline
5 running tool preparation	11 wellhead housing pressure boundary
6 casing hanger/pack-off seal area	12 position of lowermost casing hanger seal assembly

**Figure 14 — Typical wellhead housings**

**8.5.5 Testing**

**8.5.5.1 Factory acceptance testing**

All wellhead housings shall be hydrostatically tested prior to shipment from the manufacturer's facility. The hydrostatic test is performed to verify the pressure integrity of the housing pressure boundary. All wellhead housings shall be tested to the requirements of ISO 10423, PSL 3 or PSL 3G.

The hydrostatic body test pressure shall be determined from the housing rated working pressure (see Table 31). The hydrostatic body test pressure shall not be less than the values given in Table 31.

Wellhead housings shall show no visible leakage or visible bubbles in the water bath during each pressure holding period. Any permanent deformation of the housing, after hydrostatic testing is complete, shall not adversely affect the function of the casing hangers, packoffs, gaskets, connectors or other subsea equipment. Housing should show no deformation, within tolerances, after hydrostatic testing is complete.

**Table 31 — Test pressure**

Rated working pressure		Hydrostatic body test pressure	
MPa	(psi)	MPa	(psi)
34,5	(5 000)	51,8	(7 500)
69,0	(10 000)	103,5	(15 000)
103,5	(15 000)	155,2	(22 500)

## 8.6 Casing hangers

### 8.6.1 General

The subsea casing hanger is installed on top of each casing string and supports the string when landed in the wellhead housing. It is configured to run through the drilling riser and subsea BOP stack, land in the subsea wellhead, and support the required casing load. It shall have provisions for an annulus seal assembly and support loads generated by BOP test pressures above the hanger and loads due to subsequent casing strings. Means shall be provided to transfer casing load and test pressure load to the wellhead housing or to the previous casing hanger.

A pup joint of casing should be installed on the hanger in the shop. This reduces the risk of damage during handling and later make-up in the field. API threaded connections should follow ISO 10426 (all parts) for make-up requirements when connecting the pup joint to the hanger. Sufficient length shall be provided on both the hanger and the pup joint for tonging. Proprietary thread connection should be made up in accordance with the manufacturer's written specification.

NOTE For the purposes of this provision, API Spec 5CT is equivalent to ISO 10426 (all parts).

Subsea casing hangers shall be treated as pressure-controlling equipment as defined in ISO 10423. In some cases, a casing string may be suspended in a submudline landing ring that is included as part of another casing string below the wellhead. Submudline casing hangers suspended from submudline landing rings shall meet the requirements of 8.14.

A lockdown mechanism, if required, is used to limit or restrict movement of the casing hanger. This mechanism may be integral to the seal assembly or run as part of an independent assembly.

### 8.6.2 Design

#### 8.6.2.1 Loads

As a minimum, the following loads shall be considered and documented by the manufacturer when designing casing hangers (including lockdown mechanisms, if used):

- suspended weight;
- overpull;

- pressure, internal and external;
- thermal;
- torsional;
- radial;
- impact.

**8.6.2.2 Threaded connections**

The type of casing threads on the hanger shall be specified by the user. Identification markings shall conform to ISO 10423.

Casing threads should be coated to prevent galling when required by the thread type or material and should be specified by the manufacturer.

**8.6.2.3 Vertical bore**

**8.6.2.3.1 Full opening vertical bore**

The minimum vertical bores for full-opening or full-bore casing hangers shall be as given in Table 32. Equipment conforming to this requirement shall be referred to as having full-opening bores.

**8.6.2.3.2 Reduced opening vertical bore**

Reduced vertical bores may also be supplied.

**Table 32 — Minimum vertical bore sizes for casing hangers and wear bushings**

Casing OD		Minimum vertical bore	
mm	(in)	mm	(in)
178	(7)	153	(6,03)
194	(7 5/8)	172	(6,78)
219	(8 5/8)	195	(7,66)
244	(9 5/8)	217	(8,53)
251	(9 7/8)	217	(8,53)
273	(10 3/4)	242	(9,53)
298	(11 3/4)	271	(10,66)
340	(13 3/8)	312	(12,28)
346	(13 5/8)	312	(12,28)
356	(14)	312	(12,28)
406	(16)	376	(14,81)
457	(18)	420	(16,55)
508	(20)	467	(17,58)



#### 8.6.2.4 Outside profile

The outside profile shall be in accordance with the manufacturer's written specification.

#### 8.6.2.5 Casing hanger ratings

The load and pressure ratings for casing hangers can be a function of the tubular grade of material and wall section as well as the wellhead equipment in which it is installed. Manufacturers shall determine and document the load/pressure ratings for casing hangers as defined below.

##### a) Hanging capacity:

The manufacturer's stated hanging capacity rating for a casing hanger includes the casing thread (normally a female thread) cut into the hanger body.

##### b) Pressure rating:

The manufacturer's stated pressure rating for a casing hanger includes the hanger body and the casing thread (normally a female thread) cut into the lower end of the hanger.

NOTE The user is responsible for determining the working pressure of a given weight and grade of casing and its hanging capacity.

##### c) BOP test pressure:

The BOP test pressure rating for a casing hanger is the maximum pressure that may be applied to the upper portion of the hanger body and to the annulus seal assembly. This rating specifically excludes the casing connection at the lower end of the casing hanger.

##### d) Support capacity:

The manufacturer's stated support capacity is the rated weight that the casing hanger(s) are capable of transferring to the wellhead housing or previous casing hanger(s). The effects of full rated internal working pressure shall be included.

#### 8.6.2.6 Flowby area

An external flowby area allows for returns to flow past the hanger during cementing operations and is designed to minimize pressure drop, while passing as large a particle size as possible. Casing hanger minimum flowby areas and maximum particle size shall be documented by the manufacturer and maintained for each casing hanger assembly.

### 8.6.3 Testing

#### 8.6.3.1 Validation testing

Validation testing of subsea wellhead casing hangers shall conform to 5.1.7. Validation testing for internal pressure shall be performed to verify the structural integrity of the hanger and shall be independent of the casing grade and thread.

#### 8.6.3.2 Factory acceptance testing

It is not necessary that the factory acceptance testing of subsea wellhead casing hangers include a hygrometer. A dimensional check or drift test shall be performed on the hanger to verify the minimum vertical bore (see Table 32) is in accordance with the manufacturer's specification.

## 8.7 Annulus seal assemblies

### 8.7.1 General

Annulus seal assemblies provide pressure isolation between each casing hanger and the wellhead housing. They may be run simultaneously with the subsea casing hanger, or separately. Annulus seal assemblies are actuated by various methods, including torque, weight and/or hydraulic pressure. The production annulus seal assembly should be isolated from the production annulus by a seal sleeve or constructed from suitable materials if the potential for corrosion or loss of inhibited fluids exists.

Subsea annulus seal assemblies shall be treated as pressure-controlling equipment as defined in ISO 10423.

### 8.7.2 Design

#### 8.7.2.1 Loads

The following loads shall be considered and documented by the manufacturer when designing the annulus seal assemblies:

- setting loads;
- thermal loads;
- pressure loads;
- releasing and/or retrieval loads.

#### 8.7.2.2 Rated working pressure

The rated working pressure from above for the annulus seal assembly shall be equal to or greater than the rated working pressure of the casing hanger [see 8.6.2.5 b)]. The manufacturer shall specify the rated working pressure from below if it is different than the rated working pressure from above.

#### 8.7.2.3 Outside profile

The outside profile shall be in accordance with the manufacturer's written specification.

#### 8.7.2.4 Lockdown

The annulus seal assembly may be locked to the casing hanger and/or wellhead using a lock mechanism that allows retrieval without damage to the seal surfaces in the event of seal failure. Lockdown mechanisms may be rigid or allow some casing hanger/annulus seal movement. The requirement for an additional lockdown device or limiting device during production should be considered based on expected loads (see 8.7.2.1 and 8.8) and annulus seal design.

### 8.7.3 Emergency annulus seal assemblies

Emergency annulus seal assemblies that position the seal in a different area or use a different seal mechanism shall be designed. The design shall meet all requirements given in 8.7.2.

### 8.7.4 Testing

#### 8.7.4.1 Validation testing

Validation testing of annulus seal assembly and emergency annulus seal assembly shall conform to 5.1.7.

#### 8.7.4.2 Factory acceptance testing

Factory acceptance testing is not required for either the annulus seal assembly or emergency annulus seal assembly.

### 8.8 Casing hanger lockdown bushing

#### 8.8.1 General

A casing hanger lockdown bushing may be installed on top of the uppermost casing hanger in the subsea wellhead housing to provide one or more of the following functions:

- rigidize and prevent vertical movement of the casing hanger and annulus seal assembly, thereby improving the long-term sealing integrity of the annulus seal assembly;
- resist greater upward loads than the lockdown device on the annulus seal assembly is capable of resisting, such as thermal expansion loads of the production casing string;
- isolate the uppermost annulus seal assembly from the annulus between the production tubing and the production casing hanger;
- provide a sealing interface to a subsea tree, tubing hanger or tubing head;
- provide a lockdown profile for the tubing hanger.

Lockdown bushings shall be treated as pressure-controlling equipment as defined in ISO 10423.

The lockdown bushing may be configured to run in open water and/or through the drilling/completion riser and subsea BOP. The lockdown bushing shall be designed such that it is retrievable through the drilling/completion riser and subsea BOP.

The requirement for using a lockdown bushing is dependent on the design of the casing hanger and annulus seal assembly, the project specific loading conditions and the interface to the subsea tree, tubing hanger or tubing head. When the wellhead and tree systems are provided by different manufacturers, the user is responsible for interfacing with the subsea wellhead and tree system manufacturers to determine whether a lockdown bushing is required.

#### 8.8.2 Design

##### 8.8.2.1 Loads

As a minimum, the following loads shall be considered and documented by the manufacturer when designing lockdown bushings:

- setting loads;
- overpull;
- pressure, internal and external (including casing-expansion loads);
- thermal (including casing-expansion loads);
- torsional;
- impact;
- releasing and/or retrieval loads;
- tubing hanger pressure end loads;

- tubing string suspension loads;
- BOP test loads.

#### 8.8.2.2 Vertical bore

The minimum vertical bore through the lockdown bushing shall be equal to or greater than the minimum drift diameter of the production casing hanger or production casing string, whichever is smaller.

#### 8.8.2.3 Outside profile

The outside profile shall be in accordance with the manufacturer's written specification.

#### 8.8.2.4 Vertical load capacity

The manufacturer shall determine and document the vertical lockdown load capacity of the lockdown bushing.

The manufacturer shall determine and document the maximum downward load capacity of the lockdown bushing, as can be required to support a tubing hanger or BOP test tool. Tubing suspension loads and pressure end loads shall be considered.

#### 8.8.2.5 Pressure rating

The manufacturer's stated internal pressure rating for the lockdown bushing shall meet or exceed the pressure rating of the production-casing hanger and production-casing string, whichever is smaller. The internal pressure rating should be equal to the pressure rating of the subsea tree system, if possible.

The manufacturer shall determine and document the external pressure rating of the lockdown bushing. The external pressure rating shall consider the hydrostatic head of sea water and the test pressure that will be used subsea to verify the sealing integrity of the gasket between the wellhead housing and the subsea tree.

### 8.8.3 Testing

#### 8.8.3.1 Validation testing

Validation testing of casing hanger lockdown bushing shall conform to 5.1.7. Validation testing for internal and external pressure and upward and downward load capacity shall be performed to verify the structural integrity of the lockdown bushing.

#### 8.8.3.2 Factory acceptance testing

Factory acceptance testing of lockdown bushing shall include internal and external pressure hydrostatic tests. A dimensional check or drift test shall be performed on the hanger to verify the minimum vertical bore is in accordance with the manufacturer's specification.

## 8.9 Bore protectors and wear bushings

### 8.9.1 General

A bore protector protects annulus seal assembly sealing surfaces inside the wellhead housing before casing hangers are installed. After a casing hanger is run, a correspondingly sized wear bushing is installed to protect the remaining annular sealing surfaces and the previously installed annular seal assemblies and casing hangers. They are generally not pressure-retaining devices. However, wear bushings may be designed to support BOP stack pressure test loading.

## 8.9.2 Design

### 8.9.2.1 Loads

The following loads shall be considered and documented by the manufacturer when designing the bore protectors or wear bushings:

- BOP test pressure loading;
- radial loads;
- drill pipe hang off loads.

It is not necessary that the bore protectors or wear bushings meet the requirements of Clause 5.

### 8.9.2.2 Vertical bores

#### 8.9.2.2.1 Full opening vertical bores

The minimum vertical bore of the bore protector shall be as given in Table 33. The minimum vertical bore through wear bushings shall be as given in Table 32. Bore protectors and wear bushings conforming to these requirements shall be referred to as having full-opening bores.

#### 8.9.2.2.2 Reduced opening vertical bores

Reduced vertical bores may also be supplied.

#### 8.9.2.2.3 Wear bushings and bore protectors

Wear bushings and bore protectors shall have lead-in tapers top and bottom to avoid causing the bit or tool passing through them to hang up.

**Table 33 — Minimum vertical bores for bore protectors**

BOP stack sizes mm (in)	Minimum vertical bore mm (in)
346 (13 5/8)	312 (12,31)
425 (16 3/4)	384 (15,12)
476 (18 3/4)	446 (17,56)
527 to 540 (20 3/4 to 21 1/4)	472 (18,59)

### 8.9.2.3 Outside profile

The outside profile shall be in accordance with the manufacturer's written specifications.

### 8.9.2.4 Rated working pressure

Bore protectors and wear bushings are not normally designed to retain pressure.

#### 8.9.2.5 Lockdown/anti-rotation

The wear bushings and bore protectors shall be designed such that they are locked in place and are restrained from rotation as required. Manufacturer shall document lockdown, retrieval and anti-rotation design loads.

#### 8.9.3 Materials

The materials used in bore protectors and wear bushings shall comply with the manufacturer's written specifications. Recommendations for hardness of wear bushings can be found in ISO 10423.

#### 8.9.4 Testing

Bore protectors and wear bushing shall be dimensionally inspected to confirm minimum vertical bore.

#### 8.10 Corrosion cap

The function of the corrosion cap is to protect the subsea wellhead from contamination by debris, marine growth and corrosion. These caps usually are non-pressure-containing and lock onto the external profile of the wellhead housing. If a pressure retaining cap is utilized, means shall be provided for sensing and relieving pressure prior to releasing the cap. The cap is installed just prior to temporary abandonment of a well. It may be a design that allows installation prior to, or after installation of, the tubing hanger. The cap may be required to have the facility for injection of a corrosion inhibitor into the well.

The corrosion cap may be run with a dedicated tool or by ROV. Consideration shall be given to the length of time the cap is expected to be on the wellhead with respect to corrosion of the cap itself and the provision of cathodic protection. Due consideration shall also be given to the method of inhibiting the well, especially where personnel can be exposed to inhibitor chemicals.

#### 8.11 Running, retrieving and testing tools

Tools for running, retrieving and for testing all subsea wellhead components, including guidance equipment, housings, casing suspension equipment, annulus sealing equipment and protective devices, are addressed in Annex H.

#### 8.12 Trawl protective structure

An over-trawlable protection structure shall be provided when requested by the user. The structure may serve a dual purpose:

- external protection to foreign objects against being dropped/dragged or snagged;
- internal corrosion protection of seal surfaces.

#### 8.13 Wellhead inclination and orientation

For ease of current and future operations, the conductor should be as close to vertical as possible. An inclination of 0,5° or less helps to ensure that future completion scenarios are possible. An inclination of between 0,5° and 1,0° can restrict options for tiebacks, well completion and re-entry, but can be safely drilled by making some adjustments to rig position. Readings of more than 1° can lead to damage due to drill-pipe key seating between the casing hanger and flex joint, even with rig position adjustments; and an angle greater than 1,25° can severely restrict future operations. Additional guidance can be obtained by consulting the manufacturer following a discussion with the user on intended future well activities. In any event, the actual inclination and azimuth of the wellhead (for example 0,4°, with top of wellhead leaning toward 258° from true north) shall be recorded in the job report and well file.

Typical considerations when determining the acceptable inclination are as follows.

- performance capabilities of equipment and tooling;
- subsequent operations that will be performed: Do they involve a subsea tree, template, tieback to surface for a platform, or floating production facility;
- size and configuration of subsea test tree, if a horizontal tree will be used;
- length of tubing hanger, tieback, etc.;
- water depth, currents and sea states, in general, which can increase the sensitivity to being off vertical;
- well re-entry methods and frequency of re-entry;
- record keeping, likelihood that someone will check the slope indicator records in future before re-entering the well;
- relative angle between marine riser and bop/wellhead;
- whether angle of wellhead can change over time;
- uncertainty of angle measurements, now and in the future;
- allowable angles, which can be different for installation and retrieval; generally retrieval is more difficult because tension increases drag when not aligned;
- likely increase in wear/key seating on bore surfaces and tools as inclination increases;
- ability to migrate rig position to align the riser with the wellhead.

## 8.14 Submudline casing hanger and seal assemblies

### 8.14.1 General

Submudline casing hangers provide a suspension point for additional intermediate casing strings that cannot be accommodated by a standard conductor or wellhead housings. Submudline casing hanger seal assemblies provide pressure isolation between the submudline landing ring and submudline casing hanger. Submudline landing rings are integrally incorporated into the casing string below a subsea wellhead or low-pressure housing. Submudline casing hangers suspend the next casing string, landing on and transferring their loads to the landing ring. Load limits and pressure ratings for the landing ring, the submudline casing hanger and seal assembly shall be defined by the manufacturer. The user should define the material, interface and design-load requirements of the casing strings that incorporate the submudline landing ring and casing hanger in the well design. Submudline seal assemblies are actuated by various methods, including torque, weight and/or hydraulic pressure.

### 8.14.2 Design

Submudline landing rings and casing hangers are integral parts of casing strings. They are, therefore, specifically excluded from the design requirements and pressure rating methods assigned to like components in Clause 8. Design requirements and allowable stresses for these components are provided in 10.1.2 dealing with mudline suspension equipment. These allowable stresses are in keeping with current industry practice for safe working pressures for casing. Equipment ratings should remain the same regardless of their location in the casing string. Submudline landing rings and casing hangers should not be subjected to the rated working pressure nor test pressure associated with the low-pressure or high-pressure wellhead housing when a landing ring is placed directly below these housings.

Submudline seals, seal assemblies and submudline emergency seal assemblies shall be treated as pressure-controlling equipment as defined in 8.7. They are also specifically excluded from the pressure-rating methods assigned to like components in Clause 8, and specifically given a pressure rating commensurate with that of the corresponding submudline landing ring and casing hanger.

## 9 Specific requirements — Subsea tubing hanger system

### 9.1 General

The tubing-hanger system is comprised of a tubing-suspension device called a tubing hanger and an associated tubing-hanger running tool and, in certain cases, an orientation joint. This part of ISO 13628 is limited to tubing hangers that are landed in a wellhead, tubing head or horizontal tree. A tubing annulus seal is effected between the tubing hanger of the casing hanger, the tubing head or the horizontal tree, and the hanger is locked in place. It is designed to provide a means for making a pressure-tight connection between the tubing string(s), tubing annulus and the corresponding subsea tree or tubing-hanger running tool bores. It may also provide a continuous means of communication or control of SCSSVs, electrical transducers and/or other downhole devices.

There are three basic types of tubing hangers:

- a) concentric;
- b) eccentric (those that require orientation to align multiple tubing bores or control ports);
- c) horizontal tree type.

See Annex D for representative illustrations of these tubing hanger types.

There are two types of orientation systems:

- active (rotary) type, requiring the rotation of the running string by the application of torque at the surface, until it locates an orientation device that orients the hanger relative to the wellhead/tubing head/horizontal tree;
- passive (linear) type, uses downward or upward motion of the running string to engage a pin or key in an orientation device that automatically orients the hanger relative to the wellhead/tubing head/horizontal tree.

### 9.2 Design

#### 9.2.1 General

The OD of the tubing hanger system shall be compatible with the ID of the BOP stack and marine riser system being used. Particular attention shall be given to the design of the lock and seal mechanisms to minimize the risk of their hanging up during installation or retrieval. The design should keep diameters to the minimum and minimize the length of large diameters in order to ease running and retrieving of the tubing-hanger system through the ball/flex joint. The operating procedures should advise the limiting ball/flex-joint angle for running and retrieving of the tubing hanger system. The design of tubing hanger systems shall comply with 5.1. Irrespective of orientation system, the seals shall not engage in the sealing bore until the orientation is complete. Typical orientation devices are keys that engage slots in the BOP connector, orienting bushings/cams temporarily installed in the BOP connector, orienting bushings/cams permanently installed in the tubing head or horizontal tree body and extending pins in the BOP stack used in conjunction with a camming profile on the running tool or orientation joint.

The orientation joint is outside the scope of this part of ISO 13628.



On concentric tubing-hanger systems and horizontal trees, annulus access may be through an outlet below the tubing hanger in the tubing head or horizontal tree body. Where it is through the hanger and into the tree connector cavity area, provision shall be provided for sealing off the annulus bore by the use of a check valve, sliding sleeve or similar device.

The tubing hanger running tool may be mechanically or hydraulically actuated. On hydraulically actuated designs, the running tool shall be of a “fail-as-is” design, so that in the event of loss of control pressure, it shall not result in the release of the tubing hanger from its running tool. There shall be positive indication that the running tool is correctly attached to the tubing hanger before supporting the weight of the tubing string. It is a requirement to effect release of the hydraulic running tool from the tubing hanger in the event of lost hydraulic control pressure. The top of the running tool/orientation joint shall interface with the completion riser, tubing strings or drill pipe as specified by the manufacturer. On horizontal tree applications, the top of the running tool/extension joint shall interface with the tieback string or subsea test tree.

### 9.2.2 Loads

As a minimum, the following loads shall be considered and documented by the manufacturer when designing the tubing hanger system:

- suspended weight;
- overpull;
- pressure, internal and external;
- tubing hanger/running tool separation loads due to pressure testing;
- thermal loads;
- torsional loads;
- radial loads;
- oriented loads;
- tree-reacting loads.

### 9.2.3 Threaded connections

#### 9.2.3.1 Tubing hanger

The type of tubing threads on the hanger shall be specified by the user. Identification markings shall conform to ISO 10423. Tubing threads should be coated to prevent galling when required by the thread type or material.

#### 9.2.3.2 Running tool

Tubing threads or tool joints, if used, shall be in accordance with API RP 5B or ISO 10424-1 or the manufacturer’s written specification. The tool shall have adequate dimension for tonging.

The load capacity of the tool shall not be inferred from the choice of end connections on the tools.

### 9.2.4 Running tool seals

All stab subs and other sealing elements shall have a minimum of one elastomer seal. If additional seals are used, hydraulic lock issues should be considered.

### 9.2.5 Vertical bores

The minimum vertical bore with and without profiles shall comply with the manufacturer's written specification. The effect of wall-thickness reduction due to plug profiles in the tubing hanger shall be included in the design analysis and documented as required in 5.1. The plug-latching profile may be machined in an insert or may be machined directly into the tubing hanger. The tubing hanger bores shall be drifted in accordance with manufacturer's written specifications. When specified by the manufacturer, the annulus bore shall include a plug-catcher device, which may be integral or threaded to the hanger. When specified by the user, the plug profiles shall be in nipples threaded into the bottom of the hanger.

On horizontal trees, straddle sleeves are provided for the protection of the plug profiles during downhole wireline or coiled tubing interventions. In addition, an isolation straddle sleeve shall be required to close off the tubing-hanger side outlet during tripping in and out of the hole.

### 9.2.6 Tubing hanger plugs

Tubing-hanger plugs used in vertical trees are used as a temporary closure device and, as such, are not covered under the provisions of 9.2.6. Tubing-hanger plugs used with horizontal trees are called crown plugs and are utilized as permanent pressure barriers. Crown plugs shall meet the general design criteria, material and testing requirements of an internal tree cap as stated in 7.12 and Tables 4 and 5.

### 9.2.7 Rated working pressure

The tubing hanger shall have a rated working pressure of either 34,5 MPa (5 000 psi), 69 MPa (10 000 psi), or 103,5 MPa (15 000 psi). This rating shall be exclusive of the tubing connection(s) at the bottom of the hanger. Any operating control or injection passage through the tubing hanger body shall have a minimum pressure rating equal to 1,0 times RWP, up to a pressure rating equal to 1,0 times RWP plus 17,2 MPa (2 500 psi).

The rated working pressure of the tubing hanger shall be equal to the tree pressure rating of either 34,5 MPa (5 000 psi), 69 MPa (10 000 psi), or 103,5 MPa (15 000 psi). The tubing-hanger lockdown mechanism and annulus-seal assembly shall have a design capability to retain a pressure load of 1,1 times RWP for a vertical tree completion system. The tubing-hanger lockdown mechanism and annulus-seal assembly shall have a design capability to retain a pressure load of 1,5 times the RWP for a horizontal tree completion system.

### 9.2.8 Seal barriers

There shall be a minimum of two seal barriers between the production and annulus bores of the tubing hanger and the environment. ISO 13628-1 discusses seal barrier philosophy and provides examples.

### 9.2.9 SCSSV and chemical-injection control-line stab design

There shall be a minimum of two seal barriers between the SCSSV and chemical-injection control-line stabs of the tubing hanger and the environment.

On vertical tree applications, SCSSV control-line stabs in the tubing hanger shall be designed so as to vent control pressure when the tree is removed. The SCSSV control stab shall be designed to minimize the ingress of debris and seawater when the tree is removed. The pressure rating of the control line stabs shall be the same as or greater than the SCSSV control pressure and shall be selected from 9.2.7.

On horizontal tree applications, the horizontal SCSSV control line stab may contain an integral coupler with poppet check valve or other valve type for the purpose of isolating the wellbore completion fluid from the control-line internal control fluid. However, the check valve shall not interfere with the intended function of the SCSSV.

### 9.2.10 Miscellaneous tools

Miscellaneous tools, such as storage and test stands, emergency recovery tools, inspection stands, lead impression tools, wireline-installed internal isolation sleeves (horizontal tree), shall be supplied as needed.

### 9.3 Materials

Materials shall conform to 5.2. Seal surfaces that engage metal-to-metal seals shall be inlaid with or be made from a corrosion-resistant material that is compatible with well fluids, seawater, etc.

For forged material used for pressure-containing and high-load-bearing parts, forging practices, heat treatment and test coupon (QTC or prolongation) requirements should meet those of API RP 6HT. In addition, the test coupon shall accompany the material it qualifies through all thermal processing, excluding stress relief.

### 9.4 Testing

#### 9.4.1 Validation testing

Validation testing of the tubing hanger shall comply with 5.1.7. In addition, the tubing-hanger lockdown shall be tested to a minimum of 1,1 times RWP for VXT or 1,5 times RWP for HXT from below and from above to 1,0 times RWP for both. Where annulus-access devices (e.g. poppet, shuttle, sliding sleeve, etc.) and chemical-injection stab barriers are incorporated into the tubing hanger design, these shall meet the design performance qualification requirements as shown in Table 3.

#### 9.4.2 Factory acceptance testing

##### 9.4.2.1 Tubing hanger

All tubing hangers shall be hydrostatically tested prior to shipment from the manufacturer's facility. The hydrostatic body test pressure of production and annulus bores shall be equal to or greater than 1,5 times RWP in accordance with the requirements in 5.4.5. All operating control or injection passages through the tubing-hanger body shall be hydrostatically tested to 1,5 times their respective RWPs in accordance with 5.4.5.

A pup joint of tubing shall be installed on the hanger and the connection hydrostatic tested to manufacturer's written specifications.

Tubing hanger internal profiles shall be drifted and pressure tested with a mating plug or fixture to the manufacturer's written specifications. The pressure test for this profile and plug in a horizontal completion system shall be 1,5 times the RWP of the tubing hanger.

Functional testing shall be conducted in accordance with the manufacturer's written specification to verify the primary and secondary operating and release mechanisms, override mechanisms, locking mechanisms, instrumentation and control line. Testing shall verify that the actual operating forces/pressures fall within the manufacturer's documented specifications.

##### 9.4.2.2 Tubing hanger running tool

All wellbore pressure-containing/controlling components shall comply with the hydrostatic test requirements of 5.4.5 with the addition that the through-bores of the running tools shall be tested to a test pressure equal to at least 1,5 times RWP.

Components having multiple bores or ports shall have each bore or port tested individually if there is possibility of intercommunication.

Components that contain hydraulic control fluid shall be subjected to a hydrostatic body/shell test in accordance with the requirements given in 5.4.7.

Functional testing shall be conducted in accordance with the manufacturer's written specification to verify the primary and secondary operating and release mechanisms, override mechanisms, locking mechanisms, instrumentation and control line. Testing shall verify that the actual operating forces/pressures fall within the manufacturer's documented specifications.

## 10 Specific requirements — Mudline suspension equipment

### 10.1 General

#### 10.1.1 Introduction

**10.1.1.1** Clause 10 covers drilling and completion equipment used to suspend the casing weight at or near the mudline, to provide pressure control and to provide annulus access to the surface wellhead. Mudline equipment is used when drilling with a bottom-supported rig or platform and provides for drilling, abandonment and tiebacks to either a platform or subsea completion. Mudline landing rings and hangers can sometimes be used as part of the casing string below a subsea wellhead. Such parts shall comply with the requirements of 8.14.

Mudline casing hangers, casing hanger running tools (landing subs), casing hanger landing rings, and tieback tools (tieback subs) are, in fact, an integral part of the casing strings. They are therefore specifically excluded from the design requirements and pressure rating methods assigned to like components in ISO 10423 and Clause 8, and specifically given the design requirements and allowable stresses in 10.1 through 10.5. These allowable stresses are in keeping with current industry practice for safe working pressures for casing.

Mudline equipment typically involves proprietary profiles/configurations and/or ISO standard connections. The tools used for installation, retrieval and testing are typically task-specific and remotely operated.

**10.1.1.2** The technical content of Clause 10 provides equipment-specific requirements for performance, design, material and testing. Specific mudline suspension equipment used during drilling and/or run as part of the casing string includes the following; see Figure E.1:

- landing rings;
- casing hangers;
- casing hanger running tools (landing subs);
- tieback adapters (tieback subs);
- abandonment caps.

**10.1.1.3** Major components of mudline suspension equipment used during drilling and/or run as part of the casing string are designated as pressure-controlling parts as defined in ISO 10423. For quality control purposes, these components shall be treated as “casing and tubing hanger mandrels” as set forth in ISO 10423.

Specific mudline conversion equipment for subsea completions includes the following; see Figure E.2:

- mudline conversion equipment (with space-out adjustment);
- tubing head assemblies.

**10.1.1.5** Major components of mudline-conversion equipment shall be designated as either pressure-containing or pressure-controlling parts using the definitions set forth in ISO 10423. Components designated as pressure-containing parts shall be treated as “bodies” in ISO 10423.

High-pressure risers and accessory tools used with mudline equipment, such as brush and cleanout tools, cap running tools, etc., are beyond the scope of this part of ISO 13628.

## 10.1.2 Design

### 10.1.2.1 General

The general design requirements for mudline equipment shall comply with 5.1. If specific requirements for mudline equipment in Cause 10 differ from the general requirements stated in 5.1, these specific requirements shall take precedence.

### 10.1.2.2 Rated working pressure

For each piece of mudline equipment, a rated working pressure shall be determined in accordance with Table 34 and Annex E, or by proof testing as specified in ISO 10423.

The rated working pressure shall be inclusive of the pressure capacity of the end connections.

**Table 34 — Maximum allowable stress due to pressure<sup>a,b</sup>**  
(for mudline equipment only)

Allowable stress	At rated working pressure		At test pressure
	Suspension equipment	Conversion equipment	Suspension & conversion equipment
Membrane	<i>Membrane stress = <math>S_m</math> (where <math>S_m + S_b \leq 1 \times S_{yld}</math>)</i>		
	$0,8 \times S_{yld}$	$0,67 \times S_{yld}$	$0,9 \times S_{yld}$
Membrane + bending	<i>Membrane + bending = <math>S_m + S_b</math> (where <math>S_m \leq 0,67 \times S_{yld}</math>)</i>		
	$1,2 \times S_{yld}$	$1,0 \times S_{yld}$	$1,35 \times S_{yld}$
	<i>Membrane + bending = <math>S_m + S_b</math> (where <math>0,67 \times S_{yld} \leq S_m \leq 0,9 \times S_{yld}</math>)</i>		
	$2,004 \times S_{yld} - 1,2 \times S_m$	N/A	$2,15 \times S_{yld} - 1,2 \times S_m$
Key: $S_m$ is the calculated membrane stress. $S_b$ is the calculated bending stress. $S_{yld}$ is the minimum specified yield stress. <sup>a</sup> Stresses given in this table shall be determined in accordance with the definitions and methods presented in Annex E. The designer shall consider the effects of stresses beyond the yield point on non-integral connections, such as threaded connections and latch profiles, where progressive distortion can result. <sup>b</sup> Bending stresses in this method are limited to values lower than are permitted by the ASME method for secondary stresses, since this table provides a limit-based method with inherently higher safety margins. An alternative method is included in Annex E to permit higher secondary stresses while controlling membrane stresses to the traditional, more conservative limits.			

### 10.1.2.3 Hanging/running capacity rating

#### 10.1.2.3.1 Rating running capacity

A rated running capacity shall be determined for each piece of mudline suspension equipment in the load path between the top connection of the running tool and the lower connection of the hanger that is run as part of the casing string. The rated running capacity is defined as the maximum weight that can be run below the mudline component. Rated running capacity is not the same as joint strength, ultimate tensile strength or proof test load.

Rated running capacity includes the tension capacity of the threaded end connection that is machined into the mudline component and excludes thread pullout strength for the threaded end connection since pullout strength is a function of the weight and grade of casing that is threaded into the mudline component during use.

Primary membrane stresses in the body at the rated running capacity shall not exceed 80 % of the minimum specified yield strength and shall be exclusive of internally applied pressure and externally applied global bending loads.

#### 10.1.2.3.2 Rated hanging capacity

The rated hanging capacities shall be determined for each piece of mudline suspension equipment that hangs casing weight. The rated hanging capacity is defined as the maximum weight that can be suspended from the component at the rated location.

Different rated hanging capacities can be required for several locations on the component. For example, each external expanding latch or fixed landing ring and each internal latch profile or internal landing shoulder(s) shall have a rated hanging capacity.

Compressive stresses at load shoulders shall be permitted to exceed material yield strength at the rated hanging capacity provided that all other performance requirements are satisfied.

Rated hanging capacities shall include the effects of full rated working pressure. Both internal and external pressure shall be included. Primary membrane stresses in the body at the rated hanging capacities shall not exceed 80 % of minimum specified yield strength.

Rated hanging capacities shall be documented by the manufacturer for a given set of nested equipment in an assembly or for each component individually.

#### 10.1.2.4 Outside and inside diameters

The manufacturer shall document minimum ID and maximum OD dimensions for mudline equipment. These values shall be based on machining dimensions, and shall be stated in decimal form to the nearest 0,02 mm (0,001 in.). This requirement applies only to IDs which must pass (admit) other mudline components and to ODs that must pass through other mudline components. Outside dimensions shall exclude the expanded condition of expanding latches.

#### 10.1.2.5 Flow-by areas

Manufacturers shall document the minimum flow-by area and maximum particle size provided for each design, including:

- flow-by area while running through a specified weight of casing;
- flow-by area when landed in a specified mudline component;
- critical velocity for running-tool wash ports.

#### 10.1.2.6 Temperature ratings

Each component shall have a temperature rating as specified in 5.1.2.2.

#### 10.1.2.7 Misalignment

The manufacturer shall document allowable inclination from vertical for drilling and production tieback.

### 10.1.3 Materials

#### 10.1.3.1 Material classes

Appropriate material classes for mudline equipment are AA through CC for general service, and DD through HH for sour service as defined by ISO 10423.

NOTE For the purposes of this provision, NACE MR0175 is equivalent to ISO 15156 (all parts).

Subsea mudline completion equipment shall follow appropriate material classes AA to HH listed in Table 1.

#### 10.1.3.2 NACE requirements

For material classes DD through HH (sour service), ISO 15156 (all parts) requirements shall be limited to the internal pressure-containing and pressure-controlling components exposed to wellbore fluids. For example, sour-service mudline hangers may include non-NACE external latch mechanisms and load rings.

NOTE For the purposes of this provision, NACE MR0175 is equivalent to ISO 15156 (all parts).

### 10.1.4 Testing

#### 10.1.4.1 Validation testing

Manufacturers are required to conduct and document validation testing results in accordance with 5.1.7.

#### 10.1.4.2 Factory acceptance testing

##### 10.1.4.2.1 Hydrostatic testing

Hydrostatic factory acceptance testing of mudline suspension equipment is not a requirement. If included in the manufacturer's written specification, then test pressures shall not exceed the test pressure as determined in E.2.5.

Hydrostatic factory acceptance testing of mudline conversion equipment is mandatory and shall be tested in accordance with 5.4.5.

##### 10.1.4.2.2 Drift testing

Drift testing is not a requirement of this part of ISO 13628. If drift testing is included in the manufacturer's written specification, then the requirements in ISO 11960, Clause 7, shall be followed. The drift test may specify either individual component drift testing or assembly drift testing (i.e. hanger, running tool and casing pups assembled together).

##### 10.1.4.2.3 Stack-up and fit test

A stack-up and fit test is not required by this part of ISO 13628. If stack-up and fit testing is part of the manufacturer's written specification, then the manufacturer shall document the requirements for measuring and/or recording axial and drift dimensions that shall be taken to verify proper stack-up.

### 10.1.5 Marking and documentation

10.1.5.1 All mudline equipment shall be stamped with at least the following information:

- manufacturer's name or trademark;
- size;

- assembly serial number, if applicable;
- part number and revision;
- material class and maximum H<sub>2</sub>S partial pressure.

**10.1.5.2** The following information shall be either stamped on the equipment or provided in the system documentation as applicable:

- rated working pressure;
- rated running capacity;
- rated hanging capacity;
- minimum flowby area;
- maximum particle size;
- drift diameter;
- maximum allowable test pressure;
- maximum make up and breakout torque;
- maximum wash port flow rate.

**10.1.5.3** In addition to the requirements in 10.1.5.1 and 10.1.5.2, mudline conversion equipment shall be stamped in accordance with 5.5.

## 10.2 Mudline suspension-landing/elevation ring

### 10.2.1 Description

The landing/elevation ring is an internal upset located at or near the mudline to provide an internal landing shoulder for supporting all combined casing loads. The following considerations shall be addressed when generating designs and technical specifications for the landing elevation ring:

- shoulder load-bearing strength;
- completion elevation above mudline;
- centralization of casing hangers;
- mud and cement return flowby area.

### 10.2.2 Design

The following criteria shall be considered and documented by the manufacturer when designing the landing/elevation ring:

- structural loads, including casing-hanging loads;
- dimensional compatibility with other hangers;
- dimensional compatibility with specified bit programme;



- welding requirements;
- mud flowby requirements.

The minimum ID of each ring shall be selected to allow both the landing of subsequent casing hangers and the passage of bit sizes to be used.

### 10.2.3 Documentation

The manufacturer shall document any critical alignment and/or welding requirements for attachment of the landing/elevation ring to the conductor pipe.

## 10.3 Casing hangers

### 10.3.1 Description

#### 10.3.1.1 Mudline casing hangers

Mudline casing hangers typically provide the following functions and features within the mudline suspension system:

- support casing weight at mudline;
- support casing weight of subsequent strings;
- allow annulus access to the surface wellhead;
- allow for mud/cement flowby while running and landing in previous hanger;
- allow attachment of running tool, tieback riser sub and/or subsea conversion equipment;
- provide for reciprocating the casing string during cementing operations.

#### 10.3.1.2 End connections

The casing hanger and running tool are normally installed with casing extensions made up to both ends. Normally, the running tool (landing sub) extension has a pin-by-box casing nipple extension, and the casing hanger has a pin-by-pin casing extension. The assembly of casing extensions, running tool and casing hanger shall be done prior to shipment to the rig. This allows the handling and running of the casing-hanger assembly as just another piece of casing.

#### 10.3.1.3 Landing shoulders

Landing shoulders on casing hangers are typically one of two following types:

- fixed support rings;
- non-fixed or expanding/contracting latch rings.

The fixed support ring lands on a bevelled landing shoulder (usually 45°) in the landing ring or previous casing hanger. Flowby porting for mud and cement passage and adequate bearing capacity is maintained on this landing ring.

The non-fixed support ring has an expanding/contracting latching load ring that locates in the appropriate landing groove. In some cases during cementing operations, the casing is reciprocated a short distance above the hanger seat. Therefore, the non-fixed landing rings typically do not have permanent lockdown mechanisms.

#### 10.3.1.4 Internal profiles

The internal profiles of mudline casing hangers serve these functions:

- lock and seal running tool (landing sub) and tieback adapters;
- seat subsequent casing hangers;
- seat tubing hanger (optional).

The lock and seal mechanism for the running tool and tieback adapters is usually the upper internal profile of the mudline casing hanger. The locking profile may be a thread or an internal locking groove for a cam-actuated locking mechanism. The running tool is usually designed to release with right-hand rotation.

Wash ports may be incorporated as necessary into each landing sub or casing hanger to give a washout flow rate, without cutting out the port area. After the casing hanger has been landed and cemented, the wash ports are opened. After flushing out the casing riser annulus, the wash ports are closed. The purpose of washing out the casing riser area is to ensure that excessive cement has been removed from the casing hanger/running tool connection area.

#### 10.3.2 Design

##### 10.3.2.1 Loads

The following loads shall be considered and documented by the manufacturer when designing mudline system casing hangers:

- casing loads;
- pressure;
- operating torque.

##### 10.3.2.2 Flowby area

Casing-hanger minimum flowby areas shall be documented by the manufacturer for each casing-hanger design configuration.

##### 10.3.2.3 Particle size

The maximum particle size shall be documented for each casing hanger-design configuration.

##### 10.3.2.4 End connections

Standard ISO or other end connections provided on the casing hanger and running tool (landing sub) shall comply with the requirements of 7.1 through 7.6.

Adequate surface areas for tongs should be provided for installing the casing into the casing hanger and running tool (landing sub).

#### 10.4 Casing hanger running tools and tieback adapters

##### 10.4.1 Description

Casing-hanger running tools shall be designed to provide a reversible connection between the mudline hanger and the casing riser used for drilling operations. They may be either threaded (including an optional weight set) or cam-actuated tools as supplied by each individual manufacturer. Threaded running tools engage

directly into the casing hanger. Cam-actuated tools engage in an internal locking groove inside of the casing hanger. Wash ports may be provided in the casing hanger or landing sub to allow for cleaning of cement from around the previously run hanger/landing sub connection.

Casing-hanger tieback adapters (tieback subs) are used to connect casing pipe joints to mudline suspension wellhead equipment for either surface wellhead completions or subsea completion purposes. The requirements for tieback adapters shall be the same as those for casing hanger running tools.

Mudline casing hangers and tieback adapters shall be treated as pressure-controlling equipment as defined in ISO 10423.

## 10.4.2 Design

### 10.4.2.1 Loads

As a minimum, the following loads shall be considered and documented by the manufacturer when designing the running tools:

- suspended weight;
- pressure loads;
- torque;
- overpull;
- environmental loads.

### 10.4.2.2 Threaded running and tieback adapters

Threaded running tools shall be right-hand release. Threaded tieback adapters and tieback profiles shall be right-hand make-up.

The manufacturer shall document maximum flow rate through washout ports.

## 10.5 Abandonment caps

### 10.5.1 Description

Abandonment caps, typically, are used during temporary abandonment and protect internal hanger profiles, threads and seal areas from marine growth, mechanical damage and debris.

### 10.5.2 Design

Pressure and any external loads applied during installation, pressure relief and retrieval shall be considered and documented by the manufacturer in the design of abandonment caps. Abandonment caps shall be equipped with a means of relieving pressure prior to removal.

## 10.6 Mudline conversion equipment for subsea completions

### 10.6.1 Description

Mudline conversions for subsea completion provide the interface between mudline suspension equipment and subsea completion equipment; see Figure E.2. Care shall be exercised when specifying *in situ* testing of conversion equipment such that the suspension equipment does not see higher pressure than it is rated for.

Major components of mudline conversion equipment shall be treated as pressure-controlling parts as defined in ISO 10423.

### 10.6.2 Design

Mudline conversions typically provide limited structural support, centralization and pressure control for preparing a well drilled with mudline hangers for a subsea completion.

The lower end of mudline conversion equipment shall provide a load shoulder (or threaded) and sealing interface for at least two tieback adapters and casing strings. The conversion may also provide a centralizing and load-bearing feature to provide structural integrity to transfer applied loads to the surface casing or conductor pipe. The mudline conversion hardware also shall feature the necessary adjustment capability to accommodate the spacing between the mudline wellhead casing hangers, the surface pipe end and the subsea completion hardware.

The upper end of mudline conversion equipment shall feature a tubing-head assembly to interface with a high-pressure completion riser, the subsea tubing hanger and subsea tree. The tubing head also interfaces with the tubing hanger/wear bushing, riser testing plug equipment and an annulus access connection to one or more of the annular spaces between the casing strings/tieback adapters below.

Care shall be exercised when specifying *in situ* testing of mudline conversion equipment such that the suspension equipment does not see higher pressures than pressure rating for the well's casing, the tieback adapter, or the casing strings installed above and below the casing hanger.

The casing riser string that attaches to the tubing head is often the defining requirement for pressure rating and equipment size for a mudline conversion system. Usually, this riser string has a thicker wall and/or is made from the higher-strength materials required to withstand both internal pressure and external environmental loads. The riser also has to feature a tensioning point, similar to floating drilling risers, to assist in resisting environmental conditions. Therefore, careful weighing of drift diameter, NACE or non-NACE service, connector size and strength and material availability shall be examined versus the well's requirements and environment to determine suitability.

Bodies of mudline conversion tubing-head assemblies shall be treated as pressure-containing parts as defined in ISO 10423.

### 10.6.3 Rated working pressure

The RWP for the tubing-head assembly pressure boundary shall be based on the RWP of the casing riser used to complete the well and install tubing strings. Selection of the rated working pressure should consider the maximum expected SCSSV operating pressure; see 5.1.2.1.1.

### 10.6.4 Factory acceptance testing

All tubing-head assemblies shall be hydrostatically tested prior to shipment from the manufacturer's facility. They shall be tested to the requirements of this part of ISO 13628 with the addition that the tests (including PSL 2) shall have a secondary holding period of not less than 15 min. The hydrostatic test is performed to verify the pressure integrity of the housing pressure boundary.

The overall hydrostatic body test pressure shall be determined by the lesser of either the rated working pressure of the tubing head's body or the high-pressure casing-string riser's pressure rating; as defined in Annex E. Typical pressure ratings for the tubing head assembly are listed in Table 35.

## 10.7 Tubing hanger system — Mudline conversion equipment for subsea completions

All design, materials and testing of the tubing hanger system shall be in accordance with Clause 9.

## 11 Specific requirements — Drill-through mudline suspension equipment

### 11.1 General

Clause 11 describes drill-through mudline suspension equipment that is normally run from a bottom-supported drilling rig. Drill-through mudline suspension equipment is used when it is anticipated that the well will be drilled and completed without suspending the well and nipping down the surface BOP, and culminating in a subsea completion interface for installing a subsea tree. Drill-through equipment is a hybrid between mudline wellhead and subsea wellhead technology. The equipment is configured in such a way, starting with individual mudline casing hangers and risers and then switching over to a special casing hanger that has a housing that can accommodate the casing hanger(s), annulus seal assembly(s) and tubing hanger when installed, such that no conversion equipment is required for subsea completion. The casing-hanger housing is typically a 346 mm (13 5/8 in) size. The riser back to the surface typically has a pressure rating that meets or exceeds the pressure rating for all of the casing hangers, seal assemblies and tubing hanger installed afterwards into the hybrid casing hanger housing. Figure F.1 illustrates a typical drill-through mudline suspension arrangement.

All pressure-containing and pressure-controlling parts included as part of the drill-through mudline suspension equipment shall be designed to meet all of the requirements of the specified material class and ISO 15156 (all parts) for the casing-hanger housing, and all of the components installed inside it. Mudline suspension hardware external to the hybrid housing may be non-NACE depending on the surface-casing design. The innermost casing riser string that attaches to the hybrid casing-hanger housing is often the defining requirement for pressure rating and equipment size for a drill-through system. Usually, this riser string has a thicker wall and/or is made from the higher-strength materials required to achieve a higher-than-average pressure rating. Therefore, careful consideration of drift diameter, NACE or non-NACE service, connector size and strength and material availability shall be done versus the well's requirements to determine the suitability of such a system.

NOTE For the purposes of this provision, NACE MR0175 is equivalent to ISO 15156 (all parts).

### 11.2 External drill-through casing hangers (outside of the hybrid casing hanger housing)

All drill-through mudline casing hangers external to the hybrid casing hanger housing shall be designed and manufactured in accordance with 10.1 through 10.4.

External drill-through mudline casing hanger bodies shall be treated as pressure-controlling parts as defined in ISO 10423.

### 11.3 Hybrid casing hanger housing

#### 11.3.1 General

The hybrid casing-hanger housing lands inside the last mudline suspension casing-hanger landing ring. It provides pressure integrity for the well, suspends the intermediate and subsequent casing strings, the tubing hanger when installed and transfers external loads back into the surface casing hanger. Internally, it has a landing shoulder for the subsequent hangers and an internal profile for a running/tie-back tool. The subsea tree attaches and seals to the upper connection after the drilling phase is complete.

Hybrid casing hanger housings shall be treated as pressure-containing equipment as defined in ISO 10423.

### 11.3.2 Design

#### 11.3.2.1 Loads

As a minimum, the following loads shall be considered and documented by the manufacturer when designing the high-pressure housing:

- riser forces (drilling, production and workover, including tension);
- fatigue loads;
- subsea tree loads;
- pressure;
- radial loads;
- thermal loads;
- environmental loads;
- flowline loads;
- suspended casing loads;
- surface casing hanger/conductor housing reactions;
- tubing-hanger reactions;
- riser and tree connector loads.

#### 11.3.2.2 Connections

##### 11.3.2.2.1 Top connection

The top connection should be of a hub or mandrel type (see Figure 14) as specified by the manufacturer. The gasket profiles shall be manufactured from or inlaid with corrosion-resistant material as specified in 5.3.3.

##### 11.3.2.2.2 Bottom connection

The high-pressure housing attaches to the top of the intermediate casing to form the basic foundation of a subsea well. If the bottom connection is being welded, it shall be prepared for a full penetration butt-weld. If threaded, the type of casing thread on the housing shall be as specified in ISO 10423.

##### 11.3.2.2.3 Pup joint

The wellhead housing may have a pup joint that is factory-welded on to ease field installation or threaded into the housing.

### 11.3.3 Dimensions

The dimensional requirements are as follows.

- a) The minimum bore of the housing shall not be less than the drift diameter of the intermediate casing. The manufacturer shall document the through-bore size.
- b) Dimensions of the wellhead pressure boundary (see Figure 14) shall be in accordance with the manufacturer's written specification.
- c) The wellhead-housing minimum flow-by area shall be documented by the manufacturer.

### 11.3.4 Rated working pressure

The RWP for the hybrid casing hanger housing pressure boundary (see 3.1.63) shall be based on the RWP of the casing riser used to drill and complete the remaining casing and tubing strings for the well. Selection of the rated working pressure should consider the maximum expected SCSSV operating pressure; see 5.1.2.1.1.

### 11.3.5 Factory acceptance testing

All hybrid casing-hanger housings shall be hydrostatically tested prior to shipment from the manufacturer's facility. They shall be tested to the requirements of this part of ISO 13628, with the addition that the tests (including PSL 2) shall have a secondary holding period of not less than 15 min. The hydrostatic test is performed to verify the pressure integrity of the housing pressure boundary.

The overall hydrostatic body-test pressure shall be determined by the lesser of either the rated working pressure of the housing's body or the high-pressure casing-string riser's pressure rating, or the pressure rating of innermost drill-through mudline casing-hanger that will be attached to the production casing string, as defined in Annex E. Typical pressure ratings for the hybrid casing hanger housing body are listed in Table 35.

**Table 35 — Mudline conversion tubing head assembly — Test pressure**

Rated working pressure		Hydrostatic body test pressure	
MPa	(psi)	MPa	(psi)
34,5	(5 000)	51,8	(7 500)
51,8	(7 500)	77,57	(11 250)
69,0	(10 000)	103,5	(15 000)

Hydrostatic factory acceptance testing of hybrid casing hanger housings is mandatory and shall be performed in accordance with 5.4.5. A dimensional check or drift test shall be performed on the housing to verify the minimum vertical bore; see Table 33.

## 11.4 Internal drill-through mudline casing hangers

### 11.4.1 General

Internal drill-through mudline casing hangers are installed on top of each casing string and support the string when landed in the hybrid casing hanger housing. They are configured to run through the surface BOP stack and high-pressure drilling riser, land inside the hybrid casing hanger housing and support the required casing load. They shall have provisions for an annulus seal assembly and support loads generated by BOP test pressures above the hanger and loads due to subsequent casing strings. Means shall be provided to transfer casing load and test-pressure load to the hybrid casing-hanger housing or to the previous casing hanger.

An external flowby area allows for returns to flow past the hanger during cementing operations and is designed to minimize pressure drop, while passing as large a particle size as possible. A pup joint of casing should be installed on the hanger in the shop. This reduces the risk of damage during handling.

Bodies of internal drill-through mudline casing hangers shall be treated as pressure-controlling parts as defined in ISO 10423.

**11.4.2 Design**

**11.4.2.1 Loads**

As a minimum, the following loads shall be considered and documented by the manufacturer when designing internal drill-through mudline casing hangers:

- suspended weight;
- overpull;
- pressure, internal and external;
- thermal;
- torsional;
- radial;
- impact.

**11.4.2.2 Threaded connections**

The type of casing threads on the hanger shall be as specified in ISO 10423.

**11.4.2.3 Vertical bore**

**11.4.2.3.1 Full opening vertical bore**

The minimum vertical bores for casing hangers shall be as given in Table 36. Equipment conforming to this requirement shall be referred to as having full-opening bores.

**11.4.2.3.2 Reduced opening vertical bores**

Reduced vertical bores may also be supplied.

**Table 36 — Minimum vertical bore sizes for casing hangers and wear bushings**

Casing OD		Minimum vertical bore	
mm	(in)	mm	(in)
178	(7)	153	(6,03)
194	(7 5/8)	172	(6,78)
219	(8 5/8)	195	(7,66)
244	(9 5/8)	217	(8,53)
273	(10 3/4)	242	(9,53)

**11.4.2.4 Outside profile**

The outside profile shall be in accordance with the manufacturer's written specification.



#### 11.4.2.5 Casing hanger ratings

The load and pressure ratings for casing hangers installed inside the wellhead can be a function of the tubular grade of material and wall section as well as the wellhead equipment in which it is installed. Manufacturers shall determine and document the load/pressure ratings for casing hangers as defined below.

##### a) Hanging capacity:

The manufacturer's stated hanging capacity rating for a casing hanger includes the casing thread (normally a female thread) cut into the hanger body.

##### b) Pressure rating:

- The manufacturer's stated pressure rating for a casing hanger includes the hanger body and the casing thread (normally a female thread) cut into the lower end of the hanger.
- The user is responsible for determining the working pressure of a given weight and grade of casing.

##### c) BOP test pressure:

The BOP test-pressure rating for a casing hanger is the maximum pressure that may be applied to the upper portion of the hanger body and to the annulus seal assembly. This rating specifically excludes the casing connection at the lower end of the casing hanger. The BOP test-pressure rating for a casing hanger shall be equal to the rated working pressure of the wellhead housing that the hanger is installed in.

##### d) Support capacity:

The manufacturer's stated support capacity is the rated weight that the casing hanger(s) are capable of transferring to the wellhead housing or previous casing hanger(s). The effects of full rated internal working pressure shall be included.

#### 11.4.2.6 Flowby area

Casing-hanger minimum flowby areas shall be documented by the manufacturer for each size of casing-hanger assembly.

### 11.4.3 Testing

#### 11.4.3.1 Validation testing

Validation testing of drill-through mudline casing hangers shall conform to 5.1.7. Validation testing for internal pressure shall be performed to verify the structural integrity of the hanger and shall be independent of the casing grade and thread.

#### 11.4.3.2 Factory acceptance testing

Hydrostatic testing is not required as part of the factory acceptance testing of drill-through mudline casing hangers. A dimensional check or drift test shall be performed on the hanger to verify the minimum vertical bore; see Table 36.

### 11.5 Annulus seal assemblies

#### 11.5.1 General

Annulus seal assemblies provide pressure isolation between each casing hanger and the wellhead housing. They may be run simultaneously with the subsea casing hanger, or separately. Annulus seal assemblies are actuated by various methods, including torque weight and/or hydraulic pressure.

Drill-through mudline annulus-seal assemblies shall be treated as pressure-controlling equipment as defined in ISO 10423.

## **11.5.2 Design**

### **11.5.2.1 Loads**

The following loads shall be considered and documented by the manufacturer when designing the annulus seal assemblies:

- setting loads;
- thermal loads;
- pressure loads;
- releasing and/or retrieval loads.

### **11.5.2.2 Rated working pressure**

The annulus seal assembly shall contain pressure from above equal to the rated working pressure of the casing hanger; see 11.4.2.5 b).

The manufacturer shall specify the rated working pressure from below if it is different than the rated working pressure from above.

### **11.5.2.3 Outside profile**

The outside profile shall be in accordance with the manufacturer's written specification.

### **11.5.2.4 Lockdown**

The annulus seal assembly shall be locked to the casing hanger and/or wellhead housing using a lock mechanism that allows retrieval without damage to the seal surfaces, in the event of seal failure.

### **11.5.2.5 Emergency annulus seal assemblies**

Emergency annulus seal assemblies that position the seal in a different area or use a different seal mechanism may be supplied. They shall meet all requirements of 11.5.2.

## **11.5.3 Factory acceptance testing**

Factory acceptance testing is not required.

## **11.6 Bore protectors and wear bushings**

### **11.6.1 General**

A bore protector protects annulus-seal assembly sealing surfaces inside the hybrid casing-hanger housing before internal drill-through mudline casing hangers are installed. After a casing hanger is run, a correspondingly sized wear bushing is installed to protect the remaining annular sealing surfaces and the previously installed annular seal assemblies and casing hangers. They are generally not pressure-retaining devices. However, wear bushings may be designed for BOP-stack pressure-test loading.

## 11.6.2 Design

### 11.6.2.1 Loads

The following loads shall be considered and documented by the manufacturer when designing the bore protectors or wear bushings:

- BOP test pressure loading;
- radial loads.

It is not necessary for bore protectors or wear bushings to meet the requirements of Clause 5.

### 11.6.2.2 Vertical bores

#### 11.6.2.2.1 Full opening vertical bore

The minimum vertical bore of the bore protector shall be as given in Table 37. The minimum vertical bore through wear bushings shall be as given in Table 36. Bore protectors and wear bushings conforming to these requirements shall be referred to as having full-opening bores.

#### 11.6.2.2.2 Reduced opening vertical bore

Reduced vertical bores may also be supplied.

**Table 37 — Minimum vertical bores for bore protectors**

Nominal BOP stack sizes		Minimum vertical bore	
mm	(in)	mm	(in)
346	(13 5/8)	312	(12,31)

#### 11.6.2.3 Outside profile

The outside profile shall be in accordance with the manufacturer's written specifications.

#### 11.6.2.4 Rated working pressure

Bore protectors and wear bushings are not normally designed to retain pressure.

#### 11.6.2.5 Lockdown/anti-rotation

Means shall be provided to restrain or lock the wear bushings or bore protector within the housing. This feature may also be designed to minimize rotation.

### 11.6.3 Materials

The materials used in bore protectors and wear bushings shall comply with the manufacturer's written specifications.

### 11.6.4 Testing

Bore protectors and wear bushings shall be dimensionally inspected to confirm minimum vertical bore.

## 11.7 Tubing hanger system — Drill-through mudline equipment for subsea completions

All design, materials and testing of the tubing hanger system shall be in accordance with Clause 9.

## 11.8 Abandonment caps

### 11.8.1 Description

Abandonment caps are typically not provided for drill-through mudline equipment, as it is assumed that the well will be fully completed after drilling.

## 11.9 Running, retrieving and testing tools

Tools for running, retrieving and testing all drill-through mudline wellhead components, including guidance equipment, housings, casing suspension equipment, annulus sealing equipment and protective devices, are beyond the scope of this part of ISO 13628.

See Annex H for recommended guidelines for the design and testing of this equipment.

Wash ports may be provided in the running tools to allow for cleaning of cement from around the previously run hanger/housing.

STANDARDSISO.COM : Click to view the full PDF of ISO 13628-4:2010

## Annex A (informative)

### Vertical subsea trees

Vertical subsea trees are installed either on the wellhead or on a tubing head, after the subsea tubing-hanger has been installed through the drilling BOP stack and landed and locked into the wellhead or tubing head. The production flow path is through the valves mounted in the vertical bore(s) and either out of the top of the tree during workover and testing [in special applications production (injection) may be via the top of the tree] and during production (injection) via the production outlet that branches off the vertical bore.

The subsea tree may have a concentric bore or may have multiple bores. Annulus access may be through one of the tree bores or it may be through a side outlet in the tubing head, below the tubing hanger.

The production outlet may be at 90° to the production bore or may be angled to best suit flow requirements. In TFL trees, the outlets are swept in at 15° maximum to the production bore to facilitate the passage of pump down tools.

Figures A.1 through A.3 illustrate the major items of equipment in vertical subsea trees. The arrangements shown are typical and should not be construed as requirements.

Major items of equipment in a subsea tree are

- completion guidebases and tubing head;
- tree wellhead connector;
- tree stabs and seal subs;
- valves, valve blocks and valve actuators;
- TFL wye spool;
- tree re-entry interface;
- tree cap;
- tree-cap running tool;
- tree piping;
- tree guide frame;
- tree running tool;
- flowline connectors;
- flowline-connector support frame;
- subsea chokes and actuators;
- tree-mounted control interfaces;
- control pod interface.

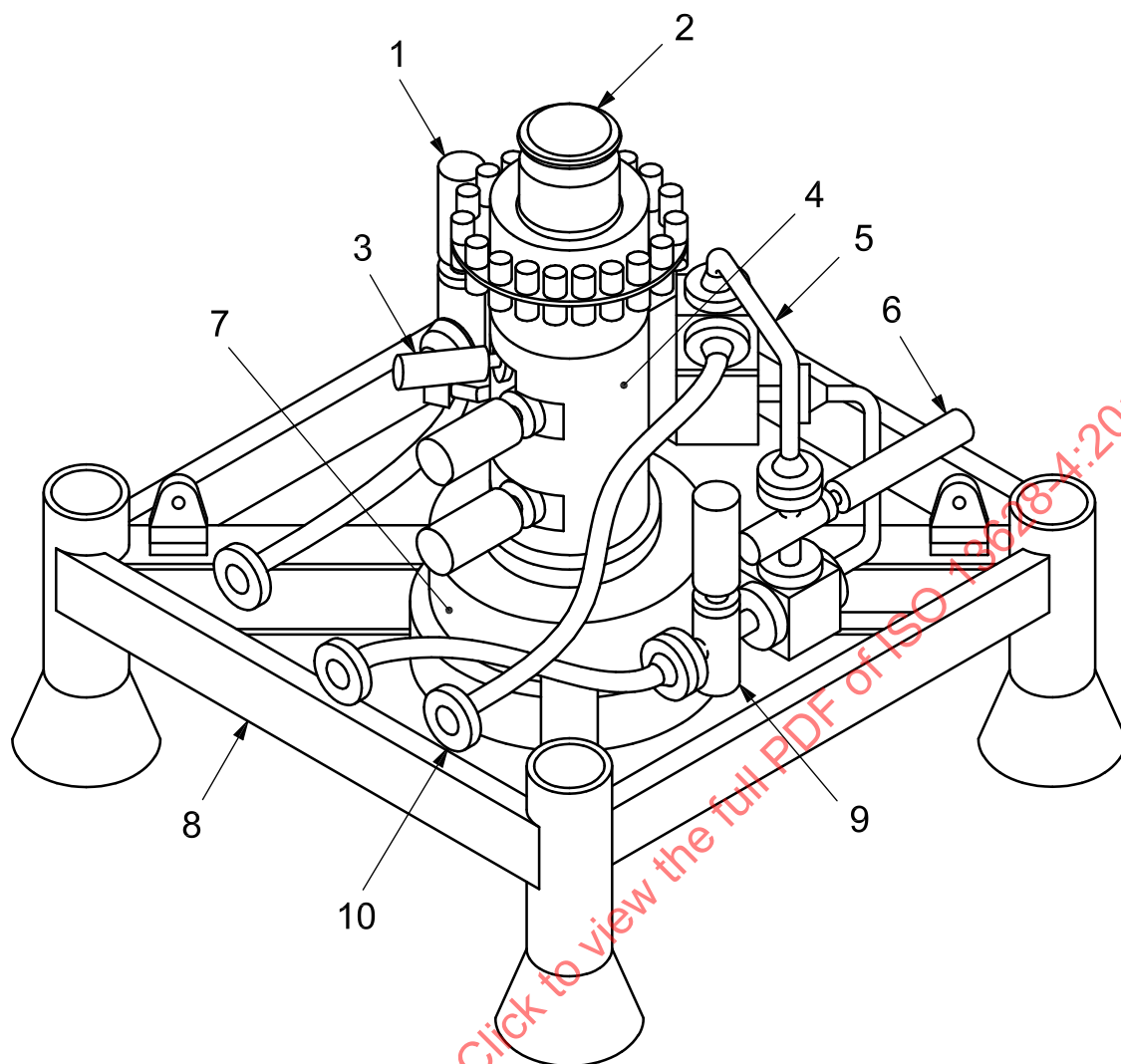

**Key**

- |   |                       |    |                      |
|---|-----------------------|----|----------------------|
| 1 | production wing valve | 6  | crossover valve      |
| 2 | tree cap              | 7  | tree connector       |
| 3 | production swab valve | 8  | tree guide frame     |
| 4 | master valve block    | 9  | annulus wing valve   |
| 5 | flow loop             | 10 | flow line connection |

**Figure A.1 — Guideline style vertical tree**

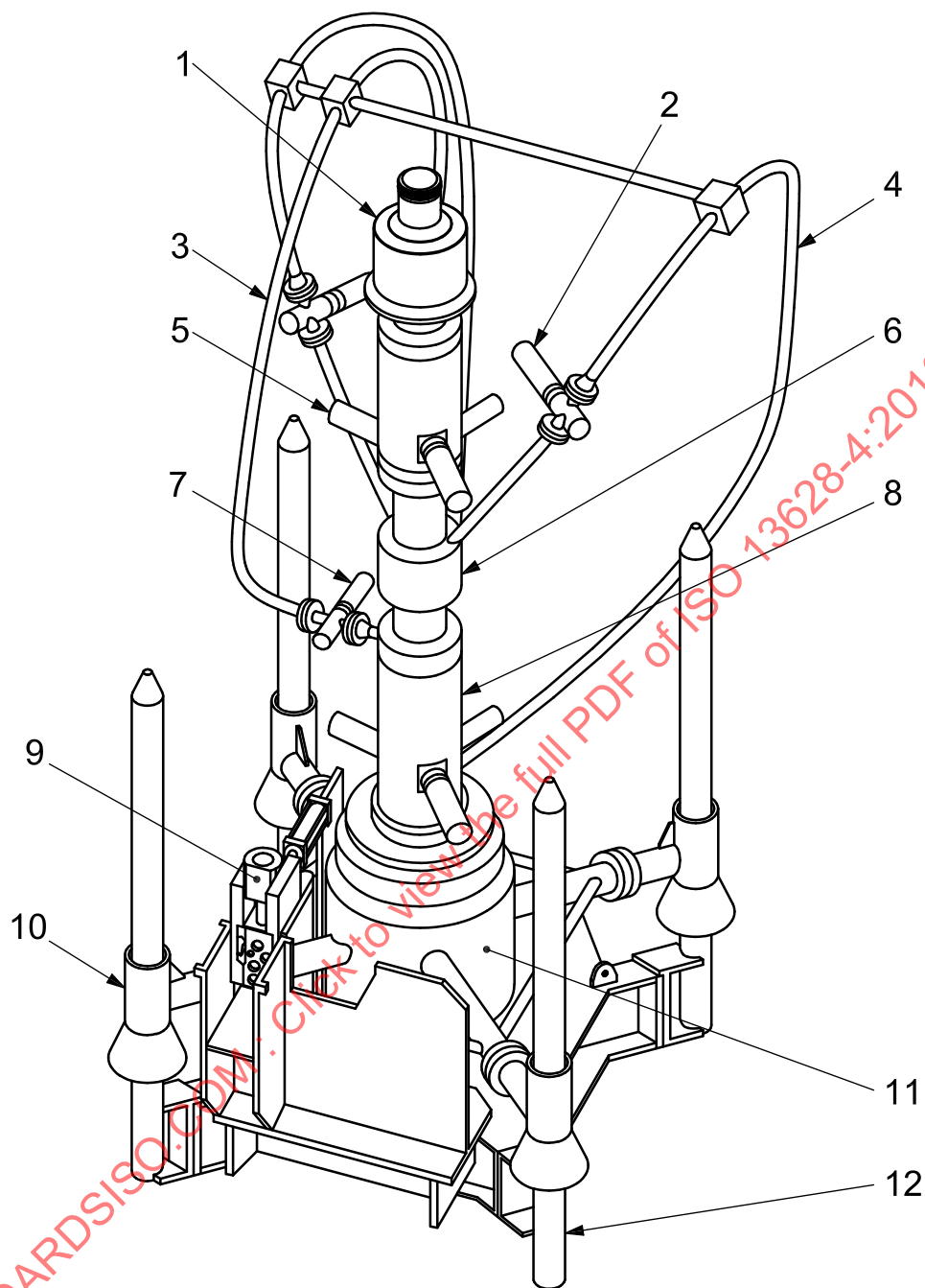

**Key**

- |                     |                          |                       |
|---------------------|--------------------------|-----------------------|
| 1 tree cap assembly | 5 swab valves            | 9 flow line connector |
| 2 wing valve        | 6 wye spool and diverter | 10 tree guide frame   |
| 3 annulus loop      | 7 annulus wing valve     | 11 tree connector     |
| 4 TFL flow loop     | 8 master valve block     | 12 wellhead guidebase |

**Figure A.2 — Guideline style TFL tree**

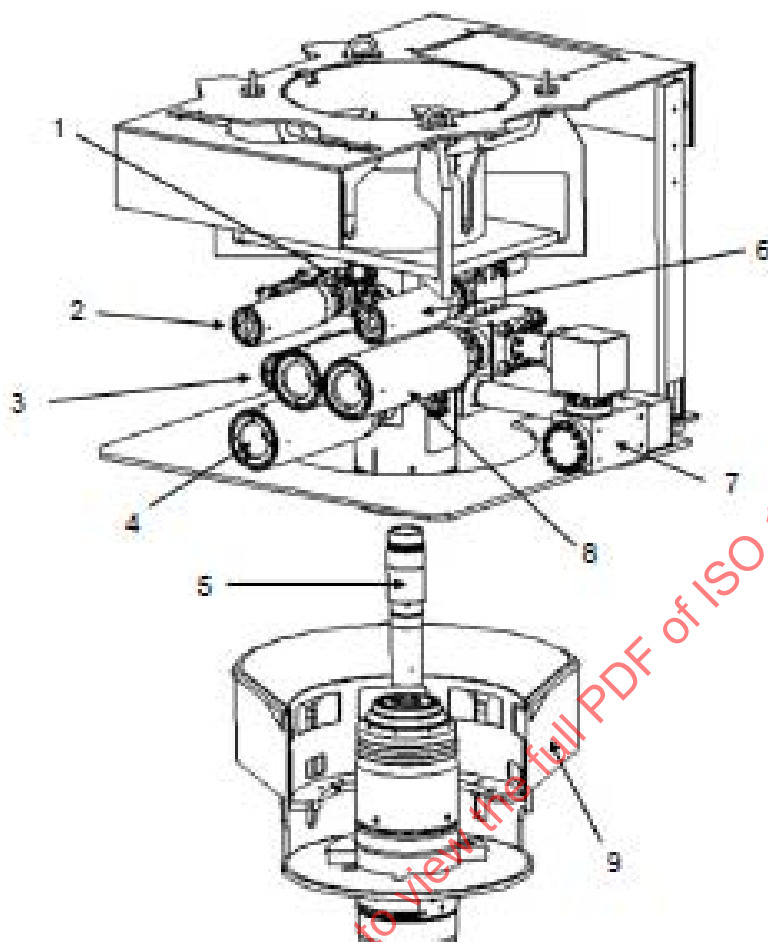

**Key**

- |                        |                     |                            |
|------------------------|---------------------|----------------------------|
| 1 swab valves          | 5 tubing hanger     | 9 GRA, CGB, or tubing head |
| 2 annulus wing valve   | 6 crossover valve   |                            |
| 3 annulus master valve | 7 production outlet |                            |
| 4 master valve         | 8 wing valve        |                            |

**Figure A.3 — Guidelineless style vertical tree**



## Annex B (informative)

### Horizontal subsea trees

Several options are available for horizontal tree arrangements. These offer different benefits for installation, retrieval and maintenance. These are addressed for information only. No attempt is made within this part of ISO 13628 to evaluate or recommend an option.

Horizontal subsea trees may be installed after drilling and installation of the complete wellhead system and prior to installation of the tubing completion and tubing hanger. For this mode of operation, the BOP is installed on top of the horizontal subsea tree and the tubing hanger and tubing completion is run through the BOP and landed off on a landing shoulder in the bore of the horizontal subsea tree. The production flow path exits horizontally through a branch bore in the tubing hanger between seals and connects to the aligned production outlet. A typical tree of this type is illustrated in Figure B.1. The arrangement shown in Figure B.1 requires that the tubing completion be retrieved prior to retrieving the tree. The arrangement also includes a pressure-containing internal tree cap above the tubing hanger to provide a second barrier.

In an alternative arrangement, the tubing hanger and internal tree cap are combined into a single extended tubing hanger system suspended in the horizontal tree. It doubles up on the number of isolation plugs and annular seals for barrier protection and features a debris cap that can also serve as a back-up locking mechanism for the tubing hanger.

A guidelineless version of the horizontal tree, which is typically a funnel down arrangement, is shown in Figure B.2. The extended neck on top of the tree is required for clearance for the BOP's re-entry funnel and "swallow" of its connector.

A third configuration, generally referred to as the "drill-through" horizontal tree, allows the installation of the horizontal tree immediately after the wellhead housing is landed. This system allows carryout of the drilling and installation of casing strings through the horizontal tree, minimizing the number of times it is necessary to run and retrieve the BOP stack. In this configuration, the diameter of the tree-bore protector and tubing-hanger orientation system should drift the casing hanger and seal assembly.

Horizontal trees may also be used with mudline suspension equipment and drill-through mudline suspension equipment and may, additionally, be configured for artificial lift completions, such as electric submersible pumps or hydraulic submersible pumps.

Horizontal subsea trees use many of the same items of equipment as vertical trees. However, equipment that differs significantly includes the:

- tree body;
- tubing hanger;
- isolation plugs (left in place);
- tree cap.



Common names for individual components are included in the numbered key. The two items not identified are the casing hangers (blue) and tree (yellow).

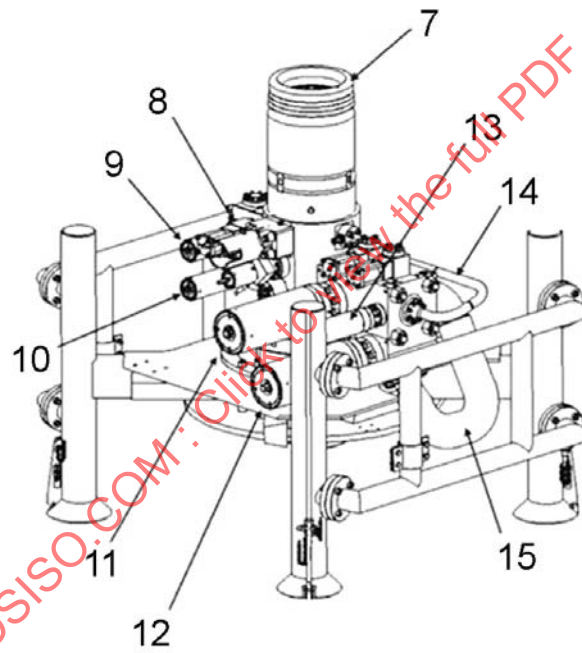

**Key**

- |                      |                          |                       |
|----------------------|--------------------------|-----------------------|
| 1 crown plugs        | 6 extended tubing hanger | 11 master valve       |
| 2 debris cap         | 7 re-entry interface     | 12 wing valve         |
| 3 internal tree cap  | 8 annulus swab valve     | 13 crossover valve    |
| 4 tubing hanger      | 9 annulus wing valve     | 14 crossover flowloop |
| 5 locking debris cap | 10 annulus master valve  | 15 production outlet  |

**Figure B.1 — Guideline style horizontal tree**

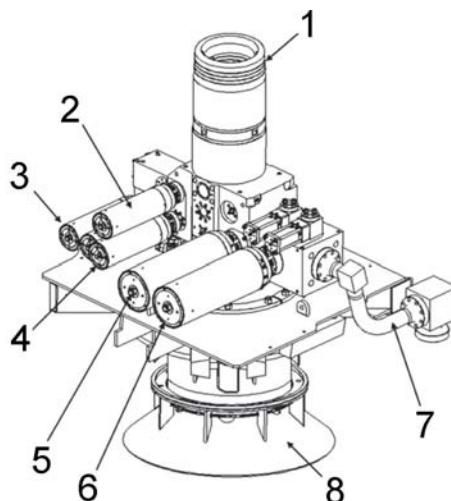
**Key**

- |   |                      |   |   |
|---|----------------------|---|---|
| 1 | re-entry interface   | 5 | master valve                                |
| 2 | annulus swab valve   | 6 | wing valve                                  |
| 3 | annulus wing valve   | 7 | production outlet                           |
| 4 | annulus master valve | 8 | guidelineless re-entry funnel (funnel down) |

**Figure B.2 — Guidelineless style horizontal tree**

## Annex C (informative)

### Subsea wellhead

The subsea wellhead is normally run from a floating drilling rig and is located at the mudline. It supports the casing strings and seals off the annuli between them. It is used in conjunction with a subsea BOP stack that locks and seals to the high-pressure wellhead housing. The subsea tree locks and seals to the high-pressure housing after drilling is complete. Figure C.1 illustrates the items of equipment used in a subsea wellhead.

Subsea wellhead systems can be run with a TGB/PGB (guideline) TGB/GRA (guidelineless) or without (guidelineless), and can incorporate alternative means of orientation, if required.

Subsea wellheads may be used for subsea completions or tied back to a surface completion.

Major items of equipment used with subsea wellhead are:

- TGB;
- PGB or GRA;
- conductor housing;
- wellhead housing;
- casing hangers;
- seal assemblies (packoffs, emergency packoffs, lockdown bushings);
- bore protectors and wear bushings;
- corrosion caps;
- running tools.

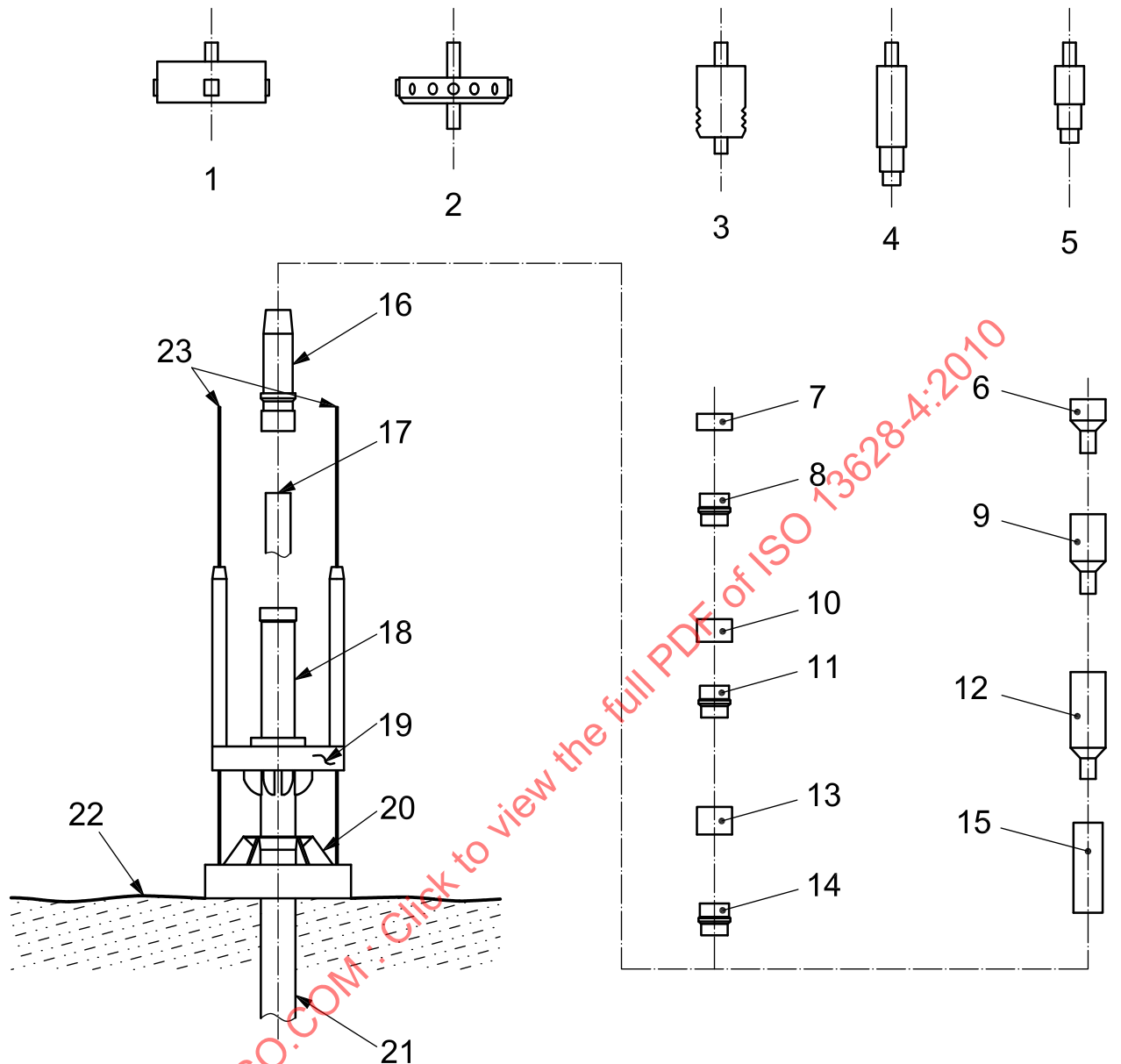

### Key

- |    |  |    |   |
|----|--|----|---|
| 1  | temporary guidebase running tool                             | 12 | 340 mm (13-3/8 ) wear bushing                             |
| 2  | 762 mm (30 in) housing running tool                          | 13 | 508 mm × 340 mm (20 in × 13-3/8 in) annulus seal assembly |
| 3  | high-pressure housing running tool                           | 14 | 340 mm (13-3/8 ) casing hanger                            |
| 4  | casing hanger running tool (drillpipe or fullbore)           | 15 | housing bore protector                                    |
| 5  | test tool  | 16 | high-pressure wellhead housing                            |
| 6  | 178 mm (7 in) wear bushing                                   | 17 | surface casing [normally 508 mm (20 in)]                  |
| 7  | 245 mm × 178 mm (9-5/8 in × 7 in) annulus seal assembly      | 18 | low-pressure conductor hsg [normally 762 mm (30 in)]      |
| 8  | 178 mm (7 in) casing hanger                                  | 19 | permanent guidebase                                       |
| 9  | 245 mm (9-5/8 in) wear bushing                               | 20 | temporary guidebase                                       |
| 10 | 340 mm × 245 mm (13-3/8 in × 9-5/8 in) annulus seal assembly | 21 | 762 mm (30 in) conductor casing                           |
| 11 | 245 mm (9-5/8 in) casing hanger                              | 22 | seafloor  |
|    |  | 23 | guidelines  |

Figure C.1 — Subsea wellhead

## Annex D (informative)

### Subsea tubing hanger

Subsea tubing hangers are located in the wellhead, tubing head (wellhead conversion assembly) or horizontal tree.

They suspend the tubing, seal off the production and provide sealing pockets for the production and control stabs as a minimum. Horizontal trees also have annular seals for the horizontal side outlets.

Tubing hangers having multiple bores require orientating relative to the PGB to ensure that the tree engages with the tubing hanger when installed. It is normal to orientate tubing hangers with horizontal production outlets to give a smooth flow passage between the tubing hanger and horizontal tree. Concentric tubing hangers do not necessarily require orientation, unless required as a consequence of providing downhole instrumentation.

After installation, the tubing hanger is locked into the mating wellhead, tubing head, etc., to resist the force due to pressure in the production casing and to resist thermal expansion. Lock mechanisms may be mechanically or hydraulically actuated depending on water depth and specific project requirements.

Major elements of the tubing hanger system are

- tubing hanger:
  - concentric; see Figure D.1;
  - multiple bores; see Figure D.2;
  - horizontal tree; see Figure D.3;
  - horizontal tree, extended; see Figure D.4;
- tubing hanger running tool;
- orientation device;
- miscellaneous tools.

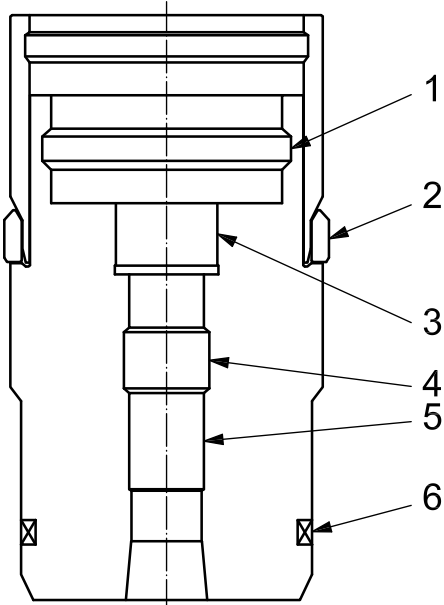

**Key**

- 1 running tool latching groove
- 2 lockdown
- 3 stab sub seal pockets
- 4 wireline plug profiles
- 5 production bore
- 6 seal

**Figure D.1 — Concentric tubing hanger**

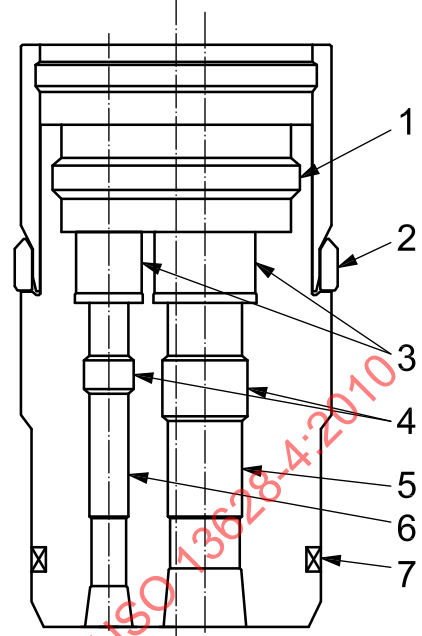

**Key**

- 1 running tool latching groove
- 2 lockdown
- 3 stab sub seal pockets
- 4 wireline plug profiles
- 5 production bore
- 6 annulus bore
- 7 seal

**Figure D.2 — Tubing hanger with multiple bores**

STANDARDSISO.COM : Click to view the full PDF of ISO 13628-4:2010

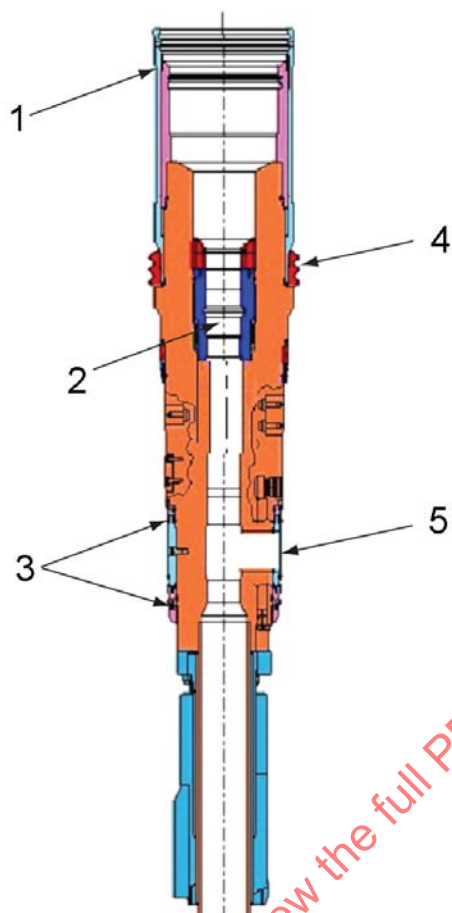

Common names for individual components are included in the numbered key. The two items not identified are the casing hangers (blue) and tree (yellow).

**Key**

- 1 running tool latching groove
- 2 wireline plug profile or closure device
- 3 seal
- 4 lockdown
- 5 production outlet

**Figure D.3 — Tubing hanger for horizontal tree**



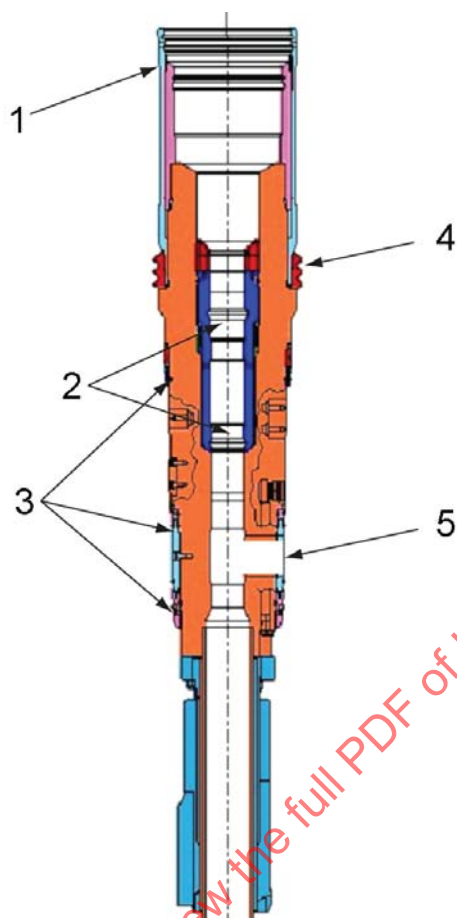

Common names for individual components are included in the numbered key. The two items not identified are the casing hangers (blue) and tree (yellow).

#### Key

- 1 running-tool latching groove
- 2 wireline plug profile or closure devices, two
- 3 seal
- 4 lockdown
- 5 production outlet

Figure D.4 — Extended tubing hanger for horizontal tree

## Annex E (normative)

### Mudline suspension and conversion systems

#### E.1 General

Mudline suspension equipment is used to suspend casing weight at or near to the mudline, to provide pressure control and to provide annulus access to the surface wellhead. Mudline equipment is used when drilling with a bottom-supported rig or platform and provides for drilling, abandonment, platform tieback completion and subsea completion. During drilling/workover operations, the BOP is located at the surface. The casing annuli are not sealed at the mudline suspension; therefore, it is necessary to install mudline conversion equipment prior to installing a tubing completion and subsea tree.

Tieback adapters, mudline conversion equipment and tubing heads are used to provide a preparation to accept the tubing hanger and a profile to which a subsea tree can be locked and sealed.

Major items of equipment used with mudline equipment are:

- landing and elevation ring;
- casing hangers;
- casing hanger running tools and tieback adapters;
- abandonment caps;
- mudline conversion equipment;
- mudline conversion tubing head.

Figure E.1 illustrates the items of equipment used in mudline suspension and conversion equipment.

#### E.2 Calculation of pressure ratings for mudline suspension equipment

##### E.2.1 Introduction

The purpose of this annex is to define methods for calculating rated working pressure and test pressure for mudline equipment that are consistent with accepted engineering practice. Mudline equipment design is a unique combination of tubular goods and hanger equipment and, therefore, it is not intended that these methods and allowable stresses be applied to any other type of equipment. Fatigue analysis, thermal expansion considerations and allowable values for localized bearing stress are beyond the scope of these rated working pressure calculations.

As an alternative to the method presented in this annex, the designer may use the rules in ASME *BPVC*, Section IX,<sup>[13]</sup> Annex 4, modified in accordance with ISO 10423. In this case, bending stresses in wall-section discontinuities can be treated as secondary stresses. However, when using this alternative method, the calculation for the rated working pressure shall be made in combination with loads applied by the rated running capacity (if applicable) and the rated hanging capacity as well as thermal loads. The designer shall ensure that strains resulting from these higher allowable stresses do not impair the function of the component, particularly in seal areas.

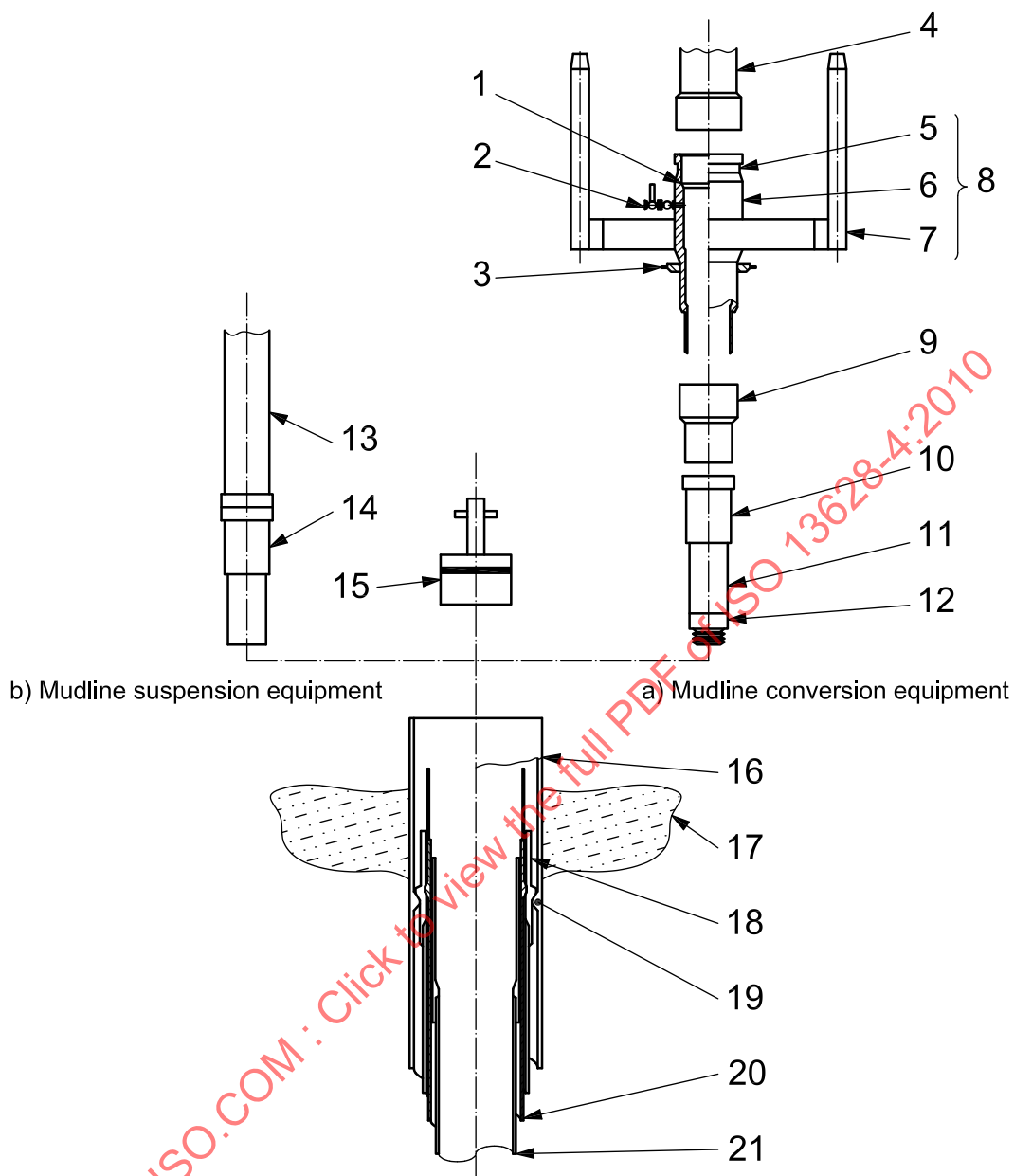

**Key**

- |    |                                    |    |  |
|----|------------------------------------|----|--|
| 1  | tubing hanger profile              | 12 | tieback tool (tieback sub)   |
| 2  | annulus outlet                     | 13 | casing riser (to jack up)  |
| 3  | structural support ring (optional) | 14 | casing hanger running tools (landing subs) or tieback tools (tieback subs) |
| 4  | workover completion riser          | 15 | abandonment cap  |
| 5  | connector profile                  | 16 | 762 mm (30 in) conductor casing  |
| 6  | wellhead adapter                   | 17 | mudline  |
| 7  | permanent guidebase                | 18 | 508 mm (20 in) casing hanger   |
| 8  | tubing heads                       | 19 | 762 mm (30 in) landing ring  |
| 9  | annulus seal assembly              | 20 | 340 mm (13-3/8 in) casing hanger   |
| 10 | tieback adapter                    | 21 | 245 mm (9-5/8 in) casing hanger  |
| 11 | casing                             |    |  |

**Figure E.1 — Mudline suspension (wellhead) and conversion equipment**

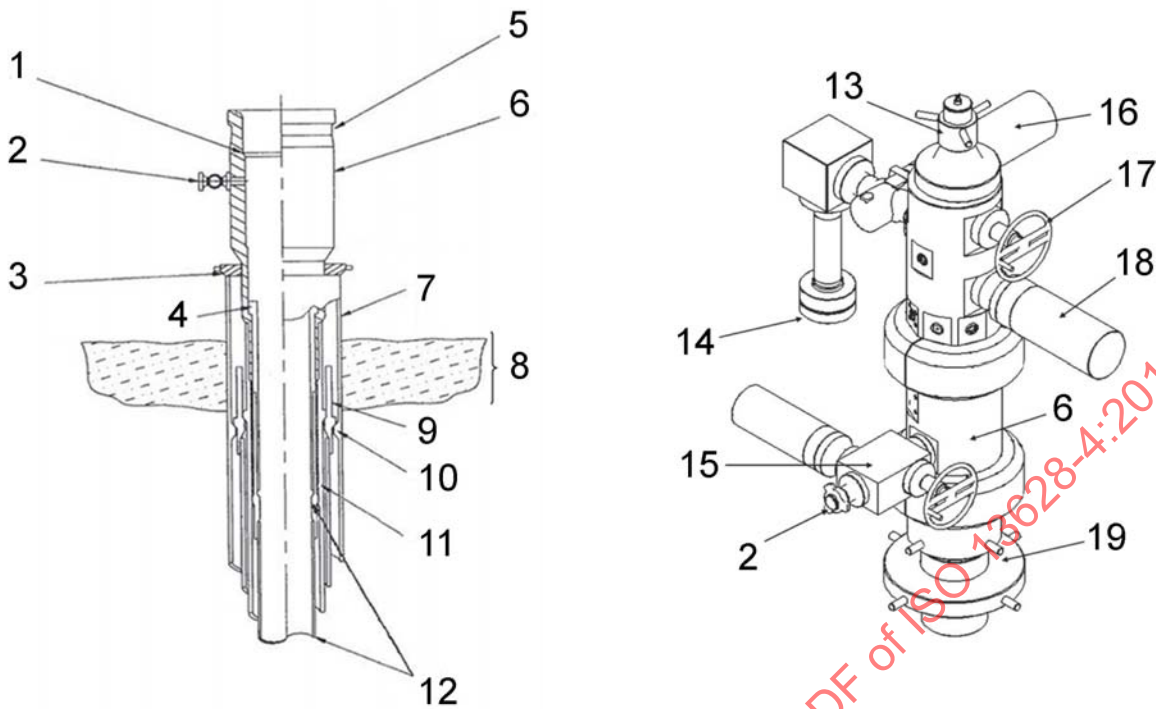

a) Mudline conversion equipment (installed)

b) Subsea tree on a mudline suspension conversion

**Key**

- |    |                                       |    |   |
|----|---------------------------------------|----|---|
| 1  | tubing hanger profile                 | 11 | mudline casing hanger, 340 mm (13-3/8 in) |
| 2  | annulus outlet                        | 12 | mudline casing hanger, 245 mm (9-5/8 in)  |
| 3  | structural support ring (optional)    | 13 | tree cap                                  |
| 4  | casing hanger tieback adapter         | 14 | production outlet                         |
| 5  | connector profile                     | 15 | annulus valves                            |
| 6  | tubing head                           | 16 | wing valve                                |
| 7  | conductor casing, 762 mm (30 in)      | 17 | swab valve                                |
| 8  | mudline                               | 18 | master valve                              |
| 9  | mudline casing hanger, 508 mm (20 in) | 19 | mudline conversion                        |
| 10 | mudline landing ring, 762 mm (30 in)  |    |   |

**Figure E.2 — Mudline conversion equipment**

**E.2.2 Determination of applied loads**

For each component that is considered in the rating, the most highly stressed region in the component when subjected to the worst case combination of internal pressure and pressure end load shall be established. In performing this assessment, bending and axial loads other than those induced by the pressure end caps and threaded end connections required for imposition of pressure end load may be ignored. Specifically, it is not necessary to consider axial or bending loads caused by the connection of the component to other pieces of equipment in service.

In establishing the most highly stressed region of the component, considerable care shall be used to ensure that loads applied through any casing threads which are machined into the component are included. The presence of threads cut into the wall of a component and the pressure end loads imparted to the main body of the component through these threads results in local bending stress which shall be considered. The general

shape of the main body of the component may also result in section bending stress, especially when pressure end load is added. These shape effects shall also be considered when determining the loads on the component.

### E.2.3 Determination of stresses

After the location of the highest stress for any given component and loading condition have been determined, the stress distribution across the critical section shall be linearized to establish the membrane stress,  $S_m$ , the local bending stress,  $S_b$ , and peak stress,  $F$ , in the section; see Figure E.3 (see ISO 13625). The linearization operation shall be performed on each component of stress. The individual linearized components shall then be used to calculate a von Mises equivalent stress through the cross-section. The von Mises equivalent stress or distortion energy stress,  $S_e$ , shall be calculated as given in Equation (E.1):

$$S_e = \left[ S_x^2 + S_y^2 + S_z^2 - S_x S_y - S_x S_z - S_y S_z + 3(S_{xy}^2 + S_{xz}^2 + S_{yz}^2) \right]^{1/2} \quad (\text{E.1})$$

where

$S_x, S_y, S_z$  are the component normal stresses at a point;

$S_{xy}, S_{xz}, S_{yz}$  are the component shear stresses at a point;

subscripts  $x, y$  and  $z$  refer to the global coordinate system.

The linearization operation can be done by hand calculation but it is more often done using a computer program. If a computer program or FEA post-processing program is used, caution shall be used to verify that the program is calculating the linearization stresses correctly. A check on computer output is highly recommended. One such simple check for FEA post-processing programs is to construct an FEA model of a simple beam in four-point bending. This model should be analysed for plane strain conditions and should have a beam depth made up of at least five elements. The linearized von Mises stress through the centre section of such a beam should produce no von Mises membrane stress.

The von Mises stress values of interest in the cross section of the component being studied are the linearized membrane (net section) stress, and the linearized local bending stress as shown in Figure E.3. These values consider the multiaxial stress condition at a point since they are von Mises equivalent stresses.

### E.2.4 Allowable stress levels for working and test conditions

The allowable stress levels for test and working conditions are based on percentages of membrane-plus-bending and membrane-only stress required to yield the material. For the case of the stresses used in this, the local membrane and bending stress calculated in E.2.3 shall be considered primary stresses since they are the stresses required to provide static equilibrium of the section with the applied pressure and end loads.

In order to understand what allowable levels should be used for this case, the limiting situation of full section yielding shall be defined. Assuming the simple case of a rectangular beam and an elastic/perfectly plastic material, a plot of limiting membrane-plus-bending versus membrane-only stress can be made (see ASME *BPVC*, Section III<sup>[9]</sup> and ASME *BPVC*, Section VIII<sup>[12]</sup>). Figure E.4 shows the limiting values of various combinations of membrane-plus-bending and membrane-only stresses normalized using the minimum specified material yield strength,  $S_Y$ . The limit stress ratio for membrane only is 1,0 and for bending only the limit is 1,5. If a membrane stress less than  $2/3 S_Y$  is added to a large bending stress, the membrane-plus-bending stress ratio may exceed 1,5. This is due to the stiffening effect of the membrane stress and shifting of the beam's neutral axis. This increase in bending capacity when axial load is applied is generally ignored.

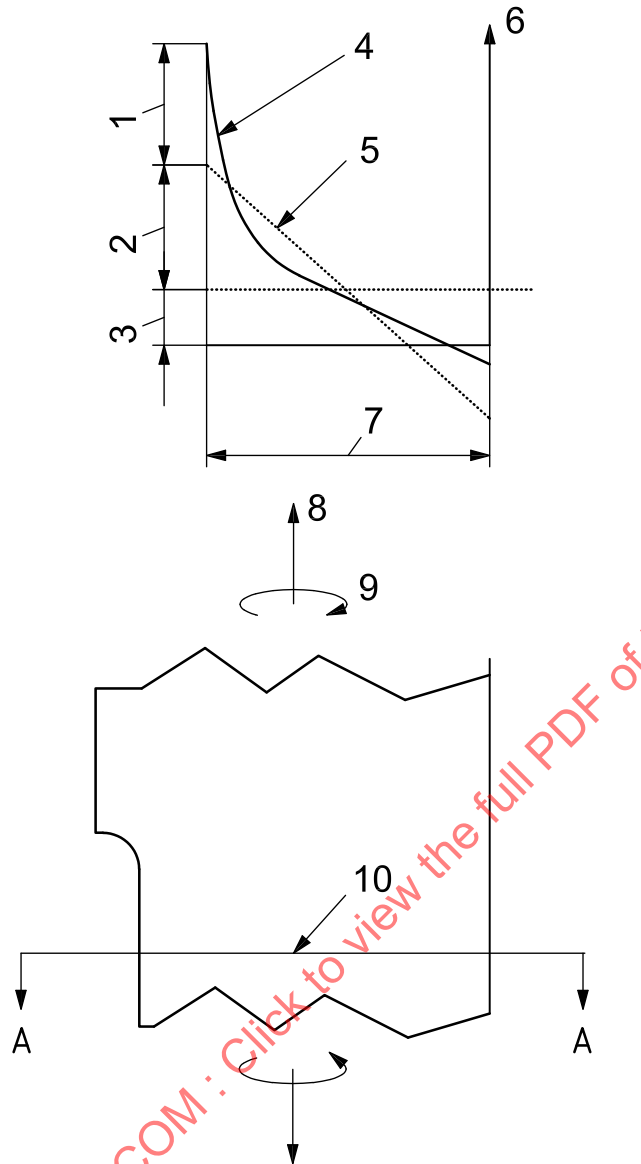

**Key**

- |   |                                  |    |  |
|---|----------------------------------|----|--|
| 1 | local peak stress, $F$           | 6  | stress                                   |
| 2 | local bending stress, $S_b$      | 7  | thickness                                |
| 3 | net section member stress, $S_m$ | 8  | tensile load                             |
| 4 | total stress distribution        | 9  | local bending moment                     |
| 5 | equivalent linear distribution   | 10 | vertical plane through axisymmetric part |

**Figure E.3 — Stress distribution, axi-symmetric cross-section, mudline suspension components**

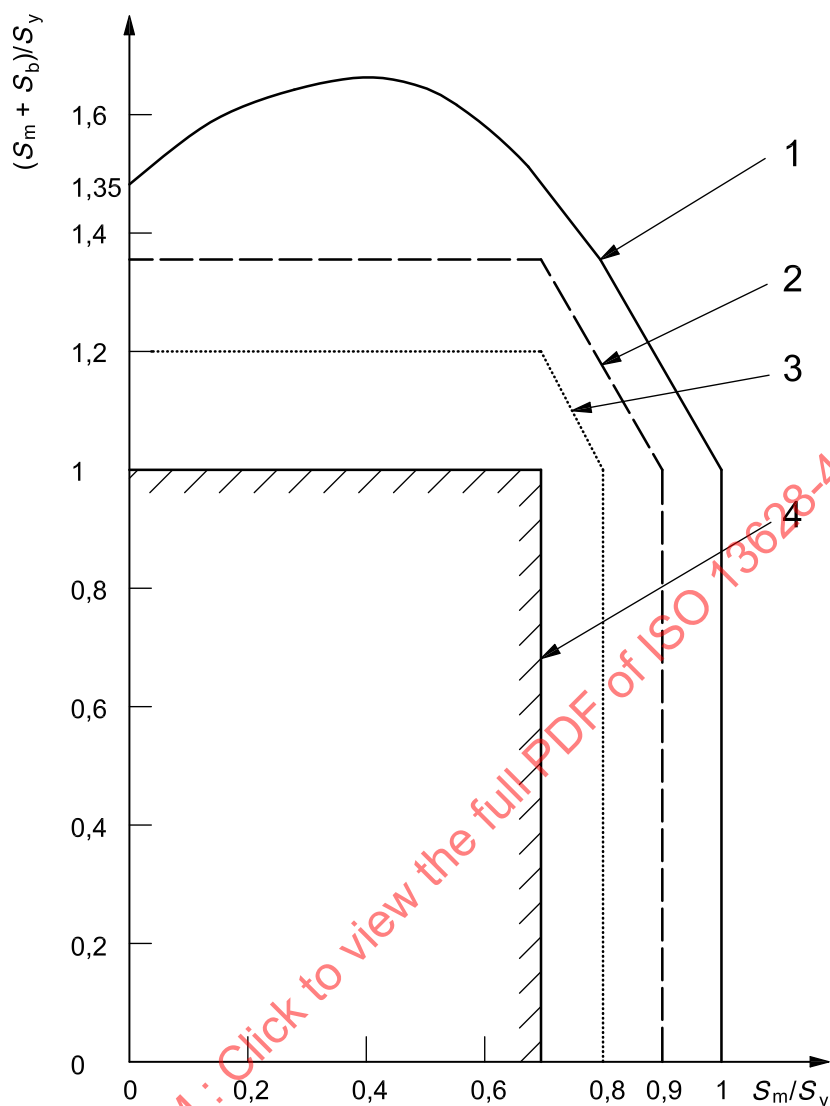
**Key**

$S_m$ membrane stress	1	limit stress
$S_b$ bending stress	2	test pressure limit
$S_Y$ yield strength	3	rated working pressure for suspension equipment
	4	rated working pressure for conversion equipment

**Figure E.4 — Limiting stress values, mudline suspension components**

**E.2.5 Test pressure**

For the purposes of this part of ISO 13628, the allowable von Mises stresses for hydrostatic test conditions on both suspension and conversion equipment are as follows: the membrane stress,  $S_m$ , as given in Inequality (E.2) and the membrane-plus-bending stress,  $S_m + S_b$ , as given in Inequality (E.3) for  $S_m < 0,67S_Y$  and as given in Inequality (E.4),  $1,2 S_m$  for  $0,67S_Y < S_m < 0,90S_Y$ :

$$S_m < 0,90S_Y \quad (\text{E.2})$$

$$S_m + S_b < 1,35S_Y \quad (\text{E.3})$$

$$S_m + S_b < 2,15S_Y \quad (\text{E.4})$$

The allowable test pressure shall be that required to cause any of the allowable stresses to occur in the critical cross-section of the component when pressure and end loads due to test end caps or plugs are considered. It is mentioned that the above limits, shown in Figure E.4 for clarity, are identical to those given in ASME *BPVC*, Section VIII [12], Part AD, for hydrostatic test conditions.

## E.2.6 Rated working pressure

### E.2.6.1 Mudline suspension equipment

For the purposes of this part of ISO 13628, the allowable von Mises stresses for working conditions for mudline suspension equipment are as follows: the membrane stress,  $S_m$ , as given in Inequality (E.5) and the membrane-plus-bending stress,  $S_m + S_b$ , as given in Inequality (E.6) for  $S_m < 0,67S_Y$  and as given in Inequality (E.7),  $1,2 S_m$  for  $0,67S_Y < S_m < 0,80S_Y$ :

$$S_m < 0,80S_Y \quad (E.5)$$

$$S_m + S_b < S_Y \quad (E.6)$$

$$S_m + S_b < 2,004S_Y \quad (E.7)$$

The rated working pressure shall be that required to cause these stresses to occur in the critical cross-section of the component being considered. These limits are about 90 % of test conditions.

### E.2.6.2 Mudline conversion equipment

For the purposes of this part of ISO 13628, the allowable von Mises stresses for working conditions for mudline conversion equipment are as follows: the membrane stress,  $S_m$ , as given in Inequality (E.8) and the membrane-plus-bending stress,  $S_m + S_b$ , as given in Inequality (E.9):

$$S_m < 0,67S_Y \quad (E.8)$$

$$S_m + S_b < S_Y \quad (E.9)$$

The rated working pressure shall be that required to cause these stresses to occur in the critical cross-section of the component being considered. These limits are about 75 % of test conditions. The conditions coincide with the normal design stress limit given in Reference [12]. It should be mentioned that the membrane stress limit for the conversion-equipment operating condition is more conservative than that for suspension equipment. This is to account for the fact that the suspension equipment is used in service as a part of the casing string. Casing string components typically have higher allowable stress limits than completion or production equipment.



## Annex F (informative)

### Drill-through mudline suspension systems

Drill-through mudline suspension equipment is used to suspend casing weight at or near to the mudline and to provide pressure control. Drill-through mudline suspension equipment is used when drilling with a bottom-supported rig when it is anticipated that the well can be completed subsea. During drilling, workover and completion operations, the BOP is located at the surface. The system differs from mudline suspension in that the surface casing is suspended from a wellhead housing and subsequent casing strings use wellhead-like hangers and annulus seal assemblies. The hangers have positive landing shoulders; therefore their OD is normally too large to allow running them through casing tiebacks. It is usual to use risers having a pressure rating and bore equivalent to the surface BOP for the installation of casing hangers, seal assemblies, internal abandonment caps and tubing hangers. The wellhead housing contains the necessary profile for locking down the tubing hanger and has an external profile to which the subsea tree can be locked; therefore drill-through mudline requires no conversion equipment.

Major items of equipment used with drill-through mudline suspension are the:

- conductor housing;
- surface casing hanger;
- wellhead housing;
- casing hangers;
- annulus seal assemblies;
- bore protectors and wear bushings;
- abandonment caps;
- running, retrieving and test tools.

Figure F.1 illustrates the items of equipment used in drill-through mudline suspension systems.

**Key**

- 1 casing, 244 mm to 273 mm (9 5/8 in to 10 3/4 in)
- 2 riser, 406 mm (16 in)
- 3 riser, 610 mm (24 in)
- 4 environmental tie-back pipe
- 5 guidance equipment
- 6 abandonment cap
- 7 connector profile
- 8 wellhead housing
- 9 seal assembly
- 10 production casing hanger
- 11 hanger, 473 mm to 508 mm (18 5/8 in to 20 in)
- 12 conductor housing
- 13 conductor, 762 mm (30 in)
- 14 casing, 473 mm to 508 mm (18 5/8 in to 20 in)
- 15 casing, 340 mm (13 3/8 in)
- 16 casing, 244 mm to 273 mm (9 5/8 in to 10 3/4 in)

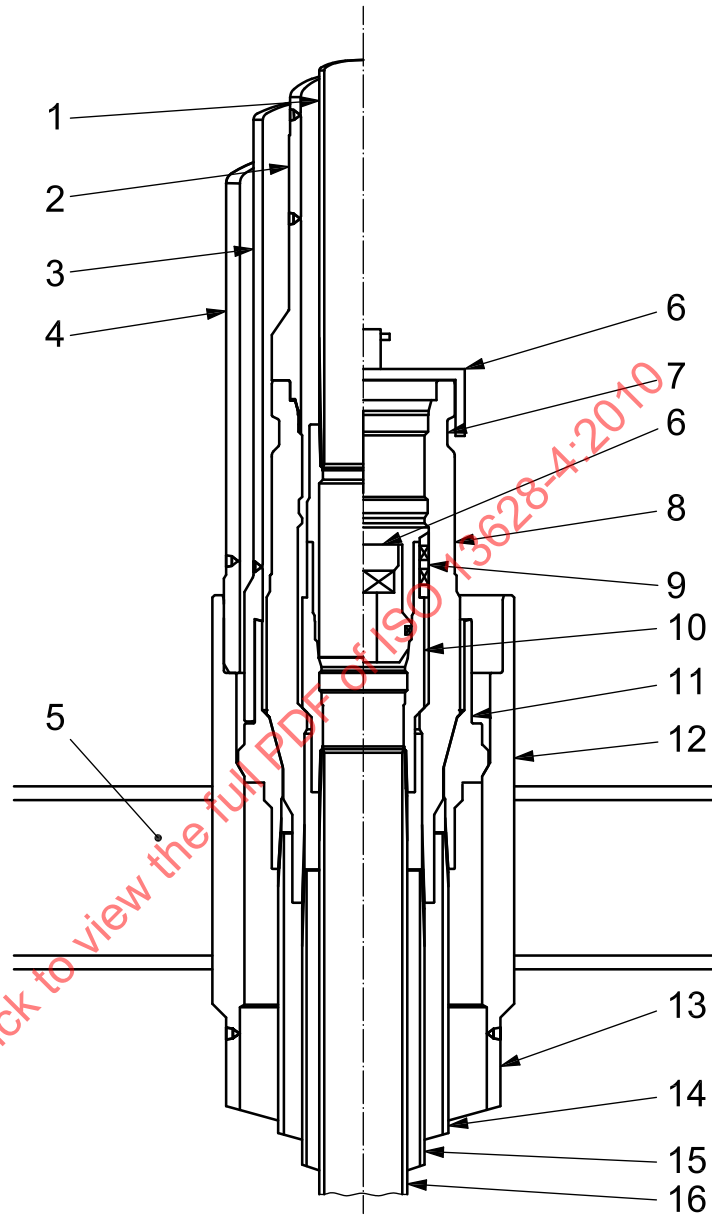

**Figure F.1 — Drill-through mudline suspension system**

## Annex G (informative)

### Assembly guidelines of ISO (API) bolted flanged connections

#### G.1 Scope

##### G.1.1 General

Successful use of ISO (API) bolted flanged connections require knowledge of their capabilities and careful assembly. This annex provides the provisions for assembly and bolt make-up for type 6BX integral, welding neck and blind flanges as defined in ISO 10423 and type 17SS integral, welding neck and blind flanges as defined in this part of ISO 13628.

##### G.1.2 Introduction

An assembly procedure and recommended make-up tension of bolting for bolted flanged connections is defined. Its purpose is to ensure structural integrity and control of leak-tightness for the ISO (API) bolted flanged connections.

##### G.1.3 Recommended bolting make-up tension/torque

Standard closure bolting shall be made up to a minimum between 67 % to 73 % of the minimum material yield strength to ensure gasket seating during make-up and increase face-to-face contact preload in excessive of separation forces at rated working pressure. Standard bolting materials, such as ASTM A193/A193M grades B7 and B16, and ASTM A320/320M grades L7 and L43, are defined as having a material yield strength of 725 MPa (105 000 psi) for diameters up to and including 63,5 mm (2,5 in). Larger-diameter bolts up to 177,8 mm (7 in) have a material yield strength of 655 MPa (95 000 psi). CRA bolting, such as ASTM A453/A453M class D (grade 660), has a material yield strength of 725 MPa (105 000 psi) for all sizes.

Low-strength closure bolting, such as ASTM A193/A193M grade B7M and ASTM A320/320M grade L7M, shall be made up to a minimum between 67 % to 73 % of the minimum specified yield strength to ensure gasket seating during make-up and to increase face-to-face contact preload in excessive of separation forces at rated working pressure. Low-strength bolting is defined as having a material yield strength of 550 MPa (80 000 psi).

Tables G.1 and G.3 provide torque values for ASTM A193/A193M grades B7 and B16, and ASTM A320/320M grades L7 and L43. Tables G.2 and G.4 provide torque values for ASTM A193/A193M grade B7M, and ASTM A320/320M grade L7M bolting material. These tables provide calculated torque values based on the material yield strengths listed in paragraphs 1 and 2 of this subclause and PTFE-coated bolts.

Some factors that affect the relationship between nut torque and bolt tension stress are the

- thread pitch, pitch diameter and thread form;
- surface finish of thread faces and nut bearing surface area;
- degree of parallelism of nut-bearing area with flange face;
- type of lubrication or coating of the threads (the friction factor associated with lubricants or coatings can vary up to 20 %), and nut-bearing surface area.

It should be recognized that torque applied to a nut is only one of several ways to approximate tension and stress in a fastener. The main requirement is to reach the applied tension stress range listed in this subclause and to achieve gasket seating and hub face-to-face make-up. Lubricants, surface finishes, gasket hardness, etc., may greatly influence the accuracy of actual bolt tension by applying torque. Therefore, the torque values listed in Tables G.1 to G.4 are provided only as an informative guide, and should be verified by the manufacturer using qualified bolting procedures.

**Table G.1 — Recommended flange-bolt torque (API grease)**

Bolt size <sup>a</sup>		L7, L43, B16, B7 or gr660 material							
		Make-up at 67 % of yield strength				Make-up at 73 % of yield strength			
		Bolt tension		Make up torque		Bolt tension		Make up torque	
mm	in, TIP	kN	(lbf)	N·m	(ft lbs)	kN	(lbf)	N·m	(ft lbs)
12,70	1/2; 13 UNC	44,17	(9 983)	108	(80)	48,38	(10 880)	118	(87)
15,88	5/8; 11 UNC	70,72	(15 900)	210	(155)	77,06	(17 320)	229	(169)
19,05	3/4; 10 UNC	104,66	(23 530)	366	(270)	114,04	(25 630)	398	(294)
22,23	7/8; 9 UNC	144,49	(32 480)	582	(430)	157,43	(35 395)	634	(467)
25,40	1; 8 UN	189,56	(42 615)	866	(639)	206,53	(46 430)	944	(696)
28,58	1 1/8; 8 UN	247,36	(55 610)	1 252	(924)	269,51	(60 590)	1 365	(1 006)
31,75	1 1/4; 8 UN	312,84	(70 330)	1 739	(1 283)	340,86	(76 630)	1 895	(1 398)
34,93	1 3/8; 8 UN	386,00	(86 777)	2 337	(1 724)	420,57	(94 548)	2 547	(1 878)
38,10	1 1/2; 8 UN	466,84	(104 950)	3 059	(2 256)	508,65	(114 349)	3 332	(2 458)
41,28	1 5/8; 8 UN	555,37	(124 852)	3 914	(2 887)	605,11	(136 032)	4 264	(3 145)
44,45	1 3/4; 8 UN	651,57	(146 480)	4 915	(3 625)	709,93	(159 560)	5 355	(3 950)
47,63	1 7/8; 8 UN	755,46	(169 833)	6 074	(4 480)	823,11	(185 044)	6 618	(4 880)
50,80	2; 8 UN	867,02	(194 914)	7 401	(5 460)	944,66	(212 370)	8 063	(5 947)
57,15	2 1/4; 8 UN	1 113,19	(250 256)	10 607	(7 823)	1 212,88	(272 665)	11 557	(8 524)
63,50	2 1/2; 8 UN	1 390,09	(312 504)	14 625	(10 787)	1 514,57	(340 490)	15 935	(11 753)
66,68	2 5/8; 8 UN <sup>b</sup>	1 393,38	(313 245)	15 351	(11 322)	1 518,16	(341 297)	16 725	(12 337)
69,85	2 3/4; 8 UN <sup>b</sup>	1 536,02	(345 310)	17 684	(13 043)	1 673,57	(376 234)	19 268	(14 211)

<sup>a</sup> Metric equivalents for bolt tension and make up torque are listed for convenience, even though inch-size bolts are recommended for use with this part of ISO 13628.

<sup>b</sup> Calculated based on reduced yield strength of 655 MPa (95 000 psi).

Table G.2 — Recommended flange bolt torque (API grease)

Bolt size		L7M or B7M material							
		Make-up at 67 % of yield strength				Make-up at 73 % of yield strength			
		Bolt tension		Make up torque		Bolt tension		Make up torque	
mm	in, TIP	kN	(lbf)	N·m	(ft lbs)	kN	(lbf)	N·m	(ft lbs)
12,70	1/2, 13UNC	33,83	(7 606)	82	(61)	36,86	(8 287)	89	(67)
15,88	5/8, 11UNC	53,88	(12 114)	160	(118)	58,71	(13 199)	174	(129)
19,05	3/4, 10UNC	79,74	(17 927)	279	(206)	86,88	(19 533)	304	(225)
22,23	7/8, 9 UNC	110,09	(24 750)	443	(327)	119,95	(26 967)	483	(356)
25,40	1, 8 UN	144,42	(32 468)	660	(487)	157,35	(35 376)	719	(531)
28,58	1 1/8, 8 UN	188,46	(42 368)	954	(704)	205,34	(46 162)	1 039	(767)
31,75	1 1/4, 8 UN	238,35	(53 584)	1 325	(977)	259,70	(58 383)	1 444	(1 065)
34,93	1 3/8, 8 UN	294,10	(66 116)	1 781	(1 314)	320,44	(72 037)	1 941	(1 432)
38,10	1 1/2, 8 UN	355,69	(79 963)	2 330	(1 719)	387,54	(87 124)	2 539	(1 873)
41,28	1 5/8, 8 UN	423,14	(95 125)	2 982	(2 200)	461,03	(103 644)	3 249	(2 397)
44,45	1 3/4, 8 UN	496,44	(111 603)	3 745	(2 762)	540,90	(121 597)	4 080	(3 009)
47,63	1 7/8, 8 UN	575,59	(129 397)	4 628	(3 413)	627,14	(140 985)	5 043	(3 719)
50,80	2, 8 UN	660,59	(148 506)	5 639	(4 159)	719,75	(161 805)	6 144	(4 532)
57,15	2 1/4, 8 UN	848,15	(190 671)	8 081	(5 961)	924,10	(207 746)	8 805	(6 495)
63,50	2 1/2, 8 UN	1 059,11	(238 098)	11 143	(8 218)	1 153,96	(259 420)	12 141	(8 954)
66,68	2 5/8, 8 UN <sup>b</sup>	1 173,37	(263 785)	12 927	(9 534)	1 278,45	(287 408)	14 085	(10 388)
69,85	2 3/4, 8 UN <sup>b</sup>	1 293,49	(290 787)	14 892	(10 984)	1 409,32	(316 828)	16 226	(11 968)

**Table G.3 — Recommended flange bolt torque (PTFE filler-based coating)**

Bolt size		L7, L43, B16, B7 or gr660 material							
		Make-up at 67 % yield strength				Make-up at 73 % yield strength			
		Bolt tension		Make up torque		Bolt tension		Make up torque	
mm	in, TPI	kN	(lbf)	N·m	(ft lbs)	kN	(lbf)	N·m	(ft lbs)
12,70	1/2, 13 UNC	44,40	(9 983)	64	(48)	48,38	(10 877)	70	(52)
15,88	5/8, 11 UNC	70,72	(15 900)	125	(92)	77,06	(17 322)	137	(100)
19,05	3/4, 10 UNC	104,66	(23 530)	216	(160)	114,04	(25 637)	236	(174)
22,23	7/8, 9 UNC	144,49	(32 483)	343	(253)	157,43	(35 391)	373	(275)
25,40	1, 8 UN	189,56	(42 614)	510	(376)	206,53	(46 430)	556	(409)
28,58	1 1/8, 8 UN	247,36	(55 608)	731	(539)	269,51	(60 588)	797	(588)
31,75	1 1/4, 8 UN	312,84	(70 330)	1 009	(744)	340,88	(76 627)	1 099	(810)
34,93	1 3/8, 8 UN	386,00	(86 777)	1 348	(994)	420,57	(94 548)	1 468	(1 083)
38,10	1 1/2, 8 UN	466,84	(104 951)	1 754	(1 294)	508,65	(114 349)	1 912	(1 410)
41,28	1 5/8, 8 UN	555,37	(124 852)	2 235	(1 649)	605,11	(136 032)	2 436	(1 797)
44,45	1 3/4, 8 UN	651,57	(146 480)	2 797	(2 063)	709,93	(159 597)	3 047	(2 247)
47,63	1 7/8, 8 UN	755,46	(169 833)	3 445	(2 541)	823,11	(185 042)	3 753	(2 768)
50,80	2, 8 UN	867,02	(194 914)	4 185	(3 087)	944,66	(212 370)	4 559	(3 363)
57,15	2 1/4, 8 UN	1 113,19	(250 256)	5 968	(4 402)	1 212,88	(272 667)	6 502	(4 796)
63,50	2 1/2, 8 UN	1 390,09	(312 504)	8 195	(6 044)	1 514,57	(340 490)	8 929	(6 586)
66,68	2 5/8, 8 UN <sup>a</sup>	1 393,38	(313 245)	8 587	(6 333)	1 518,16	(341 297)	9 356	(6 901)
69,85	2 3/4, 8 UN <sup>a</sup>	1 536,02	(345 310)	9 876	(7 284)	1 673,57	(376 234)	10 760	(7 937)

<sup>a</sup> Calculated based on reduced yield strength of 655 MPa (95 000 psi).

Table G.4 — Recommended flange bolt torque (PTFE filler-based coating)

Bolt size		L7M or B7M material							
		Make-up at 67 % of yield strength				Make-up at 73 % of yield strength			
		Bolt tension		Make up torque		Bolt tension		Make up torque	
mm	in, TPI	kN	(lbf)	N·m	(ft lbs)	kN	(lbf)	N·m	(ft lbs)
12,70	1/2, 13 UNC	33,83	(7 606)	49	(36)	36,86	(8 287)	54	(39)
15,88	5/8, 11 UNC	53,88	(12 114)	95	(70)	58,71	(13 199)	104	(76)
19,05	3/4, 10 UNC	79,74	(17 927)	165	(122)	86,88	(19 532)	180	(133)
22,23	7/8, 9 UNC	110,09	(24 750)	261	(193)	119,95	(26 966)	284	(210)
25,40	1, 8 UN	144,42	(32 468)	388	(287)	157,35	(35 376)	423	(312)
28,58	1 1/8, 8 UN	188,46	(42 368)	557	(411)	205,34	(46 162)	607	(448)
31,75	1 1/4, 8 UN	238,35	(53 584)	768	(567)	259,70	(58 383)	837	(617)
34,93	1 3/8, 8 UN	294,10	(66 116)	1 027	(757)	320,44	(72 036)	1 119	(825)
38,10	1 1/2, 8 UN	355,69	(79 963)	1 337	(986)	387,54	(87 124)	1 457	(1 074)
41,28	1 5/8, 8 UN	423,14	(95 125)	1 703	(1 256)	461,03	(103 644)	1 856	(1 369)
44,45	1 3/4, 8 UN	496,44	(111 603)	2 131	(1 572)	540,90	(121 597)	2 322	(1 713)
47,63	1 7/8, 8 UN	575,59	(129 397)	2 642	(1 936)	627,14	(140 985)	2 879	(2 109)
50,80	2, 8 UN	660,59	(148 506)	3 188	(2 352)	719,75	(161 805)	3 474	(2 563)
57,15	2 1/4, 8 UN	848,15	(190 671)	4 547	(3 354)	924,10	(207 746)	4 954	(3 654)
63,50	2 1/2, 8 UN	1 059,11	(238 098)	6 244	(4 605)	1 153,96	(259 420)	6 803	(5 017)
66,68	2 5/8, 8 UN <sup>b</sup>	1 173,37	(263 785)	7 231	(5 333)	1 278,45	(287 408)	7 879	(5 811)
69,85	2 3/4, 8 UN <sup>b</sup>	1 293,49	(290 787)	8 317	(6 134)	1 409,32	(316 828)	9 062	(6 683)

The values in Tables G.1 through G.4 are calculated as given in a) through c).

- a) Hexagon size (heavy hex nuts) equals  $1,5D + 3,175$  mm ( $1,5D + 0,125$  in), where  $D$  is the bolt diameter, expressed in millimetres (inches).
- b) The flange bolt torque,  $T$ , expressed in SI units of newton-metres, is given by Equation (G.1):

$$T = \frac{F(P) \left[ \left( \frac{1}{N} \right) + \pi(f)(P)(\sec 30^\circ) \right]}{2 \times 10^2 \left[ \pi(P) - (f) \left( \frac{1}{N} \right) (\sec 30^\circ) \right]} + \frac{h + D + 3,175(F)(f)}{4 \times 10^2} \quad (\text{G.1})$$

where

$D$  is the bolt diameter, expressed in millimetres;

$A_s$  is the effective stress area, expressed in square millimetres, equal to  $\left( \frac{\pi}{4} \right) \left[ D - \left( \frac{0,9743}{N} \right) \right]^2$ ;

$F$  is the bolt tension, expressed in newtons, equal to  $A_s$  times the bolt stress;

$N$  is the number of threads per millimetre;

$P$  is the pitch diameter, expressed in millimetres;

$f$  is the friction factor;

$h$  is the hexagon size, expressed in millimetres.

c) The flange bolt torque,  $T$ , expressed in imperial units of foot-pounds, is given by Equation (G.2):

$$T = \frac{F(P) \left[ \left( \frac{1}{N} \right) + \pi(f)(P)(\secant 30^\circ) \right]}{2(12) \left[ \pi(P) - (F) \left( \frac{1}{N} \right) (\secant 30^\circ) \right]} + \frac{h + D + 0,125(F)(f)}{4(12)} \quad (\text{G.2})$$

where

$D$  is the bolt diameter, expressed in inches;

$A_s$  is the effective stress area, equal to  $\left( \frac{\pi}{4} \right) \left[ D - \left( \frac{0,9743}{N} \right) \right]^2$ ;

$F$  is the force or bolt tension, expressed in pounds, equal to  $A_s$  times the bolt stress;

$N$  is the number of threads per inch;

$P$  is the pitch diameter of thread, expressed in inches;

$f$  is the friction factor (equal to 0,13 with threads and nut-bearing area well lubricated with API Bul 5A2 thread compound; 0,07 for threads and nuts coated with a PTFE filler-based coating; 0,20 for "dry" uncoated/unlubricated threads and nuts) (dimensionless);

$h$  is the hexagon size, expressed in inches.

## G.2 Guidelines for assembly

### G.2.1 Introduction

Leak-free bolted flanged connections are the result of many selections/activities having been made/performed within a relatively narrow band of acceptable limits. One of these activities essential to leak-free performance is the connection assembly process. The provisions outlined in Annex G cover the assembly elements essential for consistent leak-tight performance of ISO (API) flanged connections. Written procedures, incorporating the features of these provisions shall be developed for use by the qualified connection assemblers. The applied torque/tension in the written procedures shall be qualified for some relevant bolt sizes with actual material, coating and lubrication.

NOTE 1 There are many ways to assemble an ISO (API) bolted flanged connection and Annex G is intended to provide provisions to those responsible for preparing bolted flanged connection assembly (make-up) procedures or for qualifying bolted flange connection assembler.

NOTE 2 The types of bolt-up tools and load control techniques covered by Annex G are not intended to exclude or limit other tools and techniques that are certified to produce an equivalent or better bolt preload scatter value.

NOTE 3 The use of qualified assembly procedures and qualified assemblers is analogous to the general requirements for welds, where use of qualified welding procedures and qualification of welders is present industry practice.



## G.2.2 Examination of “working” surfaces

All flange “working” surfaces should be cleaned and examined before assembly. A non-abrasive cloth may be used to clean all working surfaces to remove grease, preservation coatings and dirt. “Working” surfaces are intended to have metal-to-metal contact during make-up, hence any painting on a flange’s working surfaces should be removed. Adherent coatings, such as PTFE or plating, are acceptable on the flange working surfaces. Greases shall not be applied on gaskets or grooves during make-up. Light oils may be used if galling or fretting is a concern.

Examine the ring groove surfaces of both connection flanges for appropriate surface finish and for damage to surface finish, such as scratches, nicks, gouges and burrs. Indications running radially in the outer ring groove (leak path) are of particular concern. Unacceptable scratches and dents in the groove and flange face require re-machining. Correct any radial defect in the groove that exceeds the depth of serrations. The defects may be removed by lightly polishing with a fine abrasive “wet or dry” paper around the gasket seat circumference. Ensure that the rework area blends in uniformly and avoid local polishing of the defect. Report any questionable imperfections for appropriate disposition.

A new gasket shall be used whenever a flange is opened and re-made. Check the gasket contact surfaces of both surfaces for any mechanical damage and for surface roughness. Reject damaged or questionable gaskets. Gaskets may be reused for testing purpose. A new gasket shall always be used for final assembly. If required, light oil can be used to lubricate the gasket during seating. Take care that no solid particles are present in the lubricant. Report any questionable results.

Examine stud and nut threads for deformation and damage, such as rust, corrosion, cracks and burrs. Previously used bolts should be thoroughly cleaned (such as wire brushing) before being reused. Inspect studs that have been subjected to high-cycle external loading with an appropriate NDE technique. Replace questionable parts.

Examine nut-bearing surfaces of flanges for scores, burrs, galling marks etc.; remove protrusions, spot face if required.

## G.2.3 Alignment of mating surfaces

Ensure that flanges are aligned both axially and rotationally to the design plane within specified tolerances. Be sure that any pipe or other connection that affects the alignment is properly supported. The use of bolt load to achieve flange alignment is not permitted. There should be just sufficient gap to insert the gasket in case of horizontal assembly. The flange faces should be aligned within 0,5 mm per each 200 mm (0,02 in per each 7,875 in) measured across any diameter (0,15°), and flange bolt holes should be aligned within 3 mm (0,12 in) offset; see Figure G.1. Report any questionable misalignment or use of excessive loads to align the flanges.

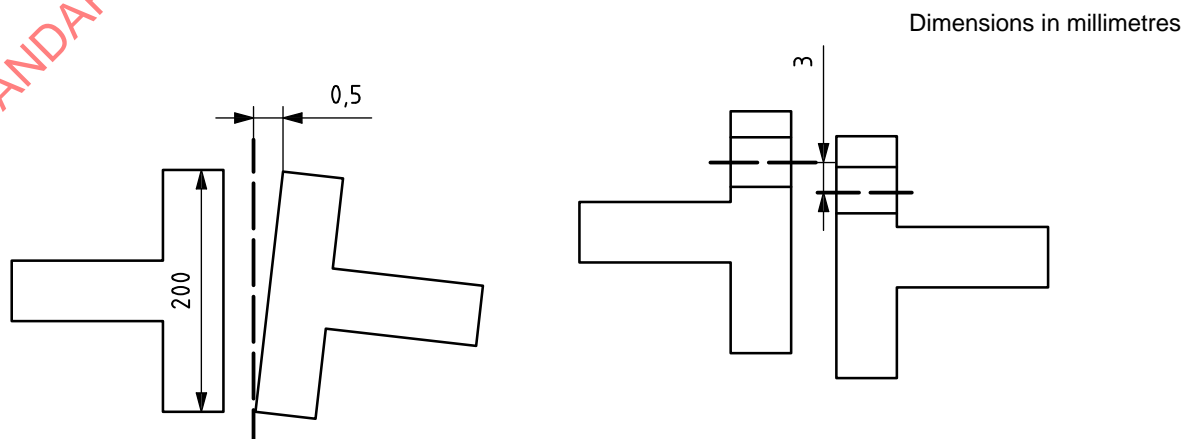

Figure G.1 — Flange-to-flange alignment tolerances

#### G.2.4 Installation of BX gaskets

Check that the BX/SBX gasket complies with specified ring number and material specification.

Position the gasket such that it is concentric with the groove, taking suitable measures to ensure that it is adequately supported during the positioning process.

Ensure that the gasket remains in place during the assembly process. Do not use grease to keep the gasket in position.

#### G.2.5 Installation of bolts

Verify compliance with bolt and nut specifications for the following: material grades, coating, diameter, length of bolts and nut thickness equal to the bolt diameter (heavy hex series nut).

The nut thread and nut-bearing surface should be lubricated in accordance to the qualified procedure when torque tools are used. Ensure that the lubricant is chemically compatible with the bolt/nut materials and the exposed environment. Particular care should be taken to avoid lubricant chemistry that can result in stress corrosion cracking.

Install bolts and nuts hand-tight, then manual torque to 100 N·m (75 ft-lbs) but not exceeding 15 % of target torque. If nuts do not hand-tighten, check for cause and make necessary corrections. If not, final target torque is applied immediately. It is recommended to take measures to temporarily seal off the flange faces to avoid foreign particle ingress into the gap between the flange-raised faces.

The nuts shall engage the threads for the full depth of the nut. Corrosion of excess thread can hinder joint disassembly. A practice that facilitates connection disassembly is to fully engage the nut on one end (with no part of the bolt projecting beyond the nut) so that all excess length is located on the opposite end. The excess threads should not project more than 13 mm (0,5 in) beyond the nut, unless required for use of hydraulic tensioners. Hydraulic bolt tensioners require excess thread length of about one bolt diameter for engagement of a pull adapter.

#### G.2.6 Tightening of the bolts

Calibrated tools shall be used. Use the selected tightening method, tighten the connection using load-increment rounds of 30 %, 60 %, then 100 % of the specified make-up torque value, in addition to using the crisscross tightening-sequence pattern as shown in Figure G.2. Do not tighten the connection while it is subject to pressure or mechanical loads.

Check that the flange-face gap at the raised face is closed all around the circumference of the connection.

Bolt tension (or torque) should be rechecked after a flange (or bolted clamp) has been subjected to the initial hydrostatic pressure tests (body test or rated working pressure test). In some instances, the bolting can undergo some minor yielding during the test. Retighten the bolts, as necessary, to 100 % of the make-up tension (torque) in a crisscross pattern.

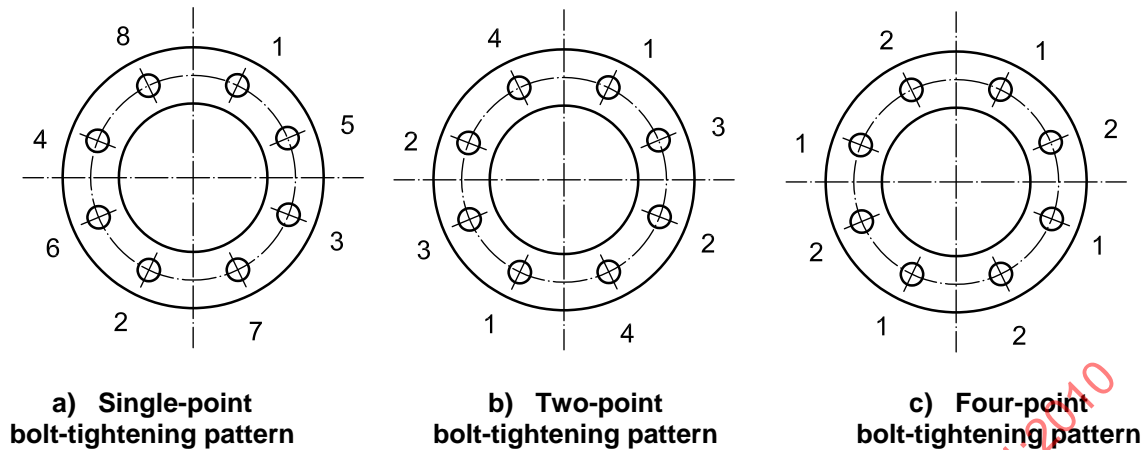

Figure G.2 — Cross-bolt torque tightening sequence for one tool, two tools and four tools

### G.2.7 Connection disassembly

When a significant number of bolts is loosened in rotational order, the elastic recovery of the clamped parts can result in excessive loads on the relatively few remaining bolts, making further disassembly difficult and sometimes causing galling between the nut and bolt, which can seriously affect safe disassembly.

Always check, never take for granted, that the connection has been de-pressurized. Ensure that there are no built-in loads in the connection due to restraints. Loosen bolts in the order of a crisscross pattern (see Figure G.2) as follows.

- Start with loosening the nuts to 60 % of the target torque in a cross pattern.
- Check the gap around the circumference and loosen nuts in the order required to accomplish a reasonably uniform gap.
- Loosen the nuts to 30 % of the target torque.
- If the gap around the circumference is reasonably uniform, proceed with nut removal on a rotational basis. If the gap around the circumference is not reasonably uniform, make the appropriate adjustments by selective loosening before proceeding with nut removal on a rotational basis.
- Remove bolts and nuts. Before bolts can be reused, they shall be cleaned and NDE examined. If gaskets are reused for testing purpose, marks should be placed on the gaskets to ensure that new gaskets are used for the final assembly.

### G.2.8 Records

Manufacturers shall document recommended make-up tension (or torque) as a part of the end connection assembly record for each assembled connection. A typical record is provided in Table G.5.

**Table G.5 — Flange connection make-up record**  
[\(Click here to access an electronic revisable version of this form.\)](#)

<b>BOLTED FLANGED CONNECTION MAKE-UP RECORD</b>					
Flange connection identification:					
<b>ASSEMBLY</b>					
Assembled by:			Date:		
<b>Clean and examination of components prior to assembly</b>					
Clean and check that ring groove and BX gasket seating surfaces are free for damages.		Clean bolts and nuts and check that they are free from damage.			
Clean and check that the nut bearing surface of flanges are free of paint, dirt and galling marks					
<b>Check applied flange connection components</b>					
Bolt material		Nut material			
Bolt diameter and length		Bolt/nut coating			
Gasket size and material		New BX gasket used for final assembly			
<b>Lubrication of bolt/nut "working surfaces"</b>					
Check that applied lubrication on bolt end threads/nut bearing surface corresponds with the lubrication used for establishing torque tables			Applied lubrication:		
<b>Alignment and installation of bolts</b>					
Studs free to move within in bolt holes		Yes No		Maximum flange face gap (mm)	
Hand tight torque (Nm)		Minimum flange face gap (mm)			
<b>TIGHTENING OF BOLTS</b>					
Target bolt load		Tool type:		Number of tools:	
30 % preload		60 % preload		100 % preload	
Torque	Pump pressure	Torque	Pump pressure	Torque	Pump pressure
Face-to-face contact		Torque by: _____ Date: _____			
<b>UNANTICIPATED PROBLEMS AND THEIR SOLUTIONS</b>					
<b>CONTROL</b>			By: _____ Date: _____		
Target preload:	Torque:	Tool:	Pump pressure:	Preload acceptable:	Flange face contact:

## Annex H (informative)

### Design and testing of subsea wellhead running, retrieving and testing tools

#### H.1 General

Annex H addresses the design and testing of tools for running, retrieving and testing all subsea wellhead components, including guidance equipment, housings, casing suspension equipment, annulus sealing equipment and protective devices.

#### H.2 Design

##### H.2.1 Loads

As a minimum, the following loads shall be considered when designing the running, retrieving and testing tools:

- suspended weight;
- bending loads;
- pressure;
- torsional loads;
- radial loads;
- overpull;
- environmental loads;
- hydraulic coupler thrust and/or preloads.

##### H.2.2 End connections

Tool joints or casing threads shall be in accordance with ISO 10424-1. Casing threads shall be in accordance with ISO 10423. The tool shall have an adequate dimension for tonging. The load capacity of the tool shall not be inferred from the choice of end connections for the tool.

Torque-operated tools shall preferably use left-hand torque for make-up and right-hand torque for release, to prevent backoff of casing/tubing/drill pipe threads during operation/disconnection.

##### H.2.3 Vertical bore

Tools with through-bore shall have a sufficient ID and internal transitions to allow the passage of tools required for subsequent operations in accordance with the manufacturer's written specification.

## H.2.4 Outside profile

The outside profile of the tools shall be in accordance with the manufacturer's written specification. The length, outside profile and fluid-bypass area shall be designed to minimize surge/swab pressure and for ease of running while tripping and circulating.

## H.2.5 Load capacity

Tool load ratings shall be in accordance with the manufacturer's written specification.

## H.2.6 Vent

The conductor-housing running tool shall be provided with a vent or system of vents. This system of vents is used either to fill the conductor with fluid during running or to allow the passage of cuttings during a jetting operation.

## H.2.7 Pressure rating

The pressure and depth rating of the tool shall be in accordance with the manufacturer's written specification.

## H.3 Materials

### H.3.1 Selection

The materials used in these tools shall be chosen for strength and it is not necessary that they be resistant to corrosive environments. They shall comply with the manufacturer's written specification.

NOTE If exposure to severe stress cracking environments is expected, special practices beyond the scope of this part of ISO 13628 can be required.

### H.3.2 Coatings

Coatings shall conform to 5.1.4.7.

## H.4 Testing

### H.4.1 Validation testing

Validation testing shall conform to 5.1.7.

### H.4.2 Factory acceptance testing

All tools shall be functionally tested, dimensionally inspected or gauged to verify their correct operation prior to shipment from the manufacturer's facility. Tools with hydraulic operating systems shall have the hydraulic system tested in accordance with the manufacturer's written specification. This hydrostatic test shall consist of three parts:

- primary pressure-holding period;
- reduction of the pressure to zero (atmospheric);
- secondary pressure-holding period.