

INTERNATIONAL STANDARD

ISO
21898

First edition
2004-07-01

Packaging — Flexible intermediate bulk containers (FIBCs) for non-dangerous goods

*Emballages — Grands récipients vrac souples (GRVS) pour matières
non dangereuses*

STANDARDSISO.COM : Click to view the full PDF of ISO 21898:2004



Reference number
ISO 21898:2004(E)

© ISO 2004

PDF disclaimer

This PDF file may contain embedded typefaces. In accordance with Adobe's licensing policy, this file may be printed or viewed but shall not be edited unless the typefaces which are embedded are licensed to and installed on the computer performing the editing. In downloading this file, parties accept therein the responsibility of not infringing Adobe's licensing policy. The ISO Central Secretariat accepts no liability in this area.

Adobe is a trademark of Adobe Systems Incorporated.

Details of the software products used to create this PDF file can be found in the General Info relative to the file; the PDF-creation parameters were optimized for printing. Every care has been taken to ensure that the file is suitable for use by ISO member bodies. In the unlikely event that a problem relating to it is found, please inform the Central Secretariat at the address given below.

STANDARDSISO.COM : Click to view the full PDF of ISO 21898:2004

© ISO 2004

All rights reserved. Unless otherwise specified, no part of this publication may be reproduced or utilized in any form or by any means, electronic or mechanical, including photocopying and microfilm, without permission in writing from either ISO at the address below or ISO's member body in the country of the requester.

ISO copyright office
Case postale 56 • CH-1211 Geneva 20
Tel. + 41 22 749 01 11
Fax + 41 22 749 09 47
E-mail copyright@iso.org
Web www.iso.org

Published in Switzerland

Contents

Page

Foreword	iv
1 Scope	1
2 Normative references	1
3 Terms and definitions	1
4 Materials, construction and design	4
4.1 Materials	4
4.2 Construction	5
4.3 Design filling height	5
5 Performance	5
5.1 Type-testing	5
5.2 Preparation of FIBC for test	5
5.3 Test requirements	6
6 Certification	6
7 Marking	7
Annex A (normative) UV resistance test	9
Annex B (normative) Cyclic top lift test	10
Annex C (normative) Compression/stacking test	18
Annex D (informative) Guidance on selection and use of FIBCs	19
Annex E (informative) Design of FIBCs	24
Bibliography	28

Foreword

ISO (the International Organization for Standardization) is a worldwide federation of national standards bodies (ISO member bodies). The work of preparing International Standards is normally carried out through ISO technical committees. Each member body interested in a subject for which a technical committee has been established has the right to be represented on that committee. International organizations, governmental and non-governmental, in liaison with ISO, also take part in the work. ISO collaborates closely with the International Electrotechnical Commission (IEC) on all matters of electrotechnical standardization.

International Standards are drafted in accordance with the rules given in the ISO/IEC Directives, Part 2.

The main task of technical committees is to prepare International Standards. Draft International Standards adopted by the technical committees are circulated to the member bodies for voting. Publication as an International Standard requires approval by at least 75 % of the member bodies casting a vote.

Attention is drawn to the possibility that some of the elements of this document may be the subject of patent rights. ISO shall not be held responsible for identifying any or all such patent rights.

ISO 21898 was prepared by Technical Committee ISO/TC 122, *Packaging*, Subcommittee SC 3, *Performance requirements and tests for means of packaging, packages and unit loads*.

STANDARDSISO.COM : Click to view the full PDF of ISO 21898:2004

Packaging — Flexible intermediate bulk containers (FIBCs) for non-dangerous goods

1 Scope

This International Standard specifies materials, construction and design requirements, type test, certification and marking requirements for flexible intermediate bulk containers (FIBCs) intended to contain non-dangerous solid materials in powder, granular or paste form, and designed to be lifted from above by integral or detachable devices.

Guidance is also provided on the selection and safe usage of FIBCs.

2 Normative references

The following referenced documents are indispensable for the application of this document. For dated references, only the edition cited applies. For undated references, the latest edition of the referenced document (including any amendments) applies.

ISO 12048, *Packaging — Complete, filled transport packages — Compression and stacking tests using a compression tester*

ISO 13934-1, *Textiles — Tensile properties of fabrics — Part 1: Determination of maximum force and elongation at maximum force using the strip method*

ISO/IEC 17025, *General requirements for the competence of testing and calibration laboratories*

3 Terms and definitions

For the purposes of this document, the following terms and definitions apply.

3.1 General

3.1.1

flexible intermediate bulk container FIBC

intermediate bulk container having the body made of flexible material such as woven fabric, plastics film or paper, designed to be in contact with the contents, either directly or through an inner liner, and collapsible when empty

3.1.2

heavy-duty reusable flexible intermediate bulk container

FIBC designed and intended to be used for a multitude of fillings and discharges, and both factory and field repairable in such a way that the tensile strength across a repair is at least as great as that of the original

3.1.3

standard-duty reusable flexible intermediate bulk container

FIBC designed and intended to be used for a limited number of fillings and discharges

NOTE 1 An FIBC of this category cannot be reused if damaged, i.e. it is not repairable.

NOTE 2 The replacement of a removable inner liner is not considered a repair.

3.1.4

single-trip flexible intermediate bulk container

FIBC designed and intended to be used for one filling only

NOTE An FIBC of this category cannot be reused. Neither replacement of an inner liner nor repair of the FIBC is relevant to this category.

3.1.5

FIBC type

FIBCs of like design, manufactured using like materials and methods of construction (giving at least equal performance) to the same nominal cross-sectional dimensions

NOTE 1 Within a type, the circumference may be increased by up to 10 % by comparison with samples passing a type test, provided the same geometry is maintained. Where the type has a base discharge spout, smaller diameter discharge spouts of like design may be used.

NOTE 2 The presence or absence of an inner liner does not constitute a change of type.

3.1.6

safe working load

SWL

maximum load which the FIBC may carry in service, as certified

3.1.7

safety factor

SF

integer quotient between the final test load in the cyclic top lift test and the SWL value rounded down

NOTE 1 Safety factors may be illustrated as follows (see also B.3.3):

	Example 1	Example 2
Designated SWL	500 kg	500 kg
Final load, cyclic test	2 400 kgf	2 600 kgf
Quotient	4,8	5,2
Integer quotient, rounded down	4	5

NOTE 2 The results in Example 1 above indicate a single-trip FIBC which does not meet the requirements of this International Standard, whilst those in Example 2 indicate a single-trip FIBC which meets the requirements.

3.1.8

lifting device

integral and/or fixed lifting devices which form part of the FIBC and are tested with it

NOTE Detachable lifting devices are regarded as lifting tools.

3.2 FIBC parts

3.2.1

walls

tube of one or more layers, seamless or made out of one or more panels joined together

3.2.2

base

that part of the FIBC which is connected to or integral with the walls and forms the base of the standing FIBC

3.2.3

plain base

base without an opening

3.2.4**base with opening**

flat, conical or in another way formed base with an opening

3.2.5**full open base**

extensions to the wall(s), forming the base of the FIBC after closing

3.2.6**top**

upper part of the FIBC, excluding handling devices, forming the top of the FIBC after closing

3.2.7**body**

walls and base of the FIBC

3.2.8**inner liner**

integral or removable container which fits into the FIBC

3.3 Operating devices**3.3.1****filling opening**

opening for filling the FIBC

3.3.2**filling spout**

tube-shaped part at the top for filling the FIBC

3.3.3**filling slit**

slit-shaped opening at the top for filling the FIBC

3.3.4**outlet**

opening for discharging the FIBC

3.3.5**discharging spout**

tube-shaped part at the base for discharging the FIBC

3.3.6**closing parts**

webbing, cords, straps, etc. which are used to close the filling and discharging devices

3.4 Handling devices**3.4.1****supporting and lifting devices**

webbings, loops, ropes, eyes, frames or other devices formed from a continuation of the walls of the FIBC, which are integral or detachable, and are used to support or lift the FIBC

3.4.2**four-point lifting**

four lifting devices used simultaneously to lift the FIBC

3.4.3

two-point lifting

two lifting devices used simultaneously to lift the FIBC

3.4.4

one-point lifting

one lifting device, or one or more lifting devices brought to one point for lifting

3.5

safety and protection devices

valves, ventilation devices and additional parts which protect the filling, discharging or handling devices

3.6

coated and laminated materials

materials having a surface coating or comprising two or more layers laminated together to protect the contents of the filled FIBC or to protect the environment against the effects of leakage of the contents

3.7 Special treatments

3.7.1

stabilization

modification of the FIBC materials to give better resistance against weathering and ageing

EXAMPLE

The addition of an ultraviolet (UV) absorber and/or an antioxidant.

3.7.2

electrostatic conductivity treatment

treatment for modifying the electrostatic behaviour of the FIBC

3.7.3

insect-repellent treatment

treatment for increasing the ability of the FIBC to protect itself and/or its contents against insect attack

3.7.4

flame-retardant treatment

treatment to impart flame resistance to the FIBC

4 Materials, construction and design

4.1 Materials

All categories of FIBC shall be manufactured from flexible materials covered by a written specification. The FIBC manufacturer shall have an authorized statement of conformity for each separate batch of materials.

The properties of the materials may be modified by additives to improve the resistance of the materials against, for example, degradation by heat and sunlight, and to reduce the effect of static electricity.

All materials shall be tested for breaking force in accordance with the appropriate International Standards, and shall be capable of retaining at least 85 % of the original breaking force after being completely immersed in water for (25 ± 1) h. This measurement shall be taken after first drying the test specimen then, secondly, by conditioning it for (60 ± 5) min at a temperature of (23 ± 2) °C and a relative humidity of (50 ± 5) %.

All load-bearing materials of the FIBC shall, after being tested in accordance with the test described in Annex A, retain at least 50 % of the original values of the breaking force and elongation of the materials.

Materials should be chosen and joined together in such a way that recovery is promoted.

4.2 Construction

All stitched seams and joints shall be locked off and/or back sewn, or provided with a minimum 20 mm tail. All stitched seam-ends shall be secured. The surfaces to be joined by welding, glueing or heat-sealing shall be clean.

4.3 Design filling height

The designed filling height of the FIBC shall be between 0,5 and 2 times the shortest horizontal dimension of the FIBC.

NOTE For FIBCs with a circular cross-section, the shortest horizontal dimension is normally the diameter of the FIBC base. For FIBCs with a rectangular base, the shortest horizontal dimension is normally the shortest side.

5 Performance

5.1 Type-testing

All FIBC types shall be subjected to the following tests:

- a) cyclic top lift;
- b) compression/stacking test.

At least three specimens of each FIBC type shall be submitted for testing leading to certification. The specimens shall be tested as follows.

- Specimen 1: cyclic top lift test using the FIBC having the shortest vertical dimension.
- Specimen 2: cyclic top lift test using the FIBC having the greatest vertical dimension.
- Specimen 3: compression test using the FIBC having the greatest vertical dimension.

To comply with this International Standard the three specimens shall all withstand the tests.

When the FIBC type has only one fixed vertical dimension, only Specimens 1 and 3 need be submitted and tested to withstand the tests.

One tested sample shall be durably identified and retained for reference in any later complaint or arbitration.

Tests shall be carried out at a testing facility capable of meeting the operational provisions of ISO/IEC 17025.

5.2 Preparation of FIBC for test

5.2.1 Filling

For both the top lift and compression/stacking test, the FIBC shall be filled to the level specified in accordance with 4.3 by the manufacturer/supplier with a tolerance of $+5\%$ of that height. The FIBC shall be filled with either

- a) a material, e.g. plastics granules, having the following mechanical properties:
 - bulk density, 500 kg/m³ to 900 kg/m³,
 - mesh size 3 mm to 12 mm,
 - angle of repose 30° to 35°, or
- b) the actual contents to be carried, when these are known, and where their use will not itself be a hazard

NOTE When option b) is chosen, the FIBC type is certified in relation to that specific product only.

5.2.2 Conditioning

The filled FIBC shall be conditioned before testing at ambient temperature and relative humidity. However, in the event of dispute, testing shall be carried out after conditioning under standard conditions of $(23 \pm 2) ^\circ\text{C}$ and $(50 \pm 5) \%$ relative humidity.

5.3 Test requirements

5.3.1 Cyclic top lift test(s)

Cyclic top lift test(s) shall be carried out in accordance with Annex B and the following criteria shall apply:

- a) there shall be no breakage of any lifting devices to the extent that any of the lifting devices ceases to support its load; and
- b) when tested with an inner liner, there shall be no protrusion of the latter beyond the outer surface of the FIBC, except through the closure(s), where this is a design feature; and
- c) there shall be no loss of contents; and
- d) no deterioration of the body which renders the FIBC unsafe for transport or storage.

A slight discharge during the test (e.g. from closures or stitch holes) should not be considered to be a failure of the FIBC, provided that no further leakage occurs after the FIBC has been raised clear of the ground.

5.3.2 Compression/stacking test

The compression/stack test shall be carried out in accordance with Annex C and the following criteria shall apply:

- a) there shall be no loss of contents; and
- b) no deterioration of the body which renders the FIBC unsafe for transport or storage.

A slight discharge during the test (e.g. from closures or stitch holes) should not be considered to be a failure of the FIBC, provided that no further leakage occurs after the FIBC has been raised clear of the ground.

6 Certification

It is recommended that an FIBC type which conforms to the requirements of this International Standard should be certified by a body working under appropriate operational provisions (such as those given in ISO/IEC Guide 65) with a certificate of conformity based on a successful test report(s). ISO/IEC Guide 65 may often be used but it is not a requirement of this International Standard that it shall be used. Where, however, testing and certification are carried out by the same organization, separate individuals shall be responsible for the tests and for the certification based on them, and shall be clearly identified in the documentation.

The certificate shall contain the data shown for the marking specified in Clause 7a) to i) and Clause 7k) to m), together with

- a) the name(s) and address(es) of the certifying body and of the test station(s), together with the reference(s) and date(s) of the relevant test report(s), and
- b) the material used as contents in the cyclic top lift and compression/stacking tests.

A certificate for an FIBC type shall be valid for a period of three years from the date of issue.

An FIBC certified and marked as a single-trip FIBC in conformity with this International Standard shall not be reused.

An FIBC certified and marked as a reusable (heavy- or standard-duty) FIBC in conformity with this International Standard shall be reused only with the same type of contents as in the first use.

Reuse of FIBCs with contents differing from those of the first use is not in accordance with this International Standard.

7 Marking

All FIBCs shall be durably marked by means of a permanently attached and easily visible and readable label, or durably printed on the body so that it is easily visible and read after the FIBC has been filled. The following data shall be included:

- a) name and address of the manufacturer;
- b) manufacturer's reference, which shall be unique to any one FIBC type;
- c) name and address of the supplier, if required;
- d) safe working load (SWL) in kilograms;
- e) safety factor (SF), i.e. 5:1, 6:1 or 8:1 as appropriate;
- f) reference to this International Standard;
- g) class of FIBC, i.e. "heavy-duty reusable", "standard-duty reusable" or "single-trip";
- h) type test certificate number (which shall be unique to any one type) and the month and year in which the type test certificate was issued;
- i) name of the approved laboratory;
- j) date of manufacture of the FIBC, i.e. month and year;
- k) pictograms of the recommended handling methods;
- l) details of any special treatments as defined in 3.7;
- m) where the FIBC is certified in relation to a specific product, the description of that product shall be added.

The layout of the label shall be as in Figure 1.

MANUFACTURER'S NAME & ADDRESS:	
MANUFACTURER'S REFERENCE:	
S.W.L.: _____ kg SAFETY FACTOR: _____ :1	
	TEST CERTIFICATE No:
	TEST CERTIFICATE Date:
	APPROVED LABORATORY:
	TEST STANDARD: ISO 21898:2004
	FIBC CLASS:
	DATE OF MANUFACTURE OF FIBC:
	SPECIFIC TREATMENTS (if required):
	CERTIFIED ONLY FOR (if required):
Handling recommendations/Pictograms:	
Suppliers name and address (if required):	

Figure 1 — FIBC label

Annex A (normative)

UV resistance test

A.1 General

Materials often undergo rapid photochemical degradation under the influence of sunlight, unless they have been stabilized in a durable fashion. An accelerated ageing that simulates ageing caused by sunlight may be brought about by irradiation with light of a UV type. Samples cut from the load-bearing materials of the FIBC (e.g. fabric, webbing, rope, sewing thread, glues) are subjected for a certain period of time to irradiation from a light source of the UV type with specified spectral distribution. A number of factors of uncertainty are inherent in the procedure, so comparisons should be available between the method used and exposures in the environment in which the product is to be used.

Certain types of UV stabilizing additives are rapidly leached out, especially in an alkaline environment. This should be taken into consideration in applicable situations.

The performance of UV stabilizing additives may be affected by colour and the type of pigment used. Therefore, each combination of UV stabilizing additive and pigment should be tested separately.

A.2 Principle

Test specimens are alternately exposed to UV light alone and to condensation alone in a repetitive cycle.

A.3 Apparatus

The apparatus should be in accordance with ASTM G154-98, using a UV-B lamp.

A.4 Procedure

Expose a test specimen to a fluorescent UV lamp for at least 200 h, using a test cycle of 8 h at 60 °C with UV radiation, alternating with 4 h at 50 °C with condensation.

After exposure is complete, test the specimen for breaking force and elongation at break in accordance with ISO 13934-1 using the conditioning requirements given in 5.2.2. Compare the values with results performed on simultaneously cut test specimens that have been stored under dark and cool conditions.

A.5 Expression of results

Express the results for breaking force in newtons on test specimens tested before and after exposure to the UV radiation.

Annex B (normative)

Cyclic top lift test

B.1 Principle

The filled FIBC is suspended by its lifting devices with a flat pressure plate positioned on top of the contents. This is done in one of two alternative ways:

- a) the pressure plate is restrained either from above or below; the FIBC is suspended from a frame to which an upward force is applied progressively against the resistance of the pressure plate; or
- b) the FIBC is suspended from a frame fixed at the time of test, then a downward force is applied progressively to the pressure plate.

The filled FIBC is subjected to a repeated loading, unloading and dwell cycle. The force is recorded and the FIBC is observed for breakage of any lifting device, other damage or leakage of contents.

B.2 Requirements for apparatus

B.2.1 General

B.2.1.1 The pressure plate shall be flat except that flanges may be fitted to its underside to prevent lateral displacement. The plate shall be of such a size that it covers between 60 % and 80 % of the surface area of the contents.

B.2.1.2 The suspension frame shall be such that, during the test, the filled FIBC can be suspended clear of the ground with its lifting devices positioned as recommended by the manufacturer. For FIBCs designed for four-point lifting, the suspension frame shall have the cross section shown in Figure B.1. For FIBCs designed for single-point lifting, the suspension frame shall have the cross section shown in Figure B.2. For FIBCs designed for two-point lifting, the suspension frame shall have the cross section shown in Figure B.1 or B.2.

B.2.1.3 The means of applying the force (upwards or downwards) shall be

- a) capable of at least the required test load,
- b) capable of a rate of (70 ± 20) kN/min, and
- c) fitted with a means of registering the applied force.

B.2.1.4 The suspension frame, the pressure plate (and any restraint used for the latter) shall be capable of resisting the forces applied during the test with minimal deformation.

B.2.2 Apparatus for use when an upward force is applied

B.2.2.1 Apparatus of the appropriate type illustrated in one of Figures B.3 to B.9 shall be used for FIBCs being subjected to top lift testing using top or base restraint and an upward force as in B.1 a). The figures are as follows.

- Figure B.3: Perspective view of an FIBC with four lifting devices using top restraint.
- Figure B.4: Elevation of an FIBC with two lifting devices using top restraint.

- Figure B.5: Elevation of an FIBC with the lifting devices formed by extensions of the body and using top restraint.
- Figure B.6: Elevation of a single-point lift FIBC with base restraint using one member restraining the pressure plate.
- Figure B.7: Similar to Figure B.6 but with two members restraining the pressure plate.
- Figure B.8: Elevation of an FIBC with two lifting devices using base restraint and one member restraining the pressure plate.
- Figure B.9: As Figure B.8 but with two members restraining the pressure plate.

B.2.2.2 Use of the apparatus illustrated in Figures B.6 to B.9 with base restraint involves connections passing through the body of the FIBC and its test contents. Rods are a suitable method of making such connections.

Considerable care shall be taken

- a) that the threads shall be separated with woven fabrics rather than be cut to permit passage of a rod, and
- b) to ensure that any rod passes through the base no closer than 20 mm to any base seams or joins. When, as with an FIBC having a seam or join running across the centre of the base, a single rod would need to pass within 20 mm of a seam or join, then two rods should be used as shown in Figures B.7 and B.9.

It is recommended that

- a conical adaptor be screwed to the top of any restraining rod and removed once the FIBC is in position for test, and
- nuts be used to connect the rod(s) to the pressure plate and to a restraint.

B.2.3 Apparatus for use when a downward force is used.

Apparatus of the type illustrated in Figure B.10 shall be used for FIBCs being subjected to top lift testing using an downward force as in B.1 b).

B.3 Procedure

B.3.1 Select, fill and condition each FIBC for cyclic top lift testing in accordance with 5.1, 5.2 and 5.3.

Any top panel not designed to contribute to the overall strength of the FIBC may be removed to allow the entry of the test apparatus. The area removed should be the minimum commensurate with efficient operation of the test apparatus.

B.3.2 Select any appropriate size of pressure plate in accordance with B.2.1.1 and position it above the contents. This size shall be sufficiently small and the positioning such that there will be no contact between the edge of the plate and the material of the FIBC during the test.

B.3.3 Apply an upwards or downwards force as appropriate. Increase the force at the rate of (70 ± 20) kN/min until the total force equivalent to the specified test load is registered. Remove the applied force.

Allow a dwell period of not more than 30 s before repeating the cycle. Repeat the test cycle until the specified number of cycles has been completed. Carry out a further test cycle to the appropriate load specified for the final test cycle.

Use the appropriate cycle from the following:

- heavy-duty reusable FIBC types: 70 cycles at a test load of $6 \times \text{SWL}$ and a final cycle at a test load of $8 \times \text{SWL}$
- standard-duty reusable FIBC types: 70 cycles at a test load of $4 \times \text{SWL}$ and a final cycle at a test load of $6 \times \text{SWL}$
- single-trip FIBC types: 30 cycles at a test load of $2 \times \text{SWL}$ and a final cycle at a test load of $5 \times \text{SWL}$.

After this test is complete, further loading may be applied until failure of the FIBC, to provide additional information. When this is done, the load at failure should, together with other relevant test observations, be recorded in a test report. There is no requirement, however, for the load at failure, if it is greater than the specified test load, to be noted in the certificate or reflected in the marking of the FIBC.

B.4 Expression of results

Express the results of the test, including whether leakage of contents, breakage or loosening of lifting devices, or protrusion of the inner liner, if fitted, took place.

In Figures B.1 and B.2 all dimensions are nominal where they are not toleranced.

STANDARDSISO.COM : Click to view the full PDF of ISO 21898:2004

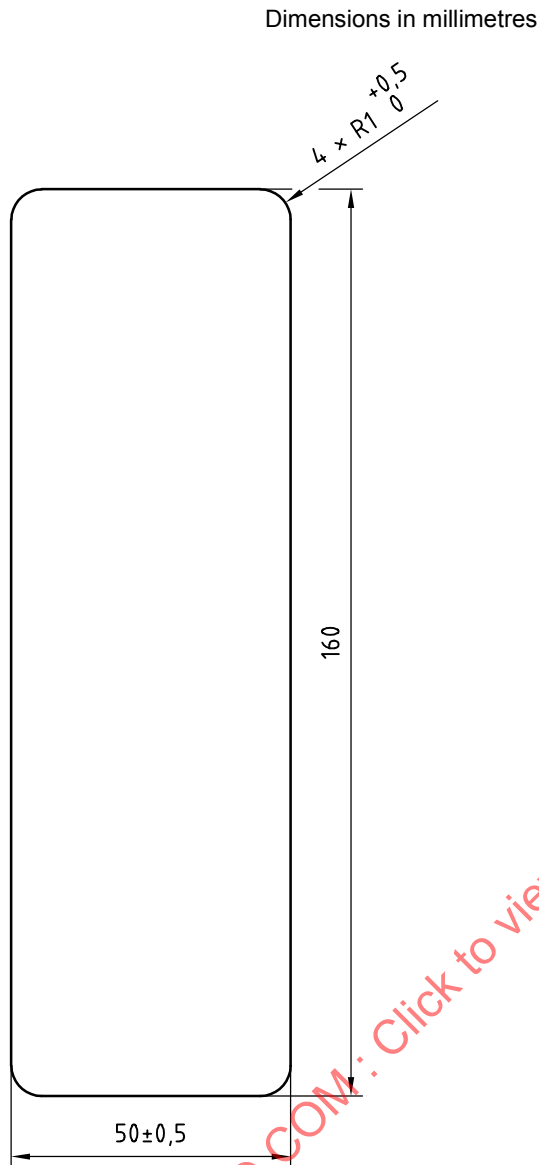

All radii marked shall be 1,0 mm with a tolerance of $\begin{matrix} +0,5 \\ 0 \end{matrix}$ mm. The horizontal dimension shall be $50 \text{ mm} \pm 0,5 \text{ mm}$.

Figure B.1 — Cross section of suspension frame — Top lift test, FIBCs for four- and two-point lifting

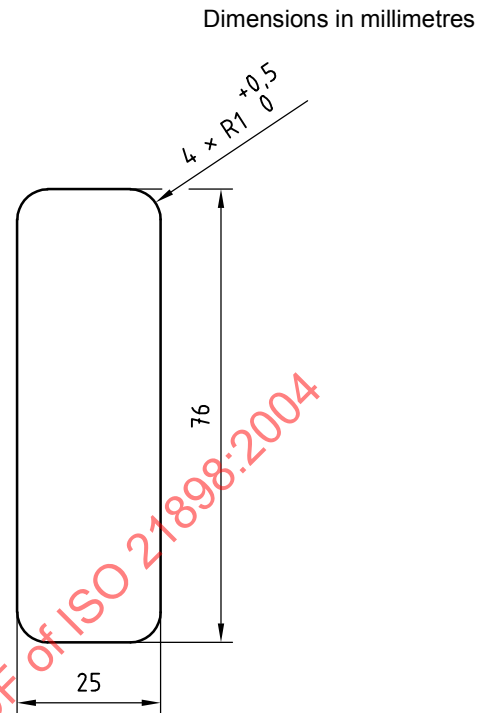

All radii marked shall be 1 mm with a tolerance of $\begin{matrix} +0,5 \\ 0 \end{matrix}$ mm.

Figure B.2 — Cross section of suspension frame — Top lift test, FIBCs for single- and two-point lifting

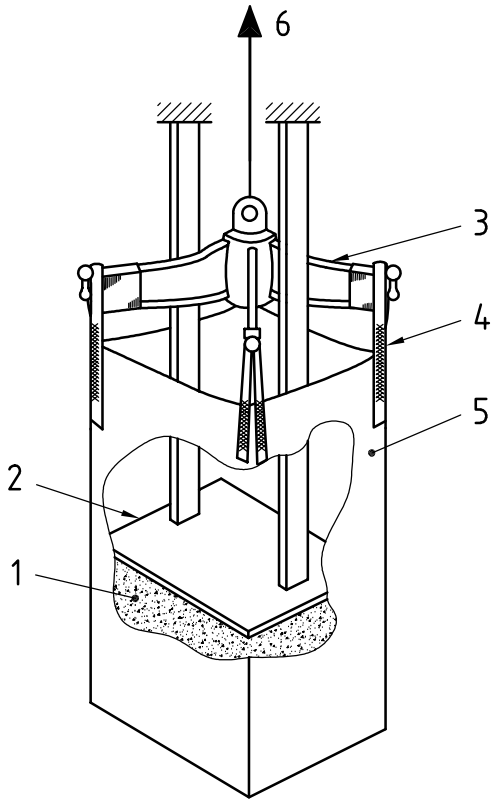

Key

- 1 filler material
- 2 pressure plate
- 3 suspension frame
- 4 FIBC lifting device
- 5 FIBC
- 6 hoisting device

Figure B.3 — Perspective view of an FIBC with four lifting devices being tested using top restraint

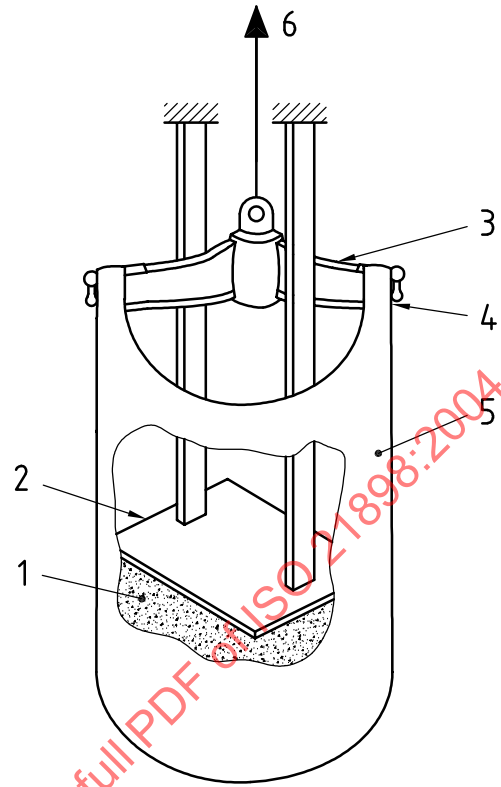

Key

- 1 filler material
- 2 pressure plate
- 3 suspension frame
- 4 FIBC lifting device
- 5 FIBC
- 6 hoisting device

Figure B.4 — Perspective view of an FIBC (with cut-out) with two lifting devices using top restraint

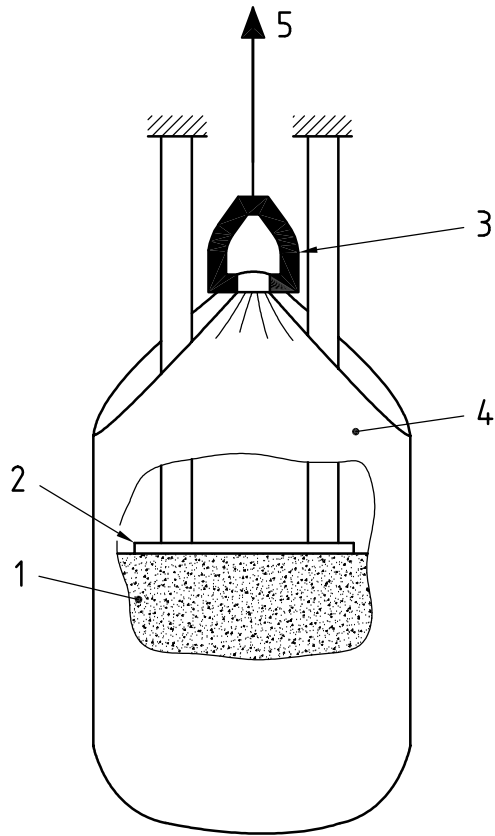

Key

- 1 filler material
- 2 pressure plate
- 3 suspension frame
- 4 FIBC
- 5 hoisting device

Figure B.5 — Elevation of an FIBC with the lifting devices formed by extensions of the body and using top restraint

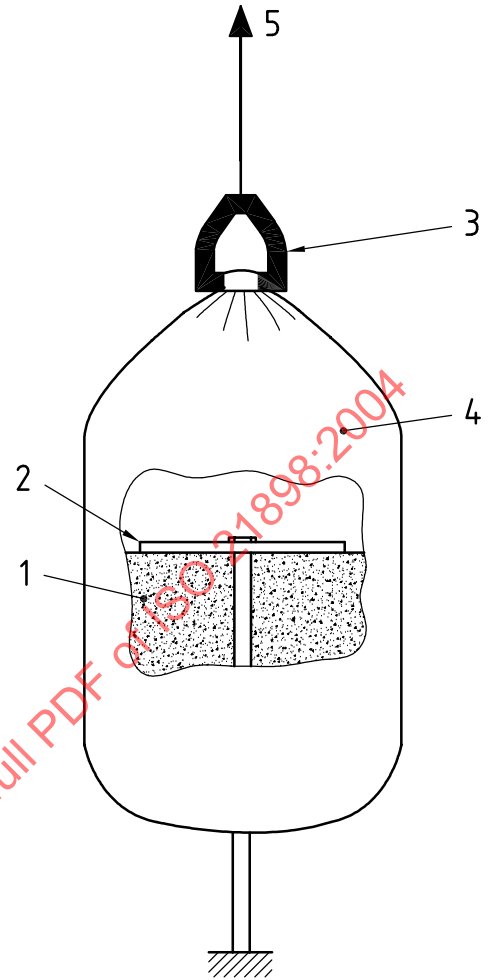

Key

- 1 filler material
- 2 pressure plate
- 3 suspension frame
- 4 FIBC
- 5 hoisting device

Figure B.6 — Elevation of a single-point lift FIBC with base restraint using one member restraining the pressure plate

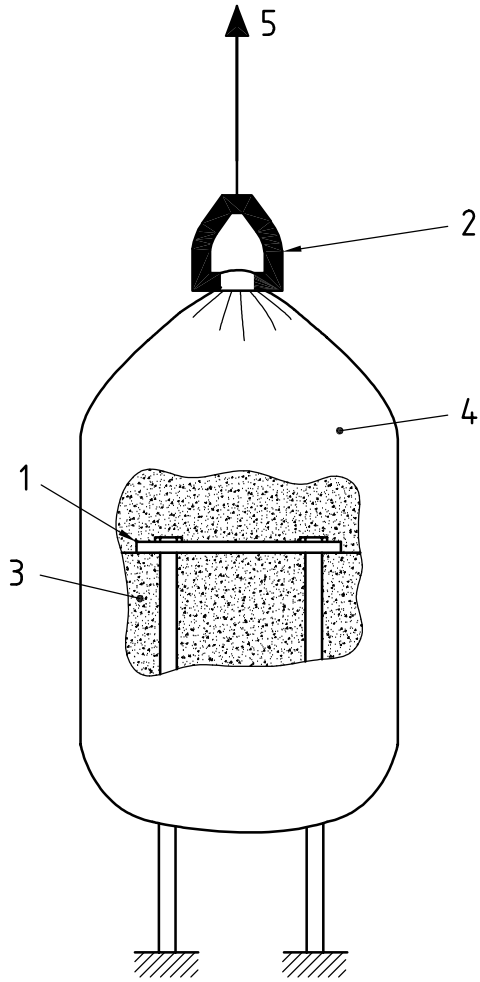

Key

- 1 pressure plate
- 2 suspension frame
- 3 filler material
- 4 FIBC
- 5 hoisting device

Figure B.7 — As Figure B.6 but with two members restraining the pressure plate

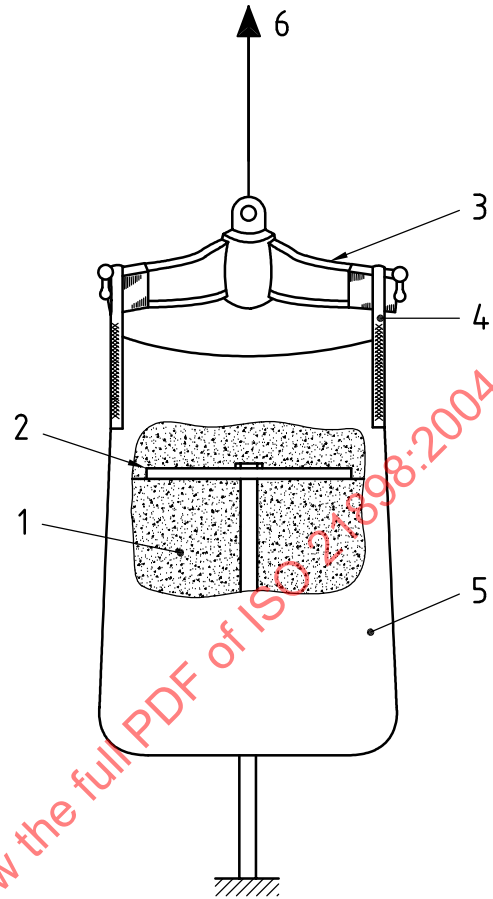

Key

- 1 filler material
- 2 pressure plate
- 3 suspension frame
- 4 FIBC lifting device
- 5 FIBC
- 6 hoisting device

Figure B.8 — Elevation of an FIBC with two lifting devices using base restraint and one member restraining the pressure plate

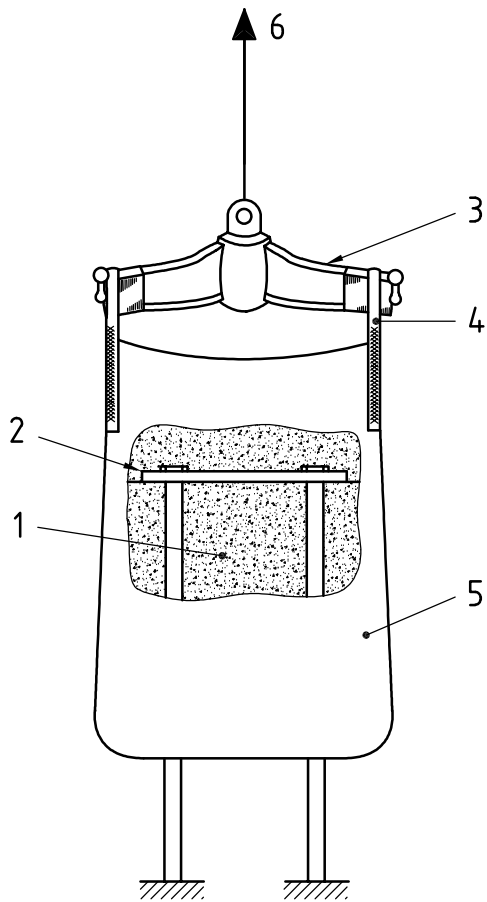

Key

- 1 filler material
- 2 pressure plate
- 3 suspension frame
- 4 FIBC lifting device
- 5 FIBC
- 6 hoisting device

Figure B.9 — As Figure B.8 but with two members restraining the pressure plate

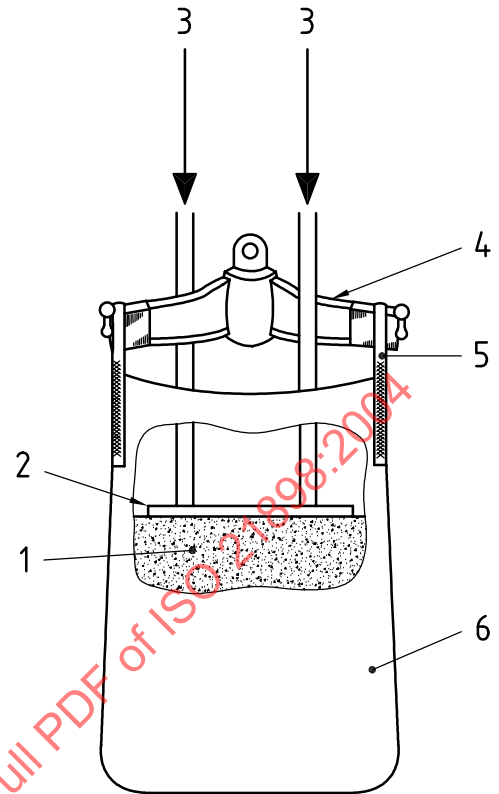

Key

- 1 filler material
- 2 pressure plate
- 3 download force
- 4 suspension frame
- 5 FIBC lifting device
- 6 FIBC

Figure B.10 — Elevation of an FIBC with two lifting devices being top lift tested using a downward force

Annex C (normative)

Compression/stacking test

C.1 Principle

The filled FIBC is loaded to the specified test load using either a compression tester or a dead load. At the end of the test period, the FIBC is checked for loss of contents and for deterioration of the body which would render it unsafe for transport and storage.

C.2 Apparatus

Use apparatus as described in ISO 12048, or a flat plate with the appropriate dead load.

C.3 Procedure

Fill and condition the FIBC under test in accordance with 5.2.1 and 5.2.2. Use one of the methods described in ISO 12048, or apply the load by appropriate weights loaded to a flat plate placed on top of the FIBC.

C.4 Calculation of the load to be applied

The load to be placed on the FIBC shall be four times its SWL. The compression load of $4 \times \text{SWL}$ shall not be taken as the allowable stacking load in service. Other factors which affect stacking are the actual contents used in service, FIBC dimensions and design, stacking method, etc.

C.5 Duration of the test

The duration of loading shall be 6 h.

C.6 Expression of results

Express the results of the test, including whether loss of contents or deterioration of the body of the FIBC occurred.

Annex D (informative)

Guidance on selection and use of FIBCs

D.1 General

There are many different designs of FIBCs in common use, but these can be divided into three main categories:

- a) heavy-duty reusable, made, for example, of polymeric fabric continuously coated on one or both sides with a plastics material such as polyvinyl chloride;
- b) standard-duty reusable, made, for example, of polyolefin fabric, coated or uncoated, with or without an inner liner of plastics film, and used mainly in closed loop between filler and discharge of the FIBC;
- c) single-trip, made, for example, of polyolefin fabrics or paper, coated or uncoated, with or without an inner liner of plastics film.

Seaming or joining of the materials is usually by means of stitching, glueing and/or welding, although other means may be used.

An FIBC may be so designed that, when filled and raised by its top lift device(s), the resultant forces may be either

- absorbed by the body and the lifting devices, where the walls are extended to form lifting loop(s), or where other lifting devices are attached to the upper part of the walls, or
- partially absorbed by separate or integral lifting devices which pass the bag to form the support.

Table D.1 gives an essential checklist to be undertaken before selecting an FIBC for use.

D.2 Selection of FIBCs

When selecting an FIBC for use, consideration should be given to the following:

- a) the physical and chemical properties of the intended contents of the FIBC, such as
 - 1) bulk density,
 - 2) flow characteristics,
 - 3) degree of aeration,
 - 4) particle size and shape,
 - 5) compatibility with the materials used for the construction of the FIBC,
 - 6) fill temperature,
 - 7) whether the intended contents are foodstuffs, when special conditions normally apply;
- b) the methods to be used for filling, handling, transporting, storing and emptying the FIBC;

- c) the number of trips required, the number of times the bag is lifted on each trip, and the environmental conditions likely to be encountered;
- d) general environmental considerations.

D.3 Storage of empty FIBCs

Empty FIBCs and liners should be stored in such a manner that accidental damage, exposure to sunlight or extreme climatic conditions, and contact with substances likely to degrade the materials are avoided.

Where liners are supplied with the FIBCs they may be delivered either fitted inside the FIBCs or separately. In both cases, care should be taken to avoid contamination.

Liners are vulnerable to damage which may not always be visibly obvious, and therefore should be given particularly careful handling and storage.

D.4 Filling FIBCs

FIBCs are normally filled suspended using the lifting device(s) and with the base of the bag on or near the ground or a pallet. Other methods may be acceptable in consultation with the manufacturer or supplier.

If the FIBC has a discharge spout or other discharging device, this should be tied off or closed before filling.

Before filling with material at temperatures above 60 °C, the manufacturer or supplier should be consulted.

D.5 Stability of filled FIBCs

The FIBCs should be filled so that the ratio of filled height to base is between 0,5 and 2,0, using as base dimension

- a) the diameter of FIBCs with a circular cross-section, or
- b) the length of the shorter side for FIBCs with a rectangular cross-section.

NOTE 1 Other major factors which affect the stability of filled FIBCs are the flow characteristics of the contents, free space and air entrapment.

NOTE 2 Stability can be often improved by vibration during or after filling to remove entrapped air and cause compaction.

D.6 Lifting of filled FIBCs

Before lifting any FIBC

- a) it should be inspected for any damage which may render it unsafe,
- b) the lifting loops or other lifting devices should be positioned according to the manufacturer's or supplier's instructions, and
- c) the hooks, bars or fork-lift arms employed for lifting should be inspected to ensure that they have rounded edges with a radius greater than the diameter or thickness of the suspension of the FIBC and/or be protected by wrapping. The rounded edges should have a minimum radius of 5 mm. The necessary characteristics are shown in Figure D.1.

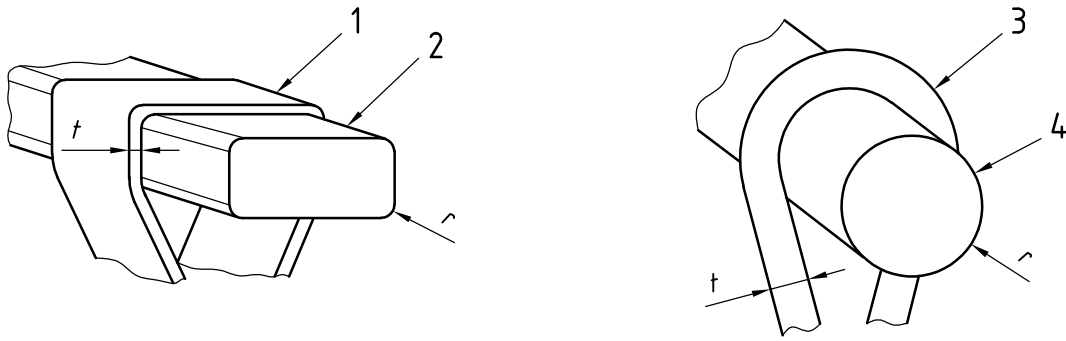
**Key**

- 1 FIBC suspension (e.g. webbing loop)
- 2 lifting device (e.g. fork-lift arm)
- 3 FIBC suspension (e.g. rope)
- 4 lifting device (e.g. fork-lift arm or crane)

NOTE 1 The value of r should be greater than t . The minimum value of r is 5 mm.

NOTE 2 When the FIBC is suspended, personnel should be excluded from the area under the FIBC.

Figure D.1 — Lifting of FIBCs

D.7 Storage of filled FIBCs

Storage of filled FIBCs at temperatures above 50 °C should be avoided, except with the approval of the manufacturer or supplier.

Filled FIBCs should have any top closures properly closed before storage.

Except for FIBCs which have been specifically designed for outdoor storage, all FIBCs stored outdoors

- a) should be sheeted over to prevent water collection on the tops of FIBCs,
- b) should not be stored in standing water, and
- c) should be protected against rays of sunshine.

D.8 Emptying of filled FIBCs

FIBCs may be emptied by suction and by certain types of blowing, but they are usually emptied by gravity. The flow characteristics of the contents and the cost of ancillary equipment will generally dictate which method is chosen.

When emptying by gravity, personnel should not stand under the FIBC, nor put their arms between the base of the FIBC and a receiving vessel, or similar, except where the FIBC is supported.

D.9 Inspection of heavy-duty and standard-duty FIBCs

Before reuse of FIBCs, consideration should be given to the possibility of contamination from previous contents.

Before reuse, FIBCs should be thoroughly examined for damage to stitching/glueing/welding, and for surface abrasion, cuts, tears or any other damage to the bag. Particular attention should be paid to the lifting loops or devices and their attachments. The examination should look for signs of the following.

- a) **Abrasion:** The effects of abrasion are variable, but some loss in strength is to be expected. In extreme cases, the fabric becomes so worn that the outer yarns of the weave are severed. On lifting loops or devices, localized areas of abrasion may be present caused by handling equipment with sharp edges, and these areas may result in a serious loss in strength.
- b) **Cuts, contusions:** Cuts, particularly in the lifting loops or devices, may result in serious loss of strength.
- c) **Ultraviolet degradation and/or chemical attack:** These may be indicated by the softening of the material (sometimes with discoloration), so that the outer surface can be rubbed off or plucked off and, in extreme cases, the outer surface may become powdered.
- d) **Damage to coatings:** Some FIBCs are manufactured from coated polyolefin fabric, and the coating may be on the inside and/or outside of the bag. Consideration should be given to possible contamination of the contents by an unacceptable level of coating fragments if an inside coating is damaged, and to the increased possibility of moisture ingress (particularly if the contents are hygroscopic) when damage occurs to either the inside and/or outside coatings.

When damage affecting the strength of the FIBC is discovered, the FIBC should be taken out of service immediately.

D.10 Repair of heavy-duty FIBCs

Repairs should be carried out so that the repaired FIBC is capable of meeting the requirements of new FIBCs as marked on the label.

Before undertaking any repairs, the manufacturer or supplier should always be consulted. Factors which should be taken into account in deciding whether the FIBC is field repairable, factory repairable or not repairable include

- a) the materials of construction,
- b) the type and area of damage,
- c) the age of the FIBC,
- d) the conditions to which the FIBC has been subjected during service, and
- e) the location of the damage.

Table D.1 — How to use FIBCs

Do	Don't
Do select the right FIBC for the job in consultation with the manufacturer or supplier	Don't choose FIBCs without consulting the manufacturer or supplier
Do read the instruction label on the FIBC	Don't exceed the SWL in any circumstances
Do inspect reusable FIBCs before refilling	Don't fill the FIBCs unevenly
Do check that the discharge spout is closed off before filling	Don't stop or start suddenly during transportation
Do ensure that the filled FIBC is stable	Don't subject FIBCs to snatchlift and/or jerk stops
Do close the top inlet correctly	Don't drag FIBCs
Do use lifting gear of sufficient capacity to take the suspended load	Don't allow personnel under suspended FIBCs
Do adjust the distance between fork-lift arms to the correct width for the FIBC being handled	Don't allow FIBCs to project over the side of a vehicle or pallet
Do tilt the mast of the fork-lift truck rearwards to an appropriate angle	Don't tilt the mast of the fork lift forward
Do ensure that crane hooks, bars or fork-lift arms used for lifting are of adequate size and are rounded to at least the thickness of the sling, belt or rope suspension, with a minimum radius of 5 mm	Don't withdraw the fork-lift arms prior to relieving all the load on the lifting devices
Do take appropriate measures with regard to dust control	Don't stack FIBCs unless sure of their stability
Do consider the possibility of static electricity hazards	Don't use FIBCs in new conditions without consulting the manufacturer or supplier
Do protect the FIBCs from rain and/or prolonged sunlight	Don't reuse single-trip FIBCs
Do ensure the FIBCs are adequately secured in transportation	Don't repair heavy-duty reusable FIBCs unless the as-new requirements can be met