

# ***National Electrical Code<sup>®</sup> 1987***

National Fire Protection Association  
Batterymarch Park, Quincy MA 02269



## NOTICE

All questions or other communications relating to this document should be sent only to NFPA Headquarters, addressed to the attention of the Committee responsible for the document.

For information on the procedures for requesting Technical Committees to issue Formal Interpretations, proposing Tentative Interim Amendments, proposing amendments for Committee consideration, and appeals on matters relating to the content of the document, write to the Secretary, Standards Council, National Fire Protection Association, Batterymarch Park, Quincy, MA 02269.

A statement, written or oral, that is not processed in accordance with Section 16 of the Regulations Governing Committee Projects shall not be considered the official position of NFPA or any of its Committees and shall not be considered to be, nor be relied upon as, a Formal Interpretation.

Users of this document should consult applicable Federal, State and local laws and regulations. NFPA does not, by the publication of this document, intend to urge action which is not in compliance with applicable laws and this document may not be construed as doing so.

### **Policy Adopted by NFPA Board of Directors on December 3, 1982**

The Board of Directors reaffirms that the National Fire Protection Association recognizes that the toxicity of the products of combustion is an important factor in the loss of life from fire. NFPA has dealt with that subject in its technical committee documents for many years.

There is a concern that the growing use of synthetic materials may produce more or additional toxic products of combustion in a fire environment. The Board has, therefore, asked all NFPA technical committees to review the documents for which they are responsible to be sure that the documents respond to this current concern. To assist the committees in meeting this request, the Board has appointed an advisory committee to provide specific guidance to the technical committees on questions relating to assessing the hazards of the products of combustion.

---

**Licensing Provision** — This document is copyrighted by the National Fire Protection Association (NFPA).

**1. Adoption by Reference** — Public authorities and others are urged to reference this document in laws, ordinances, regulations, administrative orders or similar instruments. Any deletions, additions and changes desired by the adopting authority must be noted separately. Those using this method are requested to notify the NFPA (Attention: Secretary, Standards Council) in writing of such use. The term "adoption by reference" means the citing of title and publishing information only.

*Continued on inside back cover*

# If you use the NEC<sup>®</sup> you need this Handbook.

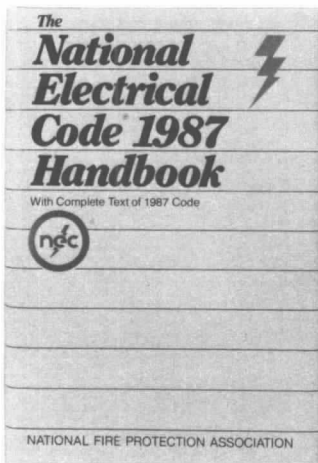

The 1987 National Electrical Code Handbook. It's the "bible" of the electrical industry. A necessary companion to your 1987 NEC. The Handbook contains the complete 1987 Code together with concise explanations and clear examples by the Nation's leading Code experts. Plus hundreds of explanatory diagrams, tables, photos and illustrations. It provides insight that often escapes long-time Code users and also helps beginners with basic principles.

Order your copy today. Call, toll-free, 1-800-344-3555, 8:30 AM to 8:00 PM, ET. Or complete and mail the attached postage-paid reply card.

## Rush me the 1987 National Electrical Code<sup>®</sup> Handbook.

QTY.

\_\_\_\_\_ Copy(ies) NEC Handbook (J7-70-87-HB) \$ \_\_\_\_\_  
\$39.50 (Members \$35.55)

\_\_\_\_\_ Copy(ies) 1987 NEC Looseleaf (J7-70-87-LL) \$ \_\_\_\_\_  
\$24.50 (Members \$22.05)

(Prices guaranteed through December 31, 1987)

Handling \$ \_\_\_\_\_

Total \$ \_\_\_\_\_

NFPA Member Number \_\_\_\_\_

Check Enclosed     Please bill me     VISA     MASTERCARD

Card No. \_\_\_\_\_ Exp. date \_\_\_\_\_

Signature \_\_\_\_\_

Name \_\_\_\_\_

Address \_\_\_\_\_

City \_\_\_\_\_ State \_\_\_\_\_ Zip \_\_\_\_\_

Phone \_\_\_\_\_

To order, call toll-free 1-800-344-3555, 8:30 AM to 8:00 PM, ET Monday through Friday.  
Or complete and mail the attached postage-paid reply card.

# New! Looseleaf version of the 1987 NEC

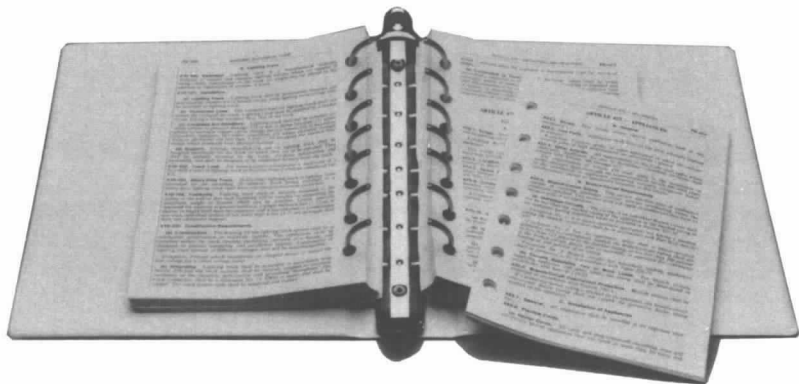

- Sturdy, washable, vinyl binder 7 1/4 x 9 inches.
- 7 Ring Binder for easy access to individual pages.
- Lays flat for convenient use.
- Convenient binder pocket to store papers, etc.
- Contains complete text of the 1987 NEC.



NO POSTAGE  
NECESSARY  
IF MAILED  
IN THE  
UNITED STATES

## **BUSINESS REPLY MAIL**

FIRST CLASS MAIL PERMIT NO. 3376 QUINCY, MA

POSTAGE WILL BE PAID BY ADDRESSEE

NATIONAL FIRE PROTECTION ASSOCIATION  
BATTERYMARCH PARK  
QUINCY, MASSACHUSETTS 02269





# You can vote for a change. Join NFPA today.

Your vote can make a difference. As an NFPA member you can take an active role in the acceptance of the National Electrical Code.\*

The National Fire Protection Association is dedicated to protecting lives and property from fire and electrical hazards. NFPA accomplishes this through its sponsorship of the most widely used code in the world—the National Electrical Code.

As an NFPA member, you are part of an increasingly powerful and persuasive group of professionals with a special interest in safety. Your Association membership entitles you to apply to the NFPA Sections devoted to Electrical Safety—**The Chief Electrical Inspectors Section** brings together public officials who work to minimize electrically-related accidents and fires. **The Electrical Section** brings together people with a common interest on issues involving electrical safety.

Give your voice a vote. Join NFPA.

Call, toll-free, 1-800-344-3555, 8:30 AM to 8:00 PM, ET, Monday through Friday. Or complete and mail the attached postage-paid reply card.

---

## Sign me up as an NFPA member.

Name \_\_\_\_\_ Title \_\_\_\_\_

Organization/Business \_\_\_\_\_

Address \_\_\_\_\_ Phone \_\_\_\_\_

City \_\_\_\_\_ State \_\_\_\_\_ Zip \_\_\_\_\_

Signature \_\_\_\_\_ Date \_\_\_\_\_

I am interested in membership in the Section indicated. (Note: NFPA Membership includes one Section membership. Additional Section Memberships cost \$15.00 each.)

Chief Electrical Inspectors Section     Electrical Section

## NFPA Membership Fee: (1 year): \$60.00

Please bill me.     My check for \$ \_\_\_\_\_ is enclosed.

Charge my NFPA Membership Fee to     VISA     MASTERCARD

Card. No. \_\_\_\_\_ Exp. Date \_\_\_\_\_

Signature \_\_\_\_\_

(Required for Credit Card Charges.)

# Take Advantage of NFPA Membership.

- Voting privileges.
- Section membership.
- 10 % discount on all products, publications, services.
- Subscription to Fire Journal and Fire News.
- NFPA Seminars, Workshops, and Annual and Fall Meetings.
- Technical Assistance.

## Join NFPA Today.

Call 1-800-344-3555, 8:30 AM to 8:00 PM, ET, Monday through Friday. Or complete and mail the attached postage-paid reply card.



NO POSTAGE  
NECESSARY  
IF MAILED  
IN THE  
UNITED STATES

### **BUSINESS REPLY MAIL**

FIRST CLASS MAIL PERMIT NO. 3376 QUINCY, MA

POSTAGE WILL BE PAID BY ADDRESSEE

NATIONAL FIRE PROTECTION ASSOCIATION  
BATTERYMARCH PARK  
QUINCY, MASSACHUSETTS 02269

Errata

**NFPA 70**  
**National Electrical Code**  
1987 Edition

**Reference: 370-11**

The National Electrical Code Committee notes the following error in NFPA 70-1987.

1. *Page 261, Section 370-11: "(1.59 mm)" should be changed to "(3.18 mm)".*

Copyright © 1987 All Rights Reserved  
NATIONAL FIRE PROTECTION ASSOCIATION, INC.

Errata

**NFPA 70**  
**National Electrical Code**  
1987 Edition

**Reference: 110-16(c), 370-13**

The National Electrical Code Committee notes the following errors in the 1987 edition of the *National Electrical Code*, NFPA 70-1987.

1. *Section 110-16(c): The third (last) paragraph should be second paragraph of Exception No. 2, and in italics.*
2. *Section 370-13: In first paragraph change "a through f" to "a through h".*

Copyright © 1987 All Rights Reserved  
NATIONAL FIRE PROTECTION ASSOCIATION, INC.

Errata

# NFPA 70

## National Electrical Code

1987 Edition

**Reference: 110-33(a), 336-4(a)(3), 820-13(a)**

The National Electrical Code Committee notes the following errors in NFPA 70-1987.

1. *Page 24, Section 110-33(a): The second paragraph (following Exception No. 2) should be in italics and become a second paragraph of Exception No.2.*
2. *Page 216, Section 336-4(a)(3): Change reference from "511-2" to "511-3".*
3. *Page 712, Section 820-13(a): In the third line, delete "or coaxial cable" and the marginal rule. Add "or coaxial cable" between "Class I" and "circuit" in line 1 of Exception No. 1, and add marginal rule opposite line 1 of Exception No. 1.*

Copyright © 1987 All Rights Reserved  
NATIONAL FIRE PROTECTION ASSOCIATION, INC.

Errata

**NFPA 70**  
**National Electrical Code**  
1987 Edition

The National Electrical Code Committee notes the following errors in NFPA 70-1987.

1. **Page 131, Section 300-15(b), Exception No. 5, FPN:** Change references from "550-8(j)" and "551-14(e)" to "550-10(j)" and "551-16(e)".
2. **Page 128, Section 300-5(d):** In lines 3 and 4, change references from "Table 300-5(a)" to "Table 300-5".
3. **Page 179-196, Tables 310-77 through 310-84:** In heading, change "104°F" to "194°F".

Copyright © 1987 All Rights Reserved  
NATIONAL FIRE PROTECTION ASSOCIATION

Errata

# NFPA 70

## National Electrical Code®

1987 Edition

The National Electrical Code Committee notes the following errors in NFPA 70-1987.

1. Section 230-22\*. Delete the fine print note (FPN).
2. Section 310-5\*. Delete the fine print note (FPN).
3. Table 3A, Chapter 9. The data for sizes 12, 4, 2, and 1 AWG conductors is missing. This data is the same as in the 1984 NEC. A complete Table 3A with the corrections made is shown below.
4. Section A-517-64, Appendix A. Change referenced paragraph to 8-3.3.

**Table 3A. Maximum Number of Conductors in Trade Sizes of Conduit or Tubing**  
(Based on Table 1, Chapter 9)

Conduit Trade Size (Inches)		1/2	3/4	1	1 1/4	1 1/2	2	2 1/2	3	3 1/2	4	5	6
Type Letters	Conductor Size AWG, MCM												
TW, RUH, XHHW (14 thru 8)	14	9	15	25	44	60	99	142					
	12	7	12	19	35	47	78	111	171				
	10	5	9	15	26	36	60	85	131	176			
	8	2	4	7	12	17	28	40	62	84	108		
RHW and RHH (without outer covering), THW	14	6	10	16	29	40	65	93	143	192			
	12	4	8	13	24	32	53	76	117	157			
	10	4	6	11	19	26	43	61	95	127	163		
	8	1	3	5	10	13	22	32	49	66	85	133	
TW, THW,	6	1	2	4	7	10	16	23	36	48	62	97	141
	4	1	1	3	5	7	12	17	27	36	47	73	106
	3	1	1	2	4	6	10	15	23	31	40	63	91
	2	1	1	2	4	5	9	13	20	27	34	54	78
FEPB (6 thru 2), RHW and RHH (without outer covering)	1		1	1	3	4	6	9	14	19	25	39	57
	1/0		1	1	2	3	5	8	12	16	21	33	49
	2/0		1	1	1	3	5	7	10	14	18	29	41
	3/0		1	1	1	2	4	6	9	12	15	24	35
250 300 350 400 500	4/0		1	1	1	1	3	5	7	10	13	20	29
	250			1	1	1	2	4	6	8	10	16	23
	300			1	1	1	2	3	5	7	9	14	20
	350			1	1	1	1	3	4	6	8	12	18
	400			1	1	1	1	2	4	5	7	11	16
600 700 750	500			1	1	1	1	1	3	4	6	9	14
	600					1	1	1	3	4	5	7	11
	700					1	1	1	2	3	4	7	10
	750					1	1	1	2	3	4	6	9

Note: This table is for concentric stranded conductors only. For cables with compact conductors, the dimensions in Table 5A shall be used.

\*FPN not printed in all copies of 1987 NEC.

© 1986 NFPA, All Rights Reserved

## NFPA 70

### *National Electrical Code®*

#### 1987 Edition

#### **1987 Edition of the *National Electrical Code***

This 1987 edition of the *National Electrical Code* (NFPA 70-1987) was adopted by the National Fire Protection Association, Inc. on May 21, at its 1986 Annual Meeting, in Atlanta, GA, and was released by the Standards Council on July 10, 1986. It was approved by the American National Standards Institute on July 30, 1986. This 1987 edition supersedes all other previous editions, supplements, and printings dated 1897, 1899, 1901, 1903, 1904, 1905, 1907, 1909, 1911, 1913, 1915, 1918, 1920, 1923, 1925, 1926, 1928, 1930, 1931, 1933, 1935, 1937, 1940, 1942, 1943, 1947, 1949, 1951, 1953, 1954, 1955, 1956, 1957, 1958, 1959, 1962, 1965, 1968, 1971, 1975, 1978, 1981, and 1984.

Changes in this 1987 edition of the *National Electrical Code* (as compared with the 1984 edition) are indicated by vertical lines in the margin.

The location (in the 1984 edition) of material not appearing in the 1987 edition, and not identified as a change by a vertical line, is identified by a bullet (●) in the margin. Changes in section and table numbers are not identified.

This Code is purely advisory as far as the NFPA and ANSI are concerned but is offered for use in law and for regulatory purposes in the interest of life and property protection. Anyone noticing any errors should notify the Secretary of the National Electrical Code Committee at the NFPA Executive Office.

### **History and Development of the *National Electrical Code***

The National Fire Protection Association has acted as sponsor of the *National Electrical Code* since 1911. The original Code document was developed in 1897 as a result of the united efforts of various insurance, electrical, architectural, and allied interests.

In accordance with the provisions of the NFPA Regulations Governing Committee Projects, a National Electrical Code Technical Committee Report containing proposed amendments to the 1984 *National Electrical Code* was published by the NFPA in June, 1985. This report recorded the actions of the various Code-Making Panels and the Correlating Committee of the National Electrical Code Committee on each proposal that had been made to revise the 1984 Code. The report was circulated to all members of the National Electrical Code Committee, and was made available to other interested NFPA members and to the public for review and comment. Following the close of the public comment period, the Code-Making Panels met, acted on



each comment and reported their action to the Correlating Committee. The NFPA published the National Electrical Code Technical Committee Documentation in April, 1986, which recorded the actions of the Code-Making Panels and the Correlating Committee on each public comment to the National Electrical Code Technical Committee Report. The NFPA also published the Advanced Printing of the Proposed 1987 *National Electrical Code* in April, 1986, to permit the study and evaluation by those interested, prior to formal action on the Committee Report by the 1986 NFPA Annual Meeting. The National Electrical Code Technical Committee Report and the National Electrical Code Technical Committee Documentation were presented to the 1986 NFPA Annual Meeting for adoption. The proceedings of that adoption are published in the September 1986 issue of the *NEPA Fire Journal*®.

The NFPA has an Electrical Section that provides particular opportunity for NFPA members interested in electrical safety to become better informed and to contribute to the development of the *National Electrical Code* and other NFPA electrical standards. Each of the Code-Making Panels and the Chairman of the Correlating Committee reported their recommendations to meetings of the Electrical Section at the 1986 NFPA Annual Meeting. The Electrical Section thus had opportunity to discuss and review the report of the National Electrical Code Committee prior to the adoption of this edition of the Code by the Association.

The time schedule for processing the 1990 edition of the *National Electrical Code* is as follows:

### 1990 NATIONAL ELECTRICAL CODE SCHEDULE

#### (1989 ANNUAL MEETING)

Nov. 6, 1987 (5:00 PM E.S.T.)	Receipt of Proposals
Jan. 4-23, 1988	Code-Making Panel Meetings
May 9-13, 1988	Correlating Committee Meeting
June 17, 1988	Technical Committee Report of <i>NEC</i> to Mailing House
Oct. 21, 1988 (5:00 PM E.D.S.T.)	Closing Date for Comments
Nov. 28- Dec. 9, 1988	Code-Making Panel Meetings
March 6-10, 1989	Correlating Committee Meeting
April 7, 1989	Technical Committee Documentation of <i>NEC</i> to Mailing House
May 15-18, 1989	Annual Meeting (Washington, DC)

Anyone may submit proposals to amend the 1987 Code. Sample forms for this purpose may be obtained from the Secretary of the Standards Council at NFPA Headquarters.

The NFPA *Electrical Code for One- and Two-Family Dwellings*, NFPA 70A-1987, is an abridged version of the 1987 text, edited only as dictated to eliminate extraneous material not of concern to this type occupancy, and to place in the text only the more popular types of wiring methods, not to exclude any other type authorized by the complete Code.

The *National Electrical Code Handbook* is published by the National Fire Protection Association. This text was prepared by the NFPA Chief Electrical Engineer and the NFPA Electrical Field Service Specialists.

### Method of Submitting Proposal to Revise the National Electrical Code

The following is based on the NFPA Regulations Governing Committee Projects, adopted by the Board of Directors on December 3, 1977, with amendments of December 9, 1978, June 19, 1979, December 8, 1979, June 17, 1980, October 29, 1980, December 5, 1980, March 20, 1981, December 3, 1982, December 2, 1983, December 7, 1984, and December 6, 1985.

A proposal to revise the 1987 edition of the *National Electrical Code* must be submitted so that the proposal is received at NFPA Headquarters by November 6, 1987, as indicated in the time schedule for the 1990 *National Electrical Code*. A proposal received after this date will be returned to the submitter. The proposal is to be sent to the Secretary of the Standards Council at NFPA Headquarters, Batterymarch Park, Quincy, MA 02269.

Each proposal shall include:

- (a) identification of the submitter (the person's name) and his or her affiliation (i.e., committee, organization, company), where appropriate, and
- (b) an indication that the proposal is for revision of the 1987 *National Electrical Code* and identification of the specific section number, table number (or equivalent identification) of the section, etc. to be revised, and
- (c) a statement of the problem and substantiation for proposal, and
- (d) the proposed text of the proposal, including the wording to be added, revised (and how revised), or deleted.

Proposals that do not include all of the above information may be returned to the submitter by the National Electrical Code Committee without Committee action.

It is preferred that the forms available from NFPA for submittal of proposals be used. A separate proposal form should be used for revision of each section of the Code.

An example of a properly submitted (although not necessarily technically correct or acceptable) proposal appears on the following page.

#### NOTICE

Following issuance of this edition of NFPA 70, the *National Electrical Code*, two appeals were filed with the NFPA Board of Directors.

The first appeal requests that the NEC Committee reconsider a proposal that Sections 325-1 and 325-21, and Table 325-21, be revised to recognize integrated gas spacer cable rated up to 35,000 volts.

The second appeal requests that Sections 331-3 and 331-4 be revised to return to the 1984 NEC wording. In addition, the appeal requests that the language of Section 331-4 in the 1984 edition be amended to prohibit use of electrical nonmetallic tubing in certain occupancies.

NFPA will announce the disposition of the appeals when they have been determined. Anyone wishing to receive automatically the disposition of the appeals should notify in writing the Secretary, Standards Council, NFPA Headquarters.

## FORM FOR PROPOSALS ON NFPA TECHNICAL COMMITTEE DOCUMENTS

Mail to: Secretary, Standards Council  
National Fire Protection Association, Batterymarch Park, Quincy, Massachusetts 02269

Date Oct. 1, 1987 Name John Doe Tel. No. (617) 770-3000

Address 1234 Main St., Anywhere, MA 02269

Representing (Please indicate organization, company or self) Foreign Manufacturing Co., Ltd.

1. a) Document Title: National Electrical Code NFPA No. & Year: 70-1987

b) Section/Paragraph: 250-5(b)

2. Proposal recommends: (Check one)  new text  
 revised text  
 deleted text.

3. Proposal (include proposed new or revised wording, or identification of wording to be deleted):

Revise Section 250-5(b) to add a new subparagraph (3) as follows, changing existing subparagraphs (3) and (4) to (4) and (5):

(3) Where the system is nominally rated 380Y/220-volt, 3-phase, 4-wire in which the midpoint of one phase is used as a circuit conductor.

4. Statement of Problem and Substantiation for Proposal:

Such systems are not now required to be grounded by the National Electrical Code. This wiring system is in common use outside of the United States. It is the equivalent of the 208Y/120-volt, 3-phase, 4-wire and 480Y/277-volt 3-phase, 4-wire systems often used in the United States and requiring grounding in accordance with Sections 250-5(a)(1) and (a)(2), except for the voltage involved. It should be required to be grounded for the same reasons the 208Y/120-volt and 480Y/277-volt systems are presently required to be grounded. This change will facilitate introduction of this wiring system into the United States.

5.  This Proposal is original material.  
 This Proposal is not original material; its source (if known) is as follows: \_\_\_\_\_

(Note: Original material is considered to be the submitter's own idea based on or as a result of his own experience, thought, or research and, in the best of his knowledge, is not copied from another source.)

I agree to give NFPA all and full rights, including rights of copyright, in this Proposal and I understand that I acquire no rights in any publication of NFPA in which this Proposal in this or another similar or analogous form is used.

John Doe  
Signature

PLEASE USE SEPARATE FORM FOR EACH PROPOSAL

## Contents

ARTICLE	PAGE	ARTICLE	PAGE
90	1		
Introduction			
<b>Chapter 1. General</b>			
100	5		
Definitions			
Part A. General			
	5		
Part B. Over 600 Volts,			
Nominal			
	16		
110	18		
Requirements for Electrical			
Installations			
	18		
Part A. General			
	18		
Part B. Over 600 Volts,			
Nominal			
	23		
<b>Chapter 2. Wiring Design and Protection</b>			
200	27		
Use and Identification of			
Grounded Conductors			
	27		
210	30		
Branch Circuits			
Part A. General Provisions			
	30		
Part B. Branch-Circuit Rat-			
ings			
	35		
Part C. Required Outlets			
	38		
215	41		
Feeders			
220	43		
Branch-Circuit and Feeder Cal-			
culations			
	43		
Part A. General			
	43		
Part B. Feeders			
	46		
Part C. Optional Calculations			
for Computing Feeder and			
Service Loads			
	52		
Part D. Method for Comput-			
ing Farm Loads			
	55		
225	56		
Outside Branch Circuits and			
Feeders			
	56		
230	61		
Services			
Part A. General			
	61		
Part B. Overhead Service-			
Drop Conductors			
	64		
Part C. Underground			
Service-Lateral Conduc-			
tors			
	66		
Part D. Service-Entrance			
Conductors			
	66		
Part E. Service Equipment			
— General			
	70		
Part F. Service Equipment			
— Disconnecting Means			
	70		
Part G. Service Equipment			
— Overcurrent Protection			
	74		
Part H. Services Exceeding			
600 Volts, Nominal			
	76		
240	80		
Overcurrent Protection			
Part A. General			
	80		
Part B. Location			
	83		
Part C. Enclosures			
	86		
Part D. Disconnecting and			
Guarding			
	87		
		Part E. Plug Fuses,	
		Fuseholders, and Adapters	87
		Part F. Cartridge Fuses and	
		Fuseholders	88
		Part G. Circuit Breakers	89
		Part H. Overcurrent Protec-	
		tion Over 600 Volts, Nom-	
		inal	90
250	90		
Grounding			
Part A. General			
	90		
Part B. Circuit and System			
Grounding			
	93		
Part C. Location of System			
Grounding Connections			
	95		
Part D. Enclosure Grounding			
	99		
Part E. Equipment Ground-			
ing			
	100		
Part F. Methods of Ground-			
ing			
	102		
Part G. Bonding			
	106		
Part H. Grounding Electrode			
System			
	110		
Part J. Grounding Conduc-			
tors			
	112		
Part K. Grounding Conduc-			
tor Connections			
	117		
Part L. Instrument Trans-			
formers, Relays, etc.			
	118		
Part M. Grounding of Sys-			
tems and Circuits of 1 kV			
and Over (High Voltage)			
	119		
280	121		
Surge Arresters			
Part A. General			
	121		
Part B. Installation			
	121		
Part C. Connecting Surge			
Arresters			
	122		
<b>Chapter 3. Wiring Methods and Materials</b>			
300	125		
Wiring Methods			
Part A. General			
Requirements			
	125		
Part B. Requirements for			
Over 600 Volts, Nominal			
	135		
305	135		
Temporary Wiring			
310	138		
Conductors for General Wiring			
318	188		
Cable Trays			
320	196		
Open Wiring on Insulators			
321	198		
Messenger Supported Wiring			
324	199		
Concealed Knob-and-Tube			
Wiring			
	199		
325	201		
Integrated Gas Spacer Cable			
Type IGS			
	201		
Part A. General			
	201		
Part B. Installation			
	201		
Part C. Construction Specifi-			
cations			
	202		

ARTICLE	PAGE	ARTICLE	PAGE
326 Medium Voltage Cable Type MV	203	Part A. Liquidtight Flexible Metal Conduit	239
328 Flat Conductor Cable Type FCC	204	Part B. Liquidtight Flexible Nonmetallic Conduit	240
Part A. General	204	352 Surface Metal Raceways and Surface Nonmetallic Race- ways	241
Part B. Installation	205	Part A. Surface Metal Race- ways	241
Part C. Construction	206	Part B. Surface Nonmetallic Raceways	242
330 Mineral-Insulated, Metal- Sheathed Cable Type MI	208	353 Multioutlet Assembly	243
Part A. General	208	354 Underfloor Raceways	244
Part B. Installation	208	356 Cellular Metal Floor Raceways	246
Part C. Construction Specifi- cations	209	Part A. Installation	246
331 Electrical Nonmetallic Tubing	209	Part B. Construction Specifi- cations	247
Part A. General	209	358 Cellular Concrete Floor Race- ways	247
Part B. Installation	210	362 Wireways	249
Part C. Construction Specifi- cations	211	363 Flat Cable Assemblies Type FC	250
333 Armored Cable Type AC	211	364 Busways	252
334 Metal-Clad Cable	213	Part A. General Requirements	252
Part A. General	213	Part B. Requirements for Over 600 Volts, Nominal	254
Part B. Installation	214	365 Cablebus	255
Part C. Construction Specifi- cations	215	370 Outlet, Device, Pull and Junc- tion Boxes, Conduit Bodies and Fittings	257
336 Nonmetallic-Sheathed Cable Types NM and NMC	216	Part A. Scope and General	257
Part A. General	216	Part B. Installation	257
Part B. Installation	216	Part C. Construction Specifi- cations	264
Part C. Construction Specifi- cations	218	Part D. Pull and Junction Boxes for Use on Systems Over 600 Volts, Nominal	265
337 Shielded Nonmetallic-Sheathed Cable Type SNM	218	373 Cabinets and Cutout Boxes	266
338 Service-Entrance Cable Types SE and USE	219	Part A. Installation	266
339 Underground Feeder and Branch-Circuit Cable Type UF	220	Part B. Construction Specifi- cations	269
340 Power and Control Tray Cable Type TC	222	374 Auxiliary Gutters	270
342 Nonmetallic Extensions	223	380 Switches	272
344 Underplaster Extensions	224	Part A. Installation	272
345 Intermediate Metal Conduit	225	Part B. Construction Specifi- cations	275
Part A. General	225	384 Switchboards and Panelboards	276
Part B. Installation	226	Part A. Switchboards	277
Part C. Construction Specifi- cations	227	Part B. Panelboards	279
346 Rigid Metal Conduit	227	Part C. Construction Specifi- cations	280
Part A. Installation	228		
Part B. Construction Specifi- cations	231		
347 Rigid Nonmetallic Conduit	231		
Part A. Installations	232		
Part B. Construction Specifi- cations	233		
348 Electrical Metallic Tubing	233		
Part A. Installation	234		
Part B. Construction Specifi- cations	235		
349 Flexible Metallic Tubing	235		
Part A. General	235		
Part B. Construction and In- stallation	236		
350 Flexible Metal Conduit	237		
351 Liquidtight Flexible Metal Con- duit and Liquidtight Flexible Nonmetallic Conduit	239		

#### Chapter 4. Equipment for General Use

400 Flexible Cords and Cables	283
Part A. General	283
Part B. Construction Specifi- cations	295
Part C. Portable Cables Over 600 Volts, Nominal	296
402 Fixture Wires	297

ARTICLE	PAGE	ARTICLE	PAGE
410 Lighting Fixtures,		426 Fixed Outdoor Electric De-	
Lampholders, Lamps, Re-		Icing and Snow-Melting	
ceptacles, and Rosettes . . . . .	304	Equipment . . . . .	344
Part A. General . . . . .	304	Part A. General . . . . .	344
Part B. Fixture Locations . . . . .	305	Part B. Installation . . . . .	345
Part C. Provisions at Fixture		Part C. Resistance Heating	
Outlet Boxes, Canopies,		Elements . . . . .	345
and Pans . . . . .	306	Part D. Impedance Heating . . . . .	347
Part D. Fixture Supports . . . . .	307	Part E. Skin Effect Heating . . . . .	348
Part E. Grounding . . . . .	308	Part F. Control and Protec-	
Part F. Wiring of Fixtures . . . . .	309	tion . . . . .	348
Part G. Construction of Fix-		427 Fixed Electric Heating Equip-	
tures . . . . .	311	ment for Pipelines and Ves-	
Part H. Installations of		sels . . . . .	349
Lampholders . . . . .	313	Part A. General . . . . .	349
Part J. Construction of		Part B. Installation . . . . .	350
Lampholders . . . . .	313	Part C. Resistance Heating	
Part K. Lamps and Auxiliary		Elements . . . . .	351
Equipment . . . . .	314	Part D. Impedance Heating . . . . .	352
Part L. Receptacles, Cord		Part E. Induction Heating . . . . .	352
Connectors, and Attach-		Part F. Skin Effect Heating . . . . .	353
ment Plugs (Caps) . . . . .	314	Part G. Control and Protec-	
Part M. Rosettes . . . . .	316	tion . . . . .	353
Part N. Special Provisions		430 Motors, Motor Circuits, and	
for Flush and Recessed		Controllers . . . . .	354
Fixtures . . . . .	317	Part A. General . . . . .	354
Part P. Construction of Flush		Part B. Motor Circuit Con-	
and Recessed Fixtures . . . . .	318	ductors . . . . .	363
Part Q. Special Provisions		Part C. Motor and Branch-	
for Electric-Discharge		Circuit Overload Protec-	
Lighting Systems of 1000		tion . . . . .	367
Volts or Less . . . . .	318	Part D. Motor Branch-Cir-	
Part R. Special Provisions		cuit Short-Circuit and	
for Electric-Discharge		Ground-Fault Protection . . . . .	372
Lighting Systems of More		Part E. Motor Feeder Short-	
than 1000 Volts . . . . .	320	Circuit and Ground-Fault	
Part S. Lighting Track . . . . .	321	Protection . . . . .	375
422 Appliances . . . . .	322	Part F. Motor Control Cir-	
Part A. General . . . . .	322	cuits . . . . .	376
Part B. Branch-Circuit Re-		Part G. Motor Controllers . . . . .	379
quirements . . . . .	323	Part H. Disconnecting Means	
Part C. Installation of Appli-		Part J. Over 600 Volts, Nom-	
ances . . . . .	323	inal . . . . .	385
Part D. Control and Protec-		Part K. Protection of Live	
tion of Appliances . . . . .	326	Parts — All Voltages . . . . .	386
Part E. Marking of Appli-		Part L. Grounding All Volt-	
ances . . . . .	329	ages . . . . .	387
424 Fixed Electric Space Heating		Part M. Tables . . . . .	388
Equipment . . . . .	330	440 Air-Conditioning and Refriger-	
Part A. General . . . . .	330	ating Equipment . . . . .	394
Part B. Installation . . . . .	330	Part A. General . . . . .	394
Part C. Control and Protec-		Part B. Disconnecting Means . . . . .	397
tion of Fixed Electric		Part C. Branch-Circuit Short-	
Space Heating Equipment . . . . .	331	Circuit and Ground-Fault	
Part D. Marking of Heating		Protection . . . . .	398
Equipment . . . . .	334	Part D. Branch-Circuit Con-	
Part E. Electric Space Heat-		ductors . . . . .	400
ing Cables . . . . .	334	Part E. Controllers for	
Part F. Duct Heaters . . . . .	337	Motor-Compressors . . . . .	401
Part G. Resistance-type Boil-		Part F. Motor-Compressor	
ers . . . . .	338	and Branch-Circuit Over-	
Part H. Electrode-type Boil-		load Protection . . . . .	401
ers . . . . .	340	Part G. Provisions for Room	
Part J. Electric Radiant		Air Conditioners . . . . .	403
Heating Panels and Heat-		445 Generators . . . . .	404
ing Panel Sets . . . . .	341		

ARTICLE	PAGE	ARTICLE	PAGE
450 Transformers and Transformer Vaults (Including Secondary Ties) . . . . .	406	Part D. Portable-Switchboards on Stage . . . . .	512
Part A. General Provisions . . . . .	406	Part E. Stage Equipment — Portable . . . . .	515
Part B. Specific Provisions Applicable to Different Types of Transformers . . . . .	413	Part F. Dressing Rooms . . . . .	517
Part C. Transformer Vaults . . . . .	415	Part G. Grounding . . . . .	517
460 Capacitors . . . . .	417	530 Motion Picture and Television Studios and Similar Locations . . . . .	517
Part A. 600 Volts, Nominal, and Under . . . . .	417	Part A. General . . . . .	517
Part B. Over 600 Volts, Nominal . . . . .	418	Part B. Stage or Set . . . . .	517
470 Resistors and Reactors . . . . .	420	Part C. Dressing Rooms . . . . .	520
Part A. 600 Volts, Nominal, and Under . . . . .	420	Part D. Viewing, Cutting, and Patching Tables . . . . .	520
Part B. Over 600 Volts, Nominal . . . . .	420	Part E. Cellulose Nitrate Film Storage Vaults . . . . .	520
480 Storage Batteries . . . . .	421	Part F. Substations . . . . .	520
<b>Chapter 5. Special Occupancies</b>			
500 Hazardous (Classified) Locations . . . . .	423	540 Motion Picture Projectors . . . . .	521
501 Class I Locations . . . . .	430	Part A. General . . . . .	521
502 Class II Locations . . . . .	441	Part B. Definitions . . . . .	521
503 Class III Locations . . . . .	449	Part C. Equipment and Projectors of the Professional Type . . . . .	521
510 Hazardous (Classified) Locations — Specific . . . . .	453	Part D. Nonprofessional Projectors . . . . .	523
511 Commercial Garages, Repair and Storage . . . . .	453	Part E. Sound Recording and Reproduction . . . . .	523
513 Aircraft Hangars . . . . .	456	545 Manufactured Building . . . . .	523
514 Gasoline Dispensing and Service Stations . . . . .	459	Part A. General . . . . .	523
515 Bulk Storage Plants . . . . .	463	547 Agricultural Buildings . . . . .	525
516 Spray Application, Dipping and Coating Processes . . . . .	467	550 Mobile Homes and Mobile Home Parks . . . . .	527
517 Health Care Facilities . . . . .	476	Part A. Mobile Homes . . . . .	528
Part A. General . . . . .	476	Part B. Mobile Home Parks . . . . .	539
Part B. Wiring Systems — General . . . . .	479	551 Recreational Vehicles and Recreational Vehicle Parks . . . . .	541
Part C. Clinics, Medical and Dental Offices, Outpatient Facilities, and Other Health Care Facilities Not Covered in Parts D and E . . . . .	480	Part A. Recreational Vehicles . . . . .	542
Part D. Nursing Homes and Residential Custodial Care Facilities . . . . .	481	Part B. Recreational Vehicle Parks . . . . .	559
Part E. Hospitals . . . . .	487	553 Floating Buildings . . . . .	562
Part F. Patient Care Areas . . . . .	495	Part A. General . . . . .	562
Part G. Inhalation Anesthetizing Locations . . . . .	498	Part B. Services and Feeders . . . . .	563
Part H. Communications, Signaling Systems; Data Systems, Fire Protective Signaling Systems, and Low-Voltage Systems . . . . .	504	Part C. Grounding . . . . .	563
Part K. X-ray Installations . . . . .	504	555 Marinas and Boatyards . . . . .	564
518 Places of Assembly . . . . .	506	<b>Chapter 6. Special Equipment</b>	
520 Theaters and Similar Locations . . . . .	508	600 Electric Signs and Outline Lighting . . . . .	567
Part A. General . . . . .	508	Part A. General . . . . .	567
Part B. Fixed Stage Switchboard . . . . .	508	Part B. 600 Volts, Nominal, or Less . . . . .	569
Part C. Stage Equipment — Fixed . . . . .	510	Part C. Over 600 Volts, Nominal . . . . .	570
		604 Manufactured Wiring Systems . . . . .	574
		605 Office Furnishings . . . . .	575
		610 Cranes and Hoists . . . . .	577
		Part A. General . . . . .	577
		Part B. Wiring . . . . .	577
		Part C. Contact Conductors . . . . .	581
		Part D. Disconnecting Means . . . . .	582
		Part E. Overcurrent Protection . . . . .	583
		Part F. Control . . . . .	584

ARTICLE	PAGE	ARTICLE	PAGE
620 Part G. Grounding	.584	Part G. Hydromassage Bath-	
Elevators, Dumbwaiters, Escalators, and Moving Walks	.585	tubs	.634
Part A. General	.585	685 Integrated Electrical Systems	.634
Part B. Conductors	.585	Part A. General	.634
Part C. Wiring	.587	Part B. Orderly Shutdown	.635
Part D. Installation of Conductors	.588	690 Solar Photovoltaic Systems	.635
Part E. Traveling Cables	.589	Part A. General	.635
Part F. Disconnecting Means and Control	.589	Part B. Circuit Requirements	.637
Part G. Overcurrent Protection	.590	Part C. Disconnecting Means	.639
Part H. Machine Room	.591	Part D. Wiring Methods	.639
Part J. Grounding	.592	Part E. Grounding	.640
Part K. Overspeed	.592	Part F. Marking	.641
630 Electric Welders	.593	Part G. Connection to Other Sources	.641
Part A. General	.593	Part H. Storage Batteries	.642
Part B. AC Transformer and DC Rectifier Arc Welders	.593		
Part C. Motor-Generator Arc Welders	.594		
Part D. Resistance Welders	.595		
Part E. Welding Cable	.596		
640 Sound-Recording and Similar Equipment	.597		
645 Electronic Computer/Data Processing Equipment	.599		
650 Organs	.600		
660 X-ray Equipment	.601		
Part A. General	.601		
Part B. Control	.603		
Part C. Transformers and Capacitors	.604		
Part D. Guarding and Grounding	.604		
665 Induction and Dielectric Heating Equipment	.604		
Part A. General	.604		
Part B. Guarding, Grounding, and Labeling	.605		
Part C. Motor-Generator Equipment	.606		
Part D. Equipment Other than Motor-Generator	.607		
668 Electrolytic Cells	.609		
669 Electroplating	.613		
670 Industrial Machinery	.614		
675 Electrically Driven or Controlled Irrigation Machines	.615		
Part A. General	.615		
Part B. Center Pivot-Irrigation Machines	.618		
680 Swimming Pools, Fountains and Similar Installations	.619		
Part A. General	.619		
Part B. Permanently Installed Pools	.623		
Part C. Storable Pools	.629		
Part D. Spas and Hot Tubs	.629		
Part E. Fountains	.631		
Part F. Therapeutic Pools and Tubs in Health Care Facilities	.633		
		<b>Chapter 7. Special Conditions</b>	
		700 Emergency Systems	.645
		Part A. General	.645
		Part B. Circuit Wiring	.647
		Part C. Sources of Power	.647
		Part D. Emergency System Circuits for Lighting and Power	.649
		Part E. Control — Emergency Lighting Circuits	.650
		Part F. Overcurrent Protection	.650
		701 Legally Required Standby Systems	.651
		Part A. General	.651
		Part B. Circuit Wiring	.652
		Part C. Sources of Power	.652
		Part D. Overcurrent Protection	.654
		702 Optional Standby Systems	.655
		Part A. General	.655
		Part B. Circuit Wiring	.655
		705 Interconnected Electric Power Production Sources	.656
		710 Over 600 Volts, Nominal — General	.658
		Part A. General	.658
		Part B. Equipment — General Provisions	.661
		Part C. Equipment — Specific Provisions	.661
		Part D. Installations Accessible to Qualified Persons Only	.667
		Part E. Mobile and Portable Equipment	.669
		Part F. Tunnel Installations	.670
		Part G. Electrode-type Boilers	.671
		720 Circuits and Equipment Operating at less than 50 Volts	.672
		725 Class 1, Class 2, and Class 3 Remote-Control, Signaling, and Power-Limited Circuits	.672
		Part A. Scope and General	.672
		Part B. Class 1 Circuits	.674
		Part C. Class 2 and Class 3 Circuits	.676



ARTICLE	PAGE	ARTICLE	PAGE
760 Fire Protective Signaling Systems . . . . .	.683	Table 4. Dimensions and Percent Area of Conduit and of Tubing . . . . .	.722
Part A. Scope and General	.683	Table 5. Dimensions of Rubber-Covered and Thermoplastic-Covered Conductors . . . . .	.723
Part B. Nonpower-Limited Fire Protective Signaling Circuits . . . . .	.684	Table 5A. Aluminum Building Wire Nominal Dimensions and Areas . . . . .	.725
Part C. Power-Limited Fire Protective Signaling Circuits . . . . .	.686	Table 6. Dimensions of Lead-Covered Conductors . . . . .	.726
770 Optical Fiber Cables . . . . .	.692	Table 7. Dimensions of Asbestos-Varnished-Cambric Insulated Conductors . . . . .	.727
780 Closed-Loop and Programmed Power Distribution . . . . .	.695	Table 8. Conductor Properties . . . . .	.728
		Table 9. AC Resistance and Reactance . . . . .	.729
<b>Chapter 8. Communication Systems</b>		Part B. Examples . . . . .	.730
800 Communication Circuits . . . . .	.697	Example No. 1(a). One-Family Dwelling . . . . .	.730
Part A. General . . . . .	.697	Example No. 1(b). One-Family Dwelling . . . . .	.731
Part B. Protection . . . . .	.697	Example No. 2(a). Optional Calculation for One-Family Dwelling Heating Larger than Air Conditioning . . . . .	.731
Part C. Outside Conductors	.701	Example No. 2(b). Optional Calculation for One-Family Dwelling Air Conditioning Larger than Heating . . . . .	.732
Part D. Underground Circuits . . . . .	.703	Example No. 3. Store Building . . . . .	.733
Part E. Grounding . . . . .	.703	Example No. 4(a). Multifamily Dwelling . . . . .	.734
810 Radio and Television Equipment . . . . .	.704	Example No. 4(b). Optional Calculation for Multifamily Dwelling . . . . .	.736
Part A. General . . . . .	.704	Example No. 5(a). Multifamily Dwelling Served at 208Y/120 Volts, Three Phase . . . . .	.738
Part B. Receiving Equipment — Antenna Systems . . . . .	.705	Example No. 5(b). Optional Calculation for Multifamily Dwelling Served at 208Y/120 Volts, Three Phase . . . . .	.739
Part C. Amateur Transmitting and Receiving Stations — Antenna Systems . . . . .	.708	Example No. 6. Maximum Demand for Range Loads . . . . .	.739
Part D. Interior Installation — Transmitting Stations . . . . .	.709	Example No. 8. Motors, Conductors, Overload, and Short-Circuit and Ground-Fault Protection . . . . .	.740
820 Community Antenna Television and Radio Distribution Systems . . . . .	.710	Appendix A . . . . .	.741
Part A. General . . . . .	.710	Index . . . . .	.743
Part B. Protection . . . . .	.710		
Part C. Installation of Cable	.711		
Part D. Underground Circuits . . . . .	.714		
Part E. Grounding . . . . .	.714		
<b>Chapter 9. Tables and Examples</b>			
Part A. Tables . . . . .	.717		
Table 1. Percent of Cross Section of Conduit and Tubing for Conductors . . . . .	.717		
Table 2. Maximum Number of Fixture Wires in Trade Sizes of Conduit or Tubing . . . . .	.718		
Tables 3A, 3B and 3C. Maximum Number of Conductors in Trade Sizes of Conduit or Tubing . . . . .	.719-721		

# NATIONAL ELECTRICAL CODE COMMITTEE

## Correlating Committee

**R. G. Biermann**, *Chairman*  
Des Moines, IA

**Peter J. Schram**, *Secretary*  
National Fire Protection Association  
(Nonvoting)

**Shirley N. Irving**, *Acting Recording Secretary*  
National Fire Protection Association  
(Nonvoting)

**M. F. Borleis**, Baltimore, MD  
**William R. Drake**, Northbrook, IL  
**Joseph E. Pipkin**, Washington, DC  
**Earl W. Roberts**, Plainville, CT  
**Charles B. Schram**, Northbrook, IL  
(Liaison to NFPA Committee on Air Condition-  
ing)  
**Len H. Sessler**, Morristown, NJ  
**James C. Sharp**, Washington, DC  
**Jay A. Stewart**, Freeport, NY  
**Wilford I. Summers**, Park Ridge, IL

### Alternates

**Edward L. Eldridge**, Raritan, NJ  
(Alternate to E. W. Roberts)  
**Theodore F. Moseley**, Washington, DC  
(Alternate to J. C. Sharp)  
**Richard W. Osborn**, St. Louis, MO  
(Alternate to R. G. Biermann)  
**John W. Troglia**, Milwaukee, WI  
(Alternate to M. F. Borleis)

## PANEL NO. 1 — Articles 90, 100, 110

**William F. Born**, *Chairman*  
Westinghouse Electric Corp.  
(Rep. Nat'l Electrical Manufacturers Assn.)

**M. F. Borleis**, Baltimore Gas & Electric  
(Rep. Electric Light & Power Group)  
**Charles J. Hart**, Nat'l Electrical Contractors Assn.  
**Vincent J. Hession**, Bell Communications Research  
Inc.  
(Rep. Exchange Carriers Standards Assn.)  
**Ed Palko**, Plant Engineering Magazine  
(Rep. Inst. of Electrical & Electronics  
Engineers)  
**Robert W. Seelbach**, Underwriters Laboratories  
Inc.  
**Wilford I. Summers**, Assn. of Electrical Inspectors  
**Robert Vining**, Int'l Brotherhood of Electrical  
Workers, Local 415  
**Donald A. Voltz**, Dow Chemical USA  
(Rep. Chemical Manufacturers Assn.)

### Alternates

**Harold D. Adelman**, Southern California Edison  
(Alternate to M. F. Borleis)  
**H. Lee Bray**, USDA - US Forest Service  
(Alternate to W. I. Summers)  
**Franklin P. Gertson**, Texas Eastern Transmission  
Corp.  
(Alternate to E. Palko)  
**F. K. Kitzantides**, Nat'l Electrical Manufacturers  
Assn.  
(Alternate to W. F. Born)  
**Reginald McMurdo**, Int'l Brotherhood of Electrical  
Workers, Local 768  
(Alternate to R. Vining)  
**Steven G. Roll**, Underwriters Laboratories Inc.  
(Alternate to R. W. Seelbach)

### Nonvoting

**John Caicco**, Canadian General Electric Co., Ltd.

## PANEL NO. 2 — Articles 210, 215, 220, Chapter 9 Examples No. 1 through No. 6

**Earl W. Roberts**, *Chairman*  
General Electric Co.  
(Rep. Nat'l Electrical Manufacturers Assn.)

**Frank M. Bowling**, Rockvale, TN  
(Rep. Int'l Assn. of Electrical Inspectors)  
**Robert J. Cunningham**, Duquesne Light Co.  
(Rep. Electric Light & Power Group)  
**Charles W. Fisher**, Int'l Brotherhood of Electrical  
Workers, Local 25  
**Thomas L. Harman**, Univ. of Houston - Clear Lake  
**Gilbert G. Hazzard**, Independent Electrical Con-  
t. Inc.  
**Jack W. Hogg**, Underwriters Laboratories Inc.

**Anthony C. Lordi**, Bendy Engineering Co.  
(Rep. Inst. of Electrical & Electronics  
Engineers)  
**Joseph W. Rao**, R. A. O. Electric Co.  
(Rep. Nat'l Electrical Contractors Assn.)  
**William H. Reign**, Hercules Inc.  
(Rep. Chemical Manufacturers Assn.)  
**Bryan W. Vaughan**, Baum Electric Co.  
(Rep. Nat'l Assn. of Home Builders)

**Alternates**

**J. F. Abegglen**, San Diego Gas & Electric  
(Alternate to R. J. Cunningham)  
**George F. Hawkes**, Crouse-Hinds Co.  
(Alternate to E. W. Roberts)  
**Thomas John**, Lanor Electric & Air-Conditioning Co.  
(Alternate to G. G. Hazzard)

**Allen F. Knickrehm**, The Knickrehm Co.  
(Alternate to J. W. Rao)  
**George R. McKinnon**, Jefferson County Commission, AL  
(Alternate to F. M. Bowling)  
**Thomas E. Sparling**, Sparling & Assoc. Inc.  
(Alternate to A. C. Lordi)  
**William Wusinich**, Int'l Brotherhood of Electrical Workers, Local 98  
(Alternate to C. W. Fisher)

**PANEL NO. 3 — Articles 300, 305, 690**

**E. C. Lawry**, *Chairman*  
Wisconsin Dept. Industrial Labor & Human Relations  
(Rep. Int'l Assn. of Electrical Inspectors)

**Harold D. Adelman**, Southern California Edison Co.  
(Rep. Electric Light & Power Group)  
**Jonah Eidelberg**, Efcor Inc.  
(Rep. Nat'l Electrical Manufacturers Assn.)  
**Donald A. Mader**, Underwriters Laboratories Inc.  
**Gene H. Mottern**, Tennessee Eastman Co.  
(Rep. Chemical Manufacturers Assn.)  
**Howard Schier**, Int'l Brotherhood of Electrical Workers, Local 164  
**Bernard W. Whittington**, Whittington Engineering Co.  
(Rep. Inst. of Electrical & Electronics Engineers)  
**Thomas H. Wood**, Cecil B. Wood Inc.  
(Rep. Nat'l Electrical Contractors Assn.)

**Alternates**

**Charles R. Bartholf**, Underwriters Laboratories Inc.  
(Alternate to D. A. Mader)  
**D. B. Berry**, Texas Electric Service Co.  
(Alternate to H. D. Adelman)  
**Richard G. Gewain**, American Iron and Steel Inst.  
(Alternate to American Iron & Steel Ins. Rep.)  
**M. J. Hendricks**, Union Carbide Corp.  
(Alternate to B. W. Whittington)  
**Charles E. Jackson**, Celanese Chemical Co., Inc.  
(Alternate to G. H. Mottern)  
**George A. Straniero**, Triangle PWC, Inc.  
(Alternate to J. Eidelberg)  
**Raymond Thompson**, Int'l Brotherhood of Electrical Workers, Local 5  
(Alternate to H. Schier)  
**Raymond W. Weber**, City of Wisconsin Rapids, WI  
(Alternate to E. C. Lawry)

**PANEL NO. 4 — Articles 225, 230, 240, 780**

**Glen W. Cock**, *Chairman*  
Tampa Electric Co.  
(Rep. Electric Light & Power Group)

**William A. Anderson, Jr.**, City of Bellevue, WA  
(Rep. Int'l Assn. of Electrical Inspectors)  
**K. W. Carrick**, Union Carbide Corp.  
(Rep. Inst. of Electrical & Electronics Engineers)  
**Robert T. Davis, Jr.**, Knoxville Utilities Board  
(Rep. American Public Power Assn.)  
**Robert C. Edwards**, Armo Inc.  
(Rep. Assn. of Iron & Steel Engineers)  
**Donald G. Fischer**, Square D Co.  
(Rep. Nat'l Electrical Manufacturers Assn.)  
**Paul P. Gubany**, Bussman Mfg. Div., McGraw-Edison Co.  
**Patrick R. Herbert**, High Voltage Maintenance Corp.  
(Rep. Nat'l Electrical Testing Assn.)  
**James Lee Hunter**, Southwire Co.  
(Rep. The Aluminum Assn.)  
**Norbert J. Izydorek**, Underwriters Laboratories Inc.  
**Dimitrios M. Karydas**, Factory Mutual Research  
**John H. Kassebaum**, Eli Lilly & Co.  
(Rep. Chemical Manufacturers Assn.)  
**William A. Muska**, Muska Electric Co.  
(Rep. Nat'l Electrical Contractors Assn.)  
**Albert J. Reed**, New York Board of Fire Underwriters  
**William J. Rothert**, Int'l Brotherhood of Electrical Workers, Local 212  
**Ben Z. Segall**, New Orleans, LA

**Leonard K. VanTassel**, Carrier Air Conditioning Co.  
(Rep. Air-Conditioning & Refrigeration Inst.)

**Alternates**

**Robert J. Deaton**, Union Carbide Corp.  
(Alternate to K. W. Carrick)  
**John F. Derricott**, Pennwalt Corp.  
(Alternate to J. H. Kassebaum)  
**Dale Fickling**, Int'l Brotherhood of Electrical Workers, Local 898  
(Alternate to W. J. Rothert)  
**Bobby C. Gentry**, Southwire Co.  
(Alternate to J. L. Hunter)  
**Dean H. Klohr**, Bussman Mfg. Div., McGraw-Edison Co.  
(Alternate to P. P. Gubany)  
**James W. Patterson**, Philadelphia Electric Co.  
(Alternate to G. W. Cock)  
**Herbert C. Skarbeck**, Air-Conditioning & Refrigeration Inst.  
(Alternate to L. K. VanTassel)  
**John H. Stricklin**, Mt. Home, ID  
(Alternate to W. A. Anderson, Jr.)  
**R. O. D. Whitt**, Westinghouse Electric Corp.  
(Alternate to D. G. Fischer)

**Nonvoting**

**M. R. Holman**, Square D Co., Canada

## PANEL NO. 5 — Articles 200, 250, 280

**Len H. Sessler, Chairman**  
Bell Communications Research  
(Rep. Exchange Carriers Standards Assn.)

**J. L. Bennett**, Black & Decker Co.  
(Rep. Power Tool Institute)  
**Edward J. Cohen**, US Dept. of Agriculture.  
Rural Electrification Administration  
**William R. Drake**, Daniel Woodhead Co.  
(Rep. Nat'l Safety Council)  
**Edward L. Eldridge**, Thomas & Betts Corp.  
(Rep. Nat'l Electrical Manufacturers Assn.)  
**Gary Gilbert**, Int'l Brotherhood of Electrical Workers, Local 231  
**Donald H. McIntosh**, Newark, DE  
(Rep. Chemical Manufacturers Assn.)  
**Leo Nagel**, ND State Electrical Board  
(Rep. Int'l Assn. of Electrical Inspectors)  
**W. J. Neiswender**, AT&T Technologies, Inc.  
(Rep. Inst. of Electrical & Electronics Engineers)  
**C. L. Pittman**, Maryville, TN  
(Rep. The Aluminum Association)  
**V. A. Sechler**, American Electric Power Service Corp.  
(Rep. Electric Light & Power Group)  
**Walter Skuggevig**, Underwriters Laboratories Inc.  
**Ronald J. Toomer**, Toomer Electrical Co., Inc.  
(Rep. Nat'l. Electrical Contractors Assn.)

## Alternates

**Harvey L. Bowles**, US Dept. of Agriculture.  
Rural Electrification Administration  
(Alternate to E. J. Cohen)

**Norman H. Davis III**, Underwriters Laboratories Inc.  
(Alternate to W. Skuggevig)  
**James M. Ferron**, Independent Electrical Insp. Agency  
(Alternate to W. Drake)  
**Donald J. Frost**, Int'l Brotherhood of Electrical Workers, Local 288  
(Alternate to G. Gilbert)  
**Richard A. Haman**, ND State Electrical Board  
(Alternate to L. Nagel)  
**Chester H. Lake**, E. I. du Pont de Nemours & Co.  
(Alternate to D. H. McIntosh)  
**James H. Layne**, Reynolds Metals Co.  
(Alternate to C. L. Pittman)  
**Mel H. Neuhardt**, Robert Bosch' Power Tool Corp.  
(Alternate to J. L. Bennett)  
**Elliott Rappaport**, Electro Technology Consultants, Inc.  
(Alternate to W. J. Neiswender)  
**Jerome W. Seigel**, General Electric Co.  
(Alternate to E. Eldridge)  
**Ronald K. Smith**, Houston Lighting & Power Co.  
(Alternate to V. A. Sechler)

## Nonvoting

**K. N. Fennessey**, Dept. of Labour Edmonton, Alberta, Canada

PANEL NO. 6 — Articles 310, 400, 402, Chapter 9  
Tables 5 through 9

**John E. Lipsey, Chairman**  
Gulfport, MS  
(Rep. Electric Light & Power Group)

**William C. Berry**, Int'l Brotherhood of Electrical Workers, Local 317  
**Edward J. Coffey**, Underwriters Laboratories Inc.  
**John E. Conley**, Stamford, CT.  
(Rep. Nat'l Electrical Manufacturers Assn.)  
**P. H. Cox, Jr.**, Arkansas Dept. of Labor  
(Rep. Int'l Assn. of Electrical Inspectors)  
**Dwight Durham**, Southwire Co.  
(Rep. The Aluminum Association)  
**James W. Frasure**, Dow Chemical USA  
(Rep. Chemical Manufacturers Assn.)  
**A. F. KnickKrehm**, The KnickKrehm Co.  
(Rep. Nat'l Electrical Contractors Assn.)  
**L. Bruce McClung**, Union Carbide Corp.  
(Rep. Inst. of Electrical & Electronics Engineers)  
**Ben Z. Segall**, New Orleans, LA

## Alternates

**David P. Brown**, Baltimore Gas & Electric Co.  
(Alternate to J. E. Lipsey)  
**Stanley Kahn**, Eastern States-Kahn Electric  
(Alternate to A. F. KnickKrehm)  
**Roger S. Keith**, Barrington, RI  
(Alternate to D. Durham)  
**J. S. Prifogge**, Cooper Industries  
(Alternate to J. E. Conley)  
**Robert R. Sallaz**, City of Akron, OH  
(Alternate to P. H. Cox, Jr.)  
**Steven L. Stump**, Int'l Brotherhood of Electrical Workers, Local 1340  
(Alternate to W. C. Berry)  
**Austin D. Wetherell**, Underwriters Laboratories Inc.  
(Alternate to E. J. Coffey)

## Nonvoting

**J. G. C. Henderson**, Canada Wire & Cable Ltd.

**PANEL NO. 7 — Articles 320, 321, 324, 325, 326,  
328, 330, 333, 334, 336, 337, 338, 339,  
340, 342, 344, 363**

**Constantine S. Golovko, Chairman**  
LA County Bldg. & Safety Div.  
(Rep. International Assn. of Electrical Inspectors)

**W. O. Andersen, Jr., Kaiser Aluminum & Chemical Corp.**

(Rep. The Aluminum Association)  
**James W. Barthman, City of Oakland, CA**  
(Rep. Int'l Conference of Building Officials)

**Thomas J. Guida, Underwriters Laboratories Inc.**  
**A. P. Haggerty, Scott Paper Co.**  
(Rep. Inst. of Electrical & Electronics Engineers)

**Charles J. Hart, Nat'l Electrical Contractors Assn.**  
**Russell W. Higginbottom, Triangle Conduit & Cable Co.**

(Rep. Nat'l Electrical Manufacturers Assn.)  
**John A. Kroiss, Shell Oil Co.**

(Rep. Chemical Manufacturers Assn.)  
**Frank D. Moore, Livingston, AL**

(Rep. Int'l Brotherhood of Electrical Workers)  
**David C. Roberts, American Electric Power Service Corp.**

(Rep. Electric Light & Power Group)

**Alternates**

**W. H. Chambers, Kern County, CA**  
(Alternate to C. S. Golovko)

**Edward J. Coffey, Underwriters Laboratories Inc.**  
(Alternate to T. J. Guida)

**Bobby C. Gentry, Southwire Co.**  
(Alternate to W. O. Andersen, Jr.)

**J. Dale Hampton, Oklahoma Gas & Electric Co.**  
(Alternate to D. C. Roberts)

**Ralph H. Lee, Lee Electrical Engineering, Inc.**  
(Alternate to A. P. Haggerty)

**John V. Lipe, ITT Royal Electric Division**  
(Alternate to R. W. Higginbottom)

**James Mullinax, Jr., IBEW Local 136**  
(Alternate to F. D. Moore)

**D. F. Tulloch, Union Carbide Corp.**  
(Alternate to J. A. Kroiss)

**Bryan W. Vaughan, Baum Electric Co.**  
(Alternate to National Home Builders Rep.)

**PANEL NO. 8 — Articles 318, 331, 345, 346,  
347, 348, 349, 350, 351, 352, 353, 354,  
356, 358, 362, 364, 365, 374,  
Chapter 9 Tables 1 through 4**

**Armond C. Webb, Chairman**  
Pacific Gas & Electric Co.  
(Rep. Electric Light & Power Group)

**Charles R. Barthoff, Underwriters Laboratories Inc.**

**Dwight Durham, Southwire Co.**  
(Rep. The Aluminum Association)

**Mark W. Earley, Factory Mutual Research Corp.**  
**J. Earl Kreuzer, Electric Products Division, Midland-Ross Corp.**

(Rep. Nat'l Electrical Manufacturers Assn.)

**Samuel S. Levinrad, US Veterans Administration**

**Richard E. Long, Union Carbide Corp.**  
(Rep. Inst. of Electrical & Electronics Engineers)

**Milton Lounsbury, New York Board of Fire Underwriters**

**Ray O'Leary, O'Leary Electric Inc.**  
(Rep. Nat'l Electrical Contractors Assn.)

**Roger L. Sandstedt, Monsanto Co.**  
(Rep. Chemical Manufacturers Assn.)

**John T. Thoenke, Int'l Brotherhood of Electrical Workers, Seniority Board**

**M. L. Young, Springfield, VA**  
(Rep. Int'l Assn. of Electrical Inspectors)

**Alternates**

**Robert P. Bohn, Wisconsin Power & Light Co.**  
(Alternate to A. C. Webb)

**W. M. Griffith, Charlotte-Mecklenburg Bldg. Stds., NC**

(Alternate to M. L. Young)

**Roger S. Keith, Barrington, RI**

(Alternate to D. Durham)

**Ronald C. Muckway, Int'l Brotherhood of Electrical Workers, Local 531**

(Alternate to J. T. Thoenke)

**Robert B. Phillips, Monsanto Co.**

(Alternate to R. L. Sandstedt)

**Richard Troth, VA Office of Construction**

(Alternate to S. S. Levinrad)

**L. Vincent, I-T-E Elec. Prod. Div. of Siemens-Allis, Inc.**

(Alternate to J. E. Kreuzer)

**Nonvoting**

**G. W. Brand, City Hall, Vancouver, BC, Canada**

**PANEL NO. 9 — Articles 370, 373, 380, 384**

**Dale R. Deming, Acting Chairman**  
Midland-Ross Corp.

**Artie O. Barker, Boise, ID**  
**Raymond J. Burniston, Thomas & Betts**  
(Rep. Nat'l Electrical Manufacturers Assn.)

**Clyde H. Craig, Craig Electric Co.**

(Rep. Nat'l Electrical Contractors Assn.)

**Ray W. Eckardt, Underwriters Laboratories Inc.**

**Daniel P. LaMorte, AT&T Resource Management Co.**

(Rep. Inst. of Electrical & Electronics Engineers)

**Anthony J. Mussi, New York Board of Fire Underwriters**

(Rep. Int'l Assn. of Electrical Inspectors)

**Fred J. Smith**, Int'l Brotherhood of Electrical Workers, Local 117

**Max E. Treece**, Duke Power Co.  
(Rep. Electric Light & Power Group)

**Alternates**

**Joseph A. Cannatelli**, ARCO Chem. Co.  
(Alternate to CMA Rep.)

**Michael J. Faser**, Underwriters Laboratories Inc.  
(Alternate to R. W. Eckardt)

**Jerome E. Holding**, Int'l Brotherhood of Electrical Workers, Local 430  
(Alternate to F. J. Smith)

**Philip L. Johnson**, I-T-E Electrical Products  
(Alternate to R. J. Burniston)

**Paul E. Kaup**, Bell of Pennsylvania  
(Alternate to D. P. LaMorte)

**William R. Stalker**, Commonwealth Edison Co.  
(Alternate to M. E. Treece)

**Jeffrey L. Stepowski**, US Veterans Administration  
(Alternate to VA Rep.)

**Nonvoting**

**R. A. Harris**, Winnipeg, Manitoba, Canada

**PANEL NO. 10—Articles 422, 424, 426**

**Ben Z. Segall**, *Chairman*  
New Orleans, LA

**Alternates**

**Leland Dockery**, Dockery Electrical Co.  
(Rep. Nat'l Electrical Contractors Assn.)

**Charles A. Dubberley**, The Trane Co.  
(Rep. Air-Conditioning & Refrigeration Inst.)

**Edward T. Hoock, Jr.**, Int'l Brotherhood of Electrical Workers, Local 1

**Morris L. Markel**, Thermo-Ray Mfg. Co.  
(Rep. Nat'l Electrical Manufacturers Assn.)  
(Liaison Rep. on ANSI-C101)

**Leo F. Martin**, City of Boston, MA  
(Rep. Int'l Assn. of Electrical Inspectors)

**James W. Reinbold**, General Electric Co.  
(Rep. Assn. of Home Appliance Manufacturers)

**Donald C. Rockholm**, Underwriters Laboratories Inc.

**Leo Stambaugh**, Texas Power & Light Co.  
(Rep. Electric Light & Power Group)

**Robert M. Yurkanin**, Electran Process Int'l Inc.  
(Rep. Inst. of Electrical & Electronics Engineers)

**Joseph Kuntz, Jr.**, National Institute of Health  
(Alternate to L. F. Martin)

**Jerry E. Lawson**, TPI Corp.  
(Alternate to M. L. Markel)

**Alfred B. Marden**, Kidde Systems Inc.  
(Alternate to R. M. Yurkanin)

**Donald Meadows**, Int'l Brotherhood of Electrical Workers, Local 1  
(Alternate to E. T. Hoock, Jr.)

**Herbert C. Skarbek**, Air-Conditioning & Refrigeration Inst.

(Alternate to C. A. Dubberley)

**John T. Weizerick**, Assn. of Home Appliance Manufacturers  
(Alternate to J. W. Reinbold)

**Nonvoting**

**Rick C. Gilmour**, Toronto, Ontario, Canada  
**William H. King, Jr.**, US Consumer Product Safety Commission

**PANEL NO. 11 — Articles 430, 440, 670, Chapter 9 Example No. 8**

**Richard W. Osborn**, *Chairman*  
(Rep. Nat'l Electrical Contractors Assn.)

**Lucas G. Ananian**, General Motors Corp.  
(Rep. Inst. of Electrical & Electronics Engineers)

**Ben L. Auger**, City of Royal Oak, MI  
(Rep. Int'l Assn. of Electrical Inspectors)

**N. Ellis Cannady, Jr.**, M. B. Haynes Electric Co.

**Milton E. Cox**, Underwriters Laboratories Inc.

**Thomas E. Dye**, Olin Corp.  
(Rep. Chemical Manufacturers Assn.)

**William T. Fiske**, ETL Testing Laboratories, Inc.

**Paul P. Gubany**, Bussman Mfg. Div., McGraw-Edison Co.

**T. A. Jacoby**, Tecumseh Products Co.  
(Rep. Air-Conditioning & Refrigeration Inst.)

**Dimitrios M. Karydas**, Factory Mutual Research Corp.

**Miguel G. Lopez**, US Veterans Administration  
**R. C. Mierendorf**, Square D Co.  
(Rep. Nat'l Electrical Manufacturers Assn.)

**David C. Morton**, Bethlehem Steel Corp.  
(Rep. Assn. of Iron & Steel Engineers)

**Joseph A. Schomaker**, The Travelers Insurance Cos.  
(Rep. American Insurance Service Group, Inc.)

**Victor A. Smith**, Virginia Electric & Power Co.  
(Rep. Electric Light & Power Group)

**John E. Taylor**, Int'l Brotherhood of Electrical Workers, Local 103

**A. P. White**, Texas Instruments, Inc.

**Alternates**

**David S. Baker**, Brown & Root USA, Inc.  
(Alternate to L. G. Ananian)

**Charles A. Dubberley**, The Trane Co.  
(Alternate to T. A. Jacoby)

**Francis Finnegan**, Texas Instruments, Inc.  
(Alternate to A. P. White)

**W. E. Greiser**, Bethlehem Steel Corp.  
(Alternate to D. C. Morton)

**Dean H. Klohr**, Bussman Mfg. Div., McGraw-Edison Co.  
(Alternate to P. P. Gubany)

**Walter J. Martiny, Jr.**, General Electric Co.  
(Alternate to R. C. Mierendorf)

**Stanley I. Rzepecki**, Underwriters Laboratories Inc.

(Alternate to M. E. Cox)

**Anthony J. Scalone**, US Veterans Administration  
(Alternate to M. G. Lopez)

**Mark N. Shapiro**, City of Madison Heights, MI  
(Alternate to B. L. Auger)

**Robert H. Stevens**, Florida Power & Light Co.  
(Alternate to V. A. Smith)  
**William M. Swanson, Jr.**, Joint Apprentice &  
Training Comm.  
(Alternate to J. E. Taylor)

**John T. Weizeorick**, Assn. of Home Appliance  
Manufacturers  
(Alternate to Assn. of Home Appliance Manu-  
facturers Rep.)  
**Thomas H. Wood**, Cecil-B. Wood, Inc.  
(Alternate to R. W. Osborn)

**PANEL NO. 12 — Articles 427, 610, 620, 630, 645  
660, 665, 668, 669, 685**

**Bernard W. Whittington**, *Chairman*  
Whittington Engineering, Inc.

**Ralph C. Best**, Niagara Mohawk Power Corp.  
(Rep. Electric Light & Power Group)  
**A. R. Cartal**, Middle Dept. Inspection Agency, Inc.  
(Rep. Int'l Assn. of Electrical Inspectors)  
**Ralph E. Droste**, Otis Elevator Co.  
(Rep. National Elevator Industry, Inc.)  
(Vote limited to Articles 610, 620, 630)  
**C. James Erickson**, E. I. du Pont de Nemours &  
Co.  
(Rep. Chemical Manufacturers Assn.)  
(Vote limited to Articles 427, 610, 645, 660, 665,  
668, 669, 685)  
**Robert G. Harris**, Underwriters Laboratories Inc.  
**B. J. Lowery**, Int'l Brotherhood of Electrical Work-  
ers, Local 175  
**C. L. Pittman**, Maryville, TN  
(Rep. The Aluminum Association)  
(Vote limited to Articles 645, 660, 665, 668, 669,  
685)  
**Robert H. Reuss**, Harnischfeger Corp.  
(Rep. Crane Manufacturers of America Assn.  
& Hoist Manufacturers Institute)  
(Vote limited to Article 610)  
**William C. Rhine**, Cutler-Hammer, Inc.  
(Rep. Nat'l Electrical Manufacturers Assn.)  
**Robert Riley**, IBM Corp.  
(Rep. Computer & Business Equipment Manu-  
facturers  
Assn. & Electronic Industries Assn.)  
(Vote limited to Article 645)

**T. Neil Thoria**, Inland Steel Co.  
(Rep. Assn. of Iron & Steel Engineers)  
(Vote limited to Articles 610, 620, 630)  
**George V. Waters**, Waters Electric, Inc.  
(Rep. Nat'l Electrical Contractors Assn.)

**Alternates**

**John F. Burr**, Consolidation Coal Corp.  
(Alternate to IEEE Rep.)  
**Michael J. DeMartini**, Underwriters Laboratories  
Inc.  
(Alternate to R. G. Harris)  
**Peter J. Dureiko**, Town of Vernon, CT  
(Alternate to A. R. Cartal)  
**James H. Layne**, Reynolds Metals Co.  
(Alternate to C. L. Pittman)  
**Raymond B. Pohlman, Jr.**, Dover Corp.  
(Alternate to R. E. Droste)  
**S. L. Raiston**, PPG Industries, Inc.  
(Alternate to C. J. Erickson)  
**Donald S. Thorburn**, Philips Medical Systems, Inc.  
(Alternate to W. C. Rhine)  
**John N. Wright**, Int'l Brotherhood of Electrical  
Workers, Local 270  
(Alternate to B. J. Lowery)

**PANEL NO. 13 — Articles 450; 460, 470, 710**

**Kernan R. Dennis**, *Chairman*  
Northwest Electric Co.

(Rep. Nat'l Electrical Contractors Assn.)

**W. O. Andersen, Jr.**, Kaiser Aluminum & Chemical  
Corp.  
(Rep. The Aluminum Association)  
**Richard B. Boyd, Jr.**, NC Department of Insurance  
(Rep. Int'l Assn. of Electrical Inspectors)  
**E. E. Carlton**, Menlo Park, CA  
**Mark W. Earley**, Factory Mutual Research Corp.  
**Edwin J. Hansen**, Int'l Brotherhood of Electrical  
Workers, Local 441  
**James J. Jefferson**, Tennessee Eastman Co.  
(Rep. Chemical Manufacturers Assn.)  
**William T. O'Grady**, Underwriters Laboratories  
Inc.  
**John A. O'Neill, Jr.**, US Veterans Administration  
**Milton D. Robinson**, Milt Robinson Engineering  
Co.  
(Rep. Inst. of Electrical & Electronics  
Engineers)  
**W. E. Thomas**, Westinghouse Electric Corp.  
(Rep. Nat'l Electrical Manufacturers Assn.)  
**John W. Troglia**, Wisconsin Electric Power Co.  
(Rep. Electric Light & Power Group)

**Robert I. Tudor**, Electro Test Inc.  
(Rep. Nat'l Electrical Testing Assn.)

**Alternates**

**Bruce A. Baxter**, Int'l Brotherhood of Electrical  
Workers, Local 332  
(Alternate to E. J. Hansen)  
**Harry A. Burr**, US Veterans Administration  
(Alternate to J. A. O'Neill, Jr.)  
**Richard P. Fogarty**, Consolidated Edison of New  
York  
(Alternate to J. W. Troglia)  
**Robert G. Hames**, Underwriters Laboratories Inc.  
(Alternate to W. T. O'Grady)  
**Joseph W. Hupp**, Acme Transformer  
(Alternate to W. E. Thomas)  
**Walter Kroboth**, Exxon Chemical Co.  
(Alternate to J. J. Jefferson)  
**Charles S. Rennells**, Empire Electric Co.  
(Alternate to K. R. Dennis)  
**Robert L. Simpson**, Monsanto Enviro-Chem Sys-  
tems, Inc.  
(Alternate to M. D. Robinson)  
**A. R. Thompson**, City of Durham, NC  
(Alternate to R. B. Boyd, Jr.)

**PANEL NO. 14 — Articles 500, 501, 502, 503, 510, 511,  
513, 514, 515, 516**

**Leland J. Hall, Chairman**  
Carson City, NV

**F. D. Alroth**, Underwriters Laboratories Inc.  
**Richard J. Buschart**, Monsanto Co.  
(Rep. Chemical Manufacturers Assn.)  
**C. W. Conaway**, Industrial Risk Insurers  
**Mark W. Earley**, Factory Mutual Research Corp.  
**Clarence B. Joriman**, City of New Brighton, MN  
(Rep. Int'l Assn. of Electrical Inspectors)  
**Gerald W. Lemberg**, Lemberg Electric Co., Inc.  
(Rep. Nat'l Electrical Contractors Assn.)  
**Ernest C. Magison**, Honeywell  
(Rep. Scientific Apparatus Makers Assn.)  
**Donald T. Murphy**, Ralston Purina Co.  
(Rep. American Feed Manufacturers Assn., Inc.)  
(Vote limited to Articles 500, 502)  
**Walter A. Short**, Crouse-Hinds Co.  
(Rep. Nat'l Electrical Manufacturers Assn.)  
**Harold B. Smith**, Cargill, Inc.  
(Rep. Grain Elevator & Processing Society)  
**Lawrence C. Strachota**, Iowa Power & Light Co.  
(Rep. Electric Light & Power Group)  
**William T. Trinker**, The Mill Mutuals  
**James A. Weldon**, Int'l Brotherhood of Electrical Workers, Local 728

**Alternates**

**Albert A. Bartkus**, Underwriters Laboratories Inc.  
(Alternate to F. D. Alroth)  
**Dan C. Bowers**, Int'l Brotherhood of Electrical Workers, Local 413  
(Alternate to J. A. Weldon)  
**Marion A. Cabler**, Phillips Petroleum Co.  
(Alternate to R. J. Buschart)  
**Robert D. Epstein**, Detroit Edison Co.  
(Alternate to L. C. Strachota)  
**Joseph H. Kuczka**, Killark Electric Mfg. Co.  
(Alternate to W. A. Short)  
**Francis J. McGowan**, The Foxboro Co.  
(Alternate to E. C. Magison)  
**David F. Moorhead**, H. K. Webster Co., Inc.  
(Alternate to D. T. Murphy)  
**W. L. Raines**, St. Louis County Dept. of Public Works, MO.  
(Alternate to C. B. Joriman)  
**Warren Stancl**, The Mill Mutuals  
(Alternate to W. T. Trinker)

**Nonvoting**

**John A. Bossert**, Energy Mines & Resources,  
Ottawa, Ontario, Canada

**PANEL NO. 15 — Articles 445, 480, 518, 520, 530,  
540, 700, 701, 702, 705**

**James G. Stallcup, Chairman**  
City of Ft. Worth, TX  
(Rep. Int'l Assn. of Electrical Inspectors)

**George W. Flach**, Flach Consultants  
**V. C. Holloway**, Interstate Electric Co.  
(Rep. Nat'l Electrical Contractors Assn.)  
**George T. Howard**, George T. Howard Associates  
(Vote limited to Articles 518, 520, 530, 540)  
**John A. Hunter**, Int'l Brotherhood of Electrical Workers, Local 302  
**LaVell J. Jensen**, Utah Power & Light Co.  
(Rep. Electric Light & Power Group)  
**Jack W. Kalbfeld**, Kalico Technology, Inc.  
(Vote limited to Articles 518, 520, 530, 540)  
**R. W. Kenny**, AT&T Bell Labs  
(Vote limited to Articles 445, 480, 700, 701, 702, 705)  
**J. J. Kubisz**, Underwriters Laboratories Inc.  
**Michael A. Lanni**, Universal City Studios  
(Rep. Motion Picture Assn. of America, Inc.)  
(Vote limited to Articles 518, 520, 530, 540)  
**Frank J. Mapp**, Bell Communications Research, Inc.  
(Rep. Exchange Carriers Standards Assn.)  
(Vote limited to Articles 445, 480, 700, 701, 702, 705)  
**W. M. Riches**, Nat'l Accelerator Laboratories  
(Vote limited to Articles 518, 520, 530, 540)  
**Anthony J. Scalone**, US Veterans Administration  
(Vote limited to Articles 445, 480, 700, 701, 702)  
**Jay A. Stewart**, FMC Corp.  
(Rep. Chemical Manufacturers Assn.)  
**David G. Strasser**, Marathon Electric Mfg. Co.  
(Rep. Nat'l Electrical Manufacturers Assn.)

**Georg Stromme**, Roseville, MN  
(Rep. Electrical Generating Systems Marketing Assn.)

**Alternates**

**James W. Carpenter**, NC Department of Insurance  
(Alternate to J. G. Stallcup)  
**Charles Crawford**, Int'l Brotherhood of Electrical Workers, Local 163  
(Alternate to J. A. Hunter)  
**Gordon S. Johnson**, Kohler Co.  
(Alternate to G. Stromme)  
**Miguel G. Lopez**, US Veterans Administration  
(Alternate to A. J. Scalone)  
**Ron H. Minter**, Chloride Systems  
(Alternate to D. G. Strasser)  
**S. G. Roll**, Underwriters Laboratories Inc.  
(Alternate to J. J. Kubisz)  
**Paul D. Speranza**, Bell Communications Research, Inc.  
(Alternate to F. J. Mapp)  
**John A. Taylor**, Alabama Power Co.  
(Alternate to L. J. Jensen)  
**David Young**, Allied Chemical Corp.  
(Alternate to J. A. Stewart)  
**Donald W. Zipse**, FMC Corp.  
(Alternate to Inst. of Electrical & Electronics Engineers Rep.)

**Nonvoting**

**J. C. Stevens**, Office of the Fire Marshal  
Toronto, Ontario, Canada



PANEL NO. 16 — Articles 640, 650, 720, 725,  
760, 770, 800, 810, 820

**D. Harold Ware**, *Chairman*  
Libra Electric Co.

(Rep. Nat'l Electrical Contractors Assn.)

**Edward J. Cohen**, US Department of Agriculture,  
Rural Electrification Administration

**Charles D. Hansell**, Charles D. Hansell Consult-  
ants, Inc.

(Rep. Inst. of Electrical & Electronics  
Engineers)

**William R. Hitchens**, Myrtle Beach, SC  
(Rep. Chemical Manufacturers Assn.)

**Michael A. Lanni**, Universal City Studios  
(Rep. Motion Picture Assn. of America, Inc.)  
(Vote limited to Articles 640, 720, 725, 760, 810,  
820)

**Raymond I. Lease, Jr.**, Middle Dept. Insp. Agency  
(Rep. Int'l Assn. of Electrical Inspectors)

**Irving Mande**, Edwards Co., Inc.  
(Rep. Nat'l Electrical Manufacturers Assn.)  
(Liaison to NFPA Signaling Systems Commit-  
tee)

**H. Marvin McNeil**, Siecior Corp.  
(Rep. Insulated Cable Engineers Assn., Inc.)

**Paul F. Ryder**, Northeast Utilities  
(Rep. Electric Light & Power Group)

**William Schallhammer**, Underwriters Laboratories  
Inc.

**Len H. Sessler**, Bell Communications Research  
(Rep. Exchange Carriers Standards Assn.)

**Johnny D. Southwell**, Int'l Brotherhood of Electri-  
cal Workers, Local 1141

**Alternates**

**S. E. Edgesdal**, Honeywell, Inc.  
(Alternate to I. Mande)

**John Mangan**, Medford City Hall, MA  
(Alternate to R. I. Lease, Jr.)

**Keneth L. Miller**, Int'l Brotherhood of Electrical  
Workers, Local 661

(Alternate to J. D. Southwell)  
**David Wechsler**, Union Carbide Corp.  
(Alternate to W. R. Hitchens)

**Nonvoting**

**A. T. Care**, Manitoba Telephone System,  
Winnipeg, Manitoba, Canada

PANEL NO. 17 — Article 517

**George Schuck, Jr.**, *Chairman*

Int'l Brotherhood of Electrical Workers, Local 3

**Kenneth J. Dragmen**, Picker Corp.  
(Rep. Nat'l Electrical Manufacturers Assn.)

**William R. Drake**, Daniel Woodhead Co.  
(Rep. National Safety Council)

**Alvin R. Friendlich**, MET Electrical Testing Co.,  
Inc.  
(Rep. Nat'l Electrical Testing Assn., Inc.)

**Jerald M. Gerber**, Cleveland Electric Ill. Co.  
(Rep. Electric Light & Power Group)

**Allen E. Hubble**, Dept. of Labor & Industrial Serv-  
ices

(Rep. Int'l Assn. of Electrical Inspectors)

**Stanley D. Kahn**, Eastern States-Kahn Electric,  
Inc.

(Rep. Nat'l Electrical Contractors Assn.)

**Glenn T. Keates**, Catherine McAuley Health Cen-  
ter

(Rep. Inst. of Electrical & Electronics  
Engineers)

**Ode Richard Keil**, Joint Commission of Accredita-  
tion of  
Hospitals

**Ralph Loeb**, Sherlock, Smith & Adams, Inc.  
(Rep. Health Care Facilities Correlating Com-  
mittee)

**Michael T. Merrigan**, Underwriters Laboratories  
Inc.

**James A. Meyer**, Pettis Memorial VA Hospital.  
(Rep. American Society of Anesthesiologists)

**Hugh O. Nash, Jr.**, Smith, Seckman, Reid, Inc.

**Gary D. Slack**, Medical Instrumentation Systems,  
Inc.

(Rep. American Hospital Association)

**Howard C. Stauffer**, Hospital Corp. of America  
(Rep. NFPA Health Care Section)

**Jeffrey L. Steplowski**, US Veterans Administration

**Alternates**

**Edwin H. Hoeltke**, The Christ Hosp.

(Alternate to G. Schuck, Jr.)

**Gerald L. Kavanaugh**, Int'l Brotherhood of Electri-  
cal

Workers, Local 145

(Alternate to G. Schuck, Jr.)

**Mary Ann Kelly**, American Hospital Assn.

(Alternate to G. D. Slack)

**Cecil Kight**, US Dept. of Labor & Ind. Services

(Alternate to A. E. Hubble)

**Richard W. Nalbert**, Square D Co.

(Alternate to K. J. Dragmen)

**Ray O'Leary**, O'Leary Electric Co.

(Alternate to S. D. Kahn)

**Bryan Parker**, Montefiore Hospital & Medical Ctr.  
(Alternate to Assn. for Advancement of Medical  
Instrumentation Rep.)

**George N. Webb**, Baltimore, MD

(Alternate to G. T. Keates)

**Nonvoting**

**Chris McGregor**, Vancouver, BC, Canada

## PANEL NO. 18 — Articles 410, 600, 605

A. F. KnickKrehm, *Chairman*

The KnickKrehm Co.

(Rep. Nat'l Electrical Contractors Assn.)

Russel J. Helmick, Jr., City of Irvine, CA

(Rep. Int'l Assn. of Electrical Inspectors)

Robert J. Illig, Int'l Brotherhood of Electrical Workers, Local 7

Mark Johnson, Heath &amp; Co.

(Rep. Nat'l Electric Sign Assn.)

(Vote limited to Article 600)

Kenneth F. Kempel, Underwriters Laboratories Inc.

E. G. Kiener, Solar Turbine, Inc.

(Rep. Inst. of Electrical &amp; Electronics Engineers)

Bernard J. Mezger, Bostrom Management

(Rep. American Home Lighting Institute)

(Vote limited to Article 410)

Walter A. Short, Crouse-Hinds Co.

(Rep. Nat'l Electrical Manufacturers Assn.)

James P. Suttle, Ohio Edison Co.

(Rep. Electric Light &amp; Power Group)

Jack Wells, Pass &amp; Seymour, Inc.

## Alternates

Richard K. Bertoch, Wasatch Electric Co.

(Alternate to A. F. KnickKrehm)

James T. Duffy, Underwriters Laboratories Inc.

(Alternate to K. F. Kempel)

Kenneth B. Leech, Int'l Brotherhood of Electrical Workers, Local 35

(Alternate to R. J. Illig)

Saul Rosenbaum, Leviton Manufacturing Co., Inc.

(Alternate to W. A. Short)

Thomas E. Trainor, City of San Diego, CA

(Alternate to R. J. Helmick, Jr.)

Sidney Wolkin, Lightolier, Inc.

(Alternate to B. J. Mezger)

## Nonvoting

B. H. Chick, Public Works, Canada

## PANEL NO. 19 — Articles 545, 547, 550, 551, 604, 675

J. Philip Simmons, *Chairman*

State of Washington

(Rep. Int'l Assn. of Electrical Inspectors)

Russ Bahr, RADCO

(Vote limited to Articles 550, 551)

Barry Bauman, Wisconsin Power &amp; Light Co.

(Rep. American Society of Agricultural Engineers)

(Vote limited to Articles 545, 547, 604, 675)

Douglas R. Betts, Fleetwood Enterprises, Inc.

(Rep. Western Manufactured Housing Institute)

(Vote limited to Articles 550, 551)

A. L. Buxton, Burndy Corp.

(Rep. Nat'l Electrical Manufacturers Assn.)

Paul Duks, Underwriters Laboratories Inc.

Randol O. Farlow, Georgia Power Co.

(Rep. Electric Light &amp; Power Group)

James W. Finch, Kampgrounds of America, Inc.

(Vote limited to Articles 550, 551)

Bruce A. Hopkins, Recreation Vehicle Industry Assn.

(Vote limited to Articles 550, 551)

Melvin Kallenbach, Mel-Kay Electric Co., Inc.

(Rep. Nat'l Electrical Contractors Assn.)

Marvin Nabben, Nat'l Assn. of Mutual Insurance Cos.

(Rep. Reinsurance Assn. of Minnesota)

(Vote limited to Articles 545, 547, 604, 675)

Glenn C. Safford, Kirby Risk Supply Co., Inc.

(Rep. Nat'l Assn. of Electrical Distributors)

(Vote limited to Articles 545, 547, 604, 675)

Owen Schleisman, Int'l Brotherhood of Electrical Workers, Local 292

Irving Schwartz, Irving Schwartz Associates

(Vote limited to Articles 545, 547, 604, 675)

Warren Stancel, The Mill Mutuals

(Vote limited to Article 547)

Ed Starostovic, PFS Corp.

(Rep. Nat'l Assn. of Home Manufacturers)

(Vote limited to Articles 545, 547, 604, 675)

Kent P. Stiner, Traverse City, MI

## Alternates

Richard J. Carnaroli, Northeast Utilities Service Co.

(Alternate to R. O. Farlow)

Bob E. Fesmire, Int'l Brotherhood of Electrical Workers, Local 835

(Alternate to O. Schleisman)

Richard McEnroe, The Mill Mutuals

(Alternate to W. Stancel)

Henry Omson, RADCO

(Alternate to R. Bahr)

James N. Pearce, Leviton Manufacturing Co.

(Alternate to A. L. Buxton)

Howard Stemmer, Washington State

(Alternate to J. P. Simmons)

Truman C. Surbrook, Michigan State University

(Alternate to B. Bauman)

## PANEL NO. 20 — Articles 553, 555, 680

Charles R. Pierce, *Chairman*

Fresno, CA

(Rep. Int'l Assn. of Electrical Inspectors)

Vincent L. Carissimi, Harvey Hubbell, Inc.

(Rep. Nat'l Electrical Manufacturers Assn.)

Donald E. Fritz, PA Power &amp; Light

(Rep. Electric Light &amp; Power Group)

Herbert H. Howard, American Products

(Rep. Nat'l Spa &amp; Pool Inst.)

(Vote limited to Article 680)

Warren E. Jackson, The Travelers Insurance Co.

(Rep. American Insurance Services Group Inc.)

Wayne Menuz, Underwriters Laboratories Inc.

**D. Nestor**, Nestor Engineering Co.  
(Rep. National Safety Council)

**Philip Sperber**, KDI Paragon, Inc.  
(Vote limited to Article 680)

**Thomas J. Sweeney**, Int'l Brotherhood of Electrical  
Workers, Local 595

**Seldon E. Tucker**, Allied Electrical Construction  
Co., Inc.

(Rep. Nat'l Electrical Contractors Assn.)

**Charles E. Wade**, Wade Design, Inc.  
(Vote limited to Article 680)

#### Alternates

**Albert J. Bernardi**, Underwriters Laboratories Inc.  
(Alternate to W. Menuz)

**Charles W. Draper**, Square D Co.  
(Alternate to V. L. Carissimi)

**C. Levoir**, County of Orange, CA  
(Alternate to C. R. Pierce)

**James R. McNicol**, Brett Aqualine  
(Alternate to H. H. Howard)

**William D. Swearingen**, Fireman's Fund Insurance  
Cos.

(Alternate to W. E. Jackson)

**Wayne Thomas**, Int'l Brotherhood of Electrical  
Workers, Local 617

(Alternate to T. J. Sweeney)

**Kyle E. Todd**, Gulf States Utilities Co.  
(Alternate to D. E. Fritz)

#### Nonvoting

**G. W. Lawrence**, Canadian Standards Assn.

*This list represents the membership at the time the Committee was balloted on the text of this edition. Since that time, changes in the membership may have occurred.*

NOTE: Membership on a Committee shall not in and of itself constitute an endorsement of the Association or any document developed by the Committee on which the member serves.

# National Electrical Code

## NFPA 70

### ARTICLE 90 — INTRODUCTION

#### 90-1. Purpose.

(a) **Practical Safeguarding.** The purpose of this Code is the practical safeguarding of persons and property from hazards arising from the use of electricity.

(b) **Adequacy.** This Code contains provisions considered necessary for safety. Compliance therewith and proper maintenance will result in an installation essentially free from hazard, but not necessarily efficient, convenient, or adequate for good service or future expansion of electrical use.

(FPN): Hazards often occur because of overloading of wiring systems by methods or usage not in conformity with this Code. This occurs because initial wiring did not provide for increases in the use of electricity. An initial adequate installation and reasonable provisions for system changes will provide for future increases in the use of electricity.

(c) **Intention.** This Code is not intended as a design specification nor an instruction manual for untrained persons.

#### 90-2. Scope.

(a) **Covered.** This Code covers:

(1) Installations of electric conductors and equipment within or on public and private buildings or other structures, including mobile homes, recreational vehicles, and floating buildings; and other premises such as yards, carnival, parking and other lots, and industrial substations.

(FPN): For additional information concerning such installations in an industrial or multibuilding complex, see the National Electrical Safety Code, ANSI C2-1984.

(2) Installations of conductors that connect to the supply of electricity.

(3) Installations of other outside conductors on the premises.

(4) Installations of optical fiber cable.

(b) **Not Covered.** This Code does not cover:

(1) Installations in ships, watercraft other than floating buildings, railway rolling stock, aircraft, or automotive vehicles other than mobile homes and recreational vehicles.

(2) Installations underground in mines.

(3) Installations of railways for generation, transformation, transmission, or distribution of power used exclusively for operation of rolling stock or installations used exclusively for signaling and communication purposes.

(4) Installations of communication equipment under the exclusive control of communication utilities, located outdoors or in building spaces used exclusively for such installations.

(5) Installations under the exclusive control of electric utilities for the purpose of communication, or metering; or for the generation, control, transformation, transmission, and distribution of electric energy located in buildings used exclusively by utilities for such purposes or located outdoors on property owned or leased by the utility or on public highways, streets, roads, etc., or outdoors by established rights on private property.

(FPN): It is the intent of this section that this Code covers all premises' wiring or wiring other than utility owned metering equipment, on the load side of the service point of buildings, structures, or any other premises not owned or leased by the utility. Also, it is the intent that this Code cover installations in buildings used by the utility for purposes other than listed in (b)(5) above, such as office buildings, warehouses, garages, machine shops, and recreational buildings which are not an integral part of a generating plant, substation, or control center.

(c) **Special Permission.** The authority having jurisdiction for enforcing this Code may grant exception for the installation of conductors and equipment, not under the exclusive control of the electric utilities and used to connect the electric utility supply system to the service-entrance conductors of the premises served, provided such installations are outside a building or terminate immediately inside a building wall.

**90-3. Code Arrangement.** This Code is divided into the Introduction and nine chapters. Chapters 1, 2, 3, and 4 apply generally; Chapters 5, 6, and 7 apply to special occupancies, special equipment, or other special conditions. These latter chapters supplement or modify the general rules. Chapters 1 through 4 apply except as amended by Chapters 5, 6, and 7 for the particular conditions.

Chapter 8 covers communications systems and is independent of the other chapters except where they are specifically referenced therein.

Chapter 9 consists of tables and examples.

Material identified by the superscript letter "x" includes text extracted from other NFPA documents as identified in Appendix A.

**90-4. Enforcement.** This Code is intended to be suitable for mandatory application by governmental bodies exercising legal jurisdiction over electrical installations and for use by insurance inspectors. The authority having jurisdiction of enforcement of the Code will have the responsibility for making interpretations of the rules, for deciding upon the approval of equipment and materials, and for granting the special permission contemplated in a number of the rules.

The authority having jurisdiction may waive specific requirements in this Code or permit alternate methods, where it is assured that equivalent objectives can be achieved by establishing and maintaining effective safety.

This Code may require new products, constructions, or materials which may not yet be available at the time the Code is adopted. In such event, the authority having jurisdiction may permit the use of the products, constructions, or materials which comply with the most recent previous edition of this Code adopted by the jurisdiction.

**90-5. Formal Interpretations.** To promote uniformity of interpretation and application of the provisions of this Code, Formal Interpretation procedures have been established.

(FPN): These procedures may be found in the "NFPA Regulations Governing Committee Projects."

**90-6. Examination of Equipment for Safety.** For specific items of equipment and materials referred to in this Code, examinations for safety made under standard conditions will provide a basis for approval where the record is made generally available through promulgation by organizations properly equipped and qualified for experimental testing, inspections of the run of goods at factories, and service-value determination through field inspections. This avoids the necessity for repetition of examinations by different examiners, frequently with inadequate facilities for such work, and the confusion that would result from conflicting reports as to the suitability of devices and materials examined for a given purpose.

It is the intent of this Code that factory-installed internal wiring or the construction of equipment need not be inspected at the time of installation of the equipment, except to detect alterations or damage, if the equipment has been listed by a qualified electrical testing laboratory which is recognized as having the facilities described above and which requires suitability for installation in accordance with this Code.

(FPN): See Examination of Equipment, Section 110-3.

(FPN): See definition of "Listed," Article 100.

**90-7. Wiring Planning.**

(a) **Future Expansion and Convenience.** Plans and specifications that provide ample space in raceways, spare raceways, and additional spaces will allow for future increases in the use of electricity. Distribution centers located in readily accessible locations will provide convenience and safety of operation. See Sections 110-16 and 240-24 for clearances and accessibility.

(b) **Number of Circuits in Enclosures.** It is elsewhere provided in this Code that the number of wires and circuits confined in a single enclosure be varyingly restricted. Limiting the number of circuits in a single enclosure will minimize the effects from a short-circuit or ground fault in one circuit.

**90-8. Metric Units of Measurement.** For the purpose of this Code metric units of measurement are in accordance with the modernized metric system known as the International System of Units (SI).

Values of measurement in the Code text will be followed by an approximate equivalent value in SI units. Tables will have a footnote for SI conversion units used in the table.

Conduit size, wire size, horsepower designation for motors, and trade sizes that do not reflect actual measurements, e.g., box sizes, will not be assigned dual designation SI units.

(FPN): For metric conversion practices, see ANSI/ASTM E380-1984, Standard for Metric Practice.



## Chapter 1. General

### ARTICLE 100 — DEFINITIONS

**Scope.** This article contains only those definitions essential to the proper application of this Code. It is not intended to include commonly defined general terms nor commonly defined technical terms from related codes and standards. In general, only those terms used in two or more articles are defined in Article 100. Other definitions are included in the article in which they are used but may be referenced in Article 100.

Part A of this article contains definitions intended to apply wherever the terms are used throughout this Code. Part B contains definitions applicable only to the parts of articles covering specifically installations and equipment operating at over 600 volts, nominal.

#### A. General

**AC General-Use Snap Switch:** See under "Switches."

**AC-DC General-Use Snap Switch:** See under "Switches."

**Accessible:** (As applied to wiring methods.) Capable of being removed or exposed without damaging the building structure or finish, or not permanently closed in by the structure or finish of the building. (See "Concealed" and "Exposed.")

**Accessible:** (As applied to Equipment.) Admitting close approach: not guarded by locked doors, elevation, or other effective means. (See "Accessible, Readily.")

**Accessible, Readily:** (Readily Accessible.) Capable of being reached quickly for operation, renewal, or inspections, without requiring those to whom ready access is requisite to climb over or remove obstacles or to resort to portable ladders, chairs, etc. (See "Accessible.")

**Ampacity:** The current in amperes a conductor can carry continuously under the conditions of use without exceeding its temperature rating.

**Anesthetizing Location:** See Section 517-2.

**Appliance:** Utilization equipment, generally other than industrial, normally built in standardized sizes or types, which is installed or connected as a unit to perform one or more functions such as clothes washing, air conditioning, food mixing, deep-frying, etc.

**Appliance Branch Circuit:** See "Branch Circuit, Appliance."

**Approved:** Acceptable to the authority having jurisdiction.

**Askarel:** A generic term for a group of nonflammable synthetic chlorinated hydrocarbons used as electrical insulating media. Askarels of various compositional types are used. Under arcing conditions the gases produced, while consisting predominantly of noncombustible hydrogen chloride, can include varying amounts of combustible gases depending upon the askarel type.



**Attachment Plug (Plug Cap) (Cap):** A device which, by insertion in a receptacle, establishes connection between the conductors of the attached flexible cord and the conductors connected permanently to the receptacle.

**Automatic:** Self-acting, operating by its own mechanism when actuated by some impersonal influence, as for example, a change in current strength, pressure, temperature, or mechanical configuration. (See "Nonautomatic.")

**Bare Conductor:** See under "Conductor."

**Block (City, Town, or Village):** See Section 800-2.

**Bonding:** The permanent joining of metallic parts to form an electrically conductive path which will assure electrical continuity and the capacity to conduct safely any current likely to be imposed.

**Bonding Jumper:** A reliable conductor to assure the required electrical conductivity between metal parts required to be electrically connected.

**Bonding Jumper, Circuit:** The connection between portions of a conductor in a circuit to maintain required ampacity of the circuit.

**Bonding Jumper, Equipment:** The connection between two or more portions of the equipment grounding conductor.

**Bonding Jumper, Main:** The connection between the grounded circuit conductor and the equipment grounding conductor at the service.

**Branch Circuit:** The circuit conductors between the final overcurrent device protecting the circuit and the outlet(s).

(FPN): See Section 240-9 and Section 240-10 for thermal cutouts, thermal relays, supplementary overcurrent protection, and other devices.

**Branch Circuit, Appliance:** A branch circuit supplying energy to one or more outlets to which appliances are to be connected; such circuits to have no permanently connected lighting fixtures not a part of an appliance.

**Branch Circuit, General Purpose:** A branch circuit that supplies a number of outlets for lighting and appliances.

**Branch Circuit, Individual:** A branch circuit that supplies only one utilization equipment.

**Branch Circuit, Multiwire:** A branch circuit consisting of two or more ungrounded conductors having a potential difference between them, and a grounded conductor having equal potential difference between it and each ungrounded conductor of the circuit and which is connected to the neutral conductor of the system.

**Branch-Circuit Selection Current:** See Section 440-4(c), Definition.

**Building:** A structure which stands alone or which is cut off from adjoining structures by fire walls with all openings therein protected by approved fire doors.

**Cabinet:** An enclosure designed either for surface or flush mounting and provided with a frame, mat, or trim in which a swinging door or doors are or may be hung.

**Cell (As applied to Raceways):** See Sections 356-1 and 358-2.

**Circuit Breaker:** A device designed to open and close a circuit by nonautomatic means and to open the circuit automatically on a predetermined overcurrent without injury to itself when properly applied within its rating.

(FPN): The automatic opening means can be integral, direct acting with the circuit breaker or remote from the circuit breaker. See definition of "Switching Devices" in Part B of this article for definition applying to circuits and equipment over 600 volts, nominal.

**Adjustable:** (As applied to Circuit Breakers.) A qualifying term indicating that the circuit breaker can be set to trip at various values of current and/or time within a predetermined range.

**Instantaneous Trip:** (As applied to Circuit Breakers.) A qualifying term indicating that no delay is purposely introduced in the tripping action of the circuit breaker.

**Inverse Time:** (As applied to Circuit Breakers.) A qualifying term indicating there is purposely introduced a delay in the tripping action of the circuit breaker, which delay decreases as the magnitude of the current increases.

**Nonadjustable:** (As applied to Circuit Breakers.) A qualifying term indicating that the circuit breaker does not have any adjustment to alter the value of current at which it will trip or the time required for its operation.

**Setting:** (of Circuit Breaker.) The value of current and/or time at which an adjustable circuit breaker is set to trip.

**Concealed:** Rendered inaccessible by the structure or finish of the building. Wires in concealed raceways are considered concealed, even though they may become accessible by withdrawing them. [See "Accessible — (As applied to wiring methods)."]

**Conductor:**

**Bare:** A conductor having no covering or electrical insulation whatsoever. (See "Conductor, Covered.")

**Covered:** A conductor encased within material of composition or thickness that is not recognized by this Code as electrical insulation. (See "Conductor, Bare.")

**Insulated:** A conductor encased within material of composition and thickness that is recognized by this Code as electrical insulation.

**Conduit Body:** A separate portion of a conduit or tubing system that provides access through a removable cover(s) to the interior of the system at a junction of two or more sections of the system or at a terminal point of the system.

Boxes such as FS and FD or larger cast or sheet metal boxes are not classified as conduit bodies. See Table 370-6(a).

**Connector, Pressure (Solderless):** A device that establishes a connection between two or more conductors or between one or more conductors and a terminal by means of mechanical pressure and without the use of solder.

**Continuous Duty:** See under "Duty."

**Continuous Load:** A load where the maximum current is expected to continue for three hours or more.

**Control Circuit:** See Section 430-71.

**Controller:** A device or group of devices that serves to govern, in some predetermined manner, the electric power delivered to the apparatus to which it is connected. See also Section 430-81(a).

**Cooking Unit, Counter-Mounted:** A cooking appliance designed for mounting in or on a counter and consisting of one or more heating elements,

internal wiring, and built-in or separately mountable controls. (See "Oven, Wall-Mounted.")

**Copper-Clad Aluminum Conductors:** Conductors drawn from a copper-clad aluminum rod with the copper metallurgically bonded to an aluminum core. The copper forms a minimum of 10 percent of the cross-sectional area of a solid conductor or each strand of a stranded conductor.

**Covered Conductor:** See under "Conductor."

**Current-Limiting Overcurrent Protective Device:** See Section 240-11.

**Cutout Box:** An enclosure designed for surface mounting and having swinging doors or covers secured directly to and telescoping with the walls of the box proper. (See "Cabinet.")

**Damp Location:** See under "Location."

**Dead Front:** Without live parts exposed to a person on the operating side of the equipment.

**Demand Factor:** The ratio of the maximum demand of a system, or part of a system, to the total connected load of a system or the part of the system under consideration.

**Device:** A unit of an electrical system which is intended to carry but not utilize electric energy.

**Disconnecting Means:** A device, or group of devices, or other means by which the conductors of a circuit can be disconnected from their source of supply.

(FPN): See definition in Part B of this article for definition applying to circuits and equipment over 600 volts, nominal.

**Dry Location:** See under "Location."

**Dust-Ignitionproof:** See Section 502-1.

**Dustproof:** So constructed or protected that dust will not interfere with its successful operation.

**Dusttight:** So constructed that dust will not enter the enclosing case under specified test conditions.

(FPN): For test conditions other than for rotating equipment, see ANSI/NEMA 250-1979, Enclosures for Electrical Equipment, Paragraph 250.5.05.

#### **Duty:**

**Continuous Duty:** Operation at a substantially constant load for an indefinitely long time.

**Intermittent Duty:** Operation for alternate intervals of (1) load and no load; or (2) load and rest; or (3) load, no load, and rest.

**Periodic Duty:** Intermittent operation in which the load conditions are regularly recurrent.

**Short-Time Duty:** Operation at a substantially constant load for a short and definitely specified time.

**Varying Duty:** Operation at loads, and for intervals of time, both of which may be subject to wide variation.

(FPN): See Table 430-22(a), Exception for illustration of various types of duty.

**Duty Cycle (Welding):** See Section 630-31(b), Fine Print Note.

**Dwelling:**

**Dwelling Unit:** One or more rooms for the use of one or more persons as a housekeeping unit with space for eating, living, and sleeping, and permanent provisions for cooking and sanitation.

**Multifamily Dwelling:** A building containing three or more dwelling units.

**One-Family Dwelling:** A building consisting solely of one dwelling unit.

**Two-Family Dwelling:** A building consisting solely of two dwelling units.

**Electric Sign:** A fixed, stationary, or portable self-contained, electrically illuminated utilization equipment with words or symbols designed to convey information or attract attention.

**Enclosed:** Surrounded by a case, housing, fence, or walls which will prevent persons from accidentally contacting energized parts.

**Enclosure:** The case or housing of apparatus, or the fence or walls surrounding an installation to prevent personnel from accidentally contacting energized parts, or to protect the equipment from physical damage.

(FPN): For enclosure types, see ANSI/NEMA 250-1979, Enclosures for Electrical Equipment (1000 Volts Maximum).

**Equipment:** A general term including material, fittings, devices, appliances, fixtures, apparatus, and the like used as a part of, or in connection with, an electrical installation.

**Equipment Grounding Conductor:** See "Grounding Conductor, Equipment."

**Explosionproof Apparatus:** Apparatus enclosed in a case that is capable of withstanding an explosion of a specified gas or vapor which may occur within it and of preventing the ignition of a specified gas or vapor surrounding the enclosure by sparks, flashes, or explosion of the gas or vapor within, and which operates at such an external temperature that a surrounding flammable atmosphere will not be ignited thereby.

**Exposed:** (As applied to live parts.) Capable of being inadvertently touched or approached nearer than a safe distance by a person. It is applied to parts not suitably guarded, isolated, or insulated. (See "Accessible" and "Concealed.")

**Exposed:** (As applied to wiring methods.) On or attached to the surface or behind panels designed to allow access. [See "Accessible — (As applied to wiring methods)."]

**Externally Operable:** Capable of being operated without exposing the operator to contact with live parts.

**Feeder:** All circuit conductors between the service equipment or the source of a separately derived system and the final branch-circuit overcurrent device.

**Festoon Lighting:** See Section 225-6(b).

**Fitting:** An accessory such as a locknut, bushing, or other part of a wiring system that is intended primarily to perform a mechanical rather than an electrical function.

**Garage:** A building or portion of a building in which one or more self-propelled vehicles carrying volatile flammable liquid for fuel or power are kept for use, sale, storage, rental, repair, exhibition, or demonstrating purposes, and all that portion of a building which is on or below the floor or floors in which such vehicles are kept and which is not separated therefrom by suitable cutoffs.

(FPN): See Section 511-1.

**General-Purpose Branch Circuit:** See "Branch Circuit, General Purpose."

**General-Use Snap Switch:** See under "Switches."

**General-Use Switch:** See under "Switches."

**Ground:** A conducting connection, whether intentional or accidental, between an electrical circuit or equipment and the earth, or to some conducting body that serves in place of the earth.

**Grounded:** Connected to earth or to some conducting body that serves in place of the earth.

**Grounded (Effectively Grounded Communication System):** See Section 800-2(c)(1).

**Grounded Conductor:** A system or circuit conductor that is intentionally grounded.

**Grounding Conductor:** A conductor used to connect equipment or the grounded circuit of a wiring system to a grounding electrode or electrodes.

**Grounding Conductor, Equipment:** The conductor used to connect the noncurrent-carrying metal parts of equipment, raceways, and other enclosures to the system grounded conductor and/or the grounding electrode conductor at the service equipment or at the source of a separately derived system.

**Grounding Electrode Conductor:** The conductor used to connect the grounding electrode to the equipment grounding conductor and/or to the grounded conductor of the circuit at the service equipment or at the source of a separately derived system.

**Ground-Fault Circuit-Interrupter:** A device intended for the protection of personnel that functions to de-energize a circuit or portion thereof within an established period of time when a current to ground exceeds some predetermined value that is less than that required to operate the overcurrent protective device of the supply circuit.

**Ground-Fault Protection of Equipment:** A system intended to provide protection of equipment from damaging line-to-ground fault currents by operating to cause a disconnecting means to open all ungrounded conductors of the faulted circuit. This protection is provided at current levels less than those required to protect conductors from damage through the operation of a supply circuit overcurrent device.

**Guarded:** Covered, shielded, fenced, enclosed, or otherwise protected by means of suitable covers, casings, barriers, rails, screens, mats, or platforms to remove the likelihood of approach or contact by persons or objects to a point of danger.

**Hazardous (Classified) Locations:** See Article 500.

**Header:** See Sections 356-1 and 358-2.

**Hermetic Refrigerant Motor-Compressor:** See Section 440-2.

**Hoistway:** Any shaftway, hatchway, well hole, or other vertical opening or space in which an elevator or dumbwaiter is designed to operate.

**Identified:** (As applied to Equipment.) Recognizable as suitable for the specific purpose, function, use, environment, application, etc.; where described in a particular Code requirement. (See "Equipment.")

(FPN): Suitability of equipment for a specific purpose, environment, or application may be determined by a qualified testing laboratory, inspection agency, or other organization concerned with product evaluation. Such identification may include labeling or listing: see "Labeled," "Listed," and Section 90-6.

**Individual Branch Circuit:** See "Branch Circuit, Individual."

**In Sight From (Within Sight From, Within Sight):** Where this Code specifies that one equipment shall be "in sight from," "within sight from," or "within sight," etc., of another equipment, one of the equipments specified is to be visible and not more than 50 feet (15.24 m) distant from the other.

**Insulated Conductor:** See under "Conductor."

**Intermittent Duty:** See under "Duty."

**Interrupting Rating:** The highest current at rated voltage that a device is intended to interrupt under standard test conditions.

(FPN): Equipment intended to break current at other than fault levels may have its interrupting rating implied in other ratings, such as horsepower or locked rotor current.

**Isolated:** Not readily accessible to persons unless special means for access are used.

**Labeled:** Equipment or materials to which has been attached a label, symbol, or other identifying mark of an organization acceptable to the authority having jurisdiction and concerned with product evaluation, that maintains periodic inspection of production of labeled equipment or materials and by whose labeling the manufacturer indicates compliance with appropriate standards or performance in a specified manner.

**Lighting Outlet:** An outlet intended for the direct connection of a lampholder, a lighting fixture, or a pendant cord terminating in a lampholder.

**Listed:** Equipment or materials included in a list published by an organization acceptable to the authority having jurisdiction and concerned with product evaluation, that maintains periodic inspection of production of listed equipment or materials, and whose listing states either that the equipment or material meets appropriate standards or has been tested and found suitable for use in a specified manner.

(FPN): The means for identifying listed equipment may vary for each organization concerned with product evaluation, some of which do not recognize equipment as listed unless it is also labeled. The authority having jurisdiction should utilize the system employed by the listing organization to identify a listed product.

**Location:**

**Damp Location:** Partially protected locations under canopies, marquees, roofed open porches, and like locations, and interior locations subject to moderate degrees of moisture, such as some basements, some barns, and some cold-storage warehouses.

**Dry Location:** A location not normally subject to dampness or wetness. A location classified as dry may be temporarily subject to dampness or wetness, as in the case of a building under construction.

**Wet Location:** Installations underground or in concrete slabs or masonry in direct contact with the earth, and locations subject to saturation with water or other liquids, such as vehicle washing areas, and locations exposed to weather and unprotected.

**Multioutlet Assembly:** A type of surface or flush raceway designed to hold conductors and receptacles, assembled in the field or at the factory.

**Multiwire Branch Circuit:** See "Branch Circuit, Multiwire."

**Neutral Conductor:** See Note 10 to Tables 310-16 through 310-31.

**Nonautomatic:** Action requiring personal intervention for its control. (See "Automatic.")

(FPN): As applied to an electric controller, nonautomatic control does not necessarily imply a manual controller, but only that personal intervention is necessary.

**Outlet:** A point on the wiring system at which current is taken to supply utilization equipment.

**Outline Lighting:** An arrangement of incandescent lamps or electric discharge tubing to outline or call attention to certain features such as the shape of a building or the decoration of a window.

**Oven, Wall-Mounted:** An oven for cooking purposes designed for mounting in or on a wall or other surface and consisting of one or more heating elements, internal wiring, and built-in or separately mountable controls. (See "Cooking Unit, Counter-Mounted.")

**Overcurrent:** Any current in excess of the rated current of equipment or the ampacity of a conductor. It may result from overload (see definition), short circuit, or ground fault.

(FPN): A current in excess of rating may be accommodated by certain equipment and conductors for a given set of conditions. Hence the rules for overcurrent protection are specific for particular situations.

**Overload:** Operation of equipment in excess of normal, full-load rating, or of a conductor in excess of rated ampacity which, when it persists for a sufficient length of time, would cause damage or dangerous overheating. A fault, such as a short circuit or ground fault, is not an overload. (See "Overcurrent.")

(FPN): For motor apparatus applications, see Section 430-31.

**Panelboard:** A single panel or group of panel units designed for assembly in the form of a single panel; including buses, automatic overcurrent devices, and with or without switches for the control of light, heat, or power circuits; designed to be placed in a cabinet or cutout box placed in or against a wall or partition and accessible only from the front. (See "Switchboard.")

**Periodic Duty:** See under "Duty."

**Power Outlet:** An enclosed assembly which may include receptacles, circuit breakers, fuseholders, fused switches, buses, and watt-hour meter mounting means; intended to supply and control power to mobile homes, recreational vehicles, or boats; or to serve as a means for distributing power required to operate mobile or temporarily installed equipment.

**Premises Wiring (System):** That interior and exterior wiring, including power, lighting, control, and signal circuit wiring together with all of its associated hardware, fittings, and wiring devices, both permanently and temporarily installed, which extends from the load end of the service drop, or load end of the service lateral conductors to the outlet(s). Such wiring does not include wiring internal to appliances, fixtures, motors, controllers, motor control centers, and similar equipment.

**Projector, Nonprofessional:** See Section 540-3.

**Projector, Professional:** See Section 540-2.

**Qualified Person:** One familiar with the construction and operation of the equipment and the hazards involved.

**Raceway:** An enclosed channel designed expressly for holding wires, cables, or busbars, with additional functions as permitted in this Code.

(FPN): Raceways may be of metal or insulating material, and the term includes rigid metal conduit, rigid nonmetallic conduit, intermediate metal conduit, liquidtight flexible metal conduit, flexible metallic tubing, flexible metal conduit, electrical nonmetallic tubing, electrical metallic tubing, underfloor raceways, cellular concrete floor raceways, cellular metal floor raceways, surface raceways, wireways, and busways.

**Rainproof:** So constructed, protected, or treated as to prevent rain from interfering with the successful operation of the apparatus under specified test conditions.

**Raintight:** So constructed or protected that exposure to a beating rain will not result in the entrance of water under specified test conditions.

**Rated-Load Current:** See Section 440-4(a), Definition.

**Readily Accessible:** (See "Accessible, Readily.")

**Receptacle:** A receptacle is a contact device installed at the outlet for the connection of a single attachment plug.

(FPN): A single receptacle is a single contact device with no other contact device on the same yoke. A multiple receptacle is a single device containing two or more receptacles.

**Receptacle Outlet:** An outlet where one or more receptacles are installed.

**Remote-Control Circuit:** Any electric circuit that controls any other circuit through a relay or an equivalent device.

**Sealable Equipment:** Equipment enclosed in a case or cabinet that is provided with a means of sealing or locking so that live parts cannot be made accessible without opening the enclosure. The equipment may or may not be operable without opening the enclosure.

**Separately Derived System:** See Section 250-5(d).

**Service:** The conductors and equipment for delivering energy from the electricity supply system to the wiring system of the premises served.

**Service Cable:** Service conductors made up in the form of a cable.

**Service Conductors:** The supply conductors that extend from the street main or from transformers to the service equipment of the premises supplied.

**Service Drop:** The overhead service conductors from the last pole or other aerial support to and including the splices, if any, connecting to the service-entrance conductors at the building or other structure.



**Service-Entrance Conductors, Overhead System:** The service conductors between the terminals of the service equipment and a point usually outside the building, clear of building walls, where joined by tap or splice to the service drop.

**Service-Entrance Conductors, Underground System:** The service conductors between the terminals of the service equipment and the point of connection to the service lateral.

(FPN): Where service equipment is located outside the building walls, there may be no service-entrance conductors, or they may be entirely outside the building.

**Service Equipment:** The necessary equipment, usually consisting of a circuit breaker or switch and fuses, and their accessories, located near the point of entrance of supply conductors to a building or other structure, or an otherwise defined area, and intended to constitute the main control and means of cutoff of the supply.

**Service Lateral:** The underground service conductors between the street main, including any risers at a pole or other structure or from transformers, and the first point of connection to the service-entrance conductors in a terminal box or meter or other enclosure with adequate space, inside or outside the building wall. Where there is no terminal box, meter, or other enclosure with adequate space, the point of connection shall be considered to be the point of entrance of the service conductors into the building.

**Service Raceway:** The raceway that encloses the service-entrance conductors.

**Setting (of Circuit Breaker):** See under "Circuit Breaker."

**Short-Time Duty:** See under "Duty."

**Show Window:** Any window used or designed to be used for the display of goods or advertising material, whether it is fully or partly enclosed or entirely open at the rear and whether or not it has a platform raised higher than the street floor level.

**Sign:** See "Electric Sign."

**Signaling Circuit:** Any electric circuit that energizes signaling equipment.

**Solar Photovoltaic System:** The total components and subsystems which in combination convert solar energy into electrical energy suitable for connection to a utilization load.

**Special Permission:** The written consent of the authority having jurisdiction.

**Switchboard:** A large single panel, frame, or assembly of panels on which are mounted, on the face or back or both, switches, overcurrent and other protective devices, buses, and usually instruments. Switchboards are generally accessible from the rear as well as from the front and are not intended to be installed in cabinets. (See "Panelboard.")

**Switches:**

**General-Use Switch:** A switch intended for use in general distribution and branch circuits. It is rated in amperes, and it is capable of interrupting its rated current at its rated voltage.

**General-Use Snap Switch:** A form of general-use switch so constructed that it can be installed in flush device boxes or on outlet box covers,

or otherwise used in conjunction with wiring systems recognized by this Code.

**AC General-Use Snap Switch:** See Section 380-14(a).

**AC-DC General-Use Snap Switch:** See Section 380-14(b).

**Isolating Switch:** A switch intended for isolating an electric circuit from the source of power. It has no interrupting rating, and it is intended to be operated only after the circuit has been opened by some other means.

**Motor-Circuit Switch:** A switch, rated in horsepower, capable of interrupting the maximum operating overload current of a motor of the same horsepower rating as the switch at the rated voltage.

**Thermal Cutout:** An overcurrent protective device that contains a heater element in addition to and affecting a renewable fusible member which opens the circuit. It is not designed to interrupt short-circuit currents.

**Thermally Protected:** (As applied to motors.) The words "Thermally Protected" appearing on the nameplate of a motor or motor-compressor indicate that the motor is provided with a thermal protector.

**Thermal Protector:** (As applied to motors.) A protective device for assembly as an integral part of a motor or motor-compressor and which, when properly applied, protects the motor against dangerous overheating due to overload and failure to start.

(FPN): The thermal protector may consist of one or more sensing elements integral with the motor or motor-compressor and an external control device.

**Utilization Equipment:** Equipment which utilizes electric energy for mechanical, chemical, heating, lighting, or similar purposes.

**Varying Duty:** See under "Duty."

**Ventilated:** Provided with a means to permit circulation of air sufficient to remove an excess of heat, fumes, or vapors.

**Volatile Flammable Liquid:** A flammable liquid having a flash point below 38°C (100°F), or a flammable liquid whose temperature is above its flash point, or a Class II combustible liquid having a vapor pressure not exceeding 40 psia (276 kPa) at 38°C (100°F) whose temperature is above its flash point.

**Voltage (of a Circuit):** The greatest root-mean-square (effective) difference of potential between any two conductors of the circuit concerned.

(FPN): Some systems, such as 3-phase 4-wire, single-phase 3-wire, and 3-wire direct-current may have various circuits of various voltages.

**Voltage, Nominal:** A nominal value assigned to a circuit or system for the purpose of conveniently designating its voltage class (as 120/240, 480Y/277, 600, etc.).

The actual voltage at which a circuit operates can vary from the nominal within a range that permits satisfactory operation of equipment.

(FPN): See "Voltage Ratings for Electric Power Systems and Equipment (60 Hz)," ANSI C84.1-1982.

**Voltage to Ground:** For grounded circuits, the voltage between the given conductor and that point or conductor of the circuit that is grounded; for ungrounded circuits, the greatest voltage between the given conductor and any other conductor of the circuit.

**Watertight:** So constructed that moisture will not enter the enclosure under specified test conditions.

(FPN): For test conditions other than for rotating equipment, see NEMA standards Publication No. 250-1979 - Enclosure for Electrical Equipment (1000 Volts Maximum) Section 250-5.07, Hosedown Test.

**Weatherproof:** So constructed or protected that exposure to the weather will not interfere with successful operation.

(FPN): Rainproof, raintight, or watertight equipment can fulfill the requirements for weatherproof where varying weather conditions other than wetness, such as snow, ice, dust, or temperature extremes, are not a factor.

**Welder, Electric:**

Actual Primary Current: See Section 630-31(b).

Rated Primary Current: See Section 630-31(b).

**Wet Location:** See under "Location."

**X-ray:**

Long-Time Rating: See Sections 517-140 and 660-2.

Momentary Rating: See Sections 517-140 and 660-2.

## B. Over 600 Volts, Nominal

Whereas the preceding definitions are intended to apply wherever the terms are used throughout this Code, the following ones are applicable only to the parts of articles specifically covering installations and equipment operating at over 600 volts, nominal.

**Circuit Breaker:** See under "Switching Devices."

**Cutout:** See under "Switching Devices."

**Disconnect (Isolator):** See under "Switching Devices."

**Disconnecting Means:** See under "Switching Devices."

**Fuse:** An overcurrent protective device with a circuit opening fusible part that is heated and severed by the passage of overcurrent through it.

(FPN): A fuse comprises all the parts that form a unit capable of performing the prescribed functions. It may or may not be the complete device necessary to connect it into an electrical circuit.

**Expulsion Fuse Unit (Expulsion Fuse):** A vented fuse unit in which the expulsion effect of gases produced by the arc and lining of the fuseholder, either alone or aided by a spring, extinguishes the arc.

**Power Fuse Unit:** A vented, nonvented or controlled vented fuse unit in which the arc is extinguished by being drawn through solid material, granular material, or liquid, either alone or aided by a spring.

**Vented Power Fuse:** A fuse with provision for the escape of arc gases, liquids, or solid particles to the surrounding atmosphere during circuit interruption.

**Nonvented Power Fuse:** A fuse without intentional provision for the escape of arc gases, liquids, or solid particles to the atmosphere during circuit interruption.

**Controlled Vented Power Fuse:** A fuse with provision for controlling discharge circuit interruption such that no solid material may be exhausted into the surrounding atmosphere.

(FPN): The fuse is designed so that discharged gases will not ignite or damage insulation in the path of the discharge or propagate a flashover to or between grounded members or conduction members in the path of the discharge when the

distance between the vent and such insulation or conduction members conforms to manufacturer's recommendations.

**Grounded, Effectively:** Permanently connected to earth through a ground connection of sufficiently low impedance and having sufficient ampacity that ground-fault current which may occur cannot build up to voltages dangerous to personnel.

**Interrupter Switch:** See under "Switching Devices."

**Multiple Fuse:** An assembly of two or more single-pole fuses.

**Oil (Filled) Cutout:** See under "Switching Devices."

**Power Fuse:** See under "Fuse."

**Regulator Bypass Switch:** See under "Switching Devices."

**Switching Device:** A device designed to close and/or open one or more electric circuits.

**Switching Devices:**

**Circuit Breaker:** A switching device capable of making, carrying, and breaking currents under normal circuit conditions, and also making, carrying for a specified time, and breaking currents under specified abnormal circuit conditions, such as those of short circuit.

**Cutout:** An assembly of a fuse support with either a fuseholder, fuse carrier, or disconnecting blade. The fuseholder or fuse carrier may include a conducting element (fuse link), or may act as the disconnecting blade by the inclusion of a nonfusible member.

**Disconnecting (or Isolating) Switch (Disconnecter, Isolator):** A mechanical switching device used for isolating a circuit or equipment from a source of power.

**Disconnecting Means:** A device, group of devices, or other means whereby the conductors of a circuit can be disconnected from their source of supply.

**Interrupter Switch:** A switch capable of making, carrying, and interrupting specified currents.

**Oil Cutout (Oil-Filled Cutout):** A cutout in which all or part of the fuse support and its fuse link or disconnecting blade are mounted in oil with complete immersion of the contacts and the fusible portion of the conducting element (fuse link), so that arc interruption by severing of the fuse link or by opening of the contacts will occur under oil.

**Oil Switch:** An oil switch is a switch having contacts which operate under oil (or askarel or other suitable liquid).

**Regulator Bypass Switch:** A specific device or combination of devices designed to bypass a regulator.

## ARTICLE 110 — REQUIREMENTS FOR ELECTRICAL INSTALLATIONS

### A. General

**110-1. Mandatory Rules and Explanatory Material.** Mandatory rules of this Code are characterized by the use of the word "shall." Explanatory material is in the form of Fine Print Notes (FPN).

**110-2. Approval.** The conductors and equipment required or permitted by this Code shall be acceptable only if approved.

(FPN): See Examination of Equipment for Safety, Section 90-6 and Examination, Identification, Installation, and Use of Equipment, Section 110-3. See definitions of "Approved," "Identified," "Labeled," and "Listed."

**110-3. Examination, Identification, Installation, and Use of Equipment.**

(a) **Examination.** In judging equipment, considerations such as the following shall be evaluated:

(1) Suitability for installation and use in conformity with the provisions of this Code. Suitability of equipment use may be identified by a description marked on or provided with a product to identify the suitability of the product for a specific purpose, environment, or application. Suitability of equipment may be evidenced by listing or labeling.

(2) Mechanical strength and durability, including, for parts designed to enclose and protect other equipment, the adequacy of the protection thus provided.

(3) Wire-bending and connection space.

(4) Electrical insulation.

(5) Heating effects under normal conditions of use and also under abnormal conditions likely to arise in service.

(6) Arcing effects.

(7) Classification by type, size, voltage, current capacity, specific use.

(8) Other factors which contribute to the practical safeguarding of persons using or likely to come in contact with the equipment.

(b) **Installation and Use.** Listed or labeled equipment shall be used or installed in accordance with any instructions included in the listing or labeling.

**110-4. Voltages.** Throughout this Code the voltage considered shall be that at which the circuit operates.

**110-5. Conductors.** Conductors normally used to carry current shall be of copper unless otherwise provided in this Code. Where the conductor material is not specified, the sizes given in this Code shall apply to copper conductors. Where other materials are used, the size shall be changed accordingly.

(FPN): For aluminum and copper-clad aluminum conductors, see Tables 310-16 through 310-31.

**110-6. Conductor Sizes.** Conductor sizes are expressed in American Wire Gage (AWG) or in circular mils.

**110-7. Insulation Integrity.** All wiring shall be so installed that when completed the system will be free from short circuits and from grounds other than as permitted in Article 250.

**110-8. Wiring Methods.** Only wiring methods recognized as suitable are included in this Code. The recognized methods of wiring shall be permitted to be installed in any type of building or occupancy, except as otherwise provided in this Code.

**110-9. Interrupting Rating.** Equipment intended to break current at fault levels shall have an interrupting rating sufficient for the system voltage and the current which is available at the line terminals of the equipment.

Equipment intended to break current at other than fault levels shall have an interrupting rating at system voltage sufficient for the current that must be interrupted.

**110-10. Circuit Impedance and Other Characteristics.** The overcurrent protective devices, the total impedance, the component short-circuit withstand ratings, and other characteristics of the circuit to be protected shall be so selected and coordinated as to permit the circuit protective devices used to clear a fault without the occurrence of extensive damage to the electrical components of the circuit. This fault shall be assumed to be either between two or more of the circuit conductors, or between any circuit conductor and the grounding conductor or enclosing metal raceway.

**110-11. Deteriorating Agents.** Unless identified for use in the operating environment, no conductors or equipment shall be located in damp or wet locations; where exposed to gases, fumes, vapors, liquids, or other agents having a deteriorating effect on the conductors or equipment; nor where exposed to excessive temperatures.

(FPN): See Section 300-6 for protection against corrosion.

Control equipment, utilization equipment, and busways approved for use in dry locations only shall be protected against permanent damage from the weather during building construction.

**110-12. Mechanical Execution of Work.** Electric equipment shall be installed in a neat and workmanlike manner.

(a) **Unused Openings.** Unused openings in boxes, raceways, auxiliary gutters, cabinets, equipment cases or housings shall be effectively closed to afford protection substantially equivalent to the wall of the equipment.

(b) **Subsurface Enclosures.** Conductors shall be racked to provide ready and safe access in underground and subsurface enclosures, into which persons enter for installation and maintenance.

**110-13. Mounting and Cooling of Equipment.**

(a) **Mounting.** Electric equipment shall be firmly secured to the surface on which it is mounted. Wooden plugs driven into holes in masonry, concrete, plaster, or similar materials shall not be used.

(b) **Cooling.** Electrical equipment which depends upon the natural circulation of air and convection principles for cooling of exposed surfaces shall be installed so that room air flow over such surfaces is not prevented by walls or by adjacent installed equipment. For equipment designed for floor mounting,

clearance between top surfaces and adjacent surfaces shall be provided to dissipate rising warm air.

Electrical equipment provided with ventilating openings shall be installed so that walls or other obstructions do not prevent the free circulation of air through the equipment.

**110-14. Electrical Connections.** Because of different characteristics of copper and aluminum, devices such as pressure terminal or pressure splicing connectors and soldering lugs shall be suitable for the material of the conductor and shall be properly installed and used. Conductors of dissimilar metals shall not be intermixed in a terminal or splicing connector where physical contact occurs between dissimilar conductors (such as copper and aluminum, copper and copper-clad aluminum, or aluminum and copper-clad aluminum), unless the device is suitable for the purpose and conditions of use. Materials such as solder, fluxes, inhibitors, and compounds, where employed, shall be suitable for the use and shall be of a type which will not adversely affect the conductors, installation, or equipment.

(FPN): Many terminations and equipment are marked with a tightening torque.

(a) **Terminals.** Connection of conductors to terminal parts shall ensure a thoroughly good connection without damaging the conductors and shall be made by means of pressure connectors (including set-screw type), solder lugs, or splices to flexible leads.

*Exception: Connection by means of wire binding screws or studs and nuts having upturned lugs or equivalent shall be permitted for No. 10 or smaller conductors.*

Terminals for more than one conductor and terminals used to connect aluminum shall be so identified.

(b) **Splices.** Conductors shall be spliced or joined with splicing devices suitable for the use or by brazing, welding, or soldering with a fusible metal or alloy. Soldered splices shall first be so spliced or joined as to be mechanically and electrically secure without solder and then soldered. All splices and joints and the free ends of conductors shall be covered with an insulation equivalent to that of the conductors or with an insulating device suitable for the purpose.

**110-16. Working Space About Electric Equipment (600 Volts, Nominal, or Less).** Sufficient access and working space shall be provided and maintained about all electric equipment to permit ready and safe operation and maintenance of such equipment.

(a) **Working Clearances.** Except as elsewhere required or permitted in this Code, the dimension of the working space in the direction of access to live parts operating at 600 volts, nominal, or less and likely to require examination, adjustment, servicing, or maintenance while energized shall not be less than indicated in Table 110-16(a). Distances shall be measured from the live parts if such are exposed or from the enclosure front or opening if such are enclosed. Concrete, brick, or tile walls shall be considered as grounded.

In addition to the dimensions shown in Table 110-16(a), the work space shall not be less than 30 inches (762 mm) wide in front of the electric equipment. In all cases the work space shall permit at least a 90-degree opening of equipment doors or hinged panels.

Table 110-16(a). Working Clearances

Voltage to Ground, Nominal	Condition:	Minimum Clear Distance (feet)		
		1	2	3
0-150		3	3	3
151-600		3	3½	4

For SI units: one inch = 25.4 millimeters; one foot = 0.3048 meter.

**Where the "Conditions" are as follows:**

1. Exposed live parts on one side and no live or grounded parts on the other side of the working space, or exposed live parts on both sides effectively guarded by suitable wood or other insulating materials. Insulated wire or insulated busbars operating at not over 300 volts shall not be considered live parts.

2. Exposed live parts on one side and grounded parts on the other side.

3. Exposed live parts on both sides of the work space (not guarded as provided in Condition 1) with the operator between.

*Exception No. 1: Working space shall not be required in back of assemblies such as dead-front switchboards, or motor control centers where there are no renewable or adjustable parts such as fuses or switches on the back and where all connections are accessible from locations other than the back.*

*Exception No. 2: By special permission smaller spaces may be permitted (1) where it is judged that the particular arrangement of the installation will provide adequate accessibility, or (2) where all uninsulated parts are at a voltage no greater than 30 volts RMS or 42V dc.*

**(b) Clear Spaces.** Working space required by this section shall not be used for storage. When normally enclosed live parts are exposed for inspection or servicing, the working space, if in a passageway or general open space, shall be suitably guarded.

**(c) Access and Entrance to Working Space.** At least one entrance of sufficient area shall be provided to give access to the working space about electric equipment.

For switchboards and control panels rated 1200 amperes or more and over 6 feet (1.83 m) wide, there shall be one entrance not less than 24 inches (610 mm) wide and 6 ½ feet (1.98 m) high at each end.

*Exception No. 1: Where the switchboards and panelboards location permits a continuous and unobstructed way of exit travel.*

*Exception No. 2: Where the work space required by Section 110-16(a) is doubled, only one entrance to the working space is required.*

Working space with one entrance provided shall be so located that the edge of the entrance nearest the switchboards and panelboards is the minimum clear distance given in Table 110-16(a) away from such equipment.

**(d) Front Working Space.** In all cases where there are live parts normally exposed on the front of switchboards or motor control centers, the working space in front of such equipment shall not be less than 3 feet (914 mm).



(e) **Illumination.** Illumination shall be provided for all working spaces about service equipment, switchboards, panelboards, or motor control centers installed indoors.

*Exception: Service equipment or panelboards, in dwelling units, that do not exceed 200 amperes.*

(f) **Headroom.** The minimum headroom of working spaces about service equipment, switchboards, panelboards, or motor control centers shall be 6 1/4 feet (1.91 m).

*Exception: Service equipment or panelboards, in dwelling units, that do not exceed 200 amperes.*

(FPN): For higher voltages, see Article 710.

(FPN): As used in this section, a motor control center is an assembly of one or more enclosed sections having a common power bus and principally containing motor control units.

### 110-17. Guarding of Live Parts (600 Volts, Nominal, or Less).

(a) **Live Parts Guarded Against Accidental Contact.** Except as elsewhere required or permitted by this Code, live parts of electric equipment operating at 50 volts or more shall be guarded against accidental contact by approved enclosures or by any of the following:

(1) By location in a room, vault, or similar enclosure that is accessible only to qualified persons.

(2) By suitable permanent, substantial partitions or screens so arranged that only qualified persons will have access to the space within reach of the live parts. Any openings in such partitions or screens shall be so sized and located that persons are not likely to come into accidental contact with the live parts or to bring conducting objects into contact with them.

(3) By location on a suitable balcony, gallery, or platform so elevated and arranged as to exclude unqualified persons.

(4) By elevation of 8 feet (2.44 m) or more above the floor or other working surface.

(b) **Prevent Physical Damage.** In locations where electric equipment would be exposed to physical damage, enclosures or guards shall be so arranged and of such strength as to prevent such damage.

(c) **Warning Signs.** Entrances to rooms and other guarded locations containing exposed live parts shall be marked with conspicuous warning signs forbidding unqualified persons to enter.

(FPN): For motors, see Sections 430-132 and 430-133. For over 600 volts, see Section 110-34.

**110-18. Arcing Parts.** Parts of electric equipment which in ordinary operation produce arcs, sparks, flames, or molten metal shall be enclosed or separated and isolated from all combustible material.

(FPN): For hazardous (classified) locations, see Articles 500 through 517. For motors, see Section 430-14.

**110-19. Light and Power from Railway Conductors.** Circuits for lighting and power shall not be connected to any system containing trolley wires with a ground return.

*Exception: Car houses, power houses, or passenger and freight stations operated in connection with electric railways.*

**110-21. Marking.** The manufacturer's name, trademark, or other descriptive marking by which the organization responsible for the product may be identified shall be placed on all electric equipment. Other markings shall be provided giving voltage, current, wattage, or other ratings as are specified elsewhere in this Code. The marking shall be of sufficient durability to withstand the environment involved.

**110-22. Identification of Disconnecting Means.** Each disconnecting means required by this Code for motors and appliances, and each service, feeder, or branch circuit at the point where it originates shall be legibly marked to indicate its purpose unless located and arranged so the purpose is evident. The marking shall be of sufficient durability to withstand the environment involved.

## B. Over 600 Volts, Nominal

**110-30. General.** Conductors and equipment used on circuits over 600 volts, nominal, shall comply with all applicable provisions of the preceding sections of this article and with the following sections, which supplement or modify the preceding sections. In no case shall the provisions of this part apply to equipment on the supply side of the service conductors.

**110-31. Enclosure for Electrical Installations.** Electrical installations in a vault, room, or closet or in an area surrounded by a wall, screen, or fence, access to which is controlled by lock and key or other approved means, shall be considered to be accessible to qualified persons only. The type of enclosure used in a given case shall be designed and constructed according to the nature and degree of the hazard(s) associated with the installation.

A wall, screen, or fence less than 8 feet (2.44 m) in height shall not be considered as preventing access unless it has other features that provide a degree of isolation equivalent to an 8-foot (2.44-m) fence.

(FPN): Article 450 covers minimum construction requirements for transformer vaults.

(FPN): Isolation by elevation is covered in paragraph (b) of this section and in Section 110-34.

### (a) Indoor Installations.

**(1) In Places Accessible to Unqualified Persons.** Indoor electrical installations that are open to unqualified persons shall be made with metal-enclosed equipment or shall be enclosed in a vault or in an area access to which is controlled by a lock. Metal-enclosed switchgear, unit substations, transformers, pull boxes, connection boxes, and other similar associated equipment shall be marked with appropriate caution signs. Openings in ventilated dry-type transformers or similar openings in other equipment shall be designed so that foreign objects inserted through these openings will be deflected from energized parts.

**(2) In Places Accessible to Qualified Persons Only.** Indoor electrical installations considered accessible to qualified persons only in accordance with this section shall comply with Sections 110-34, 710-32, and 710-33.

**(b) Outdoor Installations.**

**(1) In Places Accessible to Unqualified Persons.** Outdoor electrical installations that are open to unqualified persons shall comply with Article 225.

(FPN): For clearances of conductors for system voltages over 600 volts, nominal, see National Electrical Safety Code (ANSI C2-1984).

**(2) In Places Accessible to Qualified Persons Only.** Outdoor electrical installations having exposed live parts shall be accessible to qualified persons only in accordance with the first paragraph of this section and shall comply with Sections 110-34, 710-32, and 710-33.

**(c) Metal-Enclosed Equipment Accessible to Unqualified Persons.** Ventilating or similar openings in equipment shall be so designed that foreign objects inserted through these openings will be deflected from energized parts. When exposed to physical damage from vehicular traffic suitable guards shall be provided. Metal-enclosed equipment located outdoors accessible to the general public shall be designed so that exposed nuts or bolts cannot be readily removed, permitting access to live parts. Where metal-enclosed equipment is accessible to the general public and the bottom of the enclosure is less than 8 feet (2.44 m) above the floor or grade level, the enclosure door or hinged cover shall be kept locked.

**110-32. Work Space about Equipment.** Sufficient space shall be provided and maintained about electric equipment to permit ready and safe operation and maintenance of such equipment. Where energized parts are exposed, the minimum clear work space shall not be less than 6 ½ feet (1.98 m) high (measured vertically from the floor or platform), or less than 3 feet (914 mm) wide (measured parallel to the equipment). The depth shall be as required in Section 110-34(a). In all cases, the work space shall be adequate to permit at least a 90-degree opening of doors or hinged panels.

**110-33. Entrance and Access to Work Space.**

**(a) Entrance.** At least one entrance not less than 24 inches (610 mm) wide and 6 ½ feet (1.98 m) high shall be provided to give access to the working space about electric equipment.

On switchboard and control panels exceeding 6 feet (1.83 m) in width, there shall be one entrance at each end of such board.

*Exception No. 1: Where the switchboards and panelboards location permits a continuous and unobstructed way of exit travel.*

*Exception No. 2: Where the work space required in Section 110-34(a) is doubled.*

Working space with one entrance provided shall be so located that the edge of the entrance nearest the switchboards and panelboards is the minimum clear distance given in Table 110-34(a) away from such equipment.

Where bare energized parts at any voltage or insulated energized parts above 600 volts, nominal, are located adjacent to such entrance, they shall be suitably guarded.

**(b) Access.** Permanent ladders or stairways shall be provided to give safe access to the working space around electric equipment installed on platforms, balconies, mezzanine floors, or in attic or roof rooms or spaces.

**110-34. Work Space and Guarding.**

(a) **Working Space.** The minimum clear working space in front of electric equipment such as switchboards, control panels, switches, circuit breakers, motor controllers, relays, and similar equipment shall not be less than specified in Table 110-34(a) unless otherwise specified in this Code. Distances shall be measured from the live parts if such are exposed, or from the enclosure front or opening if such are enclosed.

**Table 110-34(a)**  
**Minimum Depth of Clear Working Space in Front of Electric Equipment**

Nominal Voltage to Ground	Conditions		
	1	2	3
	(Feet)	(Feet)	(Feet)
601-2500	3	4	5
2501-9000	4	5	6
9001-25,000	5	6	9
25,001-75 kV	6	8	10
Above 75 kV	8	10	12

For SI units: one foot = 0.3048 meter.

**Where the "Conditions" are as follows:**

1. Exposed live parts on one side and no live or grounded parts on the other side of the working space or exposed live parts on both sides effectively guarded by suitable wood or other insulating materials. Insulated wire or insulated busbars operating at not over 300 volts shall not be considered live parts.
2. Exposed live parts on one side and grounded parts on the other side. Concrete, brick, or tile walls will be considered as grounded surfaces.
3. Exposed live parts on both sides of the work space (not guarded as provided in Condition 1) with the operator between.

*Exception: Working space is not required in back of equipment such as dead-front switchboards or control assemblies where there are no renewable or adjustable parts (such as fuses or switches) on the back and where all connections are accessible from locations other than the back. Where rear access is required to work on de-energized parts on the back of enclosed equipment, a minimum working space of 30 inches (762 mm) horizontally shall be provided.*

(b) **Separation from Low-Voltage Equipment.** Where switches, cutouts, or other equipment operating at 600 volts, nominal, or less, are installed in a room or enclosure where there are exposed live parts or exposed wiring operating at over 600 volts, nominal, the high-voltage equipment shall be effectively separated from the space occupied by the low-voltage equipment by a suitable partition, fence, or screen.

*Exception: Switches or other equipment operating at 600 volts, nominal, or less, and serving only equipment within the high-voltage vault, room, or*

enclosure shall be permitted to be installed in the high-voltage enclosure, room, or vault if accessible to qualified persons only.

**(c) Locked Rooms or Enclosures.** The entrances to all buildings, rooms, or enclosures containing exposed live parts or exposed conductors operating at over 600 volts, nominal, shall be kept locked.

*Exception: Where such entrances are under the observation of a qualified person at all times.*

Where the voltage exceeds 600 volts, nominal, permanent and conspicuous warning signs shall be provided, reading substantially as follows: "Warning—High Voltage—Keep Out."

**(d) Illumination.** Adequate illumination shall be provided for all working spaces about electrical equipment. The lighting outlets shall be so arranged that persons changing lamps or making repairs on the lighting system will not be endangered by live parts or other equipment.

The points of control shall be so located that persons are not likely to come in contact with any live part or moving part of the equipment while turning on the lights.

**(e) Elevation of Unguarded Live Parts.** Unguarded live parts above working space shall be maintained at elevations not less than required by Table 110-34(e).

**Table 110-34(e)**  
**Elevation of Unguarded Live Parts above Working Space**

Nominal Voltage Between Phases	Elevation
601-7500	8'6"
7501-35000	9'
Over 35kV	9'+0.37" per kV above 35

For SI units: one inch = 25.4 millimeters; one foot = 0.3048 meter.

## Chapter 2. Wiring Design and Protection

### ARTICLE 200 — USE AND IDENTIFICATION OF GROUNDED CONDUCTORS

**200-1. Scope.** This article provides requirements for: (1) identification of terminals; (2) grounded conductors in premises wiring systems; and (3) identification of grounded conductors.

(FPN): See Article 100 for definitions of "Grounded Conductor" and "Grounding Conductor."

**200-2. General.** All premises wiring systems shall have a grounded conductor that is identified in accordance with Section 200-6.

*Exception: Circuits and systems exempted or prohibited by Sections 210-10, 215-7, 250-3, 250-5, 250-7, 503-13, 517-104, 668-11, 668-21, and 690-41*  
*Exception.*

The grounded conductor, when insulated, shall have insulation: (1) which is suitable, other than color, for any ungrounded conductor of the same circuit on circuits of less than 1000 volts, or (2) rated not less than 600 volts for solidly grounded neutral systems of 1 kV and over as described in Section 250-152(a).

**200-3. Connection to Grounded System.** Premises wiring shall not be electrically connected to a supply system unless the latter contains, for any grounded conductor of the interior system, a corresponding conductor which is grounded.

For the purpose of this section, "electrically connected" shall mean connection capable of carrying current as distinguished from connection through electromagnetic induction.

**200-6. Means of Identifying Grounded Conductors.**

(a) **Sizes No. 6 or Smaller.** An insulated grounded conductor of No. 6 or smaller shall be identified by a continuous white or natural gray outer finish along its entire length.

*Exception No. 1: Multiconductor varnished-cloth-insulated cables.*

*Exception No. 2: Fixture wires as outlined in Article 402.*

*Exception No. 3: A conductor identified as required by Section 210-5(a) for branch circuits.*

*Exception No. 4: Where the conditions of maintenance and supervision assure that only qualified persons will service the installation, grounded conductors in multiconductor cables shall be permitted to be permanently identified at their terminations at the time of installation by a distinctive white marking or other equally effective means.*

*Exception No. 5: The grounded conductor of a mineral-insulated, metal-sheathed cable shall be identified at the time of installation by distinctive marking at its terminations.*

For aerial cable, the identification shall be as above, or by means of a ridge so located on the exterior of the cable as to identify it.

Wires having their outer covering finished to show a white or natural gray color but having colored tracer threads in the braid, identifying the source of manufacture, shall be considered as meeting the provisions of this section.

**(b) Sizes Larger than No. 6.** An insulated grounded conductor larger than No. 6 shall be identified either by a continuous white or natural gray outer finish along its entire length or at the time of installation by a distinctive white marking at its terminations. Multiconductor flat cable No. 4 or larger shall be permitted to employ an external ridge on the grounded conductor.

*Exception: Where the conditions of maintenance and supervision assure that only qualified persons will service the installation, grounded conductors in multiconductor cables shall be permitted to be permanently identified at their terminations at the time of installation by a distinctive white marking or other equally effective means.*

**(c) Flexible Cords.** An insulated conductor intended for use as a grounded conductor, where contained within a flexible cord, shall be identified by a white or natural gray outer finish or by methods permitted by Section 400-22.

**(d) Grounded Conductors of Different Systems.** Where conductors of different systems are installed in the same raceway, box, auxiliary gutter, or other types of enclosures, one system grounded conductor, if required, shall have an outer covering conforming to (a) or (b) above. Each other system grounded conductor, if required, shall have an outer covering of white with an identifiable colored stripe (not green) running along the insulation, or other and different means of identification as allowed by (a) or (b).

**200-7. Use of White or Natural Gray Color.** A continuous white or natural gray covering on a conductor or a termination marking of white or natural gray color shall be used only for the grounded conductor.

*Exception No. 1: An insulated conductor with a white or natural gray finish shall be permitted as an ungrounded conductor where permanently reidentified to indicate its use, by painting or other effective means at its termination, and at each location where the conductor is visible and accessible.*

*Exception No. 2: A cable containing an insulated conductor with a white or natural gray outer finish shall be permitted for single-pole, 3-way, or 4-way switch loops where the white or natural gray conductor is used for the supply to the switch, but not as a return conductor from the switch to the switched outlet. In these applications, reidentification of the white or natural gray conductor shall not be required.*

*Exception No. 3: A flexible cord for connecting an appliance having one conductor identified with a white or natural gray outer finish, or by any other means permitted by Section 400-22, shall be permitted whether or not the outlet to which it is connected is supplied by a circuit having a grounded conductor.*

*Exception No. 4: A white or natural gray conductor of circuits of less than 50 volts shall be required to be grounded only as required by Section 250-5(a).*

**200-9. Means of Identification of Terminals.** The identification of terminals to which a grounded conductor is to be connected shall be substantially white in color. The identification of other terminals shall be of a readily distinguishable different color.

*Exception: Where the conditions of maintenance and supervision assure that only qualified persons will service the installations, terminals for grounded conductors shall be permitted to be permanently identified at the time of installation by a distinctive white marking or other equally effective means.*

**200-10. Identification of Terminals.**

**(a) Device Terminals.** All devices provided with terminals for the attachment of conductors and intended for connection to more than one side of the circuit shall have terminals properly marked for identification.

*Exception No. 1: Where the electrical connection of a terminal intended to be connected to the grounded conductor is clearly evident.*

*Exception No. 2: Single-pole devices to which only one side of the line is connected.*

*Exception No. 3: The terminals of lighting and appliance branch-circuit panelboards.*

*Exception No. 4: Devices having a normal current rating of over 30 amperes other than polarized attachment plugs and polarized receptacles for attachment plugs as required in (b) below.*

**(b) Receptacles, Plugs, and Connectors.** Receptacles, polarized attachment plugs and cord connectors for plugs and polarized plugs shall have the terminal intended for connection to the grounded (white) conductor identified.

Identification shall be by a metal or metal coating substantially white in color or the word "white" located adjacent to the identified terminal.

If the terminal is not visible, the conductor entrance hole for the connection shall be colored white or marked with the word "white."

The terminal for the connection of the equipment grounding conductor shall be identified by: (1) a green-colored, not readily removable terminal screw with a hexagonal head; (2) a green-colored, hexagonal, not readily removable terminal nut; or (3) a green-colored pressure wire connector. If the terminal for the grounding conductor is not visible, the conductor entrance hole shall be marked with the word "green" or otherwise identified by a distinctive green color.

*Exception: Terminal identification shall not be required for 2-wire nonpolarized attachment plugs.*

**(c) Screw Shells.** For devices with screw shells, the terminal for the grounded conductor shall be the one connected to the screw shell.

**(d) Screw-Shell Devices with Leads.** For screw-shell devices with attached leads, the conductor attached to the screw shell shall have a white or natural gray finish. The outer finish of the other conductor shall be of a solid color that will not be confused with the white or natural gray finish used to identify the grounded conductor.

**(e) Appliances.** Appliances that have a single-pole switch or a single-pole overcurrent device in the line or any line-connected screw-shell lampholders, and that are to be connected: (1) by permanent wiring methods; or (2) by



field-installed attachment plugs and cords with three or more wires (including the equipment grounding conductor) shall have means to identify the terminal for the grounded circuit conductor (if any).

**200-11. Polarity of Connections.** No grounded conductor shall be attached to any terminal or lead so as to reverse designated polarity.

## ARTICLE 210 — BRANCH CIRCUITS

### A. General Provisions

**210-1. Scope.** This article covers branch circuits except for branch circuits which supply only motor loads, which are covered in Article 430. Provisions of this article and Article 430 apply to branch circuits with combination loads.

*Exception: Branch circuits for electrolytic cells as covered in Section 668-3(c), Exceptions No. 1 and 4.*

**210-2. Other Articles for Specific-Purpose Branch Circuits.** Branch circuits shall comply with this article and also with the applicable provisions of other articles of this Code. The provisions for branch circuits supplying equipment in the following list amend or supplement the provisions in this article and shall apply to branch circuits referred to therein:

	Article	Section
Air-Conditioning and Refrigerating Equipment .....		440-6 440-31 440-32
Busways .....		364-9
Class 1, Class 2, and Class 3 Remote Control, Signaling, and Power-Limited Circuits .....	725	
Closed-Loop and Programmed Power Distribution Systems .....	780	
Cranes and Hoists .....		610-42
Electronic Computer/ Data Processing Equipment .....		645-2
Electric Signs and Outline Lighting .....		600-6
Electric Welders .....	630	
Elevators, Dumbwaiters, Escalators, and Moving Walks .....		620-61
Fire Protective Signaling Systems .....	760	
Fixed Electric Space Heating Equipment .....		424-3
Fixed Outdoor Electric De-icing and Snow- Melting Equipment .....		426-4
Infrared Lamp Industrial Heating Equipment .....		422-15 424-3
Induction and Dielectric Heating Equipment .....	665	

Marinas and Boatyards .....		555-4
Mobile Homes and Mobile Home Parks .....	550	
Motion Picture and Television Studios and Similar Locations .....	530	
Motors and Motor Controllers .....	430	
Organs .....		650-6
Recreational Vehicles and Recreational Vehicle Parks .....	551	
Sound Recording and Similar Equipment .....		640-6
Switchboards and Panelboards .....		384-22
Systems over 600 Volts, Nominal .....	710	
Systems under 50 Volts .....	720	
Theaters and Similar Locations .....		520-41 520-52 520-62
X-ray Equipment .....		660-2 517-143

**210-3. Classifications.** Branch circuits recognized by this article shall be classified in accordance with the maximum permitted ampere rating or setting of the overcurrent device. The classification for other than individual branch circuits shall be: 15, 20, 30, 40, and 50 amperes. Where conductors of higher ampacity are used for any reason, the ampere rating or setting of the specified overcurrent device shall determine the circuit classification.

*Exception: Multioutlet branch circuits greater than 50 amperes shall be permitted on industrial premises where maintenance and supervision indicate that qualified persons will service equipment.*

#### **210-4. Multiwire Branch Circuits.**

(a) **General.** Branch circuits recognized by this article shall be permitted as multiwire circuits. A multiwire branch circuit shall be permitted to be considered as multiple circuits. All conductors shall originate from the same panelboard.

(b) **Dwelling Units.** In dwelling units a multiwire branch circuit supplying more than one device or equipment on the same yoke shall be provided with a means to disconnect simultaneously all ungrounded conductors at the panelboard where the branch circuit originated.

(c) **Line to Neutral Load.** Multiwire branch circuits shall supply only line to neutral load.

*Exception No. 1: A multiwire branch circuit that supplies only one utilization equipment.*

*Exception No. 2: Where all ungrounded conductors of the multiwire branch circuit are opened simultaneously by the branch-circuit overcurrent device.*

(FPN): See Section 300-13(b) for continuity of grounded conductor on multiwire circuits.

### 210-5. Color Code for Branch Circuits.

(a) **Grounded Conductor.** The grounded conductor of a branch circuit shall be identified by a continuous white or natural gray color. Where conductors of different systems are installed in the same raceway, box, auxiliary gutter, or other types of enclosures, one system grounded conductor, if required, shall have an outer covering of white or natural gray. Each other system grounded conductor, if required, shall have an outer covering of white with an identifiable colored stripe (not green) running along the insulation or other and different means of identification.

*Exception No. 1: The grounded conductors of mineral-insulated, metal-sheathed cable shall be identified by distinctive marking at the terminals during the process of installation.*

*Exception No. 2: As permitted in Exception No. 4 of Section 200-6(a) and the Exception to Section 200-6(b).*

(b) **Equipment Grounding Conductor.** The equipment grounding conductor of a branch circuit shall be identified by a continuous green color or a continuous green color with one or more yellow stripes unless it is bare.

*Exception No. 1: As permitted in Section 250-57(b), Exceptions No. 1 and 3 and Section 310-12(b), Exceptions No. 1 and 2.*

*Exception No. 2: The use of conductor insulation having a continuous green color or a continuous green color with one or more yellow stripes shall be permitted for internal wiring of equipment if such wiring does not serve as the lead wires for connection to branch-circuit conductors.*

### 210-6. Branch Circuit Voltage Limitations.

(a) **Occupancy Limitation.** In dwelling units and guest rooms of hotels, motels, and similar occupancies, the voltage shall not exceed 120 volts, nominal, between conductors that supply the terminals of:

(1) Lighting fixtures;

(2) Cord- and plug-connected loads of less than 1380 volt-amperes, nominal.

(b) **120 Volts Between Conductors.** Circuits not exceeding 120 volts, nominal, between conductors shall be permitted to supply:

(1) The terminals of medium-base screw-shell lampholders or lampholders of other types applied within their voltage ratings.

(2) Auxiliary equipment of electric discharge lamps.

(3) Cord- and plug-connected or permanently connected utilization equipment.

(c) **277 Volts to Ground.** Circuits exceeding 120 volts, nominal, between conductors and not exceeding 277 volts, nominal, to ground shall be permitted to supply:

(1) Lighting fixtures equipped with mogul-base screw-shell lampholders or with lampholders other than the screw-shell type applied within their voltage ratings.

(2) Auxiliary equipment of electric discharge lamps.

(3) Cord- and plug-connected or permanently connected utilization equipment.

(d) **600 Volts Between Conductors.** Circuits exceeding 277 volts, nominal, to ground and not exceeding 600 volts, nominal, between conductors shall be permitted to supply:

(1) The auxiliary equipment of electric discharge lamps mounted in permanently installed fixtures where the fixtures are mounted in accordance with one of the following:

a. Not less than a height of 22 feet (6.71 m) on poles or similar structures for the illumination of outdoor areas, such as highways, roads, bridges, athletic fields, or parking lots.

b. Not less than a height of 18 feet (5.49 m) on other structures, such as tunnels.

(2) Cord- and plug-connected or permanently connected utilization equipment.

(FPN): See Section 410-78 for auxiliary equipment limitations.

*Exception No. 1 to (b), (c) and (d) above: For lampholders of infrared industrial heating appliances as provided in Section 422-15(c).*

*Exception No. 2 to (b), (c) and (d) above: For railway properties as described in Section 110-19.*

#### 210-7. Receptacles and Cord Connectors.

(a) **Grounding Type.** Receptacles installed on 15- and 20-ampere branch circuits shall be of the grounding type. Grounding-type receptacles shall be installed only on circuits of the voltage class and current for which they are rated, except as provided in Tables 210-21(b)(2) and (b)(3).

*Exception: Nongrounding-type receptacles installed in accordance with Section 210-7(d), Exception.*

(b) **To Be Grounded.** Receptacles and cord connectors having grounding contacts shall have those contacts effectively grounded.

*Exception No. 1: Receptacles mounted on portable and vehicle-mounted generators in accordance with Section 250-6.*

*Exception No. 2: Ground-fault circuit-interrupter replacement receptacles as permitted by Section 210-7(d), Exception.*

(c) **Methods of Grounding.** The grounding contacts of receptacles and cord connectors shall be grounded by connection to the equipment grounding conductor of the circuit supplying the receptacle or cord connector.

(FPN): For installation requirements for the reduction of electrical noise, see Section 250-74, Exception No. 4.

The branch circuit or branch-circuit raceway shall include or provide a grounding conductor to which the grounding contacts of the receptacle or cord connector shall be connected.

(FPN): Section 250-91(b) describes acceptable grounding means.

(FPN): For extensions of existing branch circuits, see Section 250-50.

(d) **Replacements.** Grounding-type receptacles shall be used as replacements for existing nongrounding types and shall be connected to a grounding conductor installed in accordance with (c) above.

*Exception: Where a grounding means does not exist in the receptacle enclosure either a nongrounding or a ground-fault circuit-interrupter type of receptacle shall be used. A grounding conductor shall not be connected from*

*the ground-fault circuit-interrupter-type receptacle to any outlet supplied from the ground-fault circuit-interrupter-type receptacle.*

**(e) Cord- and Plug-Connected Equipment.** The installation of grounding-type receptacles shall not be used as a requirement that all cordand plug-connected equipment be of the grounded type.

(FPN): See Section 250-45 for type of cord- and plug-connected equipment to be grounded.

**(f) Noninterchangeable Types.** Receptacles connected to circuits having different voltages, frequencies, or types of current (ac or dc) on the same premises shall be of such design that the attachment plugs used on these circuits are not interchangeable.

## **210-8. Ground-Fault Circuit-Interrupter Protection for Personnel.**

### **(a) Dwelling Units.**

**(1)** All 125-volt, single-phase, 15- and 20-ampere receptacles installed in bathrooms shall have ground-fault circuit-interrupter protection for personnel.

**(2)** All 125-volt, single-phase, 15- or 20-ampere receptacles installed in garages shall have ground-fault circuit-interrupter protection for personnel.

*Exception No. 1 to (a)(2): Receptacles which are not readily accessible.*

*Exception No. 2 to (a)(2): Receptacles for appliances occupying dedicated space which are cord- and plug-connected in accordance with Section 400-7 (a)(6), (a)(7), or (a)(8).*

Receptacles installed under Exceptions to Section 210-8(a)(2) shall not be considered as meeting the requirements of Section 210-52(f).

**(3)** All 125-volt, single-phase, 15- and 20-ampere receptacles installed outdoors where there is direct grade level access to the dwelling unit and to the receptacles shall have ground-fault circuit-interrupter protection for personnel.

(FPN): See Section 215-9 for feeder protection.

For the purposes of this section, "direct grade level access" is defined as being located not more than 6 feet, 6 inches (1.98 m) above grade level and being readily accessible without entering or passing through a dwelling unit.

**(4)** At least one 125-volt, single-phase, 15- or 20-ampere receptacle installed in a basement shall have ground-fault circuit-interrupter protection for personnel and it shall be so identified.

**(5)** All 125-volt, single-phase, 15- and 20-ampere receptacles required by Section 210-52(b) installed within 6 feet (1.83 m) of the kitchen sink above counter top surfaces shall have ground-fault circuit-interrupter protection for personnel.

(FPN): The intent of this section is to permit the exemption of receptacles which are located specifically for appliances such as refrigerators and freezers from ground-fault circuit-interrupter protection for personnel.

**(6)** All 125-volt, single-phase, 15- or 20-ampere receptacles installed in bathhouses shall have ground-fault circuit-interrupter protection for personnel.

**(b) Hotels and Motels.** All 125-volt, single-phase, 15- and 20-ampere receptacles installed in bathrooms of guest rooms in hotels and motels shall have ground-fault circuit-interrupter protection for personnel.

**Bathroom:** As used in Section 210-8, a bathroom is an area including a basin with one or more of the following: a toilet, a tub, or a shower.

**210-9. Circuits Derived from Autotransformers.** Branch-circuits shall not be supplied by autotransformers.

*Exception No. 1: Where the system supplied has a grounded conductor that is electrically connected to a grounded conductor of the system supplying the autotransformer.*

*Exception No. 2: An autotransformer used to extend or add an individual branch circuit in an existing installation for an equipment load without the connection to a similar grounded conductor when transforming from a nominal 208 volts to a nominal 240-volt supply or similarly from 240 volts to 208 volts.*

(FPN): An autotransformer is a transformer in which a part of the winding is common to both primary and secondary circuits.

**210-10. Ungrounded Conductors Tapped from Grounded Systems.** Two-wire dc circuits and ac circuits of two or more ungrounded conductors shall be permitted to be tapped from the ungrounded conductors of circuits having a grounded neutral conductor. Switching devices in each tapped circuit shall have a pole in each ungrounded conductor. All poles of multipole switching devices shall manually switch together where such switching devices also serve as a disconnecting means as required by Section 422-21(b) for an appliance; Section 424-20 for a fixed electric space heating unit; Section 426-51 for electric de-icing and snow-melting equipment; Section 430-85 for a motor controller; and Section 430-103 for a motor.

## B. Branch-Circuit Ratings

**210-19. Conductors — Minimum Ampacity and Size.**

(a) **General.** Branch-circuit conductors shall have an ampacity not less than the maximum load to be served. In addition, conductors of multioutlet branch circuits supplying receptacles for cord- and plug-connected portable loads shall have an ampacity of not less than the rating of the branch circuit. Cable assemblies with the neutral conductor smaller than the ungrounded conductors shall be so marked.

(FPN): See Tables 310-16 through 310-31 for ampacity ratings of conductors.

(FPN): See Part B of Article 430 for minimum rating of motor branch-circuit conductors.

(FPN): See Section 310-10 for temperature limitation of conductors.

(FPN): Conductors for branch circuits as defined in Article 100, sized to prevent a voltage drop exceeding 3 percent at the farthest outlet of power, heating, and lighting loads, or combinations of such loads and where the maximum total voltage drop on both feeders and branch circuits to the farthest outlet does not exceed 5 percent, will provide reasonable efficiency of operation. See Section 215-2 for voltage drop on feeder conductors.

(b) **Household Ranges and Cooking Appliances.** Branch-circuit conductors supplying household ranges, wall-mounted ovens, counter-mounted cooking units, and other household cooking appliances shall have an ampacity not less than the rating of the branch circuit and not less than the maximum load to be served. For ranges of  $8\frac{3}{4}$  kW or more rating, the minimum branch-circuit rating shall be 40 amperes.

*Exception No. 1: The neutral conductor of a 3-wire branch circuit supplying a household electric range, a wall-mounted oven, or a counter-mounted cooking unit shall be permitted to be smaller than the ungrounded conductors where the maximum demand of a range of 8¾ kW or more rating has been computed according to Column A of Table 220-19, but shall have an ampacity of not less than 70 percent of the branch-circuit rating and shall not be smaller than No. 10.*

*Exception No. 2: Tap conductors supplying electric ranges, wall-mounted electric ovens, and counter-mounted electric cooking units from a 50-ampere branch circuit shall have an ampacity of not less than 20 and shall be sufficient for the load to be served. The taps shall not be longer than necessary for servicing the appliance.*

**(c) Other Loads.** Branch-circuit conductors supplying loads other than cooking appliances as covered in (b) above and as listed in Section 210-2 shall have an ampacity sufficient for the loads served and shall not be smaller than No. 14.

*Exception No. 1: Tap conductors for such loads shall have an ampacity not less than 15 for circuits rated less than 40 amperes and not less than 20 for circuits rated at 40 or 50 amperes and only where these tap conductors supply any of the following loads:*

*a. Individual lampholders or fixtures with taps extending not longer than 18 inches (457 mm) beyond any portion of the lampholder or fixture.*

*b. A fixture having tap conductors as provided in Section 410-67.*

*c. Individual outlets with taps not over 18 inches (457 mm) long.*

*d. Infrared lamp industrial heating appliances.*

*e. Nonheating leads of de-icing and snow-melting cables and mats.*

*Exception No. 2: Fixture wires and cords as permitted in Section 240-4.*

**210-20. Overcurrent Protection.** Branch-circuit conductors and equipment shall be protected by overcurrent protective devices having a rating or setting (1) not exceeding that specified in Section 240-3 for conductors; (2) not exceeding that specified in the applicable articles referenced in Section 240-2 for equipment; and (3) as provided for outlet devices in Section 210-21.

*Exception No. 1: Tap conductors as permitted in Section 210-19(c) shall be permitted to be protected by the branch-circuit overcurrent device.*

*Exception No. 2: Fixture wires and cords as permitted in Section 240-4.*

(FPN): See Section 240-1 for the purpose of overcurrent protection and Sections 210-22 and 220-3 for continuous loads.

**210-21. Outlet Devices.** Outlet devices shall have an ampere rating not less than the load to be served and shall comply with (a) and (b) below.

**(a) Lampholders.** Where connected to a branch circuit having a rating in excess of 20 amperes, lampholders shall be of the heavy-duty type: A heavy-duty lampholder shall have a rating of not less than 660 watts if of the medium type and not less than 750 watts if of any other type.

**(b) Receptacles.**

(1) A single receptacle installed on an individual branch circuit shall have an ampere rating of not less than that of the branch circuit.

(FPN): See definition of Receptacle in Article 100.

(2) Where connected to a branch circuit supplying two or more receptacles or outlets, a receptacle shall not supply a total cord- and plug-connected load in excess of the maximum specified in Table 210-21(b)(2).

(3) Where connected to a branch circuit supplying two or more receptacles or outlets, receptacle ratings shall conform to the values listed in Table 210-21(b)(3) or where larger than 50 amperes, the receptacle rating shall not be less than the branch-circuit rating.

(4) It shall be acceptable to base the ampere rating of a range receptacle on a single range demand load specified in Table 220-19.

Table 210-21(b)(2)  
Maximum Cord- and Plug-Connected Load to Receptacle

Circuit Rating Amperes	Receptacle Rating Amperes	Maximum Load Amperes
15 or 20	15	12
20	20	16
30	30	24

Table 210-21(b)(3)  
Receptacle Ratings for Various Size Circuits

Circuit Rating Amperes	Receptacle Rating Amperes
15	Not over 15
20	15 or 20
30	30
40	40 or 50
50	50

**210-22. Maximum Loads.** The total load shall not exceed the rating of the branch circuit, and it shall not exceed the maximum loads specified in (a) through (c) below under the conditions specified therein.

(a) **Motor-Operated and Combination Loads.** Where a circuit supplies only motor-operated loads, Article 430 shall apply. Where a circuit supplies only air-conditioning and/or refrigerating equipment, Article 440 shall apply. For circuits supplying loads consisting of motor-operated utilization equipment that is fastened in place and that has a motor larger than  $\frac{1}{8}$  horsepower in combination with other loads, the total computed load shall be based on 125 percent of the largest motor load plus the sum of the other loads.

(b) **Inductive Lighting Loads.** For circuits supplying lighting units having ballasts, transformers, or autotransformers, the computed load shall be based on the total ampere ratings of such units and not on the total watts of the lamps.

(c) **Other Loads.** Continuous loads, such as store lighting and similar loads, shall not exceed 80 percent of the rating of the branch circuit.

*Exception No. 1: Motor loads having demand factors computed in accordance with Article 430.*



*Exception No. 2: Circuits supplied by an assembly together with its overcurrent devices that is listed for continuous operation at 100 percent of its rating.*

It shall be acceptable to apply demand factors for range loads in accordance with Table 220-19, including Note 4.

**210-23. Permissible Loads.** In no case shall the load exceed the branch-circuit ampere rating. It shall be acceptable for an individual branch circuit to supply any load for which it is rated. A branch circuit supplying two or more outlets shall supply only the loads specified according to its size in (a) through (c) below and summarized in Section 210-24 and Table 210-24.

(a) **15- and 20-Ampere Branch Circuits.** A 15- or 20-ampere branch circuit shall be permitted to supply lighting units, other utilization equipment, or a combination of both. The rating of any one cord- and plug-connected utilization equipment shall not exceed 80 percent of the branch-circuit ampere rating. The total rating of utilization equipment fastened in place shall not exceed 50 percent of the branch-circuit ampere rating where lighting units, cord- and plug-connected utilization equipment not fastened in place, or both, are also supplied.

*Exception: The small appliance branch circuits required in a dwelling unit(s) by Section 220-4(b) shall supply only the receptacle outlets specified in that section.*

(b) **30-Ampere Branch Circuits.** A 30-ampere branch circuit shall be permitted to supply fixed lighting units with heavy-duty lampholders in other than dwelling unit(s) or utilization equipment in any occupancy. A rating of any one cord- and plug-connected utilization equipment shall not exceed 80 percent of the branch-circuit ampere rating.

(c) **40- and 50-Ampere Branch Circuits.** A 40- or 50-ampere branch circuit shall be permitted to supply cooking appliances that are fastened in place in any occupancy. In other than dwelling units, such circuits shall be permitted to supply fixed lighting units with heavy-duty lampholders, infrared heating units or other utilization equipment.

(d) **Branch Circuits Larger than 50 Amperes.** Branch circuits larger than 50 amperes shall supply only nonlighting outlet loads.

**210-24. Branch-Circuit Requirements — Summary.** The requirements for circuits having two or more outlets, other than the receptacle circuits of Section 220-4(b) as specifically provided for above, are summarized in Table 210-24. Branch circuits in dwelling units shall not be connected to serve more than one dwelling unit.

*Exception: Branch circuits in two-family or multifamily dwellings, with dwelling units under single management, shall be permitted to be connected to serve more than one dwelling unit for the purpose of central alarm, signal, communications, or similar functions.*

### C. Required Outlets

**210-50. General.** Receptacle outlets shall be installed as specified in Sections 210-52 through 210-63.

(a) **Cord Pendants.** A cord connector that is supported by a permanently installed cord pendant shall be considered a receptacle outlet.

**Table 210-24**  
**Summary of Branch-Circuit Requirements**

(Type FEP, FEPB, SA, TW, RH, RHW, RHH, THHN, THW, THWN, and XHHW conductors in raceway or cable.)

CIRCUIT RATING	15 Amp	20 Amp	30 Amp	40 Amp	50 Amp
<b>CONDUCTORS</b>					
(Min. Size)					
Circuit Wires*	14	12	10	8	6
Taps	14	14	14	12	12
Fixture Wires and Cords	Refer to Section 240-4				
<b>OVERCURRENT PROTECTION</b>					
	15 Amp	20 Amp	30 Amp	40 Amp	50 Amp
<b>OUTLET DEVICES:</b>					
Lampholders Permitted	Any Type	Any Type	Heavy Duty	Heavy Duty	Heavy Duty
Receptacle Rating**	15 Max. Amp	15 or 20 Amp	30 Amp	40 or 50 Amp	50 Amp
<b>MAXIMUM LOAD</b>					
	15 Amp	20 Amp	30 Amp	40 Amp	50 Amp
<b>PERMISSIBLE LOAD</b>					
	Refer to Section 210-23(a)	Refer to Section 210-23(a)	Refer to Section 210-23(b)	Refer to Section 210-23(c)	Refer to Section 210-23(c)

\* These gages are for copper conductors.

\*\* For receptacle rating of cord-connected electric-discharge lighting fixtures, see Section 410-30(c).

**(b) Cord Connections.** A receptacle outlet shall be installed wherever flexible cords with attachment plugs are used. Where flexible cords are permitted to be permanently connected, it shall be permitted to omit receptacles for such cords.

**(c) Laundry Outlet.** Appliance outlets installed in a dwelling unit for specific appliances, such as laundry equipment, shall be installed within 6 feet (1.83 m) of the intended location of the appliance.

### 210-52. Dwelling Unit Receptacle Outlets.

**(a) General Provisions.** In every kitchen, family room, dining room, living room, parlor, library, den, sun room, bedroom, recreation room, or similar rooms of dwelling units, receptacle outlets shall be installed so that no point along the floor line in any wall space is more than 6 feet (1.83 m), measured horizontally, from an outlet in that space, including any wall space 2 feet (610 mm) or more in width and the wall space occupied by sliding panels in exterior walls. The wall space afforded by fixed room dividers, such as free-standing bar-type counters, shall be included in the 6-foot (1.83-m) measurement.

As used in this section a "wall space" shall be considered a wall unbroken along the floor line by doorways, fireplaces, and similar openings. Each wall space 2 or more feet (610 mm or more) wide shall be treated individually and

separately from other wall spaces within the room. A wall space shall be permitted to include two or more walls of a room (around corners) where unbroken at the floor line.

(FPN): The purpose of this requirement is to minimize the use of cords across doorways, fireplaces, and similar openings.

Receptacle outlets shall, insofar as practicable, be spaced equal distances apart. Receptacle outlets in floors shall not be counted as part of the required number of receptacle outlets unless located close to the wall.

The receptacle outlets required by this section shall be in addition to any receptacle that is part of any lighting fixture or appliance, located within cabinets or cupboards, or located over 5½ feet (1.68 m) above the floor.

*Exception: Permanently installed electric baseboard heaters equipped with factory-installed receptacle outlets or outlets provided as a separate assembly by the manufacturer shall be permitted as the required outlet or outlets for the wall space utilized by such permanently installed heaters. Such receptacle outlets shall not be connected to the heater circuits.*

(FPN): Listed baseboard heaters include instructions which may not permit their installation below dwelling unit receptacle outlets.

**(b) Counter Tops.** In kitchen and dining areas of dwelling units a receptacle outlet shall be installed at each counter space wider than 12 inches (305 mm). Counter top spaces separated by range tops, refrigerators, or sinks shall be considered as separate counter top spaces. Receptacles rendered inaccessible by appliances fastened in place or appliances occupying dedicated space shall not be considered as these required outlets.

**(c) Bathrooms.** In dwelling units at least one wall receptacle outlet shall be installed in the bathroom adjacent to the basin location. See Section 210-8(a)(1).

**(d) Outdoor Outlets.** For a one-family dwelling at least one receptacle outlet accessible at grade level shall be installed outdoors. For a two-family dwelling at least one receptacle outlet accessible at grade level shall be installed outdoors for each dwelling unit which is at grade level. See Section 210-8(a)(3).

**(e) Laundry Areas.** In dwelling units at least one receptacle outlet shall be installed for the laundry.

*Exception No. 1: In a dwelling unit that is an apartment or living area in a multifamily building where laundry facilities are provided on the premises that are available to all building occupants, a laundry receptacle shall not be required.*

*Exception No. 2: In other than one-family dwellings where laundry facilities are not to be installed or permitted, a laundry receptacle shall not be required.*

**(f) Basements and Garages.** For a one-family dwelling, at least one receptacle outlet, in addition to any provided for laundry equipment, shall be installed in each basement and in each attached garage, and in each detached garage with electric power. See Sections 210-8(a)(2) and (a)(4).

**210-60. Guest Rooms.** Guest rooms in hotels, motels, and similar occupancies shall have receptacle outlets installed in accordance with Section 210-52. See Section 210-8(b).

*Exception: In rooms of hotels and motels, the required number of receptacle outlets determined by Section 210-52(a) shall be permitted to be located convenient for permanent furniture layout.*

**210-62. Show Windows.** At least one receptacle outlet shall be installed directly above a show window for each 12 linear feet (3.66 m) or major fraction thereof of show window area measured horizontally at its maximum width.

**210-63. Rooftop Heating, Air-Conditioning, and Refrigeration Equipment Outlet.** A 125-volt, single-phase, 15- or 20-ampere rated receptacle outlet shall be installed at an accessible location for the servicing of rooftop-mounted heating, air-conditioning, and refrigeration equipment. The receptacle outlet shall be located on the same roof level and within 75 feet (22.82 m) of the heating, air-conditioning, and refrigeration equipment. The receptacle outlet shall not be connected to the load side of the equipment disconnecting means.

*Exception: One- and two-family dwellings.*

**210-70. Lighting Outlets Required.** Lighting outlets shall be installed where specified in (a) and (b) below.

**(a) Dwelling Unit(s).** At least one wall switch-controlled lighting outlet shall be installed in every habitable room; in bathrooms, hallways, stairways, attached garages, and detached garages with electric power; and at outdoor entrances or exits.

(FPN): A vehicle door in an attached garage is not considered as an outdoor entrance.

At least one lighting outlet shall be installed in an attic, underfloor space, utility room and basement only where these spaces are used for storage or contain equipment requiring servicing.

*Exception No. 1: In habitable rooms, other than kitchens and bathrooms, one or more receptacles controlled by a wall switch shall be permitted in lieu of lighting outlets.*

*Exception No. 2: In hallways, stairways, and at outdoor entrances remote, central, or automatic control of lighting shall be permitted.*

**(b) Guest Rooms.** At least one wall switch-controlled lighting outlet or wall switch-controlled receptacle shall be installed in guest rooms in hotels, motels, or similar occupancies.

## ARTICLE 215 — FEEDERS

**215-1. Scope.** This article covers the installation requirements and minimum size and ampacity of conductors for feeders supplying branch-circuit loads as computed in accordance with Article 220.

*Exception: Feeders for electrolytic cells as covered in Section 668-3(c), Exceptions No. 1 and 4.*

**215-2. Minimum Rating and Size.** Feeder conductors shall have an ampacity not lower than required to supply the load as computed in Parts B, C, and D of Article 220. The minimum sizes shall be as specified in (a) and (b) below

under the conditions stipulated. Feeder conductors for a dwelling unit or a mobile home need not be larger than service-entrance conductors. Note 3 of Table 310-16 shall be permitted to be used for conductor size.

(a) **For Specified Circuits.** The ampacity of feeder conductors shall not be less than 30 where the load supplied consists of the following number and types of circuits: (1) two or more 2-wire branch circuits supplied by a 2-wire feeder; (2) more than two 2-wire branch circuits supplied by a 3-wire feeder; and (3) two or more 3-wire branch circuits supplied by a 3-wire feeder.

(b) **Ampacity Relative to Service-Entrance Conductors.** The feeder conductor ampacity shall not be lower than that of the service-entrance conductors where the feeder conductors carry the total load supplied by service-entrance conductors with an ampacity of 55 or less.

(FPN): See Examples 1 through 8 in Chapter 9.

(FPN): Conductors for feeders as defined in Article 100, sized to prevent a voltage drop exceeding 3 percent at the farthest outlet of power, heating, and lighting loads, or combinations of such loads and where the maximum total voltage drop on both feeders and branch circuits to the farthest outlet does not exceed 5 percent, will provide reasonable efficiency of operation.

(FPN): See Section 210-19(a) for voltage drop for branch circuits.

**215-3. Overcurrent Protection.** Feeders shall be protected against overcurrent in accordance with the provisions of Part A of Article 240.

**215-4. Feeders with Common Neutral.**

(a) **Feeders with Common Neutral.** Feeders containing a common neutral shall be permitted to supply two or three sets of 3-wire feeders, or two sets of 4-wire or 5-wire feeders.

(b) **In Metal Raceway or Enclosure.** Where installed in a metal raceway or other metal enclosure, all conductors of all feeders using a common neutral shall be enclosed within the same raceway or other enclosure as required in Section 300-20.

**215-5. Diagrams of Feeders.** If required by the authority having jurisdiction, a diagram showing feeder details shall be provided prior to the installation of the feeders. Such a diagram shall show the area in square feet of the building or other structure supplied by each feeder, the total connected load before applying demand factors, the demand factors used, the computed load after applying demand factors, and the size and type of conductors to be used.

**215-6. Feeder Conductor Grounding Means.** Where a feeder supplies branch circuits in which equipment grounding conductors are required, the feeder shall include or provide a grounding means in accordance with the provisions of Section 250-57 to which the equipment grounding conductors of the branch circuits shall be connected.

**215-7. Ungrounded Conductors Tapped from Grounded Systems.** Two-wire dc circuits and ac circuits of two or more ungrounded conductors shall be permitted to be tapped from the ungrounded conductors of circuits having a grounded neutral conductor. Switching devices in each tapped circuit shall have a pole in each ungrounded conductor.

**215-8. Means of Identifying Conductor with the Higher Voltage to Ground.** On a 4-wire, delta-connected secondary where the midpoint of one phase is grounded to supply lighting and similar loads, the phase conductor having the higher voltage to ground shall be identified by an outer finish that is orange in color or by tagging or other effective means. Such identification shall be placed at each point where a connection is made if the neutral conductor is also present.

**215-9. Ground-Fault Protection for Personnel.** Feeders supplying 15- and 20-ampere receptacle branch circuits shall be permitted to be protected by a ground-fault circuit-interrupter in lieu of the provisions for such interrupters as specified in Section 210-8 and Article 305.

## ARTICLE 220 — BRANCH-CIRCUIT AND FEEDER CALCULATIONS

### A. General

**220-1. Scope.** This article provides requirements for determining the number of branch circuits required and for computing branch-circuit and feeder loads.

*Exception: Branch-circuit and feeder calculations for electrolytic cells as covered in Section 668-3(c), Exceptions No. 1 and 4.*

**220-2. Voltages.** Unless other voltages are specified, for purposes of computing branch-circuit and feeder loads, nominal system voltages of 120, 120/240, 208Y/120, 240, 480Y/277, 480, and 600 volts shall be used.

**220-3. Computation of Branch Circuits.** Branch-circuit loads shall be computed as shown in (a) through (d) below.

(FPN): See Section 600-6(c) for exterior signs and outline lighting.

**(a) Continuous and Noncontinuous Loads.** The branch-circuit rating shall not be less than the noncontinuous load plus 125 percent of the continuous load.

*Exception: Where the assembly, including overcurrent devices, is listed for continuous operation of 100 percent of its rating.*

**(b) Lighting Load for Listed Occupancies.** A unit load of not less than that specified in Table 220-3(b) for occupancies listed therein shall constitute the minimum lighting load for each square foot (0.093 sq m) of floor area. The floor area for each floor shall be computed from the outside dimensions of the building, apartment, or other area involved. For dwelling unit(s), the computed floor area shall not include open porches, garages, or unused or unfinished spaces not adaptable for future use.

(FPN): The unit values herein are based on minimum load conditions and 100 percent power factor, and may not provide sufficient capacity for the installation contemplated.

**(c) Other Loads — All Occupancies.** In all occupancies the minimum load for each outlet for general-use receptacles and outlets not used for general

Table 220-3(b). General Lighting Loads by Occupancies

Type of Occupancy	Unit Load per Sq. Ft. (Volt-Amperes)
Armories and Auditoriums	1
Banks	3½**
Barber Shops and Beauty Parlors	3
Churches	1
Clubs	2
Court Rooms	2
*Dwelling Units	3
Garages — Commercial (storage)	½
Hospitals	2
*Hotels and Motels, including apartment houses without provisions for cooking by tenants	2
Industrial Commercial (Loft) Buildings	2
Lodge Rooms	1½
Office Buildings	3½**
Restaurants	2
Schools	3
Stores	3
Warehouses (storage)	¼
In any of the above occupancies except one-family dwellings and individual dwelling units of two-family and multifamily dwellings:	
Assembly Halls and Auditoriums	1
Halls, Corridors, Closets, Stairways	½
Storage Spaces	¼

For SI units: one square foot = 0.093 square meter.

\* All general use receptacle outlets of 20-ampere or less rating in one-family, two-family and multifamily dwellings and in guest rooms of hotels and motels [except those connected to the receptacle circuits specified in Sections 220-4(b) and (c)] shall be considered as outlets for general illumination, and no additional load calculations shall be required for such outlets.

\*\* In addition a unit load of 1 volt-ampere per square foot shall be included for general purpose receptacle outlets when the actual number of general purpose receptacle outlets is unknown.

illumination shall be not less than the following, the loads shown being based on nominal branch-circuit voltages.

- (1) Outlet for a specific appliance or other load except for a motor load ..... ampere rating of appliance or load served.
- (2) Outlet for motor load ..... See Sections 430-22 and 430-24 and Article 440.
- (3) An outlet supplying recessed lighting fixture(s) shall be the maximum volt-ampere rating of the equipment and lamps for which the fixture(s) is rated.
- (4) Outlet for heavy-duty lampholder ..... 600 volt-amperes.
- (5) \*Other outlets ..... 180 volt-amperes per outlet.

For receptacle outlets, each single or multiple receptacle shall be considered at not less than 180 volt-amperes.

\* This provision shall not be applicable to receptacle outlets connected to the circuit specified in Section 220-4(b).

*Exception No. 1: Where fixed multioutlet assemblies are employed, each 5 feet (1.52 m) or fraction thereof of each separate and continuous length shall be considered as one outlet of not less than 180 volt-amperes capacity, except in locations where a number of appliances are likely to be used simultaneously, when each 1 foot (305 mm) or fraction thereof shall be considered as an outlet of not less than 180 volt-amperes. The requirements of this exception shall not apply to dwelling unit(s) or the guest rooms of hotels or motels.*

*Exception No. 2: Table 220-19 shall be considered as an acceptable method of computing the load for a household electric range.*

*Exception No. 3: A load of not less than 200 volt-amperes per linear foot (305 mm) of show window, measured horizontally along its base, shall be permitted instead of the specified unit load per outlet.*

*Exception No. 4: The loads of outlets serving switchboards and switching frames in telephone exchanges shall be waived from the computations.*

*Exception No. 5: Section 220-18 shall be considered as an acceptable method of computing the load for a household electric clothes dryer.*

**(d) Loads for Additions to Existing Installations.**

**(1) Dwelling Units.** Loads for structural additions to an existing dwelling unit or to a previously unwired portion of an existing dwelling unit, either of which exceeds 500 square feet (46.5 sq m), shall be computed in accordance with (b) above. Loads for new circuits or extended circuits in previously wired dwelling units shall be computed in accordance with either (b) or (c) above.

**(2) Other than Dwelling Units.** Loads for new circuits or extended circuits in other than dwelling units shall be computed in accordance with either (b) or (c) above.

**220-4. Branch Circuits Required.** Branch circuits for lighting and for appliances, including motor-operated appliances, shall be provided to supply the loads computed in accordance with Section 220-3. In addition, branch circuits shall be provided for specific loads not covered by Section 220-3 where required elsewhere in this Code; for small appliance loads as specified in (b) below; and for laundry loads as specified in (c) below.



**(a) Number of Branch Circuits.** The minimum number of branch circuits shall be determined from the total computed load and the size or rating of the circuits used. In all installations the number of circuits shall be sufficient to supply the load served. In no case shall the load on any circuit exceed the maximum specified by Section 210-22.

**(b) Small Appliance Branch Circuits — Dwelling Unit.**

(1) In addition to the number of branch circuits determined in accordance with (a) above, two or more 20-ampere small-appliance branch circuits shall be provided for all receptacle outlets specified by Section 210-52 for the small-appliance loads, including refrigeration equipment, in the kitchen, pantry, breakfast room, and dining room of a dwelling unit. Such circuits, whether two or more are used, shall have no other outlets.

*Exception No. 1: A receptacle installed solely for the electric supply to and support of an electric clock in any of the rooms specified above.*

*Exception No. 2: Outdoor receptacles.*

*Exception No. 3: In addition to the required receptacles specified by Section 210-52, switched receptacles supplied from a general-purpose branch circuit as defined in Section 210-70(a); Exception No. 1 shall be permitted.*

(2) Countertop receptacle outlets installed in the kitchen shall be supplied by not less than two small-appliance branch circuits, either or both of which shall also be permitted to supply receptacle outlets in kitchen and other rooms specified in (b)(1) above. Additional small-appliance branch circuits shall be permitted to supply receptacle outlets in kitchen and other rooms specified in (b)(1) above.

**(c) Laundry Branch Circuits — Dwelling Unit.** In addition to the number of branch circuits determined in accordance with (a) and (b) above, at least one additional 20-ampere branch circuit shall be provided to supply the laundry receptacle outlet(s) required by Section 210-52(e). This circuit shall have no other outlets.

**(d) Load Evenly Proportioned Among Branch Circuits.** Where the load is computed on a volt-amperes-per-square-foot (0.093 sq.m) basis, the wiring system up to and including the branch-circuit panelboard(s) shall be provided to serve not less than the calculated load. This load shall be evenly proportioned among multioutlet branch circuits within the panelboard(s). Branch-circuit overcurrent devices and circuits need only be installed to serve the connected load.

(FPN): See Examples 1(a), 1(b), 2(b) and 4(a), Chapter 9.

## B. Feeders

### 220-10. General.

**(a) Ampacity and Computed Loads.** Feeder conductors shall have sufficient ampacity to supply the load served. In no case shall the computed load of a feeder be less than the sum of the loads on the branch circuits supplied as determined by Part A of this article after any applicable demand factors permitted by Parts B, C, or D have been applied.

(FPN): See Examples 1 through 8, Chapter 9. See Section 210-22(b) for maximum load in amperes permitted for lighting units operating at less than 100 percent power factor.

**(b) Continuous and Noncontinuous Loads.** Where a feeder supplies continuous loads or any combination of continuous and noncontinuous loads, the rating of the overcurrent device shall not be less than the noncontinuous load plus 125 percent of the continuous load.

The ampacity of the ungrounded service conductor shall not be less than the noncontinuous load plus 125 percent of the continuous load.

*Exception: Where the assembly including the overcurrent devices protecting the feeder(s) are listed for operation at 100 percent of their rating, neither the ampere rating of the overcurrent device nor the ampacity of the feeder conductors shall be less than the sum of the continuous load plus the noncontinuous load.*

**220-11. General Lighting.** The demand factors listed in Table 220-11 shall apply to that portion of the total branch-circuit load computed for general illumination. They shall not be applied in determining the number of branch circuits for general illumination.

(FPN): See Section 220-16 for application of demand factors to small appliance and laundry loads in dwellings.

**Table 220-11. Lighting Load Feeder Demand Factors**

Type of Occupancy	Portion of Lighting Load to Which Demand Factor Applies (volt-amperes)	Demand Factor Percent
Dwelling Units	First 3000 or less at.....	100
	From 3001 to 120,000 at.....	35
	Remainder over 120,000 at.....	25
*Hospitals	First 50,000 or less at.....	40
	Remainder over 50,000 at.....	20
*Hotels and Motels — Including Apartment Houses without Provision for Cooking by Tenants	First 20,000 or less at.....	50
	From 20,001 to 100,000 at.....	40
	Remainder over 100,000 at.....	30
Warehouses (Storage)	First 12,500 or less at.....	100
	Remainder over 12,500 at.....	50
All Others	Total Volt-amperes.....	100

\* The demand factors of this table shall not apply to the computed load of feeders to areas in hospitals, hotels, and motels where the entire lighting is likely to be used at one time, as in operating rooms, ballrooms, or dining rooms.

**220-12. Show-Window Lighting.** For show-window lighting, a load of not less than 200 volt-amperes shall be included for each linear foot (305 mm) of show window, measured horizontally along its base.

(FPN): See Section 220-3(c), Exception No. 3, for branch circuits supplying show windows.

**220-13. Receptacle Loads — Nondwelling Units.** In other than dwelling units, the use of the demand factors for lighting loads in Table 220-11 or those shown in Table 220-13 shall be permitted for receptacle loads computed at not more than 180 volt-amperes per outlet in accordance with Section 220-3(c)(5).

**Table 220-13**  
**Demand Factors for Nondwelling Receptacle Loads:**

Portion of Receptacle Load to which demand factor applies (volt-amperes)	Demand Factor Percent
First 10 kVA or less	100
Remainder over 10 kVA at	50

**220-14. Motors.** Motor loads shall be computed in accordance with Sections 430-24, 430-25, and 430-26.

**220-15. Fixed Electric Space Heating.** Fixed electric space heating loads shall be computed at 100 percent of the total connected load; however in no case shall a feeder load current rating be less than the rating of the largest branch circuit supplied.

*Exception No. 1: Where reduced loading of the conductors results from units operating on duty-cycle, intermittently, or from all units not operating at one time, the authority having jurisdiction may grant permission for feeder conductors to have an ampacity less than 100 percent, provided the conductors have an ampacity for the load so determined.*

*Exception No. 2: The use of the optional calculations in Sections 220-30 and 220-31 shall be permitted for fixed electric space heating loads in a dwelling unit. In a multifamily dwelling the use of the optional calculation in Section 220-32 shall be permitted.*

**220-16. Small Appliance and Laundry Loads — Dwelling Unit.**

**(a) Small Appliance Circuit Load.** In each dwelling unit the feeder load shall be computed at 1500 volt-amperes for each 2-wire small appliance branch circuit required by Section 220-4(b) for small appliances supplied by 15- or 20-ampere receptacles on 20-ampere branch circuits in the kitchen, pantry, dining room, and breakfast room. Where the load is subdivided through two or more feeders, the computed load for each shall include not less than 1500 volt-amperes for each 2-wire branch circuit for small appliances. These loads shall be permitted to be included with the general lighting load and subjected to the demand factors permitted in Table 220-11 for the general lighting load.

**(b) Laundry Circuit Load.** A feeder load of not less than 1500 volt-amperes shall be included for each 2-wire laundry branch circuit installed as required by Section 220-4(c). It shall be permissible to include this load with

the general lighting load and subject it to the demand factors provided in Section 220-11.

**220-17. Appliance Load — Dwelling Unit(s).** It shall be permissible to apply a demand factor of 75 percent to the nameplate-rating load of four or more appliances fastened in place served by the same feeder in a one-family, two-family, or multifamily dwelling.

*Exception: This demand factor shall not be applied to electric ranges, clothes dryers, space heating equipment, or air-conditioning equipment.*

**220-18. Electric Clothes Dryers — Dwelling Unit(s).** The load for household electric clothes dryers in a dwelling unit(s) shall be 5000 watts (volt-amperes) or the nameplate rating, whichever is larger, for each dryer served. The use of the demand factors in Table 220-18 shall be permitted.

**Table 220-18**  
**Demand Factors for Household Electric Clothes Dryers**

Number of Dryers	Demand Factor Percent
1	100
2	100
3	100
4	100
5	80
6	70
7	65
8	60
9	55
10	50
11-13	45
14-19	40
20-24	35
25-29	32.5
30-34	30
35-39	27.5
40 & over	25

**220-19. Electric Ranges and Other Cooking Appliances — Dwelling Unit(s).** The feeder demand load for household electric ranges, wall-mounted ovens, counter-mounted cooking units, and other household cooking appliances individually rated in excess of  $1\frac{3}{4}$  kW shall be permitted to be computed in accordance with Table 220-19. Where two or more single-phase ranges are supplied by a 3-phase, 4-wire feeder, the total load shall be computed on the basis of twice the maximum number connected between any two phases. kVA shall be considered equivalent to kW for loads computed under this section.

(FPN): See Example 5(a), Chapter 9.

**Table 220-19. Demand Loads for Household Electric Ranges, Wall-Mounted Ovens, Counter-Mounted Cooking Units, and Other Household Cooking Appliances over 1¼ kW Rating. Column A to be used in all cases except as otherwise permitted in Note 3 below.**

NUMBER OF APPLIANCES	Maximum Demand (See Notes)	Demand Factors Percent (See Note 3)	
	COLUMN A (Not over 12 kW Rating)	COLUMN B (Less than 3½ kW Rating)	COLUMN C (3½ kW to 8¼ kW Rating)
1	8 kW	80%	80%
2	11 kW	75%	65%
3	14 kW	70%	55%
4	17 kW	66%	50%
5	20 kW	62%	45%
6	21 kW	59%	43%
7	22 kW	56%	40%
8	23 kW	53%	36%
9	24 kW	51%	35%
10	25 kW	49%	34%
11	26 kW	47%	32%
12	27 kW	45%	32%
13	28 kW	43%	32%
14	29 kW	41%	32%
15	30 kW	40%	32%
16	31 kW	39%	28%
17	32 kW	38%	28%
18	33 kW	37%	28%
19	34 kW	36%	28%
20	35 kW	35%	28%
21	36 kW	34%	26%
22	37 kW	33%	26%
23	38 kW	32%	26%
24	39 kW	31%	26%
25	40 kW	30%	26%
26-30	15 kW plus 1 kW	30%	24%
31-40	for each range	30%	22%
41-50	25 kW plus ¼	30%	20%
51-60	kW for each	30%	18%
61 & over	range	30%	16%

Note 1. Over 12 kW through 27 kW ranges all of same rating. For ranges individually rated more than 12 kW but not more than 27 kW, the maximum demand in Column A shall be increased 5 percent for each additional kW of rating or major fraction thereof by which the rating of individual ranges exceeds 12 kW.

Note 2. Over 12 kW through 27 kW ranges of unequal ratings. For ranges individually rated more than 12 kW and of different ratings but none exceeding 27 kW, an average value of rating shall be computed by adding together the ratings of all ranges to obtain the total connected load (using 12 kW for any range rated less than 12 kW) and dividing by the total number of ranges; and then the maximum demand in Column A shall be increased 5

percent for each kW or major fraction thereof by which this average value exceeds 12 kW.

Note 3. Over 1¼ kW through 8¾ kW. In lieu of the method provided in Column A, it shall be permissible to add the nameplate ratings of all ranges rated more than 1¼ kW but not more than 8¾ kW and multiply the sum by the demand factors specified in Column B or C for the given number of appliances.

Note 4. Branch-Circuit Load. It shall be permissible to compute the branch-circuit load for one range in accordance with Table 220-19. The branch-circuit load for one wall-mounted oven or one counter-mounted cooking unit shall be the nameplate rating of the appliance. The branch-circuit load for a counter-mounted cooking unit and not more than two wall-mounted ovens, all supplied from a single branch circuit and located in the same room, shall be computed by adding the nameplate rating of the individual appliances and treating this total as equivalent to one range.

Note 5. This table also applies to household cooking appliances rated over 1¼ kW and used in instructional programs.

(FPN): See Table 220-20 for commercial cooking equipment.

(FPN): See Examples, Chapter 9.

**220-20. Kitchen Equipment — Other than Dwelling Unit(s).** It shall be permissible to compute the load for commercial electric cooking equipment, dishwasher booster heaters, water heaters, and other kitchen equipment in accordance with Table 220-20. These demand factors shall be applied to all equipment which has either thermostatic control or intermittent use as kitchen equipment. They shall not apply to space heating, ventilating or air-conditioning equipment.

However, in no case shall the feeder demand be less than the sum of the largest two kitchen equipment loads.

**Table 220-20**  
**Feeder Demand Factors for Kitchen Equipment —**  
**Other than Dwelling Unit(s)**

Number of Units of Equipment	Demand Factors Percent
1	100
2	100
3	90
4	80
5	70
6 & over	65

**220-21. Noncoincident Loads.** Where it is unlikely that two dissimilar loads will be in use simultaneously, it shall be permissible to omit the smaller of the two in computing the total load of a feeder.

**220-22. Feeder Neutral Load.** The feeder neutral load shall be the maximum unbalance of the load determined by this article. The maximum unbalanced load shall be the maximum net computed load between the neutral and any one ungrounded conductor, except that the load thus

obtained shall be multiplied by 140 percent for 5-wire, 2-phase systems. For a feeder supplying household electric ranges, wall-mounted ovens, counter-mounted cooking units, and electric dryers the maximum unbalanced load shall be considered as 70 percent of the load on the ungrounded conductors, as determined in accordance with Table 220-19 for ranges and Table 220-18 for dryers. For 3-wire dc or single-phase ac, 4-wire, 3-phase, and 5-wire, 2-phase systems, a further demand factor of 70 percent shall be permitted for that portion of the unbalanced load in excess of 200 amperes. There shall be no reduction of the neutral capacity for that portion of the load which consists of electric-discharge lighting, data processing, or similar equipment, and supplied from a 4-wire, wye-connected 3-phase system.

(FPN): See Examples 1(a), 1(b), 2(b), 4, and 5(a), Chapter 9.

### C. Optional Calculations for Computing Feeder and Service Loads

#### 220-30. Optional Calculation — Dwelling Unit.

(a) **Feeder and Service Load.** For a dwelling unit having the total connected load served by a single 3-wire, 120/240-volt or 208Y/120-volt set of service-entrance or feeder conductors with an ampacity of 100 or greater, it shall be permissible to compute the feeder and service loads in accordance with Table 220-30 instead of the method specified in Part B of this article. Feeder and service-entrance conductors whose demand load is determined by this optional calculation shall be permitted to have the neutral load determined by Section 220-22.

(b) **Loads.** The loads identified in Table 220-30 as "other load" and as "remainder of other load" shall include the following:

(1) 1500 volt-amperes for each 2-wire, 20-ampere small appliance branch circuit and each laundry branch circuit specified in Section 220-16.

(2) 3 volt-amperes per square foot (0.093 sq m) for general lighting and general-use receptacles.

(3) The nameplate rating of all fastened in place appliances, ranges, wall-mounted ovens, and counter-top cooking units.

(4) The nameplate ampere or kVA rating of all motors and of all low-power-factor loads.

**Table 220-30**  
**Optional Calculation for Dwelling Unit**  
**Load in kVA**

Largest of the following four selections.

(1) 100 percent of the nameplate rating(s) of the air conditioning and cooling, including heat pump compressors.

(2) 65 percent of the nameplate rating(s) of the central electric space heating including integral supplemental heating in heat pumps.

(3) 65 percent of the nameplate rating(s) of electric space heating if less than four separately controlled units.

(4) 40 percent of the nameplate rating(s) of electric space heating of four or more separately controlled units.

Plus: 100 percent of the first 10 kVA of all other load. 40 percent of the remainder of all other load.

**220-31. Optional Calculation for Additional Loads in Existing Dwelling Unit.** For an existing dwelling unit presently being served by an existing 120/240 volt or 208Y/120, 3-wire service, it shall be permissible to compute load calculations as follows:

Load (in kVA)	Percent of Load
First 8 kVA of load at	100%
Remainder of load at	40%

Load calculation shall include lighting at 3 volt-amperes per square foot (0.093 sq m); 1500 volt-amperes for each 20-ampere appliance circuit; range or wall-mounted oven and counter-mounted cooking unit, and other appliances that are permanently connected or fastened in place, at nameplate rating.

If air-conditioning equipment or electric space heating equipment is to be installed the following formula shall be applied to determine if the existing service is of sufficient size.

Air-conditioning equipment*	100%
Central electric space heating*	100%
Less than four separately controlled space heating units*	100%
First 8 kVA of all other load	100%
Remainder of all other load	40%

Other loads shall include:

1500 volt-amperes for each 20-ampere appliance circuit.

Lighting and portable appliances at 3 volt-amperes per square foot (0.093 sq m)

Household range or wall-mounted oven and counter-mounted cooking unit.

All other appliances fastened in place, including four or more separately controlled space heating units, at nameplate rating.

\* Use larger connected load of air conditioning and space heating, but not both.

### 220-32. Optional Calculation — Multifamily Dwelling.

(a) **Feeder or Service Load.** It shall be permissible to compute the feeder or service load of a multifamily dwelling in accordance with Table 220-32 instead of Part B of this article where all the following conditions are met:

- (1) No dwelling unit is supplied by more than one feeder.
- (2) Each dwelling unit is equipped with electric cooking equipment.

*Exception: When the computed load for multifamily dwellings without electric cooking in Part B of this article exceeds that computed under Part C for the identical load plus electric cooking (based on 8 kW per unit), the lesser of the two loads shall be permitted to be used.*

(3) Each dwelling unit is equipped with either electric space heating or air conditioning or both.

Feeders and service-entrance conductors whose demand load is determined by this optional calculation shall be permitted to have the neutral load determined by Section 220-22.



**(b) House Loads.** House loads shall be computed in accordance with Part B of this article and shall be in addition to the dwelling unit loads computed in accordance with Table 220-32.

**(c) Connected Loads.** The connected load to which the demand factors of Table 220-32 apply shall include the following:

(1) 1500 volt-amperes for each 2-wire, 20-ampere small appliance branch circuit and each laundry branch circuit specified in Section 220-16.

(2) 3 volt-amperes per square foot (0.093 sq m) for general lighting and general-use receptacles.

(3) The nameplate rating of all appliances that are fastened in place, permanently connected or located to be on a specific circuit, ranges, wall-mounted ovens, counter-mounted cooking units, clothes dryers, water heaters, and space heaters.

If water heater elements are so interlocked that all elements cannot be used at the same time, the maximum possible load shall be considered the nameplate load.

(4) The nameplate ampere or kVA rating of all motors and of all low-power-factor loads.

(5) The larger of the air-conditioning load or the space heating load.

**Table 220-32**  
**Optional Calculation — Demand Factors for Three or More**  
**Multifamily Dwelling Units**

Number of Dwelling Units	Demand Factor Percent
3-5	45
6-7	44
8-10	43
11	42
12-13	41
14-15	40
16-17	39
18-20	38
21	37
22-23	36
24-25	35
26-27	34
28-30	33
31	32
32-33	31
34-36	30
37-38	29
39-42	28
43-45	27
46-50	26
51-55	25
56-61	24
62 & over	23

**220-33. Optional Calculation — Two Dwelling Units.** Where two dwelling units are supplied by a single feeder and the computed load under Part B of this article exceeds that for three identical units computed under Section 220-32, the lesser of the two loads shall be permitted to be used.

**220-34. Optional Method — Schools.** The calculation of a feeder or service load for schools shall be permitted in accordance with Table 220-34 in lieu of Part B of this article where equipped with electric space heating, or air conditioning, or both. The connected load to which the demand factors of Table 220-34 apply shall include all of the interior and exterior lighting, power, water heating, cooking, other loads, and the larger of the air-conditioning load or space heating load within the building or structure.

Feeders and service-entrance conductors whose demand load is determined by this optional calculation shall be permitted to have the neutral load determined by Section 220-22. Where the building or structure load is calculated by this optional method, feeders within the building or structure shall have ampacity as permitted in Part B of this article; however, the ampacity of an individual feeder need not be larger than the ampacity for the entire building.

This section shall not apply to portable classroom buildings:

**Table 220-34**

**Optional Method — Demand Factors for Feeders  
and Service-Entrance Conductors for Schools**

Connected Load Volt-Amperes per Square Foot	Demand Factors Percent
Connected load up to and including 3, plus	100
Connected load over 3 and including 20, plus	75
Connected load over 20 at	25

For SI units: one square foot = 0.093 square meter.

**220-35. Optional Calculations for Additional Loads to Existing Installations.** For the purpose of allowing additional loads to be connected to existing feeders and services, it shall be permitted to use actual maximum kVA demand figures to determine the existing load on a service or feeder when all the following conditions are met:

(1) The maximum demand data is available in kVA for a minimum of a one-year period.

(2) The existing demand at 125 percent plus the new load does not exceed the ampacity of the feeder or rating of the service.

(3) The feeder or service has overcurrent protection in accordance with Sections 230-90 and 240-3.

**D. Method for Computing Farm Loads**

**220-40. Farm Loads — Buildings and Other Loads.**

(a) **Dwelling Unit.** The feeder or service load of a farm dwelling unit shall be computed in accordance with the provisions for dwellings in Part B or C of this article.

(b) **Other than Dwelling Unit.** For each farm building or load supplied by two or more branch circuits the load for feeders, service-entrance conductors, and service equipment shall be computed in accordance with demand factors not less than indicated in Table 220-40.

(FPN): See Section 230-21 for overhead conductors from a pole to a building or other structure.

**Table 220-40**  
**Method for Computing Farm Loads for Other Than Dwelling Unit**

Ampere Load at 240 Volts	Demand Factor Percent
Loads expected to operate without diversity, but not less than 125 percent full-load current of the largest motor and not less than the first 60 amperes of load .....	100
Next 60 amperes of all other loads .....	50
Remainder of other load .....	25

**220-41. Farm Loads — Total.** The total load of the farm for service-entrance conductors and service equipment shall be computed in accordance with the farm dwelling unit load and demand factors specified in Table 220-41. Where there is equipment in two or more farm equipment buildings or for loads having the same function, such loads shall be computed in accordance with Table 220-40 and shall be permitted to be combined as a single load in Table 220-41 for computing the total load.

(FPN): See Section 230-21 for overhead conductors from a pole to a building or other structure.

**Table 220-41**  
**Method for Computing Total Farm Load**

Individual Loads Computed in Accordance with Table 220-40	Demand Factor Percent
Largest load .....	100
Second largest load .....	75
Third largest load .....	65
Remaining loads .....	50

To this total load, add the load of the farm dwelling unit computed in accordance with Part B or C of this article.

## **ARTICLE 225 — OUTSIDE BRANCH CIRCUITS AND FEEDERS**

**225-1. Scope.** This article covers electric equipment and wiring located on or attached to the outside of public or private buildings, or run between buildings, other structures, or poles on the premises served.

*Exception: Outside branch circuits and feeders for electrolytic cells as covered in Section 668-3(c), Exceptions No. 1 and 4.*

(FPN): For additional information on wiring over 600 volts, see the National Electrical Safety Code (ANSI C2-1984).

**225-2. Other Articles.** Application of other articles, including additional requirements to specific cases of equipment and conductors, is as follows:

	<b>Article</b>
Branch Circuits .....	210
Class 1, Class 2, and Class 3 Remote Control, Signaling, and Power-Limited Circuits .....	725
Communication Circuits .....	800
Community Antenna Television and Radio Distribution Systems .....	820
Conductors .....	310
Electrically Driven or Controlled Irrigation Machines .....	675
Electric Signs and Outline Lighting .....	600
Feeders .....	215
Fire Protective Signaling Systems .....	760
Fixed Outdoor Electric De-icing and Snow-Melting Equipment .....	426
Fixtures .....	410
Floating Buildings .....	553
Grounding .....	250
Hazardous (Classified) Locations .....	500
Hazardous (Classified) Locations, Specific .....	510
Marinas and Boatyards .....	555
Messenger Supported Wiring .....	321
Open Wiring on Insulators .....	320
Over 600 Volts, General .....	710
Overcurrent Protection .....	240
Radio and Television Equipment .....	810
Services .....	230
Solar Photovoltaic Systems .....	690
Swimming Pools, Fountains and Similar Installations .....	680
Use and Identification of Grounded Conductors .....	200

### **225-3. Calculation of Load.**

(a) **Branch Circuits.** The load on outdoor branch circuits shall be as determined by Section 220-3.

(b) **Feeders.** The load on outdoor feeders shall be as determined by Part B of Article 220.

**225-4. Conductor Covering.** Where within 10 feet (3.05 m) of any building or other structure, open wiring on insulators shall be insulated or covered. Conductors in cables or raceways, except Type MI cable, shall be of the rubber-covered type or thermoplastic type and in wet locations shall comply with Section 310-8. Conductors for festoon lighting shall be of the rubber-covered or thermoplastic type.

*Exception: Equipment grounding conductors.*

**225-5. Size of Conductors.** The ampacity of outdoor branch-circuit and feeder conductors shall be in accordance with Tables 310-16 through 310-31 based on loads as determined under Section 220-3 and Part B of Article 220.

**225-6. Minimum Size of Conductor.**

(a) **Overhead Spans.** Overhead conductors shall not be smaller than the following:

(1) For 600 volts, nominal, or less, No. 10 copper or No. 8 aluminum for spans up to 50 feet (15.2 m) in length and No. 8 copper or No. 6 aluminum for a longer span.

(2) For over 600 volts, nominal, No. 6 copper or No. 4 aluminum where open individual conductors and No. 8 copper or No. 6 aluminum where in cable.

(b) **Festoon Lighting.** Overhead conductors for festoon lighting shall not be smaller than No. 12.

*Exception: Where supported by messenger wires.*

(FPN): See Section 225-24 for outdoor lampholders.

**Definition:** Festoon lighting is a string of outdoor lights suspended between two points more than 15 feet (4.57 m) apart.

**225-7. Lighting Equipment Installed Outdoors.**

(a) **General.** For the supply of lighting equipment installed outdoors, the branch circuits shall comply with Article 210 and (b) through (d) below.

(b) **Common Neutral.** It shall be permissible to use a multiwire branch circuit consisting of the neutral and not more than eight ungrounded conductors. The ampacity of the neutral conductor shall not be less than the calculated sum of the currents in all ungrounded conductors connected to any one phase of the circuit.

(c) **277 Volts to Ground.** Circuits exceeding 120 volts, nominal, between conductors and not exceeding 277 volts, nominal, to ground shall be permitted to supply lighting fixtures for illumination of outdoor areas of industrial establishments, office buildings, schools, stores, and other commercial or public buildings where the fixtures are not less than 3 feet (914 mm) from windows, platforms, fire escapes, and the like.

(d) **600 Volts Between Conductors.** Circuits exceeding 277 volts, nominal, to ground and not exceeding 600 volts, nominal, between conductors shall be permitted to supply the auxiliary equipment of electric-discharge lamps in accordance with Section 210-6(d)(1).

**225-8. Disconnection.** The disconnecting means for branch-circuit and feeder fuses shall be in accordance with Section 240-40.

**225-9. Overcurrent Protection.** Overcurrent protection shall be in accordance with Section 210-20 for branch circuits and Part A of Article 240 for feeders.

**225-10. Wiring on Buildings.** The installation of outside wiring on surfaces of buildings shall be permitted for circuits of not over 600 volts, nominal, as open wiring on insulators, as multiconductor cable, as Type MC cable, as Type MI cable, as messenger supported wiring, in rigid metal conduit, in intermediate metal conduit, in rigid nonmetallic conduit, in cable trays, as

cablebus, in wireways, in auxiliary gutters, in electrical-metallic tubing, in flexible metal conduit, in liquidtight flexible metal conduit, and in busways. Circuits of over 600 volts, nominal, shall be installed as provided in Section 710-3. Circuits for signs and outline lighting shall be installed in accordance with Article 600.

**225-11. Circuit Exits and Entrances.** Where outside branch and feeder circuits leave or enter a building, the requirements of Sections 230-43, 230-52, and 230-54 shall apply.

**225-12. Open-Conductor Supports.** Open conductors shall be supported on glass or porcelain-knobs, racks, brackets, or strain insulators.

**225-13. Festoon Supports.** In spans exceeding 40 feet (12.2 m), the conductors shall be supported by a messenger wire; and the messenger wire shall be supported by strain insulators. Conductors or messenger wires shall not be attached to any fire-escape, downspout, or plumbing equipment.

**225-14. Open-Conductor Spacings.**

(a) **600 Volts, Nominal, or Less.** Conductors of 600 volts, nominal, or less, shall comply with the spacings provided in Table 230-51(c).

(b) **Over 600 Volts, Nominal.** Conductors of over 600 volts, nominal, shall comply with the spacings provided in Part D of Article 710.

(c) **Separation from Other Circuits.** Open conductors shall be separated from open conductors of other circuits or systems by not less than 4 inches (102 mm).

(d) **Conductors on Poles.** Conductors on poles shall have a separation of not less than 1 foot (305 mm) where not placed on racks or brackets. Conductors supported on poles shall provide a horizontal climbing space not less than the following:

Power conductors, below communication conductors .....	30 inches (762 mm)
Power conductors alone or above communication conductors:	
300 volts or less .....	24 inches (610 mm)
Over 300 volts .....	30 inches (762 mm)
Communication conductors below power conductors .....	same as power conductors
Communication conductors alone .....	no requirement

**225-15. Supports Over Buildings.** Supports over a building shall be in accordance with Section 230-29.

**225-16. Point of Attachment to Buildings.** The point of attachment to a building shall be in accordance with Section 230-26.

**225-17. Means of Attachment to Buildings.** The means of attachment to a building shall be in accordance with Section 230-27.

**225-18. Clearance from Ground.** Open conductors of not over 600 volts, nominal, shall conform to the following:

10 feet (3.05 m) — above finished grade; sidewalks, or from any platform

or projection from which they might be reached where the supply conductors are limited to 150 volts to ground and accessible to pedestrians only.

12 feet (3.66 m) — over residential driveways, and those commercial areas not subject to truck traffic where the voltage is limited to 300 volts to ground.

15 feet (4.57 m) — for those areas listed in the 12-foot (3.66-m) classification where the voltage exceeds 300 volts to ground.

18 feet (5.49 m) — over public streets, alleys, roads, parking areas subject to truck traffic, driveways on other than residential property, and other land traversed by vehicles such as cultivated, grazing, forest, and orchard.

(FPN): Note: For clearances of conductors of over 600 volts, see National Electrical Safety Code (ANSI C2-1984).

### **225-19. Clearances from Buildings for Conductors of Not Over 600 Volts, Nominal.**

**(a) Above Roofs.** Conductors not fully insulated for the operating voltage shall have a vertical or diagonal clearance of not less than 10 feet (3.05 m) from the roof surface.

*Exception No. 1: Fully insulated conductors shall be permitted to have vertical or diagonal clearance of 3 feet (914 mm) or more.*

*Exception No. 2: Above roof space accessible to pedestrians. Vertical clearance shall not be less than 15 feet (4.57 m) for uninsulated, 8 feet (2.44 m) for insulated conductors.*

*Exception No. 3: Above roof space accessible to vehicular traffic, vertical clearance shall not be less than 18 feet (5.49 m).*

*Exception No. 4: Where the voltage between conductors does not exceed 300 and the roof has a slope of not less than 4 inches (102 mm) in 12 inches (305 mm), a reduction in clearance to 3 feet (914 mm) shall be permitted.*

*Exception No. 5: Where the voltage between conductors does not exceed 300, a reduction in clearance above only the overhanging portion of the roof to not less than 18 inches (457 mm) shall be permitted if (1) not more than 4 feet (1.22 m) of the conductors pass above the roof overhang, and (2) they are terminated at a through-the-roof raceway or approved support.*

**(b) From Nonbuilding or Nonbridge Structures.** From signs, chimneys, radio and television antennas, tanks, other nonbuilding or nonbridge structures, clearances, vertical, diagonal and horizontal, shall not be less than 5 feet (1.52 m) for uninsulated conductors, 3 feet (914 mm) for insulated conductors.

**(c) Horizontal Clearances.** Clearances shall not be less than 5 feet (1.52 m) for uninsulated conductors, 3 feet (914 mm) for insulated conductors.

**(d) Final Spans.** Final spans of feeders or branch circuits to a building they supply or from which they are fed shall be permitted to be attached to the building, but they shall be kept 3 feet (914 mm) from windows, doors, porches, fire escapes, or similar locations.

*Exception: Conductors run above the top level of a window shall be permitted to be less than the 3 feet (914 mm) requirement above.*

**(e) Zone for Fire Ladders.** Where buildings exceed three stories or 50 feet (15.2 m) in height, overhead lines shall be arranged, where practicable, so that a clear space (or zone) at least 6 feet (1.83 m) wide will be left either adjacent to the buildings or beginning not over 8 feet (2.44 m) from them to facilitate the raising of ladders when necessary for fire fighting.

(FPN): Note: For clearance of conductors over 600 volts, see National Electrical Safety Code (ANSI C2-1984).

**225-20. Mechanical Protection of Conductors.** Mechanical protection of conductors on buildings, structures, or poles shall be as provided for services in Section 230-50.

**225-21. Multiconductor Cables on Exterior Surfaces of Buildings.** Supports for multiconductor cables on exterior surfaces of buildings shall be as provided in Section 230-51.

**225-22. Raceways on Exterior Surfaces of Buildings.** Raceways on exterior surfaces of buildings shall be raintight and arranged to drain.

*Exception: As permitted in Section 350-2.*

**225-23. Underground Circuits.** Underground circuits shall meet the requirements of Section 300-5.

**225-24. Outdoor Lampholders.** Where outdoor lampholders are attached as pendants, the connections to the circuit wires shall be staggered. Where such lampholders have terminals of a type that puncture the insulation and make contact with the conductors, they shall be attached only to conductors of the stranded type.

**225-25. Location of Outdoor Lamps.** Locations of lamps for outdoor lighting shall be below all live conductors, transformers, or other electric utilization equipment.

*Exception No. 1: Where clearances or other safeguards are provided for relamping operations.*

*Exception No. 2: Where equipment is controlled by a disconnecting means that can be locked in the open position.*

**225-26. Live Vegetation.** Live vegetation such as trees shall not be used for support of overhead conductor spans or other electric equipment.

*Exception: For temporary wiring in accordance with Article 305.*

## ARTICLE 230 — SERVICES

**230-1. Scope.** This article covers service conductors and equipment for control and protection of services and their installation requirements.

(FPN): See Diagram 230-1.

### A. General

**230-2. Number of Services.** A building or other structure served shall be supplied by only one service.

Where more than one service is permitted by any of the following



**Diagram 230-1 Services**

General.....	Part A
Overhead Service Drop Conductors.....	Part B
Underground Service-Lateral Conductors.....	Part C
Service-Entrance Conductors.....	Part D
Service Equipment – General.....	Part E
Service Equipment – Disconnecting Means.....	Part F
Service Equipment – Overcurrent Protection.....	Part G
Services over 600 Volts, Nominal.....	Part H

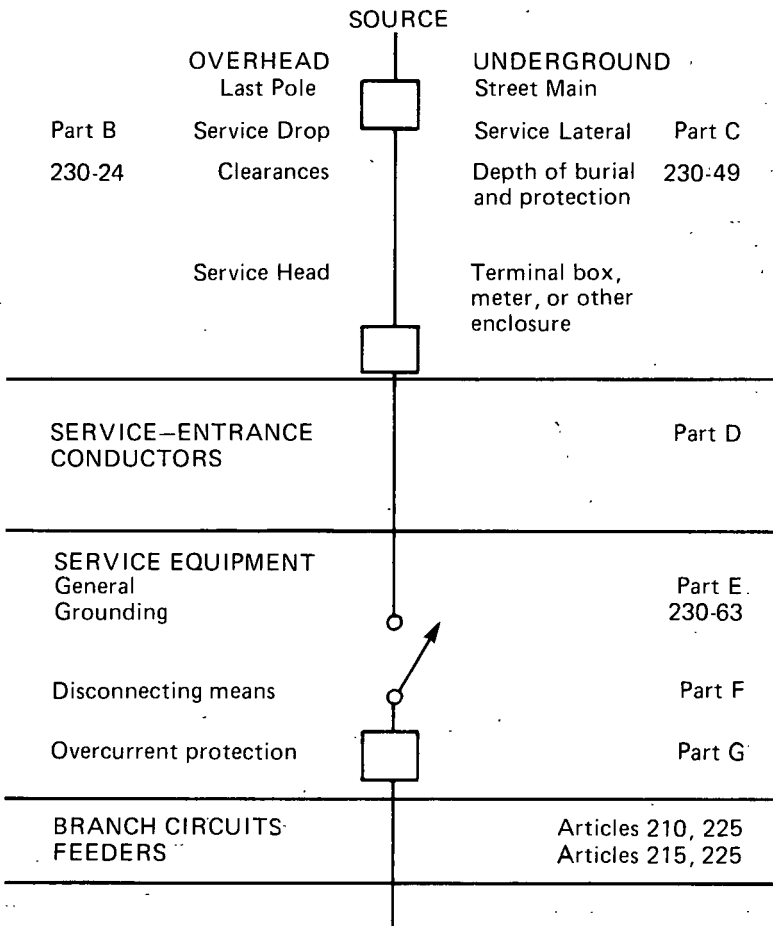

exceptions, a permanent plaque or directory shall be installed at each service drop or lateral or at each service-equipment location denoting all other services on or in that building or structure and the area served by each.

*Exception No. 1: For fire pumps where a separate service is required.*

*Exception No. 2: For emergency, legally required standby, optional standby, or parallel power production systems where a separate service is required.*

*Exception No. 3: Multiple-Occupancy Buildings. By special permission, in multiple-occupancy buildings where there is no available space for service equipment accessible to all the occupants.*

*Exception No. 4: Capacity Requirements. Two or more services shall be permitted:*

*a. Where the capacity requirements are in excess of 3000 amperes at a supply voltage of 600 volts or less; or*

*b. Where the load requirements of a single-phase installation are greater than the serving agency normally supplies through one service; or*

*c. By special permission.*

*Exception No. 5: Buildings of Large Area. By special permission, for a single building or other structure sufficiently large to make two or more services necessary.*

*Exception No. 6: For different characteristics, such as for different voltages, frequencies, or phases, or for different uses, such as for different rate schedules.*

*Exception No. 7: For the purpose of Section 230-40, Exception No. 2, only, underground sets of conductors, size 1/0 and larger, running to the same location and connected together at their supply end but not connected together at their load end shall be considered to be one service lateral.*

**230-3. One Building or Other Structure Not to Be Supplied Through Another.** Service conductors supplying a building or other structure shall not pass through the interior of another building or other structure.

(FPN): See Section 230-6 for masonry-encased conductors considered outside of a building.

**230-6. Conductors Considered Outside of Building.** Conductors shall be considered outside of a building or other structure under any of the following conditions: (1) where installed under not less than 2 inches (50.8 mm) of concrete beneath a building or other structure; (2) where installed within a building or other structure in a raceway that is enclosed by concrete or brick not less than 2 inches (50.8 mm) thick; or (3) installed in a transformer vault conforming to the requirements of Article 450, Part C.

**230-7. Other Conductors in Raceway or Cable.** Conductors other than service conductors shall not be installed in the same service raceway or service-entrance cable.

*Exception No. 1: Grounding conductors.*

*Exception No. 2: Load management control conductors having overcurrent protection.*

**230-8. Raceway Seal.** Where a service raceway enters from an underground distribution system, it shall be sealed in accordance with Section

300-5. Spare or unused raceways shall also be sealed. Sealants shall be identified for use with the cable insulation, shield, or other components.

**230-9. Clearance from Building Openings.** Service conductors installed as open conductors or multiconductor cable without an overall outer jacket shall have a clearance of not less than 3 feet (914 mm) from windows, doors, porches, fire escapes, or similar locations.

*Exception: Conductors run above the top level of a window shall be permitted to be less than the 3 feet (914 mm) requirement above.*

Service conductors shall not be installed beneath openings through which materials may be moved, such as openings in farm and commercial buildings. Overhead wires shall not be run such that they obstruct entrance to these building openings.

### B. Overhead Service-Drop Conductors

**230-21. Overhead Supply.** Overhead conductors to a building or other structure (such as a pole) on which a meter or disconnecting means is installed shall be considered as a service drop and installed accordingly.

(FPN): Example: Farm loads in Part D of Article 220.

**230-22. Insulation or Covering.** Service conductors shall normally withstand exposure to atmospheric and other conditions of use without detrimental leakage of current. Individual conductors shall be insulated or covered with an extruded thermoplastic or thermosetting insulating material.

*Exception: The grounded conductor of a multiconductor cable shall be permitted to be bare.*

### 230-23. Size and Rating.

(a) **General.** Conductors shall have sufficient ampacity to carry the load without a temperature rise detrimental to the covering or insulation of the conductors and shall have adequate mechanical strength.

(b) **Minimum Size.** The conductors shall not be smaller than No. 8 copper, No. 6 aluminum or copper-clad aluminum.

*Exception: For installations to supply only limited loads of a single branch circuit such as small polyphase power, controlled water heaters and the like, they shall not be smaller than No. 12 hard-drawn copper or equivalent.*

(c) **Grounded Conductors.** The grounded (neutral) conductor shall not be less than the minimum size as required by Section 250-23(b).

**230-24. Clearances.** The vertical clearances of all service-drop conductors shall be based on conductor temperature of 60°F (15°C), no wind, with final unloaded sag in the wire, conductor, or cable.

Service-drop conductors shall not be readily accessible and shall comply with (a) through (d) below for services not over 600 volts, nominal.

(a) **Above Roofs.** Conductors shall have a vertical clearance of not less than 8 feet (2.44 m) from all points of roofs above which they pass.

*Exception No. 1: Where the voltage between conductors does not exceed 300 and the roof has a slope of not less than 4 inches (102 mm) in 12 inches (305 mm), a reduction in clearance to 3 feet (914 mm) shall be permitted.*

*Exception No. 2: Where the voltage between conductors does not exceed 300, a reduction in-clearance above only the overhanging portion of the roof to not less than 18 inches (457 mm) shall be permitted if (1) not more than 4 feet (1.22 m) of service-drop conductors pass above the roof overhang, and (2) they are terminated at a through-the-roof raceway or approved support.*

(FPN): See Section 230-28 for mast supports.

*Exception No. 3: The area above a roof surface subject to vehicular traffic shall have a vertical clearance from the roof surface in accordance with the clearance requirements of Section 230-24(b).*

**(b) Vertical Clearance from Ground.** Service-drop conductors where not in excess of 600 volts, nominal, shall have the following minimum clearance from final grade.

10 feet (3.05 m) — at the electric service entrance to buildings, or at the drip loop of the building electric entrance, or above areas or sidewalks accessible only to pedestrians, measured from final grade or other accessible surface only for service-drop cables supported-on and cabled together with a grounded bare messenger and limited to 150 volts to ground.

12 feet (3.66 m) — for those areas listed in the 15 foot (4.57 m) classification when the voltage is limited to 300 volts to ground.

15 feet (4.57 m) — over residential property and driveways, and those commercial areas not subject to truck traffic.

18 feet (5.49 m) — over public streets, alleys, roads, parking areas subject to truck traffic, driveways on other than residential property, and other land traversed by vehicles such as cultivated, grazing, forest, and orchard.

**(c) Clearance from Building Openings.** See Section 230-9.

**(d) Clearance from Swimming Pools.** See Section 680-8.

**230-26. Point of Attachment.** The point of attachment of the service-drop conductors to a building or other structure shall provide the minimum clearances as specified in Section 230-24. In no case shall this point of attachment be less than 10 feet (3.05 m) above finished grade.

**230-27. Means of Attachment.** Multiconductor cables used for service drops shall be attached to buildings or other structures by fittings identified for use with service conductors. Open conductors shall be attached to fittings identified for use with service conductors or to noncombustible, nonabsorbent insulators securely attached to the building or other structure.

**230-28. Service Masts as Supports.** Where a service mast is used for the support of service-drop conductors, it shall be of adequate strength or be supported by braces or guys to withstand safely the strain imposed by the service drop. Where raceway-type service masts are used, all raceway fittings shall be identified for use with service masts.

**230-29. Supports Over Buildings.** Service-drop conductors passing over a roof shall be securely supported by substantial structures. Where practicable, such supports shall be independent of the building.

### C. Underground Service-Lateral Conductors

**230-30. Insulation.** Service-lateral conductors shall withstand exposure to atmospheric and other conditions of use without detrimental leakage of current. Service-lateral conductors shall be insulated for the applied voltage.

*Exception: A grounded conductor shall be permitted to be uninsulated as follows:*

a. *Bare copper used in a raceway.*

b. *Bare copper for direct burial where bare copper is judged to be suitable for the soil conditions.*

c. *Bare copper for direct burial without regard to soil conditions where part of a cable assembly identified for underground use.*

d. *Aluminum or copper-clad aluminum without individual insulation or covering where part of a cable assembly identified for underground use in a raceway or for direct burial.*

### 230-31. Size and Rating.

(a) **General.** Service-lateral conductors shall have sufficient ampacity to carry the current for the load as computed in accordance with Article 220 and shall have adequate mechanical strength.

(b) **Minimum Size.** The conductors shall not be smaller than No. 8 copper or No. 6 aluminum or copper-clad aluminum.

*Exception: For installations to supply only limited loads of a single branch circuit such as small polyphase power, controlled water heaters and the like, they shall not be smaller than No. 12 copper or No. 10 aluminum or copper-clad aluminum.*

(c) **Grounded Conductors.** The grounded (neutral) conductor shall not be less than the minimum size required by Section 250-23(b).

(FPN): Reasonable efficiency of operation can be provided when voltage drop is taken into consideration in sizing the service-lateral conductors.

**230-32. Protection Against Damage.** Underground service-lateral conductors shall be protected against damage in accordance with Section 300-5. Service-lateral conductors entering a building shall be installed in accordance with Section 230-6 or protected by a raceway wiring method identified in Section 230-43.

### D. Service-Entrance Conductors

**230-40. Number of Service-Entrance Conductor Sets.** Each service drop or lateral shall supply only one set of service-entrance conductors.

*Exception No. 1: Buildings with more than one occupancy shall be permitted to have one set of service-entrance conductors run to each occupancy or to a group of occupancies.*

*Exception No. 2: Where two to six service disconnecting means in separate enclosures are grouped at one location and supply separate loads from one service drop or lateral, one set of service-entrance conductors shall be permitted to supply each or several such service equipment enclosures.*

**230-41. Insulation of Service-Entrance Conductors.** Service-entrance conductors shall normally withstand exposure to atmospheric and other conditions of use without detrimental leakage of current. Service-entrance conductors entering or on the exterior of buildings or other structures shall be insulated.

*Exception: A grounded conductor shall be permitted to be uninsulated as follows:*

- a. Bare copper used in a raceway or part of a service cable assembly.
- b. Bare copper for direct burial where bare copper is judged to be suitable for the soil conditions.
- c. Bare copper for direct burial without regard to soil conditions when part of a cable assembly identified for underground use.
- d. Aluminum or copper-clad aluminum without individual insulation or covering when part of a cable assembly or identified for underground use in a raceway or for direct burial.

**230-42. Size and Rating.**

(a) **General.** Service-entrance conductors shall be of sufficient size to carry the loads as computed in Article 220. Ampacity shall be determined from Tables 310-16 through 310-31 and all applicable notes to these tables.

(b) **Ungrounded Conductors.** Ungrounded conductors shall have an ampacity of not less than:

- (1) 100 ampere for a 3-wire service to a one-family dwelling with six or more 2-wire branch circuits.
- (2) 100 ampere for a 3-wire service to a one-family dwelling with an initial net computed load of 10 kVA or more.
- (3) 60 amperes for other loads.

*Exception No. 1: For loads consisting of not more than two 2-wire branch circuits, No. 8 copper or No. 6 aluminum or copper-clad aluminum.*

*Exception No. 2: By special permission, for loads limited by demand or by the source of supply, No. 8 copper or No. 6 aluminum or copper-clad aluminum.*

*Exception No. 3: For limited loads of a single branch circuit, No. 12 copper or No. 10 aluminum or copper-clad aluminum, but in no case smaller than the branch-circuit conductors.*

(c) **Grounded Conductors.** The grounded (neutral) conductor shall not be less than the minimum size as required by Section 250-23(b).

**230-43. Wiring Methods for 600 Volts, Nominal, or Less.** Service-entrance conductors shall be installed in accordance with the applicable requirements of this Code covering the type of wiring method used and limited to the following methods: (1) open wiring on insulators; (2) rigid metal conduit; (3) intermediate metal conduit; (4) electrical metallic tubing; (5) service-entrance cables; (6) wireways; (7) busways; (8) auxiliary gutters; (9) rigid nonmetallic conduit; (10) cablebus; (11) Type MC cable; (12) mineral-insulated, metal-sheathed cable; or (13) flexible metal conduit not over 6 feet (1.83 m) long between raceways, or between raceway and service equipment, with equipment bonding jumper installed around the flexible metal conduit according to provisions of Section 250-79(a), (b), (c), and (e). Also see Section 350-2.

Approved cable tray systems shall be permitted to support cables approved for use as service-entrance conductors. See Article 318.

**230-46. Unspliced Conductors.** Service-entrance conductors shall not be spliced.

*Exception No. 1: Clamped or bolted connections in metering equipment enclosures shall be permitted.*

*Exception No. 2: Where service-entrance conductors are tapped to supply two to six disconnecting means grouped at a common location.*

*Exception No. 3: At a properly enclosed junction point where an underground wiring method is changed to another type of wiring method.*

*Exception No. 4: A connection shall be permitted where service conductors are extended from a service drop to an outside meter location and returned to connect to the service-entrance conductors of an existing installation.*

*Exception No. 5: When the service-entrance conductors consist of busway, connections shall be permitted as required to assemble the various sections and fittings.*

**230-49. Protection Against Physical Damage — Underground.** Underground service-entrance conductors shall be protected against physical damage in accordance with Section 300-5.

**230-50. Protection of Open Conductors and Cables Against Damage — Aboveground.** Service-entrance conductors installed aboveground shall be protected against physical damage as specified in (a) or (b) below.

**(a) Service-Entrance Cables.** Service-entrance cables, where subject to physical damage, such as where installed in exposed places near driveways or coal chutes, or where subject to contact with awnings, shutters, swinging signs, or similar objects, shall be protected in any of the following ways: (1) by rigid metal conduit; (2) by intermediate metal conduit; (3) by rigid nonmetallic conduit suitable for the location; (4) by electrical metallic tubing; or (5) by other approved means.

**(b) Other than Service-Entrance Cable.** Individual open conductors and cables other than service-entrance cables shall not be installed within 10 feet (3.05 m) of grade level or where exposed to physical damage.

**230-51. Mounting Supports.** Cables or individual open service conductors shall be supported as specified in (a), (b), or (c) below.

**(a) Service-Entrance Cables.** Service-entrance cables shall be supported by straps or other approved means within 12 inches (305 mm) of every service head, gooseneck, or connection to a raceway or enclosure and at intervals not exceeding 30 inches (762 mm).

**(b) Other Cables.** Cables that are not approved for mounting in contact with a building or other structure shall be mounted on insulating supports installed at intervals not exceeding 15 feet (4.57 m) and in a manner that will maintain a clearance of not less than 2 inches (50.8 mm) from the surface over which they pass.

**(c) Individual Open Conductors.** Individual open conductors shall be installed in accordance with Table 230-51(c). Where exposed to the weather, the conductors shall be mounted on insulators or on insulating supports

attached to racks, brackets, or other approved means. Where not exposed to the weather, the conductors shall be mounted on glass or porcelain knobs.

**Table 230-51(c). Supports and Clearances for Individual Open Service Conductors:**

Maximum Volts	Maximum Distance In Feet Between Supports	Minimum Clearances In Inches	
		Between Conductors	From Surface
600	9	6	2
600	15	12	2
300	4½	3	2
600*	4½*	2½*	1*

For SI units: one inch = 25.4 millimeters; one foot = 0.3048 meter.

\* Where not exposed to weather.

### 230-52. Individual Conductors Entering Buildings or Other Structures.

Where individual open conductors enter a building or other structure, they shall enter through roof bushings or through the wall in an upward slant through individual, noncombustible, nonabsorbent insulating tubes. Drip loops shall be formed on the conductors before they enter the tubes.

**230-53. Raceways to Drain.** Where exposed to the weather, raceways enclosing service-entrance conductors shall be raintight and arranged to drain. Where embedded in masonry, raceways shall be arranged to drain.

### 230-54. Connections at Service Head.

(a) **Raintight Service Head.** Service raceways shall be equipped with a raintight service head at the point of connection to service-drop conductors.

(b) **Service Cable Equipped with Raintight Service Head or Gooseneck.** Service cables, either (1) unless continuous from pole to service equipment or meter, shall be equipped with a raintight service head, or (2) formed in a gooseneck and taped and painted or taped with a self-sealing, weather-resistant thermoplastic.

(c) **Service Heads Above Service-Drop Attachment.** Service heads and goosenecks in service-entrance cables shall be located above the point of attachment of the service-drop conductors to the building or other structure.

*Exception: Where it is impracticable to locate the service head above the point of attachment, the service head location shall be permitted not farther than 24 inches (610 mm) from the point of attachment.*

(d) **Secured.** Service cables shall be held securely in place.

(e) **Opposite Polarity Through Separately Bushed Holes.** Service heads shall have conductors of opposite polarity brought out through separately bushed holes.

(f) **Drip Loops.** Drip loops shall be formed on individual conductors. To prevent the entrance of moisture, service-entrance conductors shall be connected to the service-drop conductors either (1) below the level of the



service head, or (2) below the level of the termination of the service-entrance cable sheath.

(g) **Arranged that Water Will Not Enter Service Raceway or Equipment.** Service-drop conductors and service-entrance conductors shall be arranged so that water will not enter service raceway or equipment.

**230-55. Termination at Service Equipment.** Any service raceway or cable shall terminate at the inner end in a box, cabinet, or equivalent fitting that effectively encloses all live metal parts.

*Exception: Where the service disconnecting means is mounted on a switchboard having exposed busbars on the back, a raceway shall be permitted to terminate at a bushing.*

**230-56. Service-Entrance Conductor with the Higher Voltage-to-Ground.** On a 4-wire delta-connected service where the midpoint of one phase is grounded, the service-entrance conductor having the higher phase voltage-to-ground shall be durably and permanently marked by an outer finish that is orange in color or by other effective means.

### E. Service Equipment — General

**230-62. Service Equipment — Enclosed or Guarded.** Live parts of service equipment shall be enclosed as specified in (a) below, or guarded as specified in (b) below.

(a) **Enclosed.** Live parts shall be enclosed so that they will not be exposed to accidental contact or guarded as in (b) below.

(b) **Guarded.** Live parts that are not enclosed shall be installed on a switchboard, panelboard, or control board and guarded in accordance with Sections 110-17 and 110-18. Such an enclosure shall be provided with means for locking or sealing doors giving access to live parts.

**230-63. Grounding and Bonding.** Service equipment, raceways, cable armor, cable sheaths, etc., and any service conductor that is to be grounded shall be grounded in accordance with the following parts of Article 250.

Part B. Circuit and System Grounding.

Part C. Location of System Grounding Connections.

Part D. Enclosure Grounding.

Part F. Methods of Grounding.

Part G. Bonding.

Part H. Grounding Electrode Systems.

Part J. Grounding Conductors.

**230-64. Working Space.** Sufficient working space shall be provided in the vicinity of the service equipment to permit safe operation, inspection, and repairs. In no case shall this be less than that specified by Section 110-16.

**230-65. Available Short-Circuit Current.** Service equipment shall be suitable for the short-circuit current available at its supply terminals.

### F. Service Equipment — Disconnecting Means

**230-70. General.** Means shall be provided to disconnect all conductors in a building or other structure from the service-entrance conductors.

(a) **Location.** The service disconnecting means shall be installed either inside or outside of a building or other structure at a readily accessible location nearest the point of entrance of the service conductors.

(b) **Marking.** Each service disconnecting means shall be permanently marked to identify it as a service disconnecting means.

(c) **Suitable For Use.** Each service disconnecting means shall be suitable for the prevailing conditions. Service equipment installed in hazardous (classified) locations shall comply with the requirements of Articles 500 through 517.

### 230-71. Maximum Number of Disconnects.

(a) **General.** The service disconnecting means for each service permitted by Section 230-2, or for each set of service-entrance conductors permitted by Section 230-40, Exception No. 1, shall consist of not more than six switches or six circuit breakers mounted in a single enclosure, in a group of separate enclosures, or in or on a switchboard. There shall be no more than six disconnects per service grouped in any one location.

*Exception: For the purpose of this section, disconnecting means used solely for the control circuit of the ground-fault protection system, installed as part of the listed equipment, shall not be considered a service disconnecting means.*

(b) **Single-Pole Units:** Two or three single-pole switches or breakers, capable of individual operation, shall be permitted on multiwire circuits, one pole for each ungrounded conductor, as one multipole disconnect provided they are equipped with "handle ties" or a "master handle" to disconnect all conductors of the service with no more than six operations of the hand.

(FPN): See Section 384-16(a) for service equipment in panelboards.

### 230-72. Grouping of Disconnects.

(a) **General.** The two to six disconnects as permitted in Section 230-71 shall be grouped. Each disconnect shall be marked to indicate the load served.

*Exception: One of the two to six service disconnecting means permitted in Section 230-71, when used only for a water pump also intended to provide fire protection, shall be permitted to be located remote from the other disconnecting means.*

(b) **Additional Service Disconnecting Means.** The one or more additional service disconnecting means for fire pumps or for emergency, legally required standby; or optional standby services permitted by Section 230-2 shall be installed sufficiently remote from the one to six service disconnecting means for normal service to minimize the possibility of simultaneous interruption of supply.

(FPN): See Section 700-12(d) and (e) for emergency system services.

(c) **Access to Occupants.** In a multiple-occupancy building, each occupant shall have access to the occupant's service disconnecting means.

*Exception: In a multiple-occupancy building where electric service and electrical maintenance are provided by the building management and where these are under continuous building management supervision, the service disconnecting means supplying more than one occupancy shall be permitted to be accessible to authorized management personnel only.*

**230-74. Simultaneous Opening of Poles.** Each service disconnecting means shall simultaneously disconnect all ungrounded service conductors from the premises wiring system.

**230-75. Disconnection of Grounded Conductor.** Where the service disconnecting means does not disconnect the grounded conductor from the premises wiring, other means shall be provided for this purpose in the service equipment. A terminal or bus to which all grounded conductors can be attached by means of pressure connectors shall be permitted for this purpose.

**230-76. Manually or Power Operable.** The service disconnecting means for ungrounded service conductors shall consist of either (1) a manually operable switch or circuit breaker equipped with a handle or other suitable operating means, or (2) a power-operated switch or circuit breaker provided the switch or circuit breaker can be opened by hand in the event of a power supply failure.

**230-77. Indicating.** The service disconnecting means shall plainly indicate whether it is in the open or closed position.

**230-78. Externally Operable.** An enclosed service disconnecting means shall be externally operable without exposing the operator to contact with live parts.

*Exception: A power-operated switch or circuit breaker shall not be required to be externally operable by hand to a closed position.*

**230-79. Rating of Disconnect.** The service disconnecting means shall have a rating not less than the load to be carried, determined in accordance with Article 220. In no case shall the rating be lower than specified in (a), (b), (c), or (d) below.

**(a) One-Circuit Installation.** For installations to supply only limited loads of a single branch circuit, the service disconnecting means shall have a rating of not less than 15 amperes.

**(b) Two-Circuit Installations.** For installations consisting of not more than two 2-wire branch circuits, the service disconnecting means shall have a rating of not less than 30 amperes.

**(c) One-Family Dwelling.** For a one-family dwelling, the service disconnecting means shall have a rating of not less than 100 amperes, 3-wire under either of the following conditions: (1) where the initial computed load is 10 kVA or more, or (2) where the initial installation consists of six or more 2-wire branch circuits.

**(d) All Others.** For all other installations the service disconnecting means shall have a rating of not less than 60 amperes.

**230-80. Combined Rating of Disconnects.** Where the service disconnecting means consists of more than one switch or circuit breaker, as permitted by Section 230-71, the combined ratings of all the switches or circuit breakers used shall not be less than the rating required for a single switch or circuit breaker.

**230-81. Connection to Terminals.** The service conductors shall be connected to the service disconnecting means by pressure connectors, clamps,

or other approved means. Connections that depend upon solder shall not be used.

**230-82. Equipment Connected to the Supply Side of Service Disconnect.** Equipment shall not be connected to the supply side of the service disconnecting means.

*Exception No. 1: Cable limiters or other current-limiting devices.*

*Exception No. 2: Fuses and disconnecting means, or circuit breakers suitable for use as service equipment, in meter pedestals or otherwise provided and connected in series with the ungrounded service conductors and located away from the building supplied.*

*Exception No. 3: Meters nominally rated not in excess of 600 volts, provided all metal housings and service enclosures are grounded in accordance with Article 250.*

*Exception No. 4: Instrument transformers (current and voltage), high-impedance shunts, surge-protective devices identified for use on the supply side of the service disconnect, load management devices, and surge arresters.*

*Exception No. 5: Taps used only to supply load management devices, circuits for emergency systems, stand-by power systems, fire pump equipment, and fire and sprinkler alarms if provided with service equipment and installed in accordance with requirements for service-entrance conductors.*

*Exception No. 6: Interconnected electric power production sources. See Article 690.*

*Exception No. 7: Where the service disconnecting means is power operable, the control circuit shall be permitted to be connected ahead of the service disconnecting means if suitable overcurrent protection and disconnecting means are provided.*

*Exception No. 8: Ground-fault protection systems where installed as part of listed equipment, if suitable overcurrent protection and disconnecting means are provided.*

**230-83. Transfer Equipment.** Transfer equipment shall operate such that all ungrounded conductors of one source of supply are disconnected before any ungrounded conductors of the second source are connected.

*Exception No. 1: Where manual equipment identified for the purpose, or suitable automatic equipment is utilized, two or more sources shall be permitted to be connected in parallel through transfer equipment.*

*Exception No. 2: Where parallel operation is used and suitable automatic or manual control equipment is provided.*

**230-84. More than One Building or Other Structure.**

**(a) Disconnect Required for Each.** Where more than one building or other structure is on the same property and under single management, each building or other structure served shall be provided with means for disconnecting all ungrounded conductors.

Location shall be in accordance with Section 230-70.

*Exception No. 1: For large capacity multibuilding industrial installations under single management, where it is assured that the disconnecting can be accomplished by establishing and maintaining safe switching procedures,*

*the disconnecting means shall be permitted to be located elsewhere on the premises. See Section 230-91(b).*

*Exception No. 2: Buildings or other structures qualifying under the provisions of Article 685.*

**(b) Suitable for Service Equipment.** The disconnecting means specified in (a) above shall be suitable for use as service equipment.

*Exception: For garages and outbuildings on residential property, a snap switch or a set of 3-way or 4-way snap switches suitable for use on branch circuits shall be permitted as the disconnecting means.*

### G. Service Equipment — Overcurrent Protection

**230-90. Where Required.** Each ungrounded service conductor shall have overload protection.

**(a) Ungrounded Conductor.** Such protection shall be provided by an overcurrent device in series with each ungrounded service conductor having a rating or setting not higher than the allowable ampacity of the conductor.

*Exception No. 1: For motor-starting currents, ratings in conformity with Sections 430-52, 430-62, and 430-63 shall be permitted.*

*Exception No. 2: Fuses and circuit breakers with a rating or setting in conformity with Section 240-3, Exception No. 1, and Section 240-6.*

*Exception No. 3: Not more than six circuit breakers or six sets of fuses shall be considered as the overcurrent device.*

*Exception No. 4: Fire Pumps. Where the service to the fire pump room is judged to be outside of buildings, these provisions shall not apply. Overcurrent protection for fire pump services shall be selected or set to carry locked-rotor current of the motor(s) indefinitely.*

(FPN): See NFPA 20-1983 (ANSI), Standard for Centrifugal Fire Pumps.

A set of fuses shall be considered all the fuses required to protect all the ungrounded conductors of a circuit. Single-pole circuit breakers, grouped in accordance with Section 230-71(b), shall be considered as one protective device.

**(b) Not in Grounded Conductor.** No overcurrent device shall be inserted in a grounded service conductor except a circuit breaker which simultaneously opens all conductors of the circuit.

**230-91. Location of Overcurrent Protection.**

**(a) General.** The service overcurrent device shall be an integral part of the service disconnecting means or shall be located immediately adjacent thereto.

**(b) More than One Building.** In a property comprising more than one building under single management, the ungrounded conductors supplying each building served shall be protected by overcurrent devices, which may be located in the building served or in another building on the same property, provided they are accessible to the occupants of the building served.

**(c) Access to Occupants.** In a multiple-occupancy building each occupant shall have access to the overcurrent protective devices.

*Exception: As permitted in Section 240-24(b), Exception.*

**230-92. Locked Service Overcurrent Devices.** Where the service overcurrent devices are locked or sealed, or otherwise not readily accessible, branch-circuit overcurrent devices shall be installed on the load side; shall be mounted in an accessible location, and shall be of lower rating than the service overcurrent device.

**230-93. Protection of Specific Circuits.** Where necessary to prevent tampering, an automatic overcurrent device protecting service conductors supplying only a specific load, such as a water heater, shall be permitted to be locked or sealed where located so as to be accessible.

**230-94. Relative Location of Overcurrent Device and Other Service Equipment.** The overcurrent device shall protect all circuits and devices.

*Exception No. 1: The service switch shall be permitted on the supply side.*

*Exception No. 2: High-impedance shunt circuits, lightning arresters, surge protective capacitors, and instrument transformers (current and voltage) shall be permitted to be connected and installed on the supply side of the service disconnecting means as permitted in Section 230-82.*

*Exception No. 3: Circuits for emergency supply and load management devices shall be permitted to be connected on the supply side of the service overcurrent device where separately provided with overcurrent protection.*

*Exception No. 4: Circuits used only for the operation of fire alarm, other protective signaling systems, or the supply to fire pump equipment shall be permitted to be connected on the supply side of the service overcurrent device where separately provided with overcurrent protection.*

*Exception No. 5: Meters nominally rated not in excess of 600 volts, provided all metal housings and service enclosures are grounded in accordance with Article 250.*

*Exception No. 6: Where service equipment is power operable, the control circuit shall be permitted to be connected ahead of the service equipment if suitable overcurrent protection and disconnecting means are provided.*

**230-95. Ground-Fault Protection of Equipment.** Ground-fault protection of equipment shall be provided for solidly grounded wye electrical services of more than 150 volts to ground, but not exceeding 600 volts phase-to-phase for each service disconnecting means rated 1000 amperes or more.

**(a) Setting.** The ground-fault protection system shall operate to cause the service disconnecting means to open all ungrounded conductors of the faulted circuit. The maximum setting of the ground-fault protection shall be 1200 amperes and the maximum time delay shall be one second for ground-fault currents equal to or greater than 3000 amperes.

*Exception No. 1: The provisions of this section shall not apply to a service disconnecting means for a continuous industrial process where a nonorderly shutdown will introduce additional or increased hazards.*

*Exception No. 2: The provisions of this section shall not apply to fire pumps.*

**(b) Fuses.** If a switch and fuse combination is used, the fuses employed shall be capable of interrupting any current higher than the interrupting capacity of the switch during a time when the ground-fault protective system will not cause the switch to open.

(FPN): As used in this section, the rating of the Service Disconnecting Means is considered to be the rating of the largest fuse that can be installed or the highest trip setting for which the actual overcurrent device installed in a circuit breaker is rated or can be adjusted.

(FPN): It is recognized that ground-fault protection may be desirable for service disconnecting means rated less than 1000 amperes on solidly grounded wye systems having more than 150 volts to ground, not exceeding 600 volts phase-to-phase.

(FPN): As used in this section, solidly grounded means that the grounded conductor (neutral) is grounded without inserting any resistor or impedance device.

(FPN): Ground-fault protection that functions to open the service disconnecting means will afford no protection from faults on the line side of the protective element. It serves only to limit damage to conductors and equipment on the load side in the event of an arcing ground fault on the load side of the protective element.

(FPN): This added protective equipment at the service equipment will make it necessary to review the overall wiring system for proper selective overcurrent protection coordination. Additional installations of ground-fault protective equipment will be needed on feeders and branch circuits where maximum continuity of electrical service is necessary.

(FPN): Where ground-fault protection is provided for the service disconnecting means and interconnection is made with another supply system by a transfer device, means or devices may be needed to assure proper ground-fault sensing by the ground-fault protection equipment.

**(c) Performance Testing.** The ground-fault protection system shall be performance tested when first installed on site. The test shall be conducted in accordance with instructions which shall be provided with the equipment. A written record of this test shall be made and shall be available to the authority having jurisdiction:

#### H. Services Exceeding 600 Volts, Nominal

**230-200. General.** Service conductors and equipment used on circuits exceeding 600 volts, nominal, shall comply with all applicable provisions of the preceding sections of this article and with the following sections, which supplement or modify the preceding sections. In no case shall the provisions of this article apply to equipment on the supply side of the service-point.

**Service-Point.** Service-point is the point of connection between the facilities of the serving utility and the premises' wiring.

(FPN): For clearances of conductors of over 600 volts, nominal, see National Electrical Safety Code (ANSI C2-1984).

**230-201. Service Conductors.** The conductors from the service-point to the service disconnecting means shall be considered service conductors regardless of whether they are on the primary or secondary side of a step-down transformer.

**230-202. Service-Entrance Conductors.** Service-entrance conductors to buildings or enclosures shall be installed to conform to the following:

**(a) Conductor Size.** Service-entrance conductors shall not be smaller than No. 6 unless in cable. Conductors in cable shall not be smaller than No. 8.

**(b) Wiring Methods.** Service-entrance conductors shall be installed by means of one of the following wiring methods: (1) in rigid metal conduit; (2) in intermediate metal conduit; (3) in rigid nonmetallic conduit; (4) as multiconductor cable identified as service cable; (5) as open conductors where supported on insulators and where either accessible only to qualified persons or where effectively guarded against accidental contact; (6) in cablebus; or (7) in busways.

Underground service-entrance conductors shall conform to Section 710-3(b).

Cable tray systems shall be permitted to support cables identified as service-entrance conductors. See Article 318.

(FPN): See Section 310-6 for shielding of solid dielectric insulated conductors.

**(c) Open Work.** Open wire services over 600 volts, nominal, shall be installed in accordance with the provisions of Article 710, Part D.

**(d) Supports.** Service-entrance conductors and their supports, including insulators, shall have strength and stability sufficient to ensure maintenance of adequate clearance with abnormal currents in case of short circuits.

**(e) Guarding.** Open wires shall be guarded to make them accessible only to qualified persons.

**(f) Service Cable.** Where cable conductors emerge from a metal sheath or raceway, the insulation of the conductors shall be protected from moisture and physical damage by a pothead or other approved means.

**(g) Draining Raceways.** Unless conductors identified for use in wet locations are used, raceways embedded in masonry or exposed to the weather shall be arranged to drain.

**(h) Over 15,000 Volts.** Where the voltage exceeds 15,000 volts between conductors they shall enter either metal-enclosed switchgear or a transformer vault conforming to the requirements of Sections 450-41 through 450-48.

**230-203. Warning Signs.** Signs with the words "Danger High Voltage Keep Out" shall be posted in plain view where unauthorized persons might come in contact with live parts.

#### **230-204. Isolating Switches.**

**(a) Where Required.** Where oil switches or air or oil circuit breakers constitute the service disconnecting means, an air-break isolating switch shall be installed on the supply side of the disconnecting means and all associated service equipment.

*Exception: Where such equipment is mounted on removable truck panels or metal-enclosed switchgear units, which cannot be opened unless the circuit is disconnected, and which, when removed from the normal operating position, automatically disconnect the circuit breaker or switch from all live parts.*

**(b) Fuses as Isolating Switch.** Where fuses are of the type that can be operated as a disconnecting switch, a set of such fuses shall be permitted as the isolating switch where: (1) the oil disconnecting means is a nonautomatic switch, and (2) the set of fuses disconnect the oil switch and all associated service equipment from the service-entrance conductors.

**(c) Accessible to Qualified Persons Only.** The isolating switch shall be accessible to qualified persons only.



**(d) Grounding Connection.** Isolating switches shall be provided with a means for readily connecting the load side conductors to ground when disconnected from the source of supply.

A means for grounding the load side conductors need not be provided for any duplicate isolating switch installed and maintained by the electric supply company.

### **230-205. Disconnecting Means.**

**(a) Location.** The service disconnecting means shall be located in accordance with Section 230-70 or Section 230-208(b).

*Exception: Where under single management, the service disconnecting means shall be permitted to be located in a separate building or structure on the same premises. In such case the service disconnecting means shall be capable of being electrically opened by a readily accessible control device located as near as practicable to where the service conductors enter the building served. The control device shall be permanently marked to identify its function and shall provide visual indication of the On or Off status of the remote service disconnect.*

(FPN): See Sections 230-3, 230-6, 230-70, 230-71(a) and 230-200.

**(b) Type:** The service disconnecting means shall simultaneously disconnect all ungrounded conductors and shall be capable of being closed on a fault equal to or greater than the maximum available short-circuit current in the circuit at its supply terminals.

Where fused switches or separately mounted fuses are installed, the fuse characteristics shall be permitted to contribute to the fault-closing rating of the disconnecting means.

**230-206. Overcurrent Devices as Disconnecting Means.** Where the circuit breaker or alternative for it specified in Section 230-208 for service overcurrent devices meets the requirements specified in Section 230-205, they shall constitute the service disconnecting means.

**230-207. Equipment in Secondaries.** Where the primary service equipment supplies one or more transformers whose secondary windings connect to a common bus of bars or wires, and the primary load-interrupter switch or circuit breaker is capable of being opened and closed from a point outside the transformer vault, the disconnecting means and overcurrent protection shall not be required in the secondary circuit if the primary fuse or circuit breaker is rated or set to protect the secondary circuit.

**230-208. Overcurrent Protection Requirements.** Service-entrance conductors shall have a short-circuit protective device in each ungrounded conductor, on the load side of, or as an integral part of, the service-entrance switch. The protective device shall be capable of detecting and interrupting all values of current in excess of its trip setting or melting point, which can occur at its location. A fuse rated in continuous amperes not to exceed three times the ampacity of the conductor, or a circuit breaker with a trip setting of not more than six times the ampacity of the conductors shall be considered as providing the required short-circuit protection.

(FPN): See Tables 310-69 through 310-84 for ampacity of high-voltage conductors.

Overcurrent devices shall conform to the following:

(a) **In Vault or Consisting of Metal-Enclosed Switchgear.** Where the service equipment is installed in a transformer vault meeting the provisions of Sections 450-41 through 450-48, or consists of metal-enclosed switchgear, the overcurrent protection and disconnecting means shall be one of the following:

(1) A nonautomatic oil switch, oil fuse cutout, or air load-interrupter switch shall be permitted with fuses. The interrupting rating of this switch shall equal or exceed the continuous current rating of the fuse.

(2) An automatic trip circuit breaker of suitable current-carrying and interrupting capacity.

(3) A switch capable of interrupting the no-load current of the transformer supplied through the switch and suitable fuses shall be permitted provided the switch is interlocked with a single switch or circuit breaker on the secondary circuit of the transformer so that the primary switch cannot be opened when the secondary circuit is closed.

(b) **Not in Vault or Not Consisting of Metal-Enclosed Switchgear.** Where the service equipment is not in a vault or metal-enclosed switchgear, the overcurrent protection and disconnecting means shall be either of the following:

(1) An air load-interrupter switch or other switch capable of interrupting the rated circuit load shall be permitted with fuses on a pole or elevated structure outside the building provided the switch is operable by persons using the building.

(2) An automatic-trip circuit breaker of suitable ampacity and interrupting capacity. The circuit breaker shall be located outside the building as near as practicable to where the service conductors enter the building. The location shall be permitted on a pole, roof, foundation, or other structure.

(c) **Fuses.** Fuses shall have an interrupting rating no less than the maximum available short-circuit current in the circuit at their supply terminals.

(d) **Circuit Breakers.** Circuit breakers shall be free to open in case the circuit is closed on an overload. This can be accomplished by means such as trip-free circuit breakers. A service circuit breaker shall indicate clearly whether it is open or closed, and shall have an interrupting rating no less than the maximum available short-circuit current at its supply terminals.

Overcurrent relays shall be furnished in connection with current transformers in one of the following combinations:

(1) Three overcurrent relays operated from current transformers in each phase.

(2) Two overcurrent relays operated by current from current transformers in any two phases and one overcurrent relay sensitive to ground-fault current that is operated by the sum of the currents from current transformers in each phase.

(3) Two overcurrent relays operated by current from current transformers in any two phases and one overcurrent relay sensitive to ground-fault current that is operated from a current transformer which links all three phase conductors and the grounded circuit conductor (neutral), if provided.

(e) **Enclosed Overcurrent Devices.** The restriction to 80 percent of rating for an enclosed overcurrent device on continuous loads shall not apply to overcurrent devices installed in services operating at over 600 volts.

**230-209. Surge Arresters (Lightning Arresters).** Surge arresters installed in accordance with the requirements of Article 280 shall be placed on each ungrounded overhead service conductor on the supply side of the service equipment, when called for by the authority having jurisdiction.

**230-210. Service Equipment-General Provisions.** Service equipment including instrument transformers shall conform to Article 710, Part B.

**230-211. Metal-Enclosed Switchgear.** Metal-enclosed switchgear shall consist of a substantial metal structure and a sheet metal enclosure. Where installed over a wood floor, suitable protection thereto shall be provided.

## ARTICLE 240 — OVERCURRENT PROTECTION

**240-1. Scope.** Parts A through G of this article provide the general requirements for overcurrent protection and overcurrent protective devices not more than 600 volts, nominal. Part H covers overcurrent protection over 600 volts, nominal.

(FPN): Overcurrent protection for conductors and equipment is provided to open the circuit if the current reaches a value that will cause an excessive or dangerous temperature in conductors or conductor insulation. See also Sections 110-9 and 110-10 for requirements for interrupting capacity and protection against fault currents.

### A. General

**240-2. Protection of Equipment.** Equipment shall be protected against overcurrent in accordance with the article in this Code covering the type of equipment as specified in the following list.

	<b>Article</b>
Air-Conditioning and Refrigerating Equipment .....	440
Appliances .....	422
Branch Circuits .....	210
Capacitors .....	460
Class 1, Class 2, and Class 3 Remote Control, Signaling, and Power-Limited Circuits .....	725
Closed-Loop and Programmed Power Distribution Systems .....	780
Cranes and Hoists .....	610
Electric Signs and Outline Lighting .....	600
Electric Welders .....	630
Electrolytic Cells .....	668
Elevators, Dumbwaiters, Escalators, and Moving Walks .....	620
Emergency Systems .....	700
Fire Protective Signaling Systems .....	760
Fixed Electric Heating Equipment for Pipelines and Vessels .....	427
Fixed Electric Space Heating Equipment .....	424

Fixed Outdoor Electric De-icing and Snow-Melting Equipment .....	426
Generators .....	445
Induction and Dielectric Heating Equipment .....	665
Industrial Machinery .....	670
Motion Picture and Television Studios and Similar Locations ..	530
Motors, Motor Circuits, and Controllers .....	430
Organs .....	650
Over 600 Volts, Nominal — General .....	710
Places of Assembly .....	518
Services .....	230
Solar Photovoltaic Systems .....	690
Sound-Recording and Similar Equipment .....	640
Switchboards and Panelboards .....	384
Theaters and Similar Locations .....	520
Transformers and Transformer Vaults .....	450
X-ray Equipment .....	517
	660

**240-3. Protection of Conductors — Other than Flexible Cords and Fixture Wires.** Conductors, other than flexible cords and fixture wires, shall be protected against overcurrent in accordance with their ampacities as specified in Tables 310-16 through 310-31 and all applicable notes to these tables.

*Exception No. 1: Next Higher Overcurrent Protective Device Rating.* Where the ampacity of the conductor does not correspond with the standard ampere rating of a fuse or a circuit breaker without overload trip adjustment above its rating (but which may have other trip or rating adjustments), the next higher standard device rating shall be permitted only if this rating does not exceed 800 amperes and the conductor is not part of a multioutlet branch circuit supplying receptacles for cord- and plug-connected portable loads.

Where the rating exceeds 800 amperes, a lower than standard rated and listed fuse or a circuit breaker without overload trip adjustment above its rating shall be permitted.

*Exception No. 2: Tap Conductors.* Tap conductors as permitted in Sections 210-19(c); 240-21, Exceptions No. 2, 3, 5, 8, 9 and 10; 364-10 and 364-11; and Part D of Article 430.

*Exception No. 3: Motor and Motor-Control Circuits.* Motor and motor-control circuit conductors protected in accordance with Parts C, D, E, and F of Article 430. Motor-operated appliance circuit conductors protected in accordance with Parts B and D of Article 422. Air-conditioning and refrigerating equipment circuit conductors protected in accordance with Parts C and F of Article 440.

*Exception No. 4: Remote Control Circuits.* Remote-control circuits shall comply with Article 725.

*Exception No. 5: Transformer Secondary Conductors.* Conductors supplied by the secondary side of a single-phase transformer having a 2-wire (single-voltage) secondary shall be considered as protected by overcurrent protection provided on the primary (supply) side of the transformer, provided this protection is in accordance with Section 450-3 and does not exceed the value determined by multiplying the secondary conductor ampacity by the

*secondary-to-primary transformer voltage ratio. Transformer secondary conductors (other than 2 wire) are not considered to be protected by the primary overcurrent protection.*

*Exception No. 6: Capacitor circuits which comply with Article 460.*

*Exception No. 7: Welders circuits which comply with Article 630.*

*Exception No. 8: Power Loss Hazard. Conductor overload protection shall not be required where the interruption of the circuit would create a hazard, such as in a material handling magnet circuit. Short-circuit protection shall be provided.*

**240-4. Protection of Fixture Wires and Cords.** Flexible cord, including tinsel cord and extension cords, shall be protected against overcurrent in accordance with their ampacities as specified in Table 400-5. Fixture wire shall be protected against overcurrent in accordance with its ampacity as specified in Table 402-5. Supplementary overcurrent protection as in Section 240-10 shall be permitted to be an acceptable means for providing this protection.

*Exception No. 1: When a flexible cord or a tinsel cord approved for and used with a specific listed appliance or portable lamps is connected to a branch circuit of Article 210 in accordance with the following:*

*20-ampere circuits, tinsel cord or No. 18 cord and larger.*

*30-ampere circuits, No. 16 cord and larger.*

*40-ampere circuits, cord of 20-ampere capacity and over.*

*50-ampere circuits, cord of 20-ampere capacity and over.*

*Exception No. 2: When fixture wire is connected to 120-volt or higher branch circuit of Article 210 in accordance with the following:*

*20-ampere circuits, No. 18 up to 50 feet (15.2 m) of run length.*

*20-ampere circuits, No. 16 up to 100 feet (30.5 m) of run length.*

*20-ampere circuits, No. 14 and larger.*

*30-ampere circuits, No. 14 and larger.*

*40-ampere circuits, No. 12 and larger.*

*50-ampere circuits, No. 12 and larger.*

*Exception No. 3: Flexible cord used in listed extension cord sets having No. 16 AWG or larger conductors shall be considered to be protected by 20-ampere branch-circuit overcurrent protection.*

**240-6. Standard Ampere Ratings.** The standard ampere ratings for fuses and inverse time circuit breakers shall be considered 15, 20, 25, 30, 35, 40, 45, 50, 60, 70, 80, 90, 100, 110, 125, 150, 175, 200, 225, 250, 300, 350, 400, 450, 500, 600, 700, 800, 1000, 1200, 1600, 2000, 2500, 3000, 4000, 5000, and 6000.

*Exception: Additional standard ratings for fuses shall be considered 1, 3, 6, 10, and 601.*

For the purposes of this article, the rating of an adjustable trip circuit breaker having readily accessible external means for adjusting the trip setting shall be the maximum permissible rating or setting.

**240-8. Fuses or Circuit Breakers in Parallel.** Fuses, circuit breakers, or combinations thereof shall not be connected in parallel.

*Exception: Circuit breakers or fuses, factory assembled in parallel, and approved as a unit.*

**240-9. Thermal Devices.** Thermal cutouts, thermal relays, and other devices not designed to open short circuits shall not be used for the protection of conductors against overcurrent due to short circuits or grounds but the use of such devices shall be permitted to protect motor-branch-circuit conductors from overload if protected in accordance with Section 430-40.

**240-10. Supplementary Overcurrent Protection.** Where supplementary overcurrent protection is used for lighting fixtures, appliances, and other equipment or for internal circuits and components of equipment, it shall not be used as a substitute for branch-circuit overcurrent devices or in place of the branch-circuit protection specified in Article 210. Supplementary overcurrent devices shall not be required to be readily accessible.

**240-11. Definition of Current-Limiting Overcurrent Protective Device.** A current-limiting overcurrent protective device is a device which, when interrupting currents in its current-limiting range, will reduce the current flowing in the faulted circuit to a magnitude substantially less than that obtainable in the same circuit if the device were replaced with a solid conductor having comparable impedance.

**240-12. Electrical System Coordination.** Where an orderly shutdown is required to minimize hazard(s) to personnel and equipment, a system of coordination based on the following two conditions shall be permitted:

(1) Coordinated short-circuit protection.

(2) Overload indication based on monitoring systems or devices.

(FPN): Coordination is defined as properly localizing a fault condition to restrict outages to the equipment affected, accomplished by choice of selective fault-protective devices. The monitoring system may cause the condition to go to alarm allowing corrective action or an orderly shutdown thereby minimizing personnel hazard and equipment damage.

## B. Location

**240-20. Ungrounded Conductors.**

(a) **Overcurrent Device Required.** A fuse or an overcurrent trip unit of a circuit breaker shall be connected in series with each ungrounded conductor. A combination of a current transformer and overcurrent relay shall be considered equivalent to an overcurrent trip unit.

(FPN): For motor circuits, see Parts C, D, F, and J of Article 430.

(b) **Circuit Breaker as Overcurrent Device.** Circuit breakers shall open all ungrounded conductors of the circuit.

*Exception: Individual single-pole circuit breakers shall be acceptable as the protection for each ungrounded conductor of 3-wire direct-current or single-phase circuits, or for each ungrounded conductor of lighting or appliance branch circuits connected to 4-wire, 3-phase systems or 5-wire, 2-phase systems, provided such lighting or appliance circuits are supplied from a system having a grounded neutral and no conductor in such circuits operates at a voltage greater than permitted in Section 210-6.*

**(c) Closed-Loop Power Distribution Systems.** Listed devices providing equivalent overcurrent protection in closed-loop power distribution systems shall be permitted as a substitute for fuses or circuit breakers.

**240-21. Location in Circuit.** An overcurrent device shall be connected at the point where the conductor to be protected receives its supply.

*Exception No. 1: Smaller Conductor Protected.* Where the overcurrent device protecting the larger conductor also protects the smaller conductor in accordance with Tables 310-16 through 310-31.

*Exception No. 2: Feeder Taps Not Over 10 Feet (3.05 m) Long.* For conductors tapped to a feeder or transformer secondary where all the following conditions are met:

a. The length of the tap conductors does not exceed 10 feet (3.05 m).

b. The ampacity of the tap conductors is:

(1) not less than the combined computed loads on the circuits supplied by the tap conductors, and

(2a) not less than the rating of the device supplied by the tap conductors, or

(2b) not less than the rating of the overcurrent protective device at the termination of the tap conductors.

c. The tap conductors do not extend beyond the switchboard, panelboard, or control devices they supply.

d. Except at the point of connection to the feeder, the tap conductors are enclosed in a raceway, which shall extend from the tap to the enclosure of an enclosed switchboard, panelboard, or control devices, or to the back of an open switchboard.

(FPN): See Section 384-16(a) for lighting and appliance branch-circuit panelboards.

*Exception No. 3: Feeder Taps Not Over 25 Feet (7.62 m) Long.* For conductors tapped to a feeder where all of the following conditions are met:

a. The length of the tap conductors does not exceed 25 feet (7.62 m).

b. The ampacity of the tap conductors is not less than  $\frac{1}{3}$  that of the feeder conductors or overcurrent protection from which they are tapped.

c. The tap conductors terminate with a single circuit breaker or a single set of fuses that will limit the load to the ampacity of the tap conductors. This single overcurrent device shall be permitted to supply any number of additional overcurrent devices on its load side.

d. The tap conductors are suitably protected from physical damage and are enclosed in a raceway.

*Exception No. 4: Service Conductors.* For service-entrance conductors where protected in accordance with Section 230-91.

*Exception No. 5: Branch-Circuit Taps.* Taps to individual outlets and circuit conductors supplying a single household electric range shall be considered as protected by the branch-circuit overcurrent devices when in accordance with the requirements of Sections 210-19, 210-20, and 210-24.

*Exception No. 6: Motor Circuit Taps.* For motor-branch-circuit conductors where protected in accordance with Sections 430-28 and 430-53.

*Exception No. 7: Busway Taps. For busways where protected in accordance with Sections 364-10 through 364-14.*

*Exception No. 8: Transformer Feeder Taps with Primary Plus Secondary Not Over 25 Feet (7.62 m) Long: Where all of the following conditions are met:*

*a. The conductors supplying the primary of a transformer have an ampacity at least  $\frac{1}{3}$  that of the conductors or overcurrent protection from which they are tapped.*

*b. The conductors supplied by the secondary of the transformer have an ampacity that, when multiplied by the ratio of the secondary-to-primary voltage, is at least  $\frac{1}{3}$  the ampacity of the conductors or overcurrent protection from which the primary conductors are tapped.*

*c. The total length of one primary plus one secondary conductor, excluding any portion of the primary conductor that is protected at its ampacity, is not over 25 feet (7.62 m).*

*d. The primary and secondary conductors are suitably protected from physical damage.*

*e. The secondary conductors terminate in a single circuit breaker or set of fuses which will limit the load to that allowed in Tables 310-16 through 310-31.*

*Exception No. 9: Conductors from generator terminals to the first overcurrent device as covered in Section 445-5.*

*Exception No. 10: Feeder Taps Over 25 Feet (7.62 m) Long. In high bay manufacturing buildings over 35 feet (10.67 m) high at walls, where conditions of maintenance and supervision assure that only qualified persons will service the systems, conductors tapped to a feeder shall be permitted to be not over 25 feet (7.62 m) long horizontally and not over 100 feet (30.5 m) total length where all of the following conditions are met.*

*a. The ampacity of the tap conductors is not less than  $\frac{1}{3}$  that of the overcurrent device from which they are supplied.*

*b. The tap conductors terminate with a single circuit breaker or a single set of fuses that will limit the load to the ampacity of the tap conductors. This single overcurrent device shall be permitted to supply any number of additional overcurrent devices on its load side.*

*c. The tap conductors are suitably protected from physical damage and are installed in raceways.*

*d. The tap conductors are continuous from end-to-end and contain no splices.*

*e. The tap conductors shall be No. 6 AWG copper or No. 4 AWG aluminum or larger.*

*f. The tap conductors shall not penetrate walls, floors, or ceilings.*

*g. The tap shall be made no less than 30 feet (9.14 m) from the floor.*

*Exception No. 11: Transformer Secondary Conductors of Separately Derived Systems for Industrial Installations. For conductors connected to a transformer secondary of a separately derived system where all of the following conditions are met:*

*a. The length of the secondary conductors does not exceed 25 feet (7.62 m).*



*b. The ampacity of the conductors is not less than the secondary current rating of the transformer and the sum of the overcurrent devices will limit the load to this capacity.*

*c. All overcurrent devices are grouped.*

*d. The tap conductors are suitably protected from physical damage.*

**240-22. Grounded Conductors.** No overcurrent device shall be connected in series with any conductor that is intentionally grounded.

*Exception No. 1: Where the overcurrent device opens all conductors of the circuit, including the grounded conductor, and is so designed that no pole can operate independently.*

*Exception No. 2: Where required by Sections 430-36 and 430-37 for motor overload protection.*

**240-23. Change in Size of Grounded Conductor.** Where a change occurs in the size of the ungrounded conductor, a similar change shall be permitted to be made in the size of the grounded conductor.

**240-24. Location in or on Premises.**

**(a) Readily Accessible.** Overcurrent devices shall be readily accessible.

*Exception No. 1: For busways as provided in Section 364-12.*

*Exception No. 2: For supplementary overcurrent protection as described in Section 240-10.*

*Exception No. 3: For service overcurrent devices as described in Section 230-92.*

**(b) Occupant to Have Ready Access.** Each occupant shall have ready access to all overcurrent devices protecting the conductors supplying that occupancy.

*Exception: In a multiple-occupancy building where electric service and electrical maintenance are provided by the building management and where these are under continuous building management supervision, the service overcurrent devices and feeder overcurrent devices supplying more than one occupancy shall be permitted to be accessible to authorized management personnel only.*

**(c) Not Exposed to Physical Damage.** Overcurrent devices shall be located where they will not be exposed to physical damage.

**(d) Not in Vicinity of Easily Ignitable Material.** Overcurrent devices shall not be located in the vicinity of easily ignitable material such as in clothes closets.

### C. Enclosures

**240-30. General.** Overcurrent devices shall be enclosed in cabinets or cutout boxes.

*Exception No. 1: Where a part of an assembly that provides equivalent protection.*

*Exception No. 2: Where mounted on open-type switchboards, panelboards, or control boards that are in rooms or enclosures free from dampness and easily ignitable material and accessible only to qualified personnel.*

*Exception No. 3: The operating handle of a circuit breaker shall be permitted to be accessible without opening a door or cover.*

**240-32. Damp or Wet Locations.** Enclosures for overcurrent devices in damp or wet locations shall be identified for use in such locations and shall be mounted so there is at least  $\frac{1}{4}$ -inch (6.35-mm) air space between the enclosure and the wall or other supporting surface.

**240-33. Vertical Position.** Enclosures for overcurrent devices shall be mounted in a vertical position.

*Exception: Where this is shown to be impracticable and complies with Section 240-81.*

#### D. Disconnecting and Guarding

**240-40. Disconnecting Means for Fuses and Thermal Cutouts.** Disconnecting means shall be provided on the supply side of all fuses or thermal cutouts in circuits of over 150 volts to ground and cartridge fuses in circuits of any voltage, where accessible to other than qualified persons, so that each individual circuit containing fuses or thermal cutouts can be independently disconnected from the source of electric energy.

*Exception No. 1: A device provided for current limiting on the supply side of the service disconnecting means as permitted by Section 230-82.*

*Exception No. 2: A single disconnecting means shall be permitted on the supply side of more than one set of fuses as provided by Section 430-112 for group operation of motors and in Section 424-22 for fixed electric space heating equipment.*

**240-41. Arcing or Suddenly Moving Parts.** Arcing or suddenly moving parts shall comply with (a) and (b) below.

(a) **Location.** Fuses and circuit breakers shall be so located or shielded that persons will not be burned or otherwise injured by their operation.

(b) **Suddenly Moving Parts.** Handles or levers of circuit breakers, and similar parts which may move suddenly in such a way that persons in the vicinity are likely to be injured by being struck by them, shall be guarded or isolated.

#### E. Plug Fuses, Fuseholders, and Adapters

**240-50. General.**

(a) **Maximum Voltage.** Plug fuses and fuseholders shall not be used in circuits exceeding 125 volts between conductors.

*Exception: In circuits supplied by a system having a grounded neutral and having no conductor at over 150 volts to ground.*

(b) **Marking.** Each fuse, fuseholder, and adapter shall be marked with its ampere rating.

(c) **Hexagonal Configuration.** Plug fuses of 15-ampere and lower rating shall be identified by a hexagonal configuration of the window, cap, or other prominent part to distinguish them from fuses of higher ampere ratings.

(d) **No Live Parts.** Plug fuses, fuseholders, and adapters shall have no exposed live parts after fuses or fuses and adapters have been installed.

(e) **Screw Shell.** The screw shell of a plug-type fuseholder shall be connected to the load side of the circuit.

#### **240-51. Edison-Base Fuses.**

(a) **Classification.** Plug fuses of the Edison-base type shall be classified at not over 125 volts and 30 amperes and below.

(b) **Replacement Only.** Plug fuses of the Edison-base type shall be used only for replacements in existing installations where there is no evidence of overfusing or tampering.

**240-52. Edison-Base Fuseholders.** Fuseholders of the Edison-base type shall be installed only where they are made to accept Type S fuses by the use of adapters.

**240-53. Type S Fuses.** Type S fuses shall be of the plug type and shall comply with (a) and (b) below.

(a) **Classification.** Type S fuses shall be classified at not over 125 volts and 0 to 15 amperes, 16 to 20 amperes, and 21 to 30 amperes.

(b) **Noninterchangeable.** Type S fuses of an ampere classification as specified in (a) above shall not be interchangeable with a lower ampere classification. They shall be so designed that they cannot be used in any fuseholder other than a Type S fuseholder or a fuseholder with a Type S adapter inserted.

#### **240-54. Type S Fuses, Adapters, and Fuseholders.**

(a) **To Fit Edison-Base Fuseholders.** Type S adapters shall fit Edison-base fuseholders.

(b) **To Fit Type S Fuses Only.** Type S fuseholders and adapters shall be so designed that either the fuseholder itself or the fuseholder with a Type S adapter inserted cannot be used for any fuse other than a Type S fuse.

(c) **Nonremovable.** Type S adapters shall be so designed that once inserted in a fuseholder, they cannot be removed.

(d) **Nontamperable.** Type S fuses, fuseholders, and adapters shall be so designed that tampering or shunting (bridging) would be difficult.

(e) **Interchangeability.** Dimensions of Type S fuses, fuseholders, and adapters shall be standardized to permit interchangeability regardless of the manufacturer.

### **F. Cartridge Fuses and Fuseholders**

#### **240-60. General.**

(a) **Maximum Voltage — 300-Volt Type.** Cartridge fuses and fuseholders of the 300-volt type shall not be used in circuits of over 300 volts between conductors.

*Exception: In circuits supplied by a system having a grounded neutral and having no conductor at over 300 volts to ground.*

(b) **Noninterchangeable — 0-6000 Ampere Cartridge Fuseholders.** Fuseholders shall be so designed that it will be difficult to put a fuse of any given class into a fuseholder that is designed for a current lower, or voltage higher, than that of the class to which it belongs. Fuseholders for current-limiting fuses shall not permit insertion of fuses that are not current limiting.

(c) **Marking.** Fuses shall be plainly marked, either by printing on the fuse barrel or by a label attached to the barrel, showing the following: (1) ampere rating; (2) voltage rating; (3) interrupting rating where other than 10,000 amperes; (4) "current limiting" where applicable; (5) the name or trademark of the manufacturer.

*Exception: Interrupting rating marking shall not be required on fuses used for supplementary protection.*

**240-61. Classification.** Cartridge fuses and fuseholders shall be classified according to voltage and amperage ranges. Fuses rated 600 volts, nominal, or less, shall be permitted to be used for voltages at or below their ratings.

### G. Circuit Breakers

**240-80. Method of Operation.** Circuit breakers shall be trip free and capable of being closed and opened by manual operation. Their normal method of operation by other than manual means such as electrical or pneumatic shall be permitted if means for manual operation is also provided.

*Exception: As provided in Section 230-76(2) for circuit breakers used as service disconnecting means.*

**240-81. Indicating.** Circuit breakers shall clearly indicate whether they are in the open "off" or closed "on" position.

Where circuit breaker handles on switchboards or in panelboards are operated vertically rather than rotationally or horizontally, the "up" position of the handle shall be the "on" position.

**240-82. Nontamperable.** A circuit breaker shall be of such design that any alteration of its trip point (calibration) or the time required for its operation will require dismantling of the device or breaking of a seal for other than intended adjustments.

#### **240-83. Marking.**

(a) **Durable and Visible.** Circuit breakers shall be marked with their ampere rating in a manner that will be durable and visible after installation. Such marking shall be permitted to be made visible by removal of a trim or cover.

(b) **Location:** Circuit breakers rated at 100 amperes or less and 600 volts or less shall have the ampere rating molded, stamped, etched, or similarly marked into their handles or escutcheon areas.

(c) **Interrupting Rating.** Every circuit breaker having an interrupting rating other than 5000 amperes shall have its interrupting rating shown on the circuit breaker.

*Exception: Interrupting rating marking shall not be required on circuit breakers used for supplementary protection.*

(d) **Circuit Breakers Used as Switches.** Where used as switches in 120-volt and 277-volt fluorescent lighting circuits, circuit breakers shall be approved for such switching duty and shall be marked "SWD."

## H. Overcurrent Protection Over 600 Volts, Nominal

**240-100. Feeders.** Feeders shall have a short-circuit protective device in each ungrounded conductor or comply with Section 230-208(d)(2) or (d)(3). The protective device(s) shall be capable of detecting and interrupting all values of current which can occur at their location in excess of their trip setting or melting point. In no case shall the fuse rating in continuous amperes exceed three times, or the long-time trip element setting of a breaker six times, the ampacity of the conductor.

Conductors tapped to a feeder shall be permitted to be protected by the feeder overcurrent device where that overcurrent device also protects the tap conductors.

(FPN): The operating time of the protective device, the available short-circuit current, and the conductor used will need to be coordinated to prevent damaging or dangerous temperatures in conductors or conductor insulation under short-circuit conditions.

**240-101. Branch Circuits.** Branch circuits shall have a short-circuit protective device in each ungrounded conductor or comply with Section 230-208 (d)(2) or (d)(3). The protective device(s) shall be capable of detecting and interrupting all values of current which can occur at their location in excess of their trip setting or melting point.

## ARTICLE 250 — GROUNDING

### A. General

**250-1. Scope.** This article covers general requirements for grounding and bonding of electrical installations, and specific requirements in (a) through (f) below.

(a) Systems, circuits, and equipment required, permitted, or not permitted to be grounded.

(b) Circuit conductor to be grounded on grounded systems.

(c) Location of grounding connections.

(d) Types and sizes of grounding and bonding conductors and electrodes.

(e) Methods of grounding and bonding.

(f) Conditions under which guards, isolation, or insulation may be substituted for grounding.

(FPN): Systems and circuit conductors are grounded to limit voltages due to lightning, line surges; or unintentional contact with higher voltage lines, and to stabilize the voltage to ground during normal operation. Systems and circuit conductors are solidly grounded to facilitate overcurrent device operation in case of ground faults.

(FPN): Conductive materials enclosing electrical conductors or equipment, or forming part of such equipment, are grounded to limit the voltage to ground on these materials and to facilitate overcurrent device operation in case of ground faults. See Section 110-10.

**250-2. Application of Other Articles.** In other articles applying to particular cases of installation of conductors and equipment, there are requirements that are in addition to those of this article or are modifications of them:

	<b>Article</b>	<b>Section</b>
Agricultural Buildings .....		547-8
Appliances .....		422-16
Branch Circuits .....		210-5
		210-6
		210-7
Cablebus .....		365-9
Circuits and Equipment Operating at Less Than 50 Volts .....	720	
Class 1, Class 2, and Class 3 Circuits .....		725-20
		725-43
Closed-Loop and Programmed Power Distribution .		780-3
		780-4(a)
Communications Circuits .....	800	
Community Antenna Television and Radio Dis- tribution Systems .....		820-7
		820-22
		820-23
Conductors .....	310	
Conductors (Grounded) .....	200	
Cranes and Hoists .....	610	
Data Processing Systems .....		645-4
Electrically Driven or Controlled Irrigation Ma- chines .....		675-11(c)
		675-12
		675-13
		675-14
		675-15
Electric Signs and Outline Lighting .....	600	
Electrolytic Cells .....	668	
Elevators, Dumbwaiters, Escalators, and Moving Walks .....	620	
Fire Protective Signaling Systems .....		760-6
Fixed Electric Heating Equipment for Pipelines and Vessels .....		427-21
		427-29
		427-48
Fixed Electric Space Heating Equipment .....		424-14
Fixed Outdoor Electric De-Icing and Snow-Melt- ing Equipment .....		426-27
Fixtures and Lighting Equipment .....		410-17
		410-18
		410-19
		410-21
		410-105(b)

	Article	Section
Flexible Cords .....		400-22 400-23
Floating Buildings .....		553-8 553-10 553-11
Grounding-type Receptacles (Outlets) .....		210-7
Hazardous (Classified) Locations .....	500—517	
Health Care Facilities .....	517	
Induction and Dielectric Heating Equipment .....	665	
Industrial Machinery .....	670	
Lighting Fixtures, Lampholders, Lamp Receptacles, and Rosettes .....	410	
Marinas and Boatyards .....		555-7
Mobile Homes and Mobile Home Parks .....	550	
Motion Picture and Television Studios and Similar Locations .....		530-20 530-66
Motors, Motor Circuits, and Controllers .....	430	
Organs .....	650	
Outlet, Device, Pull and Junction Boxes, Conduit Bodies and Fittings .....		370-4 370-15
Over 600 Volts, General .....		710-3(b)(1)
Panelboards .....		384-27
Radio and Television Equipment .....	810	
Receptacles and Attachment Plugs .....		410-58
Recreational Vehicles and Recreational Vehicle Parks .....	551	
Services .....	230	
Service Equipment .....		230-63
Solar Photovoltaic Systems .....		690-41 690-42 690-43 690-44
Sound Recording and Similar Equipment .....		640-4
Swimming Pools, Fountains and Similar Installations .....	680	
Switchboards and Panelboards .....		384-3(c) 384-11
Switches .....		380-12
Theaters and Similar Locations .....		520-81
Transformers and Transformer Vaults .....		450-10
X-ray Equipment .....	660	517-151

## B. Circuit and System Grounding

### 250-3. Direct-Current Systems.

(a) **Two-Wire Direct Current Systems.** Two-wire dc systems supplying premises wiring shall be grounded.

*Exception No. 1: A system equipped with a ground detector and supplying only industrial equipment in limited areas.*

*Exception No. 2: A system operating at 50 volts or less between conductors.*

*Exception No. 3: A system operating at over 300 volts between conductors.*

*Exception No. 4: A rectifier-derived dc system supplied from an ac system complying with Section 250-5.*

*Exception No. 5: DC fire protective signaling circuits having a maximum current of 0.030 amperes as specified in Article 760, Part C.*

(b) **Three-Wire Direct-Current Systems.** The neutral conductor of all 3-wire dc systems supplying premises wiring shall be grounded.

**250-5. Alternating-Current Circuits and Systems to Be Grounded.** AC circuits and systems shall be grounded as provided for in (a), (b), (c), or (d) below. Other circuits and systems shall be permitted to be grounded.

(a) **Alternating-Current Circuits of Less than 50 Volts.** AC circuits of less than 50 volts shall be grounded under any of the following conditions:

(1) Where supplied by transformers if the transformer supply system exceeds 150 volts to ground.

(2) Where supplied by transformers if the transformer supply system is ungrounded.

(3) Where installed as overhead conductors outside of buildings.

(b) **Alternating-Current Systems of 50 Volts to 1000 Volts.** AC systems of 50 volts to 1000 volts supplying premises wiring and premises wiring systems shall be grounded under any of the following conditions:

(1) Where the system can be so grounded that the maximum voltage to ground on the ungrounded conductors does not exceed 150 volts.

(2) Where the system is nominally rated 480Y/277-volt, 3-phase, 4-wire in which the neutral is used as a circuit conductor.

(3) Where the system is nominally rated 240/120-volt, 3-phase, 4-wire in which the midpoint of one phase is used as a circuit conductor.

(4) Where a service conductor is uninsulated in accordance with Sections 230-22, 230-30, 230-41.

*Exception No. 1: Electric systems used exclusively to supply industrial electric furnaces for melting, refining, tempering, and the like.*

*Exception No. 2: Separately derived systems used exclusively for rectifiers supplying only adjustable speed industrial drives.*

*Exception No. 3: Separately derived systems supplied by transformers that have a primary voltage rating less than 1000 volts provided that all of the following conditions are met:*

a. *The system is used exclusively for control circuits.*



*b. The conditions of maintenance and supervision assure that only qualified persons will service the installation.*

*c. Continuity of control power is required.*

*d. Ground detectors are installed on the control system.*

*Exception No. 4: Isolated systems as permitted in Article 517.*

(FPN): The proper use of suitable ground detectors on ungrounded systems can provide additional protection.

*Exception No. 5: High-impedance grounded neutral systems in which a grounding impedance, usually a resistor, limits the ground-fault current to a low value. High impedance grounded neutral systems shall be permitted for three-phase ac systems of 480 volts to 1000 volts where all of the following conditions are met:*

*a. The conditions of maintenance and supervision assure that only qualified persons will service the installation.*

*b. Continuity of power is required.*

*c. Ground detectors are installed on the system.*

*d. Line-to-neutral loads are not served.*

**(c) Alternating-Current Systems of 1 kV and Over.** AC systems of 1 kV and over supplying mobile or portable equipment shall be grounded as specified in Section 250-154. Where supplying other than portable equipment, such systems shall be permitted to be grounded. Where such systems are grounded, they shall comply with the applicable provisions of this article.

**(d) Separately Derived Systems.** A premises wiring system whose power is derived from generator, transformer, or converter windings and has no direct electrical connection, including a solidly connected grounded circuit conductor, to supply conductors originating in another system, if required to be grounded as in (a) or (b) above, shall be grounded as specified in Section 250-26.

(FPN): An alternate alternating-current power source such as an on-site generator is not a separately derived system if the neutral is solidly interconnected to a service-supplied system neutral.

(FPN): For systems that are not separately derived and are not required to be grounded as specified in Section 250-26, see Section 445-5 for minimum size of conductors which must carry fault current.

## **250-6. Portable and Vehicle-Mounted Generators.**

**(a) Portable Generators.** Under the following conditions the frame of a portable generator shall not be required to be grounded and shall be permitted to serve as the grounding electrode for a system supplied by the generator:

(1) The generator supplies only equipment mounted on the generator and/or cord- and plug-connected equipment through receptacles mounted on the generator, and

(2) The noncurrent-carrying metal parts of equipment and the equipment grounding conductor terminals of the receptacles are bonded to the generator frame.

**(b) Vehicle-Mounted Generators.** Under the following conditions the frame of a vehicle shall be permitted to serve as the grounding electrode for a system supplied by a generator located on the vehicle:

- (1) The frame of the generator is bonded to the vehicle frame, and
- (2) The generator supplies only equipment located on the vehicle and/or cord- and plug-connected equipment through receptacles mounted on the vehicle or on the generator, and
- (3) The noncurrent-carrying metal parts of equipment and the equipment grounding conductor terminals of the receptacles are bonded to the generator frame, and
- (4) The system complies with all other provisions of this article.

(c) **Neutral Conductor Bonding.** A neutral conductor shall be bonded to the generator frame when the generator is a component of a separately derived system. The bonding of any conductor other than a neutral within the generator to its frame shall not be required.

(FPN): For grounding of portable generators supplying fixed wiring systems, see Section 250-5(d).

**250-7. Circuits Not to Be Grounded.** The following circuits shall not be grounded:

- (a) **Cranes.** Circuits for electric cranes operating over combustible fibers in Class III locations, as provided in Section 503-13.
- (b) **Health Care Facilities.** Circuits as provided in Article 517.

### C. Location of System Grounding Connections

**250-21. Objectionable Current over Grounding Conductors.**

(a) **Arrangement to Prevent Objectionable Current.** The grounding of electric systems, circuit conductors, surge arresters, and conductive noncurrent-carrying materials and equipment shall be installed and arranged in a manner that will prevent an objectionable flow of current over the grounding conductors or grounding paths.

(b) **Alterations to Stop Objectionable Current.** If the use of multiple grounding connections results in an objectionable flow of current, one or more of the following alterations shall be made:

- (1) Discontinue one or more such grounding connections.
- (2) Change the locations of the grounding connections.
- (3) Interrupt the continuity of the conductor or conductive path interconnecting the grounding connections.
- (4) Take other suitable remedial action satisfactory to the authority having jurisdiction.

(c) **Temporary Currents Not Classified as Objectionable Currents.** Temporary currents resulting from accidental conditions, such as ground-fault currents, that occur only while the grounding conductors are performing their intended protective functions shall not be classified as objectionable current for the purposes specified in (a) and (b) above.

**250-22. Point of Connection for Direct-Current Systems.** DC systems to be grounded shall have the grounding connection made at one or more supply stations. A grounding connection shall not be made at individual services nor at any point on premises wiring.

*Exception: Where the dc system source is located on the premises a grounding connection shall be made at the source or the first system disconnecting means or overcurrent device.*

### **250-23. Grounding Service-Supplied Alternating-Current Systems.**

**(a) System Grounding Connections.** A premises wiring system that is supplied by an ac service and is required to be grounded by Section 250-5 shall have at each service a grounding electrode conductor connected to a grounding electrode which complies with Part H of Article 250. The grounding electrode conductor shall be connected to the grounded service conductor at any accessible point from the load end of the service drop or service lateral to and including the terminal or bus to which the grounded service conductor is connected at the service disconnecting means. Where the transformer supplying the service is located outside the building, at least one additional grounding connection shall be made from the grounded service conductor to a grounding electrode, either at the transformer or elsewhere outside the building. A grounding connection shall not be made to any grounded circuit conductor on the load side of the service disconnecting means.

(FPN): See definition of Service Drop and Service Lateral; also Section 230-21.

*Exception No. 1: A grounding electrode conductor shall be connected to the grounded conductor of a separately derived system in accordance with the provisions of Section 250-26(b).*

*Exception No. 2: A grounding conductor connection shall be made at each separate building where required by Section 250-24.*

*Exception No. 3: For ranges, counter-mounted cooking units, wall-mounted ovens, clothes dryers, and meter enclosures as permitted by Section 250-61.*

*Exception No. 4: For services that are dual fed (double ended) in a common enclosure or grouped together in separate enclosures and employing a secondary tie, a single grounding electrode connection to the tie point of the grounded circuit conductors from each power source shall be permitted.*

*Exception No. 5: Where the main bonding jumper specified in Sections 250-53(b) and 250-79 is a wire or busbar, and is installed from the neutral bar or bus to the equipment grounding terminal bar or bus in the service equipment, the grounding electrode conductor shall be permitted to be connected to the equipment grounding terminal bar or bus to which the main bonding jumper is connected.*

*Exception No. 6: As covered in Section 250-27 for high-impedance grounded neutral systems grounding connection requirements.*

**(b) Grounded Conductor Brought to Service Equipment.** Where an ac system operating at less than 1000 volts is grounded at any point, the grounded conductor shall be run to each service. This conductor shall be routed with the phase conductors and shall not be smaller than the required grounding electrode conductor specified in Table 250-94 and, in addition, for service phase conductors larger than 1100 MCM copper or 1750 MCM aluminum, the grounded conductor shall not be smaller than 12 1/2 percent of the area of the largest phase conductor. Where the service phase conductors

are paralleled, the size of the grounded conductor shall be based on the equivalent area for parallel conductors as indicated in this section.

*Exception No. 1: The grounded conductor shall not be required to be larger than the largest ungrounded service conductor or equivalent area for paralleled conductors.*

*Exception No. 2: As covered in Section 250-27 for high-impedance grounded neutral systems grounding connection requirements.*

#### **250-24. Two or More Buildings or Structures Supplied from a Common Service.**

**(a) Grounded Systems.** Where two or more buildings or structures are supplied from a common service, the grounded system in each building or structure shall have a grounding electrode as described in Part H connected to the metal enclosure of the building disconnecting means and to the ac system grounded circuit conductor on the supply side of the building or structure disconnecting means.

*Exception No. 1: A grounding electrode at separate buildings or structures shall not be required where only one branch circuit is supplied and there is no equipment in the building or structure that requires grounding.*

*Exception No. 2: A grounded circuit conductor connection to the grounding electrode shall not be required at a separate building or structure if an equipment grounding conductor is run with the circuit conductors for grounding any noncurrent-carrying equipment, interior metal piping systems and building or structural metal frames and the equipment grounding conductor is bonded at a separate building or structure disconnecting means to existing grounding electrodes described in Part H. Where there are no existing electrodes, a grounding electrode meeting the requirements of Part H shall be installed where the building or structure supplies more than one branch circuit. Where livestock is housed, that portion of the equipment grounding conductor run underground to the disconnecting means shall be insulated or covered copper.*

**(b) Ungrounded Systems.** Where two or more buildings or structures are supplied by a common service from an ungrounded system, each building or structure shall have a grounding electrode as described in Part H connected to the metal enclosure of the building or structure disconnecting means.

*Exception No. 1: A grounding electrode at separate buildings or structures shall not be required where only one branch circuit is supplied and there is no equipment in the building or structure that requires grounding.*

*Exception No. 2: A grounding electrode and grounding electrode conductor connection to the metal enclosure of the building or structure disconnecting means shall not be required provided all of the following conditions are met.*

*a. An equipment grounding conductor is run with the circuit conductors to the building or structure disconnecting means for grounding any noncurrent-carrying equipment, interior metal piping systems, and building or structural metal frames.*

*b. There are no existing grounding electrodes as described in Part H.*

*c. The building or structure supplies only one branch circuit.*

*d. Where livestock is housed, that portion of the equipment grounding conductor run underground to the disconnecting means shall be insulated or covered copper.*

**250-25. Conductor to Be Grounded — Alternating-Current Systems.** For ac premises wiring systems, the conductor to be grounded shall be as specified in (1) through (5) below.

(1) Single-phase, 2-wire: one conductor.

(2) Single-phase, 3-wire: the neutral conductor.

(3) Multiphase systems having one wire common to all phases: the common conductor.

(4) Multiphase systems requiring one grounded phase: one phase conductor.

(5) Multiphase systems in which one phase is used as in (2) above: the neutral conductor.

Grounded conductors shall be identified by the means specified in Article 200.

**250-26. Grounding Separately Derived Alternating-Current Systems.** A separately derived ac system that is required to be grounded by Section 250-5 shall be grounded as specified in (a) through (d) below.

(a) **Bonding Jumper.** A bonding jumper, sized in accordance with Section 250-79(c) for the derived phase conductors, shall be used to connect the equipment grounding conductors of the derived system to the grounded conductor. Except as permitted by Exception No. 4 of Section 250-23(a), this connection shall be made at any point on the separately derived system from the source to the first system disconnecting means or overcurrent device; or it shall be made at the source of a separately derived system which has no disconnecting means or overcurrent devices.

*Exception: The size of the bonding jumper for a system that supplies a Class 1 circuit, and is derived from a transformer rated not more than 1000 volt-amperes, shall not be smaller than the derived phase conductors and shall not be smaller than No. 14 copper or No. 12 aluminum.*

(b) **Grounding Electrode Conductor.** A grounding electrode conductor, sized in accordance with Section 250-94 for the derived phase conductors, shall be used to connect the grounded conductor of the derived system to the grounding electrode as specified in (c) below. Except as permitted by Exception No. 4 of Section 250-23(a), this connection shall be made at any point on the separately derived system from the source to the first system disconnecting means or overcurrent device; or it shall be made at the source of a separately derived system which has no disconnecting means or overcurrent devices.

*Exception: A grounding electrode conductor shall not be required for a system that supplies a Class 1 circuit, and is derived from a transformer rated not more than 1000 volt-amperes, provided the system grounded conductor is bonded to the transformer frame or enclosure by a jumper sized in accordance with the Exception for (a), above, and the transformer frame or enclosure is grounded by one of the means specified in Section 250-57.*

(c) **Grounding Electrode.** The grounding electrode shall be as near as practicable to and preferably in the same area as the grounding conductor

connection to the system. The grounding electrode shall be: (1) the nearest available effectively grounded structural metal member of the structure; or (2) the nearest available effectively grounded metal water pipe; or (3) other electrodes as specified in Sections 250-81 and 250-83 where electrodes specified by (1) or (2) above are not available.

**(d) Grounding Methods.** In all other respects, grounding methods shall comply with requirements prescribed in other parts of this Code.

**250-27. High-Impedance Grounded Neutral System Connections.** High-impedance grounded neutral systems shall comply with the provisions of (a) through (f) below.

**(a) Grounding Impedance Location.** The grounding impedance shall be installed between the grounding electrode conductor and the system neutral. Where a neutral is not available, the grounding impedance shall be installed between the grounding electrode conductor and the neutral derived from a grounding transformer.

**(b) Neutral Conductor.** The neutral conductor from the neutral point of the transformer or generator to its connection point to the grounding impedance shall be fully insulated.

**(c) System Neutral Connection.** The system neutral conductor shall not be connected to ground except through the grounding impedance.

(FPN): The impedance is normally selected to limit the ground-fault current to a value slightly greater than or equal to the capacitive charging current of the system. This value of impedance will also limit transient overvoltages to safe values. For guidance, refer to criteria for limiting transient overvoltages in Recommended Practice for Grounding of Industrial and Commercial Power Systems, ANSI/IEEE Standard 142-1982.

**(d) Neutral Conductor Routing.** The conductor connecting the neutral point of the transformer or generator to the grounding impedance shall be permitted to be installed in a separate raceway. It shall not be required to run this conductor with the phase conductors to the first system disconnecting means or overcurrent device.

**(e) Equipment Bonding Jumper.** The equipment bonding jumper (the connection between the equipment grounding conductors and the grounding impedance) shall be an unspliced conductor run from the first system disconnecting means or overcurrent device to the grounded side of the grounding impedance.

**(f) Grounding Electrode Conductor Location.** The grounding electrode conductor shall be attached at any point from the grounded side of the grounding impedance to the equipment grounding connection at the service equipment or first system disconnecting means.

#### D. Enclosure Grounding

**250-32. Service Raceways and Enclosures.** Metal enclosures for service conductors and equipment shall be grounded.

**250-33. Other Conductor Enclosures.** Metal enclosures for other than service conductors shall be grounded.

*Exception No. 1: Metal enclosures for conductors added to existing installations of open wire, knob-and-tube wiring, and nonmetallic-sheathed*

*cable, which do not provide an equipment ground, if in runs of less than 25 feet (7.62 m), if free from probable contact with ground, grounded metal, metal lath, or other conductive material, and if guarded against contact by persons shall not be required to be grounded.*

*Exception No. 2: Short sections of metal enclosures used to provide support or protection of cable assemblies from physical damage shall not be required to be grounded.*

## E. Equipment Grounding

**250-42. Equipment Fastened in Place or Connected by Permanent Wiring Methods (Fixed).** Exposed noncurrent-carrying metal parts of fixed equipment likely to become energized shall be grounded under any of the conditions in (a) through (f) below.

(a) **Vertical and Horizontal Distances.** Where within 8 feet (2.44 m) vertically or 5 feet (1.52 m) horizontally of ground or grounded metal objects and subject to contact by persons.

(b) **Wet or Damp Locations.** Where located in a wet or damp location and not isolated.

(c) **Electrical Contact.** Where in electrical contact with metal.

(d) **Hazardous (Classified) Locations.** Where in a hazardous (classified) location as covered by Articles 500 through 517.

(e) **Wiring Methods.** Where supplied by a metal-clad, metal-sheathed, metal-raceway, or other wiring method which provides an equipment ground, except as permitted by Section 250-33 for short sections of metal enclosures.

(f) **Over 150 Volts to Ground.** Where equipment operates with any terminal at over 150 volts to ground.

*Exception No. 1: Enclosures for switches or circuit breakers used for other than service equipment and accessible to qualified persons only.*

*Exception No. 2: Metal frames of electrically heated appliances, exempted by special permission, in which case the frames shall be permanently and effectively insulated from ground.*

*Exception No. 3: Distribution apparatus, such as transformer and capacitor cases, mounted on wooden poles, at a height exceeding 8 feet (2.44 m) above ground or grade level.*

*Exception No. 4: Listed information processing and listed office equipment protected by a system of double insulation, or its equivalent, shall not be required to be grounded. Where such a system is employed, the equipment shall be distinctively marked.*

**250-43. Fastened in Place or Connected by Permanent Wiring Methods (Fixed) — Specific.** Exposed, noncurrent-carrying metal parts of the kinds of equipment described in (a) through (j) below, regardless of voltage, shall be grounded.

(a) **Switchboard Frames and Structures.** Switchboard frames and structures supporting switching equipment.

*Exception: Frames of two-wire dc switchboards where effectively insulated.*

(b) **Organs.** Generator and motor frames in an electrically operated organ.

*Exception: Where the generator is effectively insulated from ground and from the motor driving it.*

(c) **Motor Frames.** Motor frames, as provided by Section 430-142.

(d) **Enclosures for Motor Controllers.** Enclosures for motor controllers.

*Exception: Lined covers of snap switches.*

(e) **Elevators and Cranes.** Electric equipment for elevators and cranes.

(f) **Garages, Theaters, and Motion Picture Studios.** Electric equipment in garages, theaters, and motion picture studios.

*Exception: Pendant lampholders supplied by circuits not over 150 volts to ground.*

(g) **Electric Signs.** Electric signs and associated equipment.

*Exception: Where insulated from ground and from other conductive objects and accessible only to qualified persons.*

(h) **Motion Picture Projection Equipment.** Motion picture projection equipment.

(i) **Class 1, Class 2, and Class 3 Circuits.** Equipment supplied by Class 1, Class 2, and Class 3 remote-control and signaling circuits where required to be grounded by Part B of this article.

(j) **Lighting Fixtures.** Lighting fixtures as provided in Part E of Article 410.

**250-44. Nonelectric Equipment.** The metal parts of nonelectric equipment described in (a) through (e) below shall be grounded.

(a) **Cranes.** Frames and tracks of electrically operated cranes.

(b) **Elevator Cars.** Frames of nonelectrically driven elevator cars to which electric conductors are attached.

(c) **Electric Elevators.** Hand-operated metal shifting ropes or cables of electric elevators.

(d) **Metal Partitions.** Metal partitions, grill work, and similar metal enclosures around equipment of 1 kV and over between conductors except substations or vaults under the sole control of the supply company.

(e) **Mobile Homes and Recreational Vehicles.** Mobile homes and recreational vehicles as required in Articles 550 and 551.

(FPN): Where extensive metal in or on buildings may become energized and is subject to personal contact, adequate bonding and grounding will provide additional safety.

**250-45. Equipment Connected by Cord and Plug.** Under any of the conditions described in (a) through (d) below, exposed noncurrent-carrying metal parts of cord- and plug-connected equipment likely to become energized shall be grounded.

(a) **In Hazardous (Classified) Locations.** In hazardous (classified) locations (see Articles 500 through 517).

(b) **Over 150 Volts to Ground.** Where operated at over 150 volts to ground.

*Exception No. 1: Motors, where guarded.*



*Exception No. 2: Metal frames of electrically heated appliances, exempted by special permission, in which case the frames shall be permanently and effectively insulated from ground.*

*Exception No. 3: Listed information processing and listed office equipment protected by a system of double insulation, or its equivalent, shall not be required to be grounded. Where such a system is employed, the equipment shall be distinctively marked.*

**(c) In Residential Occupancies.** In residential occupancies: (1) refrigerators, freezers, and air conditioners; (2) clothes-washing, clothes-drying, dish-washing machines, sump pumps, electrical aquarium equipment; (3) hand-held motor-operated tools; (4) motor-operated appliances of the following types: hedge clippers, lawn mowers, snow blowers, and wet scrubbers; (5) portable handlamps.

*Exception: Listed tools and listed appliances protected by a system of double insulation, or its equivalent, shall not be required to be grounded. Where such a system is employed, the equipment shall be distinctively marked.*

**(d) In Other than Residential Occupancies.** In other than residential occupancies: (1) refrigerators, freezers, and air conditioners; (2) clothes-washing, clothes-drying, dish-washing machines, electronic computer/data processing equipment, sump pumps, electrical aquarium equipment; (3) hand-held motor-operated tools; (4) motor-operated appliances of the following types: hedge clippers, lawn mowers, snow blowers, and wet scrubbers; (5) cord- and plug-connected appliances used in damp or wet locations or by persons standing on the ground or on metal floors or working inside of metal tanks or boilers; (6) tools likely to be used in wet and conductive locations; and (7) portable handlamps.

*Exception No. 1: Tools and portable handlamps likely to be used in wet and conductive locations shall not be required to be grounded where supplied through an isolating transformer with an ungrounded secondary of not over 50 volts.*

*Exception No. 2: Listed portable tools and listed appliances protected by an approved system of double insulation, or its equivalent, shall not be required to be grounded. Where such a system is employed, the equipment shall be distinctively marked.*

(FPN): With reference to (c) and (d), portable tools or appliances are not intended to be used in damp, wet or conductive locations unless they are grounded, double insulated or supplied through an isolating transformer.

**250-46. Spacing from Lightning Rods.** Metal raceways, enclosures, frames, and other noncurrent-carrying metal parts of electric equipment shall be kept at least 6 feet (1.83 m) away from lightning rod conductors, or they shall be bonded to the lightning rod conductors.

(FPN): See Sections 250-86 and 800-31(b)(5). For further information see the Lightning Protection Code, NFPA 78-1983 (ANSI), which contains detailed information on grounding lightning protection systems.

## F. Methods of Grounding

**250-50. Equipment Grounding Conductor Connections.** Equipment grounding conductor connections at the source of separately derived systems shall

be made in accordance with Section 250-26(a). Equipment grounding conductor connections at service equipment shall be made as indicated in (a) or (b) below.

**(a) For Grounded System.** The connection shall be made by bonding the equipment grounding conductor to the grounded service conductor and the grounding electrode conductor.

**(b) For Ungrounded System.** The connection shall be made by bonding the equipment grounding conductor to the grounding electrode conductor.

*Exception for (a) and (b) above: For replacement of nongrounding-type receptacles with grounding-type receptacles and for branch-circuit extensions only in existing installations that do not have an equipment grounding conductor in the branch circuit, the grounding conductor of a grounding-type receptacle outlet shall be permitted to be grounded to a water pipe which is bonded in accordance with Section 250-80(a).*

(FPN): See Section 210-7(d), Exception, for the use of a ground-fault circuit-interrupter type of receptacle.

**250-51. Effective Grounding Path.** The path to ground from circuits, equipment, and conductor enclosures shall: (1) be permanent and continuous; (2) have capacity to conduct safely any fault current likely to be imposed on it; and (3) have sufficiently low impedance to limit the voltage to ground and to facilitate the operation of the circuit protective devices in the circuit.

The earth shall not be used as the sole equipment grounding conductor.

#### **250-53. Grounding Path to Grounding Electrode at Services.**

**(a) Grounding Electrode Conductor.** A grounding electrode conductor shall be used to connect the equipment grounding conductors, the service-equipment enclosures and, where the system is grounded, the grounded service conductor to the grounding electrode.

(FPN): See Section 250-23(a).

**(b) Main Bonding Jumper.** For a grounded system, an unspliced main bonding jumper shall be used to connect the equipment grounding conductor and the service-equipment enclosure to the grounded conductor of the system within the service equipment or within the service conductor enclosure.

**250-54. Common Grounding Electrode.** Where an ac system is connected to a grounding electrode in or at a building as specified in Sections 250-23 and 250-24, the same electrode shall be used to ground conductor enclosures and equipment in or on that building. Where separate services supply a building and are required to be connected to a grounding electrode, the same grounding electrode shall be used.

Two or more grounding electrodes that are effectively bonded together shall be considered as a single grounding electrode system in this sense.

**250-55. Underground Service Cable.** Where served from a continuous underground metal-sheathed cable system, the sheath or armor of underground service cable metallically connected to the underground system, or underground service conduit containing a metal-sheathed cable bonded to the underground system, shall not be required to be grounded at the building and shall be permitted to be insulated from the interior conduit or piping.

**250-56. Short Sections of Raceway.** Isolated sections of metal raceway or cable armor, where required to be grounded, shall be grounded in accordance with Section 250-57.

**250-57. Equipment Fastened in Place or Connected by Permanent Wiring Methods (Fixed) — Grounding.** Noncurrent-carrying metal parts of equipment, raceways, and other enclosures, where required to be grounded, shall be grounded by one of the methods indicated in (a) or (b) below.

*Exception: Where equipment, raceways, and enclosures are grounded by connection to the grounded circuit conductor as permitted by Sections 250-24, 250-60, and 250-61.*

**(a) Equipment Grounding Conductor Types.** By any of the equipment grounding conductors permitted by Section 250-91(b).

**(b) With Circuit Conductors.** By an equipment grounding conductor contained within the same raceway, cable, or cord or otherwise run with the circuit conductors. Bare, covered or insulated equipment grounding conductors shall be permitted. Individually covered or insulated equipment grounding conductors shall have a continuous outer finish that is either green, or green with one or more yellow stripes.

*Exception No. 1: An insulated or covered conductor larger than No. 6 copper or aluminum shall, at the time of installation, be permitted to be permanently identified as an equipment grounding conductor at each end and at every point where the conductor is accessible. Identification shall be accomplished by one of the following:*

- a. Stripping the insulation or covering from the entire exposed length,*
- b. Coloring the exposed insulation or covering green, or*
- c. Marking the exposed insulation or covering with green colored tape or green colored adhesive labels.*

*Exception No. 2: For direct-current circuits only, the equipment grounding conductor shall be permitted to be run separately from the circuit conductors.*

*Exception No. 3: Where the conditions of maintenance and supervision assure that only qualified persons will service the installation, an insulated conductor in a multiconductor cable shall, at the time of installation, be permitted to be permanently identified as an equipment grounding conductor at each end and at every point where the conductor is accessible by one of the following means:*

- a. Stripping the insulation from the entire exposed length,*
- b. Coloring the exposed insulation green, or*
- c. Marking the exposed insulation with green tape or green colored adhesive labels.*

(FPN): See Section 250-79 for equipment bonding jumper requirements.

(FPN): See Section 400-7 for use of cords for fixed equipment.

**250-58. Equipment Considered Effectively Grounded.** Under the conditions specified in (a) and (b) below, the noncurrent-carrying metal parts of the equipment shall be considered effectively grounded.

**(a) Equipment Secured to Grounded Metal Supports.** Electric equipment secured to and in electrical contact with a metal rack or structure provided

for its support and grounded by one of the means indicated in Section 250-57. The structural metal frame of a building shall not be used as the required equipment grounding conductor for ac equipment.

(b) **Metal Car Frames.** Metal car frames supported by metal hoisting cables attached to or running over metal sheaves or drums of elevator machines which are grounded by one of the methods indicated in Section 250-57.

**250-59. Cord- and Plug-Connected Equipment.** Noncurrent-carrying metal parts of cord- and plug-connected equipment, where required to be grounded, shall be grounded by one of the methods indicated in (a), (b), or (c) below.

(a) **By Means of the Metal Enclosure.** By means of the metal enclosure of the conductors supplying such equipment if a grounding-type attachment plug with one fixed grounding contact is used for grounding the metal enclosure, and if the metal enclosure of the conductors is secured to the attachment plug and to equipment by approved connectors.

*Exception: A self-restoring grounding contact shall be permitted on grounding-type attachment plugs used on the power supply cord of portable hand-held, hand-guided, or hand-supported tools or appliances.*

(b) **By Means of a Grounding Conductor.** By means of an equipment grounding conductor run with the power supply conductors in a cable assembly or flexible cord properly terminated in grounding-type attachment plug with one fixed grounding contact. An uninsulated equipment grounding conductor shall be permitted but, if individually covered, the covering shall have a continuous outer finish that is either green or green with one or more yellow stripes.

*Exception: A self-restoring grounding contact shall be permitted on grounding-type attachment plugs used on the power supply cord of portable hand-held, hand-guided, or hand-supported tools or appliances.*

(c) **Separate Flexible Wire or Strap.** By means of a separate flexible wire or strap, insulated or bare, protected as well as practicable against physical damage, where part of equipment.

**250-60. Frames of Ranges and Clothes Dryers.** Frames of electric ranges, wall-mounted ovens, counter-mounted cooking units, clothes dryers, and outlet or junction boxes which are part of the circuit for these appliances shall be grounded in the manner specified by Section 250-57 or 250-59; or, except for mobile homes and recreational vehicles, shall be permitted to be grounded to the grounded circuit conductor if all of the conditions indicated in (a) through (d) below are met.

(a) The supply circuit is 120/240-volt, single-phase, 3-wire; or 208Y/120-volt derived from a 3-phase, 4-wire, wye-connected system.

(b) The grounded conductor is not smaller than No. 10 copper or No. 8 aluminum.

(c) The grounded conductor is insulated; or the grounded conductor is uninsulated and part of a Type SE service-entrance cable and the branch circuit originates at the service equipment.

(d) Grounding contacts of receptacles furnished as part of the equipment are bonded to the equipment.

**250-61. Use of Grounded Circuit Conductor for Grounding Equipment.**

(a) **Supply-Side Equipment.** A grounded circuit conductor shall be permitted to ground noncurrent-carrying metal parts of equipment, raceways, and other enclosures on the supply side of the service disconnecting means, and on the supply side of the main disconnecting means for separate buildings as provided in Section 250-24.

(b) **Load-Side Equipment.** A grounded circuit conductor shall not be used for grounding noncurrent-carrying metal parts of equipment on the load side of the service disconnecting means or on the load side of a separately derived system disconnecting means or the overcurrent devices for a separately derived system not having a main disconnecting means.

*Exception No. 1: The frames of ranges, wall-mounted ovens, counter-mounted cooking units, and clothes dryers under the conditions specified by Section 250-60.*

*Exception No. 2: As permitted in Section 250-24 for separate buildings.*

*Exception No. 3: It shall be permissible to ground meter enclosures by connection to the grounded circuit conductor on the load-side of the service disconnect if:*

- a. No service ground-fault protection is installed; and*
- b. All meter enclosures are located near the service disconnecting means.*

*Exception No. 4: As required in Sections 710-72(e)(1) and 710-74.*

**250-62. Multiple Circuit Connections.** Where equipment is required to be grounded, and is supplied by separate connection to more than one circuit or grounded premises wiring system, a means for grounding shall be provided for each such connection as specified in Sections 250-57 and 250-59.

## G. Bonding

**250-70. General.** Bonding shall be provided where necessary to assure electrical continuity and the capacity to conduct safely any fault current likely to be imposed.

**250-71. Service Equipment.**

(a) **Bonding of Service Equipment.** The noncurrent-carrying metal parts of equipment indicated in (1), (2) and (3) below shall be effectively bonded together.

(1) Except as permitted in Section 250-55, the service raceways, cable trays, or service cable armor or sheath.

(2) All service equipment enclosures containing service conductors, including meter fittings, boxes, or the like, interposed in the service raceway or armor.

(3) Any metallic raceway or armor enclosing a grounding electrode conductor as permitted in Section 250-92(a).

(b) **Bonding to Other Systems.** At dwellings, an accessible means external to enclosures for connecting intersystem bonding and grounding conductors shall be provided at the service by at least one of the following means:

- (1) Exposed metallic service raceways.

(2) Exposed grounding electrode conductor.

(3) Approved means for the external connection of a bonding, or grounding conductor to the service raceway or equipment.

(FPN): A No. 6 copper conductor with one end bonded to the service raceway or equipment and with 6 inches (152 mm) or more of the other end made accessible on the outside wall of the dwelling is an example of the approved means covered in (b)(3).

(FPN): See Sections 800-31 and 820-22 for bonding and grounding requirements for communication and CATV circuits.

**250-72. Method of Bonding Service Equipment.** Electrical continuity at service equipment shall be assured by one of the methods specified in (a) through (e) below.

(a) **Grounded Service Conductor.** Bonding equipment to the grounded service conductor in a manner provided in Section 250-113.

(b) **Threaded Couplings.** Threaded couplings and threaded bosses on enclosures with joints shall be made up wrenchtight where rigid metal conduit and intermediate metal conduit are involved.

(c) **Threadless Couplings and Connectors.** Threadless couplings and connectors made up tight for rigid metal conduit, intermediate metal conduit and electrical metallic tubing. Standard locknuts or bushings shall not be used for the bonding required by this section.

(d) **Bonding Jumpers.** Bonding jumpers meeting the other requirements of this article shall be used around concentric or eccentric knockouts that are punched or otherwise formed so as to impair the electrical connection to ground.

(e) **Other Devices.** Other approved devices, such as bonding-type locknuts and bushings.

**250-73. Metal Armor or Tape of Service Cable.** The metal covering of service cable having an uninsulated grounded service conductor in continuous electrical contact with its metallic armor or tape shall be considered to be grounded.

**250-74. Connecting Receptacle Grounding Terminal to Box.** An equipment bonding jumper shall be used to connect the grounding terminal of a grounding-type receptacle to a grounded box.

*Exception No. 1: Where the box is surface mounted, direct metal-to-metal contact between the device yoke and the box shall be permitted to ground the receptacle to the box. This Exception shall not apply to cover-mounted receptacles unless the box and cover combination are listed as providing satisfactory ground continuity between the box and the receptacle.*

*Exception No. 2: Contact devices or yokes designed and listed for the purpose shall be permitted in conjunction with the supporting screws to establish the grounding circuit between the device yoke and flush-type boxes.*

*Exception No. 3: Floor boxes designed for and listed as providing satisfactory ground continuity between the box and the device.*

*Exception No. 4: Where required for the reduction of electrical noise (electromagnetic interference) on the grounding circuit, a receptacle in which the grounding terminal is purposely insulated from the receptacle mounting means shall be permitted. The receptacle grounding terminal shall*

be grounded by an insulated equipment grounding conductor run with the circuit conductors. This grounding conductor shall be permitted to pass through one or more panelboards without connection to the panelboard grounding terminal as permitted in Section 384-27, Exception No. 1, so as to terminate directly at an equipment grounding conductor terminal of the applicable derived system or service.

(FPN): Use of an isolated equipment grounding conductor does not relieve the requirement for grounding the raceway system and outlet box.

**250-75. Bonding Other Enclosures.** Metal raceways, cable trays, cable armor, cable sheath, enclosures, frames, fittings, and other metal noncurrent-carrying parts that are to serve as grounding conductors with or without the use of supplementary equipment grounding conductors shall be effectively bonded where necessary to assure electrical continuity and the capacity to conduct safely any fault current likely to be imposed on them. Any nonconductive paint, enamel, or similar coating shall be removed at threads, contact points, and contact surfaces or be connected by means of fittings so designed as to make such removal unnecessary.

**250-76. Bonding for Over 250 Volts.** For circuits of over 250 volts to ground, the electrical continuity of metal raceways and cables with metal sheaths that contain any conductor other than service conductors shall be assured by one or more of the methods specified for services in Section 250-72(b) through (e).

*Exception: Where oversized, concentric, or eccentric knockouts are not encountered, the following methods shall be permitted:*

- a. Threadless couplings and connectors for cables with metal sheaths.*
- b. Two locknuts, on rigid metal conduit, or intermediate metal conduit, one inside and one outside of boxes and cabinets.*
- c. Fittings with shoulders that seat firmly against the box or cabinet, such as electrical metallic tubing connectors, flexible metallic conduit connectors and cable connectors, with one locknut on the inside of boxes and cabinets.*

**250-77. Bonding Loosely Jointed Metal Raceways.** Expansion joints and telescoping sections of raceways shall be made electrically continuous by equipment bonding jumpers or other means.

**250-78. Bonding in Hazardous (Classified) Locations.** Regardless of the voltage of the electrical system, the electrical continuity of noncurrent-carrying metal parts of equipment, raceways, and other enclosures in any hazardous (classified) location as defined in Article 500 shall be assured by any of the methods specified for services in Section 250-72(b) through (e) that are approved for the wiring method used.

**250-79. Main and Equipment Bonding Jumpers.**

(a) **Material.** Main and equipment bonding jumpers shall be of copper or other corrosion-resistant material. A main bonding jumper shall be a wire, bus, screw, or similar suitable conductor.

(b) **Attachment.** Main and equipment bonding jumpers shall be attached in the manner specified by the applicable provisions of Section 250-113 for circuits and equipment and by Section 250-115 for grounding electrodes.

(c) **Size — Equipment Bonding Jumper on Supply Side of Service and Main Bonding Jumper.** The bonding jumper shall not be smaller than the sizes given in Table 250-94 for grounding electrode conductors. Where the service-entrance phase conductors are larger than 1100 MCM copper or 1750 MCM aluminum, the bonding jumper shall have an area not less than 12 ½ percent of the area of the largest phase conductor except that where the phase conductors and the bonding jumper are of different materials (copper or aluminum), the minimum size of the bonding jumper shall be based on the assumed use of phase conductors of the same material as the bonding jumper and with an ampacity equivalent to that of the installed phase conductors. Where the service-entrance conductors are paralleled in two or more raceways or cables, the equipment bonding jumper, where routed with the raceways or cables, shall be run in parallel. The size of the bonding jumper for each raceway or cable shall be based on the size of the service-entrance conductors in each raceway or cable.

(d) **Size — Equipment Bonding Jumper on Load Side of Service.** The equipment bonding jumper on the load side of the service overcurrent devices shall not be smaller than the sizes listed by Table 250-95 for equipment grounding conductors. A single common continuous equipment bonding jumper shall be permitted to bond two or more raceways or cables where the bonding jumper is sized in accordance with Table 250-95 for the largest overcurrent device supplying circuits therein.

*Exception: The equipment bonding jumper shall not be required to be larger than the circuit conductors supplying the equipment, but shall not be smaller than No. 14 AWG.*

(e) **Installation — Equipment Bonding Jumper.** The equipment bonding jumper shall be permitted to be installed inside or outside of a raceway or enclosure. Where installed on the outside, the length of the equipment bonding jumper shall not exceed 6 feet (1.83 m) and shall be routed with the raceway or enclosure. Where installed inside of a raceway, the equipment bonding jumper shall comply with the requirements of Section 310-12(b).

## 250-80. Bonding of Piping Systems.

(a) **Metal Water Piping.** The interior metal water piping system shall be bonded to the service equipment enclosure, the grounded conductor at the service, the grounding electrode conductor where of sufficient size, or to the one or more grounding electrodes used. The bonding jumper shall be sized in accordance with Table 250-94. The points of attachment of the bonding jumper shall be accessible.

*Exception: In buildings of multiple occupancy, where the interior metal water piping system for the individual occupancies is metallicity isolated from all other occupancies by use of nonmetallic water piping, the interior metal water piping system for each occupancy shall be permitted to be bonded to the panelboard or switchboard enclosure (other than service equipment) supplying that occupancy. The bonding jumper shall be sized in accordance with Table 250-95.*

(b) **Other Metal Piping.** Interior metal piping which may become energized shall be bonded to the service equipment enclosure, the grounded conductor at the service, the grounding electrode conductor where of sufficient size, or to the one or more grounding electrodes used. The bonding



jumper shall be sized in accordance with Table 250-95 using the rating of the circuit which may energize the piping.

The equipment grounding conductor for the circuit which may energize the piping shall be permitted to serve as the bonding means.

(FPN): Bonding all piping and metal air ducts within the premises will provide additional safety.

## H. Grounding Electrode System

**250-81. Grounding Electrode System.** If available on the premises at each building or structure served, each item (a) through (d) below shall be bonded together to form the grounding electrode system. The bonding jumper shall be installed in accordance with Section 250-92(a), shall be sized in accordance with Section 250-94, and shall be connected in the manner specified in Section 250-115. The unspliced grounding electrode conductor shall be permitted to run to any convenient grounding electrode available in the grounding electrode system. It shall be sized for the largest grounding electrode conductor required among all the available electrodes.

(a) **Metal Underground Water Pipe:** A metal underground water pipe in direct contact with the earth for 10 feet (3.05 m) or more (including any metal well casing effectively bonded to the pipe) and electrically continuous (or made electrically continuous by bonding around insulating joints or sections or insulating pipe) to the points of connection of the grounding electrode conductor and the bonding conductors. Continuity of the grounding path or the bonding connection to interior piping shall not rely on water meters. A metal underground water pipe shall be supplemented by an additional electrode of a type specified in Section 250-81 or in Section 250-83. The supplemental electrode shall be permitted to be bonded to the grounding electrode conductor, the grounded service-entrance conductor, the grounded service raceway, any grounded service enclosure, or the interior metal water piping at any convenient point.

Where the supplemental electrode is a made electrode as in Section 250-83 (c) or (d), that portion of the bonding jumper which is the sole connection to the supplemental grounding electrode shall not be required to be larger than No. 6 copper wire or No. 4 aluminum wire.

(b) **Metal Frame of the Building.** The metal frame of the building, where effectively grounded.

(c) **Concrete-Encased Electrode.** An electrode encased by at least 2 inches (50.8 mm) of concrete, located within and near the bottom of a concrete foundation or footing that is in direct contact with the earth, consisting of at least 20 feet (6.1 m) of one or more steel reinforcing bars or rods of not less than ½ inch (12.7 mm) diameter, or consisting of at least 20 feet (6.1 m) of bare copper conductor not smaller than No. 4 AWG.

(d) **Ground Ring.** A ground ring encircling the building or structure, in direct contact with the earth at a depth below earth surface not less than 2 ½ feet (762 mm), consisting of at least 20 feet (6.1 m) of bare copper conductor not smaller than No. 2 AWG.

**250-83. Made and Other Electrodes.** Where none of the electrodes specified in Section 250-81 is available, one or more of the electrodes specified in (a) through (d) below shall be used. Where practicable, made electrodes shall

be embedded below permanent moisture level. Made electrodes shall be free from nonconductive coatings, such as paint or enamel. Where more than one electrode is used, each electrode of one grounding system (including that used for lightning rods) shall not be less than 6 feet (1.83 m) from any other electrode of another grounding system.

(FPN): Two or more electrodes that are effectively bonded together are to be treated as a single electrode system in this sense.

(a) **Metal Underground Gas Piping System.** An electrically continuous metal underground gas piping system that is uninterrupted with insulating sections or joints and without an outer nonconductive coating, and then only if acceptable to and expressly permitted by both the serving gas supplier and the authority having jurisdiction.

(b) **Other Local Metal Underground Systems or Structures.** Other local metal underground systems or structures, such as piping systems and underground tanks.

(c) **Rod and Pipe Electrodes.** Rod and pipe electrodes shall not be less than 8 feet (2.44 m) in length and shall consist of the following materials, and shall be installed in the following manner:

(1) Electrodes of pipe or conduit shall not be smaller than ¾-inch trade size and, where of iron or steel, shall have the outer surface galvanized or otherwise metal-coated for corrosion protection.

(2) Electrodes of rods of steel or iron shall be at least ⅝ inch (15.87 mm) in diameter. Nonferrous rods or their equivalent shall be listed and shall be not less than ½ inch (12.7 mm) in diameter.

(3) The electrode shall be installed such that at least 8 feet (2.44 m) of length is in contact with the soil. It shall be driven to a depth of not less than 8 feet (2.44 m) except that where rock bottom is encountered, the electrode shall be driven at an oblique angle not to exceed 45 degrees from the vertical or shall be buried in a trench that is at least 2½ feet (762 mm) deep. The upper end of the electrode shall be flush with or below ground level unless the aboveground end and the grounding electrode conductor attachment are protected against physical damage as specified in Section 250-117.

(d) **Plate Electrodes.** Each plate electrode shall expose not less than 2 square feet (0.186 sq m) of surface to exterior soil. Electrodes of iron or steel plates shall be at least ¼ inch (6.35 mm) in thickness. Electrodes of nonferrous metal shall be at least 0.06 inch (1.52 mm) in thickness.

**250-84. Resistance of Made Electrodes.** A single electrode consisting of a rod, pipe, or plate which does not have a resistance to ground of 25 ohms or less shall be augmented by one additional electrode of any of the types specified in Section 250-81 or 250-83. Where multiple rod, pipe, or plate electrodes are installed to meet the requirements of this section, they shall be not less than 6 feet (1.83 m) apart.

(FPN): The paralleling efficiency of rods longer than 8 feet (2.44 m) is improved by spacing greater than 6 feet (1.83 m).

**250-86. Use of Lightning Rods.** Lightning rod conductors and driven pipes, rods, or other made electrodes used for grounding lightning rods shall not be used in lieu of the made grounding electrodes required by Section 250-83 for grounding wiring systems and equipment. This provision shall not

prohibit the required bonding together of grounding electrodes of different systems.

(FPN): See Sections 250-46, 800-31(b)(7), and 820-22(h).

(FPN): Bonding together of all separate grounding electrodes will limit potential differences between them and between their associated wiring systems.

## J. Grounding Conductors

**250-91. Material.** The material for grounding conductors shall be as specified in (a), (b), and (c) below.

**(a) Grounding Electrode Conductor.** The grounding electrode conductor shall be of copper, aluminum, or copper-clad aluminum. The material selected shall be resistant to any corrosive condition existing at the installation or shall be suitably protected against corrosion. The conductor shall be solid or stranded, insulated, covered, or bare and shall be installed in one continuous length without a splice or joint.

*Exception No. 1: Splices in busbars shall be permitted.*

*Exception No. 2: Where a service consists of more than a single enclosure as permitted in Section 230-40, Exception No. 2, it shall be permissible to connect taps to the grounding electrode conductor. Each such tap conductor shall extend to the inside of each such enclosure. The grounding electrode conductor shall be sized in accordance with Section 250-94, but the tap conductors shall be permitted to be sized in accordance with the grounding electrode conductors specified in Section 250-94 for the largest conductor serving the respective enclosures.*

**(b) Types of Equipment Grounding Conductors.** The equipment grounding conductor run with or enclosing the circuit conductors shall be one or more or a combination of the following: (1) a copper or other corrosion-resistant conductor. This conductor shall be solid or stranded; insulated, covered, or bare; and in the form of a wire or a busbar of any shape; (2) rigid metal conduit; (3) intermediate metal conduit; (4) electrical metallic tubing; (5) flexible metal conduit where both the conduit and fittings are listed for grounding; (6) armor of Type AC cable; (7) the sheath of mineral-insulated, metal-sheathed cable; (8) the metallic sheath or the combined metallic sheath and grounding conductors of Type MC cable; (9) cable trays as permitted in Sections 318-3(c) and 318-7; (10) other electrically continuous metal raceways listed for grounding.

*Exception No. 1: Flexible metal conduit and flexible metallic tubing shall be permitted for grounding if all the following conditions are met:*

*a. The length in any ground return path does not exceed 6 feet (1.83 m).*

*b. The circuit conductors contained therein are protected by overcurrent devices rated at 20 amperes or less.*

*c. The conduit or tubing is terminated in fittings listed for grounding.*

*Exception No. 2: Liquidtight flexible metal conduit shall be permitted as a grounding means in the 1/4-inch and smaller trade sizes if the total length of any ground return path is 6 feet (1.83 m) or less, the conduit is terminated in fittings listed for grounding, and the circuit conductors contained therein are protected by overcurrent devices rated at 20 amperes or less for 3/8-inch and 1/2-inch trade sizes and 60 amperes or less for 3/4-inch through 1 1/4-inch trade sizes.*

*Exception No. 3: For direct-current circuits only, the equipment grounding conductor shall be permitted to be run separately from the circuit conductors.*

**(c) Supplementary Grounding.** Supplementary grounding electrodes shall be permitted to augment the equipment grounding conductors specified in Section 250-91(b), but the earth shall not be used as the sole equipment grounding conductor.

**250-92. Installation.** Grounding conductors shall be installed as specified in (a), (b), and (c) below.

**(a) Grounding Electrode Conductor.** A grounding electrode conductor or its enclosure shall be securely fastened to the surface on which it is carried. A No. 4, copper or aluminum, or larger conductor shall be protected if exposed to severe physical damage. A No. 6 grounding conductor that is free from exposure to physical damage shall be permitted to be run along the surface of the building construction without metal covering or protection where it is securely fastened to the construction; otherwise, it shall be in rigid metal conduit, intermediate metal conduit, rigid nonmetallic conduit, electrical metallic tubing, or cable armor. Grounding conductors smaller than No. 6 shall be in rigid metal conduit, intermediate metal conduit, rigid nonmetallic conduit, electrical metallic tubing, or cable armor.

Aluminum or copper-clad aluminum grounding conductors shall not be used where in direct contact with masonry or the earth or where subject to corrosive conditions. Where used outside, aluminum or copper-clad aluminum grounding conductors shall not be installed within 18 inches (457 mm) of the earth.

**(b) Enclosures for Grounding Electrode Conductors.** Metal enclosures for grounding conductors shall be electrically continuous from the point of attachment to cabinets or equipment to the grounding electrode, and shall be securely fastened to the ground clamp or fitting. Metal enclosures that are not physically continuous from cabinet or equipment to the grounding electrode shall be made electrically continuous by bonding each end to the grounding conductor. Where intermediate metal conduit is used for protection for a grounding conductor, the installation shall comply with the requirements of Article 345. Where rigid metal conduit is used as protection for a grounding conductor, the installation shall comply with the requirements of Article 346. Where rigid nonmetallic conduit is used as protection for a grounding conductor, the installation shall comply with the requirements of Article 347. Where electrical metallic tubing is used, the installation shall comply with the requirements of Article 348.

**(c) Equipment Grounding Conductor.** An equipment grounding conductor shall be installed as follows.

(1) Where it consists of a raceway, cable tray, cable armor, or cable sheath or where it is a wire within a raceway or cable, it shall be installed in accordance with the applicable provisions in this Code using fittings for joints and terminations approved for use with the type raceway or cable used. All connections, joints, and fittings shall be made tight using suitable tools.

(2) Where it is a separate equipment grounding conductor as provided in the Exception for Section 250-50(a) and (b), it shall be installed in accordance with (a) above in regard to restrictions for aluminum and also in regard to protection from physical damage.

*Exception: Sizes smaller than No. 6 shall not be required to be enclosed in a raceway or armor where run in the hollow spaces of a wall or partition or where otherwise installed so as not to be subject to physical damage.*

**250-93. Size of Direct-Current System Grounding Conductor.** The size of the grounding conductor for a dc system shall be as specified in (a) through (c) below.

**(a) Not Be Smaller than the Neutral Conductor.** Where the dc system consists of a 3-wire balancer set or a balancer winding with overcurrent protection as provided in Section 445-4(d), the grounding conductor shall not be smaller than the neutral conductor.

**(b) Not Be Smaller than the Largest Conductor.** Where the dc system is other than as in (a) above, the grounding conductor shall not be smaller than the largest conductor supplied by the system.

**(c) Not Be Smaller than No. 8.** In no case shall the grounding conductor be smaller than No. 8 copper or No. 6 aluminum.

**250-94. Size of Alternating-Current Grounding Electrode Conductor.** The size of the grounding electrode conductor of a grounded or ungrounded ac system shall not be less than given in Table 250-94.

*Exception No. 1: Grounded Systems.*

*a. Where connected to made electrodes as in Section 250-83 (c) or (d), that portion of the grounding electrode conductor which is the sole connection to the grounding electrode shall not be required to be larger than No. 6 copper wire or No. 4 aluminum wire.*

*b. Where connected to a concrete-encased electrode as in Section 250-81(c), that portion of the grounding electrode conductor which is the sole connection to the grounding electrode shall not be required to be larger than No. 4 copper wire.*

*c. Where connected to a ground ring as in Section 250-81(d), that portion of the grounding electrode conductor which is the sole connection to the grounding electrode shall not be required to be larger than the conductor used for the ground ring.*

*Exception No. 2: Ungrounded Systems.*

*a. Where connected to made electrodes as in Section 250-83 (c) or (d), that portion of the grounding electrode conductor which is the sole connection to the grounding electrode shall not be required to be larger than No. 6 copper wire or No. 4 aluminum wire.*

*b. Where connected to a concrete-encased electrode as in Section 250-81(c), that portion of the grounding electrode conductor which is the sole connection to the grounding electrode shall not be required to be larger than No. 4 copper wire.*

*c. Where connected to a ground ring as in Section 250-81(d), that portion of the grounding electrode conductor which is the sole connection to the grounding electrode shall not be required to be larger than the conductor used for the ground ring.*

**250-95. Size of Equipment Grounding Conductors.** The size of copper, aluminum, or copper-clad aluminum equipment grounding conductors shall not be less than given in Table 250-95.

**Table 250-94**  
**Grounding Electrode Conductor for AC Systems**

Size of Largest Service-Entrance Conductor or Equivalent Area for Parallel Conductors		Size of Grounding Electrode Conductor	
Copper	Aluminum or Copper-Clad Aluminum	Copper	*Aluminum or Copper-Clad Aluminum
2 or smaller	0 or smaller	8	6
1 or 0	2/0 or 3/0	6	4
2/0 or 3/0	4/0 or 250 MCM	4	2
Over 3/0 thru 350 MCM	Over 250 MCM thru 500 MCM	2	0
Over 350 MCM thru 600 MCM	Over 500 MCM thru 900 MCM	0	3/0
Over 600 MCM thru 1100 MCM	Over 900 MCM thru 1750 MCM	2/0	4/0
Over 1100 MCM	Over 1750 MCM	3/0	250 MCM

Where there are no service-entrance conductors, the grounding electrode conductor size shall be determined by the equivalent size of the largest service-entrance conductor required for the load to be served.

\* See installation restrictions in Section 250-92 (a).

(FPN): See Section 250-23 (b).

Where conductors are run in parallel in multiple raceways, as permitted in Section 310-4, the equipment grounding conductor, where used, shall be run in parallel. Each parallel equipment grounding conductor shall be sized on the basis of the ampere rating of the overcurrent device protecting the circuit conductors in the raceway in accordance with Table 250-95.

When conductors are adjusted in size to compensate for voltage drop, equipment grounding conductors, where required, shall be adjusted proportionately according to circular mil area.

Where a single equipment grounding conductor is run with multiple circuits in the same raceway, it shall be sized for the largest overcurrent device protecting conductors in the raceway.

*Exception No. 1: An equipment grounding conductor not smaller than No. 18 copper and not smaller than the circuit conductors if an integral part of a listed flexible cord assembly shall be permitted for grounding cord-connected equipment where the equipment is protected by overcurrent devices not exceeding 20-ampere rating.*

*Exception No. 2: The equipment grounding conductor shall not be required to be larger than the circuit conductors supplying the equipment.*

*Exception No. 3: Where a raceway or a cable armor or sheath is used as the equipment grounding conductor, as provided in Sections 250-57(a) and 250-91(b).*

**250-97. Outline Lighting.** Isolated noncurrent-carrying metal parts of outline lighting systems shall be permitted to be bonded together by a No. 14 copper or No. 12 aluminum conductor protected from physical damage,

**Table 250-95. Minimum Size Equipment Grounding Conductors for Grounding Raceway and Equipment**

Rating or Setting of Automatic Overcurrent Device in Circuit Ahead of Equipment, Conduit, etc., Not Exceeding (Amperes)	Size	
	Copper Wire No.	Aluminum or Copper-Clad Aluminum Wire No.*
15	14	12
20	12	10
30	10	8
40	10	8
60	10	8
100	8	6
200	6	4
300	4	2
400	3	1
500	2	1/0
600	1	2/0
800	0	3/0
1000	2/0	4/0
1200	3/0	250 MCM
1600	4/0	350 "
2000	250 MCM	400 "
2500	350 "	600 "
3000	400 "	600 "
4000	500 "	800 "
5000	700 "	1200 "
6000	800 "	1200 "

\* See installation restrictions in Section 250-92(a).

where a conductor complying with Section 250-95 is used to ground the group.

### 250-99. Equipment Grounding Conductor Continuity.

(a) **Separable Connections.** Separable connections such as those provided in draw-out equipment or attachment plugs and mating connectors and receptacles shall provide for first-make, last-break of the equipment grounding conductor.

*Exception: Interlocked equipment, plugs, receptacles and connectors which preclude energization without grounding continuity.*

(b) **Switches.** No automatic cutout or switch shall be placed in the equipment grounding conductor of a premises wiring system.

*Exception: Where the opening of the cutout or switch disconnects all sources of energy.*

### K. Grounding Conductor Connections

**250-112. To Grounding Electrode.** The connection of a grounding electrode conductor to a grounding electrode shall be accessible and made in a manner that will assure a permanent and effective ground. Where necessary to assure this for a metal piping system used as a grounding electrode, effective bonding shall be provided around insulated joints and sections and around any equipment that is likely to be disconnected for repairs or replacement.

*Exception: An encased or buried connection to a concrete-encased, driven, or buried grounding electrode shall not be required to be accessible.*

**250-113. To Conductors and Equipment.** Grounding conductors and bonding jumpers shall be connected by exothermic welding, listed pressure connectors, listed clamps, or other listed means. Connection devices or fittings that depend solely on solder shall not be used.

**250-114. Continuity and Attachment of Branch-Circuit Equipment Grounding Conductors to Boxes.** Where more than one equipment grounding conductor enters a box all such conductors shall be spliced or joined within the box or to the box with devices suitable for the use. Connections depending solely on solder shall not be used. Splices shall be made in accordance with Section 110-14(b) except that insulation shall not be required. The arrangement of grounding connections shall be such that the disconnection or the removal of a receptacle, fixture, or other device fed from the box will not interfere with or interrupt the grounding continuity.

(a) **Metal Boxes.** A connection shall be made between the one or more equipment grounding conductors and a metal box by means of a grounding screw which shall be used for no other purpose, or a listed grounding device.

(b) **Nonmetallic Boxes.** One or more equipment grounding conductors brought into a nonmetallic outlet box shall be so arranged that a connection can be made to any fitting or device in that box requiring grounding.

**250-115. Connection to Electrodes.** The grounding conductor shall be connected to the grounding fitting by exothermic welding, listed lugs, listed pressure connectors, listed clamps, or other listed means. Connections depending on solder shall not be used. Ground clamps shall be listed for the materials of the grounding electrode and the grounding electrode conductor and where used on pipe, rod or other buried electrodes shall also be listed for direct soil burial. Not more than one conductor shall be connected to the grounding electrode by a single clamp or fitting unless the clamp or fitting is listed for multiple conductors. One of the methods indicated in (a), (b), (c), or (d) below shall be used.

(a) **Bolted Clamp.** A listed bolted clamp of cast bronze or brass, or plain or malleable iron.

(b) **Pipe Fitting, Pipe Plug, etc.** A pipe fitting, pipe plug, or other approved device screwed into a pipe or pipe fitting.

(c) **Sheet-Metal-Strap Type Ground Clamp.** A listed sheet-metal-strap type ground clamp having a rigid metal base that seats on the electrode and having a strap of such material and dimensions that it is not likely to stretch during or after installation.



(d) **Other Means.** An equally substantial approved means.

**250-117. Protection of Attachment.** Ground clamps or other fittings shall be approved for general use without protection or shall be protected from ordinary physical damage as indicated in (a) or (b) below.

(a) **Not Likely to Be Damaged.** Installations where they are not likely to be damaged.

(b) **Protective Covering.** Enclosing in metal, wood, or equivalent protective covering.

**250-118. Clean Surfaces.** Nonconductive coatings (such as paint, lacquer, and enamel) on equipment to be grounded shall be removed from threads and other contact surfaces to assure good electrical continuity.

#### L. Instrument Transformers, Relays, etc.

**250-121. Instrument Transformer Circuits.** Secondary circuits of current and potential instrument transformers shall be grounded where the primary windings are connected to circuits of 300 volts or more to ground, and where on switchboards, shall be grounded irrespective of voltage.

*Exception: Circuits where the primary windings are connected to circuits of less than 1000 volts with no live parts or wiring exposed or accessible to other than qualified persons.*

**250-122. Instrument Transformer Cases.** Cases or frames of instrument transformers shall be grounded where accessible to other than qualified persons.

*Exception: Cases or frames of current transformers, the primaries of which are not over 150 volts to ground and which are used exclusively to supply current to meters.*

**250-123. Cases of Instruments, Meters, and Relays — Operating at Less than 1000 Volts.** Instruments, meters, and relays operating with windings or working parts at less than 1000 volts shall be grounded as specified in (a), (b), or (c) below.

(a) **Not on Switchboards.** Instruments, meters, and relays not located on switchboards, operating with windings or working parts at 300 volts or more to ground, and accessible to other than qualified persons, shall have the cases and other exposed metal parts grounded.

(b) **On Dead-Front Switchboards.** Instruments, meters, and relays (whether operated from current and potential transformers, or connected directly in the circuit) on switchboards having no live parts on the front of the panels shall have the cases grounded.

(c) **On Live-Front Switchboards.** Instruments, meters, and relays (whether operated from current and potential transformers, or connected directly in the circuit) on switchboards having exposed live parts on the front of panels shall not have their cases grounded. Mats of insulating rubber or other suitable floor insulation shall be provided for the operator where the voltage to ground exceeds 150.

**250-124. Cases of Instruments, Meters, and Relays — Operating Voltage 1 kV and Over.** Where instruments, meters, and relays have current-carrying

parts of 1 kV, and over to ground, they shall be isolated by elevation or protected by suitable barriers, grounded metal or insulating covers or guards. Their cases shall not be grounded.

*Exception: Cases of electrostatic ground detectors where the internal ground segments of the instrument are connected to the instrument case and grounded and the ground detector is isolated by elevation.*

**250-125. Instrument Grounding Conductor.** The grounding conductor for secondary circuits of instrument transformers and for instrument cases shall not be smaller than No. 12 copper or No. 10 aluminum. Cases of instrument transformers, instruments, meters, and relays which are mounted directly on grounded metal surfaces of enclosures or grounded metal switchboard panels shall be considered to be grounded and no additional grounding conductor will be required.

### M. Grounding of Systems and Circuits of 1 kV and Over (High Voltage)

**250-150. General.** Where high-voltage systems are grounded, they shall comply with all applicable provisions of the preceding sections of this article and with the following sections which supplement and modify the preceding sections.

**250-151. Derived Neutral Systems.** A system neutral derived from a grounding transformer shall be permitted to be used for grounding a high-voltage system.

#### **250-152. Solidly Grounded Neutral Systems.**

(a) **Neutral Conductor.** The neutral of a solidly grounded neutral system shall comply with (1) and (2) below.

(1) The minimum insulation level for neutral conductors of solidly grounded systems shall be 600 volts.

*Exception No. 1: Bare copper conductors shall be permitted to be used for the neutral of service entrances and the neutral of direct buried portions of feeders.*

*Exception No. 2: Bare conductors shall be permitted for the neutral of overhead portions installed outdoors.*

(FPN): See Section 225-4 for conductor covering where within 10 feet (3.05 m) of any building or other structure.

(2) The neutral grounding conductor shall be permitted to be a bare conductor if isolated from phase conductors and protected from physical damage.

(b) **Multiple Grounding.** The neutral of a solidly grounded neutral system shall be permitted to be grounded at more than one point for:

(1) Services.

(2) Direct buried portions of feeders employing a bare copper neutral.

(3) Overhead portion installed outdoors.

**250-153. Impedance Grounded Neutral Systems.** Impedance grounded neutral systems shall comply with the provisions of (a) through (d) below.

(a) **Location.** The grounding impedance shall be inserted in the grounding conductor between the grounding electrode of the supply system and the neutral point of the supply transformer or generator.

(b) **Identified and Insulated.** Where the neutral conductor of an impedance grounded neutral system is used, it shall be identified, as well as fully insulated with the same insulation as the phase conductors.

(c) **System Neutral Connection.** The system neutral shall not be connected to ground, except through the neutral grounding impedance.

(d) **Equipment Grounding Conductors.** Equipment grounding conductors shall be permitted to be bare and shall be connected to the ground bus and grounding electrode conductor at the service-entrance equipment and extended to the system ground.

**250-154. Grounding of Systems Supplying Portable or Mobile Equipment.** Systems supplying portable or mobile high-voltage equipment, other than substations installed on a temporary basis, shall comply with (a) through (e) below.

(a) **Portable or Mobile Equipment.** Portable or mobile high-voltage equipment shall be supplied from a system having its neutral grounded through an impedance. Where a delta-connected high-voltage system is used to supply portable or mobile equipment, a system neutral shall be derived.

(b) **Exposed Noncurrent-Carrying Metal Parts.** Exposed noncurrent-carrying metal parts of portable or mobile equipment shall be connected by an equipment grounding conductor to the point at which the system neutral impedance is grounded.

(c) **Ground-Fault Current.** The voltage developed between the portable or mobile equipment frame and ground by the flow of maximum ground-fault current shall not exceed 100 volts.

(d) **Ground-Fault Detection and Relaying.** Ground-fault detection and relaying shall be provided to automatically de-energize any high-voltage system component which has developed a ground fault. The continuity of the equipment grounding conductor shall be continuously monitored so as to de-energize automatically the high-voltage feeder to the portable or mobile equipment upon loss of continuity of the equipment grounding conductor.

(e) **Isolation.** The grounding electrode to which the portable or mobile equipment system neutral impedance is connected shall be isolated from and separated in the ground by at least 20 feet (6.1 m) from any other system or equipment grounding electrode, and there shall be no direct connection between the grounding electrodes, such as buried pipe, fence, etc.

(f) **Trailing Cable and Couplers.** High voltage trailing cable and couplers for interconnection of portable or mobile equipment shall meet the requirements of Part C of Article 400 for cables and Section 710-45 for couplers.

**250-155. Grounding of Equipment.** All noncurrent-carrying metal parts of fixed, portable, and mobile equipment and associated fences, housings, enclosures, and supporting structures shall be grounded.

*Exception No. 1: Where isolated from ground and located so as to prevent any person who can make contact with ground from contacting such metal parts when the equipment is energized.*

*Exception No. 2: Pole-mounted distribution apparatus as provided in Section 250-42, Exception No. 3.*

Grounding conductors not an integral part of a cable assembly shall not be smaller than No. 6 copper or No. 4 aluminum.

## ARTICLE 280 — SURGE ARRESTERS

### A. General

**280-1. Scope.** This article covers general requirements, installation requirements, and connection requirements for surge arresters installed on premises wiring systems.

**280-2. Definition.** A surge arrester is a protective device for limiting surge voltages by discharging or bypassing surge current, and it also prevents continued flow of follow current while remaining capable of repeating these functions.

**280-3. Number Required.** Where used at a point on a circuit, a surge arrester shall be connected to each ungrounded conductor. A single installation of such surge arresters shall be permitted to protect a number of interconnected circuits provided that no circuit is exposed to surges while disconnected from the surge arresters.

#### 280-4. Surge Arrester Selection.

(a) **On Circuits of Less than 1000 Volts.** The rating of the surge arrester shall be equal to or greater than the maximum continuous phase-to-ground power frequency voltage available at the point of application.

(b) **On Circuits of 1 kV and Over — Silicon Carbide Types.** The rating of a silicon carbide-type surge arrester shall be not less than 125 percent of the maximum continuous phase-to-ground voltage available at the point of application.

(FPN): For further information on selection of surge arresters, see Guide for the Application of Valve-Type Surge Arresters for Alternating-Current Systems (ANSI C62.2-1981).

(FPN): Metal oxide surge arrester ratings are based on the magnitude and duration of overvoltage at the arrester location as affected by phase-to-ground faults, system grounding techniques, switching surges, and other causes. See manufacturer's application rules for the specific arrester to be used at a particular location.

### B. Installation

**280-11. Location.** Surge arresters shall be permitted to be located indoors or outdoors and shall be made inaccessible to unqualified persons.

*Exception: Surge arresters listed for installation in accessible locations.*

**280-12. Routing of Surge Arrester Connections.** The conductor used to connect the surge arrester to line or bus and to ground shall not be any longer than necessary and shall avoid unnecessary bends.

### C. Connecting Surge Arresters

**280-21. Installed at Services of Less than 1000 Volts.** Line and ground connecting conductors shall not be smaller than No. 14 copper or No. 12 aluminum. The arrester grounding conductor shall be connected to one of the following: (1) the grounded service conductor; (2) the grounding electrode conductor; (3) the grounding electrode for the service; or (4) the equipment grounding terminal in the service equipment.

**280-22. Installed on the Load Side of Services of Less than 1000 Volts.** Line and ground connecting conductors shall not be smaller than No. 14 copper or No. 12 aluminum. A surge arrester shall be permitted to be connected between any two conductors (ungrounded conductor(s), grounded conductor, grounding conductor). The grounded conductor and the grounding conductor shall be interconnected only by the normal operation of the surge arrester during a surge.

**280-23. Circuits of 1 kV and Over — Surge-Arrester Conductors.** The conductor between the surge arrester and the line and surge arrester and the grounding connection shall not be smaller than No. 6 copper or aluminum.

**280-24. Circuits of 1 kV and Over — Interconnections.** The grounding conductor of a surge arrester protecting a transformer that supplies a secondary distribution system shall be interconnected as specified in (a) or (b) below.

**(a) Metallic Interconnections.** A metallic interconnection shall be made to the secondary grounded circuit conductor or the secondary circuit grounding conductor provided that, in addition to the direct grounding connection at the surge arrester:

(1) The grounded conductor of the secondary has elsewhere a grounding connection to a continuous metal underground water piping system. However, in urban water-pipe areas where there are at least four water-pipe connections on the neutral and not less than four such connections in each mile of neutral, the metallic interconnection shall be permitted to be made to the secondary neutral with omission of the direct grounding connection at the surge arrester.

(2) The grounded conductor of the secondary system is a part of a multiground neutral system of which the primary neutral has at least four ground connections in each mile of line in addition to a ground at each service.

**(b) Through Spark Gap or Device.** Where the surge arrester grounding conductor is not connected as in (a) above or where the secondary is not grounded as in (a) above but is otherwise grounded as in Sections 250-81 and 250-83, an interconnection shall be made through a spark gap or listed device as follows:

(1) For ungrounded or ungrounded primary systems, the spark gap or listed device shall have a 60 hertz breakdown voltage of at least twice the primary circuit voltage but not necessarily more than 10 kV, and there shall be at least one other ground on the grounded conductor of the secondary not less than 20 feet (6.1 m) distant from the surge arrester grounding electrode.

(2) For multigrounded neutral primary systems, the spark gap or listed device shall have a 60 hertz breakdown or not more than 3 kV, and there shall

be at least one other ground on the grounded conductor of the secondary not less than 20 feet (6.1 m) distant from the surge arrester grounding electrode.

**(c) By Special Permission.** An interconnection of the surge arrester ground and the secondary neutral, other than as provided in (a) or (b) above, shall be permitted to be made only by special permission.

**280-25. Grounding.** Except as indicated in this article, surge arrester grounding connections shall be made as specified in Article 250. Grounding conductors shall not be run in metal enclosures unless bonded to both ends of such enclosure.



## Chapter 3. Wiring Methods and Materials

### ARTICLE 300 — WIRING METHODS

#### A. General Requirements

##### 300-1. Scope.

(a) **All Wiring Installations.** This article covers wiring methods for all wiring installations.

*Exception No. 1: Only those sections referenced in Article 725 shall apply to Class 1, Class 2, and Class 3 circuits.*

*Exception No. 2: Only those sections referenced in Article 760 shall apply to fire protective signaling circuits.*

*Exception No. 3: Only those sections referenced in Article 770 shall apply to optical fiber cables.*

*Exception No. 4: Only those sections referenced in Article 800 shall apply to communication systems.*

*Exception No. 5: Only those sections referenced in Article 820 shall apply to community antenna television and radio distribution systems.*

(b) **Integral Parts of Equipment.** The provisions of this article are not intended to apply to the conductors which form an integral part of equipment, such as motors, controllers, motor control centers, or factory-assembled control equipment.

##### 300-2. Limitations.

(a) **Voltage.** Wiring methods specified in Chapter 3 shall be used for voltages 600 volts, nominal, or less where not specifically limited in some section of Chapter 3. They shall be permitted for voltages over 600 volts, nominal, where specifically permitted elsewhere in this Code.

(b) **Temperature.** Temperature limitation of conductors shall be in accordance with Section 310-10.

##### 300-3. Conductors.

(a) **Single Conductors.** Single conductors specified in Table 310-13 shall only be permitted to be installed where part of a recognized wiring method of Chapter 3.

(b) **Conductors of the Same Circuit.** All conductors of the same circuit and, where used, the neutral and all equipment grounding conductors shall be contained within the same raceway, cable tray, trench, cable, or cord.

*Exception to (a) and (b): As permitted in Sections 250-57(b), 250-79(e), 300-5(i), 300-20(a), 318-8(d), and 339-3(a)(2).*

##### (c) Conductors of Different Systems.

(1) **600 Volts, Nominal, or Less.** Conductors of 600 volts, nominal, or less, alternating current and direct current circuits, shall be permitted to occupy the same equipment wiring enclosure, cable, or raceway. All con-



ductors shall have an insulation rating equal to at least the maximum nominal circuit voltage rating of any conductor within the enclosure, cable, or raceway.

*Exception: For solar photovoltaic systems in accordance with Section 690-4(b).*

(FPN): See Section 725-38(a)(2) for Class 2 and Class 3 circuit conductors.

**(2) Over 600 Volts, Nominal.** Conductors of circuits rated over 600 volts, nominal, shall not occupy the same equipment wiring enclosure, cable, or raceway with conductors of circuits rated 600 volts, nominal, or less.

(FPN): See Section 300-32, Conductors of Different Systems — over 600 volts, nominal.

*Exception No. 1: Secondary wiring to electric-discharge lamps of 1000 volts or less, if insulated for the secondary voltage involved, shall be permitted to occupy the same fixture enclosure as the branch-circuit conductors.*

*Exception No. 2: Primary leads of electric-discharge lamp ballasts, insulated for the primary voltage of the ballast, when contained within the individual wiring enclosure, shall be permitted to occupy the same fixture enclosure as the branch-circuit conductors.*

*Exception No. 3: Excitation, control, relay, and ammeter conductors used in connection with any individual motor or starter shall be permitted to occupy the same enclosure as the motor circuit conductors.*

**300-4. Protection Against Physical Damage.** Where subject to physical damage, conductors shall be adequately protected.

**(a) Cables and Raceways Through Wood Members.**

**(1) Bored Holes.** In both exposed and concealed locations, where a cable or raceway-type wiring method is installed through bored holes in joists, rafters, or wood members, holes shall be bored so that the edge of the hole is not less than 1/4 inches (31.8 mm) from the nearest edge of the wood member. Where this distance cannot be maintained the cable or raceway shall be protected from penetration by screws or nails by a steel plate or bushing, at least 1/16 inch (1.59 mm) thick, and of appropriate length and width installed to cover the area of the wiring.

*Exception: Raceways as covered in Articles 345, 346, 347, and 348.*

**(2) Notches in Wood.** Where there is no objection because of weakening the building structure, in both exposed and concealed locations, cables or raceways shall be permitted to be laid in notches in wood studs, joists, rafters, or other wood members where the cable or raceway at those points is protected against nails or screws by a steel plate at least 1/16 inch (1.59 mm) thick installed before the building finish is applied.

*Exception: Raceways as covered in Articles 345, 346, 347, and 348.*

**(b) Cables and Electrical Nonmetallic Tubing Through Metal Framing Members.**

**(1)** In both exposed and concealed locations where nonmetallic-sheathed cables pass through either factory or field punched, cut or drilled slots or holes in metal members, the cable shall be protected by bushings or grommets securely fastened in the opening prior to installation of the cable.

(2) Where nails or screws are likely to penetrate nonmetallic-sheathed cable or electrical nonmetallic tubing, a steel sleeve, steel plate or steel clip not less than  $\frac{1}{16}$ -inch (1.59 mm) in thickness shall be used to protect the cable or tubing.

(c) **Cables Through Spaces Behind Panels Designed to Allow Access.** Cables, or raceway-type wiring methods, installed behind panels designed to allow access shall be supported according to their applicable articles.

### 300-5. Underground Installations.

(a) **Minimum Cover Requirements.** Direct buried cable or conduit or other raceways shall be installed to meet the minimum cover requirements of Table 300-5.

**Cover:** Cover is defined as the shortest distance measured between a point on the top surface of any direct buried conductor, cable, conduit, or other raceway and the finished grade.

**Table 300-5**  
**Minimum Cover Requirements, 0 to 600 Volts, Nominal**

Wiring Method	Minimum Burial (Inches)
Direct Buried Cables	24
Rigid Metal Conduit	6
Intermediate Metal Conduit	6
Rigid Nonmetallic Conduit	
Approved for Direct Burial	
without Concrete Encasement	18
Other Approved Raceways*	18

For SI units: one inch = 25.4 millimeters.

\* Note: Raceways approved for burial only when concrete encased shall require a concrete envelope not less than 2 inches (50.8 mm) thick.

*Exception No. 1: The minimum cover requirements for other than rigid metal conduit and intermediate metal conduit shall be permitted to be reduced by 6 inches (152 mm) for installations where a 2-inch (50.8-mm) thick concrete pad or equivalent in physical protection is placed in the trench over the underground installation.*

*Exception No. 2: The minimum cover requirements shall not apply to conduits or other raceways which are located under a building or exterior concrete slab not less than 4 inches (102 mm) in thickness and extending not less than 6 inches (152 mm) beyond the underground installation.*

*Exception No. 3: Areas subject to vehicular traffic such as streets, highways, roads, alleys, driveways, and parking lots shall have a minimum cover of 24 inches (610 mm).*

*Exception No. 4: Residential branch circuits rated 300 volts or less and provided with overcurrent protection of not more than 30 amperes shall be permitted with a cover requirement of 12 inches (305 mm).*

*Exception No. 5: Lesser depths shall be permitted where cables and conductors rise for terminations or splices or where access is otherwise required.*

*Exception No. 6: In airport runways, including adjacent defined areas where trespass is prohibited, cable shall be permitted to be buried not less than 18 inches (457 mm) deep and without raceways, concrete encasement or equivalent.*

*Exception No. 7: Raceways installed in solid rock shall be permitted to be buried at a lesser depth when covered by 2 inches (50.8 mm) or more of concrete over the installation and extending down to the rock surface.*

*Exception No. 8: Circuits for the control of irrigation and landscape lighting systems which are limited to not more than 30 volts and are installed with Type UF or other identified cable or raceway shall be permitted with a minimum cover of 6 inches (152 mm).*

**(b) Grounding.** All underground installations shall be grounded and bonded in accordance with Article 250 of this Code.

**(c) Underground Cables Under Buildings.** Underground cable installed under a building shall be in a raceway that is extended beyond the outside walls of the building.

**(d) Protection from Damage.** Direct buried conductors and cables emerging from the ground shall be protected by enclosures or raceways extending from the minimum cover distance required by Section 300-5(a) in Table 300-5 (a) below grade to a point at least 8 feet (2.44 m) above finished grade. In no case shall the protection be required to exceed 18 inches (457 mm) below finished grade.

Conductors entering a building shall be protected to the point of entrance.

Where the enclosure or raceway is subject to physical damage the conductors shall be installed in rigid metal conduit, intermediate metal conduit, Schedule 80 rigid nonmetallic conduit or equivalent.

**(e) Splices and Taps.** Direct buried conductors or cables shall be permitted to be spliced or tapped without the use of splice boxes. The splices or taps shall be made by approved methods and with identified materials.

**(f) Backfill.** Backfill containing large rock, paving materials, cinders, large or sharply angular substance, or corrosive material shall not be placed in an excavation where materials may damage raceways, cables, or other substructures or prevent adequate compaction of fill or contribute to corrosion of raceways, cables or other substructures.

Where necessary to prevent physical damage to the raceway or cable, protection shall be provided in the form of granular or selected material, suitable running boards, suitable sleeves, or other approved means.

**(g) Raceway Seals.** Conduits or raceways through which moisture may contact energized live parts shall be sealed or plugged at either or both ends.

(FPN): Presence of hazardous gases or vapors may also necessitate sealing of underground conduits or raceways entering buildings.

**(h) Bushing.** A bushing, or terminal fitting, with an integral bushed opening shall be used at the end of a conduit or other raceway which terminates underground where the conductors or cables emerge as a direct burial wiring method. A seal incorporating the physical protection characteristics of a bushing shall be permitted to be used in lieu of a bushing.

(i) **Single Conductors.** All conductors of the same circuit and, where used, the neutral and all equipment grounding conductors shall be installed in the same raceway or shall be installed in close proximity in the same trench.

*Exception No. 1: Conductors in parallel in raceways shall be permitted but each raceway shall contain all conductors of the same circuit including grounding conductors.*

*Exception No. 2: Isolated phase installations shall be permitted in non-metallic raceways in close proximity where conductors are paralleled as permitted in Section 310-4 and the conditions of Section 300-20 are met.*

**300-6. Protection Against Corrosion.** Metal raceways, cable armor, boxes, cable sheathing, cabinets, elbows, couplings, fittings, supports, and support hardware shall be of materials suitable for the environment in which they are to be installed.

(a) **General.** Ferrous raceways, cable armor, boxes, cable sheathing, cabinets, metal elbows, couplings, fittings, supports, and support hardware shall be suitably protected against corrosion inside and outside (except threads at joints) by a coating of approved corrosion-resistant material such as zinc, cadmium, or enamel. Where protected from corrosion solely by enamel, they shall not be used out-of-doors or in wet locations as described in (c) below. When boxes or cabinets have an approved system of organic coatings and are marked "Raintight," "Rainproof" or "Outdoor Type," they shall be permitted out-of-doors.

*Exception: Threads at joints shall be permitted to be coated with an identified electrically conductive compound.*

(b) **In Concrete or in Direct Contact with the Earth.** Ferrous or nonferrous metal raceways, cable armor, boxes, cable sheathing, cabinets, elbows, couplings, fittings, supports, and support hardware shall be permitted to be installed in concrete or in direct contact with the earth, or in areas subject to severe corrosive influences when made of material judged suitable for the condition, or when provided with corrosion protection approved for the condition.

(c) **Indoor Wet Locations.** In portions of dairies, laundries, canneries, and other indoor wet locations, and in locations where walls are frequently washed or where there are surfaces of absorbent materials, such as damp paper or wood, the entire wiring system, including all boxes, fittings, conduits, and cable used therewith, shall be mounted so that there is at least  $\frac{1}{4}$ -inch (6.35-mm) air space between it and the wall or supporting surface.

(FPN): In general, areas where acids and alkali chemicals are handled and stored may present such corrosive conditions, particularly when wet or damp. Severe corrosive conditions may also be present in portions of meat-packing plants, tanneries, glue houses, and some stables; installations immediately adjacent to a seashore and swimming pool areas; areas where chemical de-icers are used; and storage cellars or rooms for hides, casings, fertilizer, salt, and bulk chemicals.

**300-7. Raceways Exposed to Different Temperatures.**

(a) **Sealing.** Where portions of an interior raceway system are exposed to widely different temperatures, as in refrigerating or cold-storage plants, circulation of air from a warmer to a colder section through the raceway shall be prevented.

(b) **Expansion Joints.** Raceways shall be provided with expansion joints where necessary to compensate for thermal expansion and contraction.

**300-8. Installation of Conductors with Other Systems.** No electric conductor shall be installed in any raceway, cable, or cable tray that contains a pipe, tube, or equal for steam, water, air, gas, drainage, or any service other than electrical.

*Exception: Cables approved for the purpose.*

**300-9. Grounding Metal Enclosures.** Metal raceways, boxes, cabinets, cable armor, and fittings shall be grounded as required in Article 250.

**300-10. Electrical Continuity of Metal Raceways and Enclosures.** Metal raceways, cable armor, and other metal enclosures for conductors shall be metallically joined together into a continuous electric conductor, and shall be so connected to all boxes, fittings, and cabinets as to provide effective electrical continuity. Raceways and cable assemblies shall be mechanically secured to boxes, fittings, cabinets, and other enclosures, except as provided for nonmetallic boxes in Section 370-7(c).

**300-11. Securing and Supporting.**

(a) **Secured in Place.** Raceways, cable assemblies, boxes, cabinets, and fittings shall be securely fastened in place. Support wires that do not provide rigid support shall not be permitted as the sole support.

*Exception: As permitted elsewhere in this Code.*

(b) **Raceways Used as Means of Support.** Raceways shall not be used as a means of support for other raceways, cables, or nonelectric equipment.

*Exception No. 1: Where the raceways or means of support are identified for the purpose.*

(FPN): See Article 318 for cable trays.

*Exception No. 2: Raceways containing power supply conductors for electrically controlled equipment shall be permitted to support Class 2 circuit conductors or cables that are solely for the purpose of connection to the equipment control circuits.*

*Exception No. 3: As permitted in Sections 370-13 for boxes or conduit bodies, or 410-16(f) for fixtures.*

**300-12. Mechanical Continuity — Raceways and Cables.** Metal or nonmetallic raceways, cable armors, and cable sheaths shall be continuous between cabinets, boxes, fittings, or other enclosures or outlets.

**300-13. Mechanical and Electrical Continuity — Conductors.**

(a) **General.** Conductors shall be continuous between outlets, devices, etc., and there shall be no splice or tap within a raceway itself.

*Exception No. 1: As provided in Section 374-8 for auxiliary gutters.*

*Exception No. 2: As provided in Section 362-6 for wireways.*

*Exception No. 3: As provided in Section 300-15(a), Exception No. 1 for boxes or fittings.*

*Exception No. 4: As provided in Section 352-7 for surface metal raceways.*

(b) **Device Removal.** In multiwire circuits the continuity of a grounded conductor shall not be dependent upon device connections, such as

lampholders, receptacles, etc., where the removal of such devices would interrupt the continuity.

**300-14. Length of Free Conductors at Outlets, Junctions, and Switch Points.** At least 6 inches (152 mm) of free conductor shall be left at each outlet, junction, and switch point for splices or the connection of fixtures or devices.

*Exception: Conductors that are not spliced or terminated at the outlet, junction, or switch point.*

**300-15. Boxes or Fittings — Where Required.**

(a) **Box or Fitting.** A box or fitting shall be installed at each conductor splice connection point, outlet, switch point, junction point, or pull point for the connection of conduit, electrical metallic tubing, surface raceway, or other raceways.

*Exception No. 1: A box or fitting shall not be required for a conductor splice connection in surface raceways, wireways, header-ducts, multi-outlet assemblies, auxiliary gutters, cable trays, and conduit bodies having removable covers which are accessible after installation.*

*Exception No. 2: As permitted in Section 410-31 where a fixture is used as a raceway.*

(b) **Box Only.** A box shall be installed at each conductor splice connection point, outlet, switch point, junction point, or pull point for the connection of Type AC cable, Type MC cable, mineral-insulated, metal-sheathed cable, nonmetallic-sheathed cable, or other cables, at the connection point between any such cable system and a raceway system and at each outlet and switch point for concealed knob-and-tube wiring.

*Exception No. 1: As permitted by Section 336-16 for insulated outlet devices supplied by nonmetallic-sheathed cable.*

*Exception No. 2: As permitted by Section 410-62 for rosettes.*

*Exception No. 3: Where accessible fittings are used for straight-through splices in mineral-insulated, metal-sheathed cable.*

*Exception No. 4: Where cables enter or exit from conduit or tubing which is used to provide cable support or protection against physical damage. A fitting shall be provided on the end(s) of the conduit or tubing, to protect the wires or cables from abrasion.*

*Exception No. 5: A wiring device with integral enclosure identified for the use having brackets that securely fasten the device to walls or ceilings of conventional on-site frame construction for use with nonmetallic-sheathed cable shall be permitted without a separate box.*

(FPN): See Sections 336-15, Exception No. 2; 545-10; 550-8(j); and 551-14(e), Exception No. 1.

*Exception No. 6: Where metallic manufactured wiring systems are used.*

*Exception No. 7: A conduit body shall be permitted in lieu of a box where installed to comply with Section 370-6(c) and Section 370-18.*

*Exception No. 8: Where a device identified and listed as suitable for installation without a box is used with a closed-loop power distribution system.*

*Exception No. 9: A fitting identified for the use shall be permitted in lieu of a box where accessible after installation and where the conductors are not spliced or terminated.*

### **300-16. Raceway or Cable to Open or Concealed Wiring.**

(a) **Box or Fitting.** A box or terminal fitting having a separately bushed hole for each conductor shall be used wherever a change is made from conduit, electrical metallic tubing, nonmetallic-sheathed cable, Type AC cable, Type MC cable, or mineral-insulated, metal-sheathed cable and surface raceway wiring to open wiring or to concealed knob-and-tube wiring. A fitting used for this purpose shall contain no taps or splices and shall not be used at fixture outlets.

(b) **Bushing.** A bushing shall be permitted in lieu of a box or terminal fitting at the end of a conduit or electrical metallic tubing where the raceway terminates behind an open (unenclosed) switchboard or at an unenclosed control and similar equipment. The bushing shall be of the insulating type for other than lead-sheathed conductors.

**300-17. Number and Size of Conductors in Raceway.** The number and size of conductors in any raceway shall not be more than will permit dissipation of the heat and ready installation or withdrawal of the conductors without damage to the conductors or to their insulation.

(FPN): See the following sections of this Code: electrical nonmetallic tubing, 331-6; conduit, 345-7 and 346-6; electrical metallic tubing, 348-6; rigid nonmetallic conduit, 347-11; flexible metallic tubing, 349-12; flexible metal conduit, 350-3; liquidtight flexible metal conduit, 351-6; liquidtight nonmetallic flexible conduit, 351-25; surface raceways, 352-4 and 352-25; underfloor raceways, 354-5; cellular metal floor raceways, 356-5; cellular concrete floor raceways, 358-11; wireways, 362-5; auxiliary gutters, 374-5; fixture wire, 402-7; theaters, 520-5; signs, 600-21 (d); elevators, 620-33; sound recording, 640-3 and 640-4; Class 1, Class 2, and Class 3 circuits, Article 725; fire protective signaling circuits, Article 760, and optical fiber cables, Article 770.

### **300-19. Supporting Conductors in Vertical Raceways.**

(a) **Spacing Intervals — Maximum.** Conductors in vertical raceways shall be supported. One cable support shall be provided at the top of the vertical raceway or as close to the top as practical, plus a support for each additional interval of spacing as specified in Table 300-19(a).

*Exception No. 1: If the total vertical riser is less than 25 percent of the spacing specified in Table 300-19(a), no cable support shall be required.*

*Exception No. 2: Steel wire armor cable shall be supported at the top of the riser with a cable support that clamps the steel wire armor. A safety device shall be permitted at the lower end of the riser to hold the cable in the event there is slippage of the cable in the wire armored cable support. Additional wedge-type supports shall be permitted to relieve the strain on the equipment terminals caused by expansion of the cable under load.*

(b) **Support Methods.** One of the following methods of support shall be used:

(1) By clamping devices constructed of or employing insulating wedges inserted in the ends of the conduits. Where clamping of insulation does not adequately support the cable, the conductor also shall be clamped.

(2) By inserting boxes at the required intervals in which insulating supports are installed and secured in a satisfactory manner to withstand the weight of the conductors attached thereto, the boxes being provided with covers.

(3) In junction boxes, by deflecting the cables not less than 90 degrees and carrying them horizontally to a distance not less than twice the diameter of the cable, the cables being carried on two or more insulating supports, and additionally secured thereto by tie wires if desired. When this method is used, cables shall be supported at intervals not greater than 20 percent of those mentioned in the preceding tabulation.

(4) By a method of equal effectiveness.

**Table 300-19(a). Spacings for Conductor Supports**

AWG or Circular-Mil Size of Wire	Conductors			Aluminum or Copper-Clad Aluminum	Copper
	Support of Conductors in Vertical Raceways				
18 AWG thru 8 AWG	Not greater than	100 feet	100 feet	100 feet	100 feet
6 AWG thru 0 AWG	" " "	200 feet	100 feet	100 feet	100 feet
2/0 AWG thru 4/0 AWG	" " "	180 feet	80 feet	80 feet	80 feet
over 4/0 AWG thru 350 MCM	" " "	135 feet	60 feet	60 feet	60 feet
over 350 MCM thru 500 MCM	" " "	120 feet	50 feet	50 feet	50 feet
over 500 MCM thru 750 MCM	" " "	95 feet	40 feet	40 feet	40 feet
over 750 MCM	" " "	85 feet	35 feet	35 feet	35 feet

For SI units: one foot = 0.3048 meter.

### 300-20. Induced Currents in Metal Enclosures or Metal Raceways.

(a) **Conductors Grouped Together.** Where conductors carrying alternating current are installed in metal enclosures or metal raceways, they shall be so arranged as to avoid heating the surrounding metal by induction. To accomplish this, all phase conductors and, where used, the neutral and all equipment grounding conductors shall be grouped together.

*Exception No. 1: As permitted in Section 250-50, Exception for equipment grounding connections.*

*Exception No. 2: As permitted in Section 427-47 for skin effect heating.*

(b) **Individual Conductors.** Where a single conductor carrying alternating current passes through metal with magnetic properties the inductive effect shall be minimized by: (1) cutting slots in the metal between the individual holes through which the individual conductors pass, or (2) passing all the conductors in the circuit through an insulating wall sufficiently large for all of the conductors of the circuit.

*Exception: In the case of circuits supplying vacuum or electric-discharge lighting systems or signs, or X-ray apparatus, the currents carried by the conductors are so small that the inductive heating effect can be ignored where these conductors are placed in metal enclosures or pass through metal.*

(FPN): Because aluminum is not a magnetic metal, there will be no heating due to hysteresis; however, induced currents will be present. They will not be of



sufficient magnitude to require grouping of conductors or special treatment in passing conductors through aluminum wall sections.

**300-21. Spread of Fire or Products of Combustion.** Electrical installations in hollow spaces, vertical shafts, and ventilation or air-handling ducts shall be so made that the possible spread of fire or products of combustion will not be substantially increased. Openings around electrical penetrations through fire-resistance rated walls, partitions, floors, or ceilings shall be firestopped using approved methods to maintain the fire-resistance rating.

**300-22. Wiring in Ducts, Plenums, and Other Air-Handling Spaces.** The provisions of this section apply to the installation and uses of electric wiring and equipment in ducts, plenums, and other air-handling spaces.

(FPN): See Article 424, Part F for Electric Duct Heaters.

**(a) Ducts for Dust, Loose Stock, or Vapor Removal.** No wiring systems of any type shall be installed in ducts used to transport dust, loose stock, or flammable vapors. No wiring system of any type shall be installed in any duct, or shaft containing only such ducts, used for vapor removal or for ventilation of commercial-type cooking equipment.

**(b) Ducts or Plenums Used for Environmental Air.** Only wiring methods consisting of Type MI cable, Type MC cable employing a smooth or corrugated impervious metal sheath without an overall nonmetallic covering, electrical metallic tubing, flexible metallic tubing, intermediate metal conduit, or rigid metal conduit shall be installed in ducts or plenums used for environmental air. Flexible metal conduit and liquidtight flexible metal conduit shall be permitted, in lengths not to exceed 4 feet (1.22 m), to connect physically adjustable equipment and devices permitted to be in these ducts and plenum chambers. The connectors used with flexible metal conduit shall effectively close any openings in the connection. Equipment and devices shall be permitted within such ducts or plenum chambers only if necessary for their direct action upon, or sensing of, the contained air. Where equipment or devices are installed and illumination is necessary to facilitate maintenance and repair, enclosed gasketed-type fixtures shall be permitted.

(FPN): The above applies to ducts and plenums specifically fabricated to transport environmental air.

**(c) Other Space Used for Environmental Air.** Only wiring methods consisting of Type MI cable, Type MC cable without an overall nonmetallic covering, Type AC cable, or other factory-assembled multiconductor control or power cable which is specifically listed for the use shall be installed in other space used for environmental air.

Other type cables and conductors shall be installed in electrical metallic tubing, flexible metallic tubing, intermediate metal conduit, rigid metal conduit, flexible metal conduit, or where accessible, wireway with metal covers or solid bottom metal cable tray with solid metal covers.

Electric equipment with a metal enclosure or with a nonmetallic enclosure listed for the use and having adequate fire-resistant and low-smoke-producing characteristics, and associated wiring material suitable for the ambient temperature shall be permitted to be installed in other space used for environmental air unless prohibited elsewhere in this Code.

(FPN): The above applies to other spaces such as spaces over hung ceilings which are used for environmental air-handling purposes.

*Exception No. 1: Liquidtight flexible metal conduit in single lengths not exceeding 6 feet (1.83 m).*

*Exception No. 2: Integral fan systems specifically identified for such use.*

*Exception No. 3: This section does not include habitable rooms or areas of buildings, the prime purpose of which is not air handling.*

*Exception No. 4: Listed prefabricated cable assemblies of metallic manufactured wiring systems without nonmetallic sheath shall be permitted where listed for this use.*

*Exception No. 5: This section does not include the joist or stud spaces in dwelling units when wiring or equipment passes through such spaces perpendicular to the long dimension of such spaces.*

*Exception No. 6: This section does not include the underfloor area specified in Section 645-2(c)(3).*

**(d) Data Processing Systems.** Electric wiring in air-handling areas beneath raised floors for data processing systems shall comply with Article 645.

## **B. Requirements for Over 600 Volts, Nominal**

**300-31. Covers Required.** Suitable covers shall be installed on all boxes, fittings, and similar enclosures to prevent accidental contact with energized parts or physical damage to parts or insulation.

**300-32. Conductors of Different Systems.** Conductors of high-voltage and low-voltage systems shall not occupy the same wiring enclosure or pull and junction boxes.

*Exception No. 1: In motors, switchgear and control assemblies and similar equipment.*

*Exception No. 2: In manholes, if low-voltage conductors are separated from high-voltage conductors.*

**300-34. Conductor Bending Radius.** The conductor shall not be bent to a radius less than eight times the overall diameter for nonshielded conductors or twelve times the diameter for shielded or lead-covered conductors during or after installation.

**300-35. Protection Against Induction Heating.** Metallic raceways and associated conductors shall be so arranged as to avoid heating of the raceway by induction.

**300-36. Grounding.** Wiring and equipment installations shall be grounded in accordance with the applicable provisions of Article 250.

## **ARTICLE 305 — TEMPORARY WIRING**

**305-1. Scope.** The provisions of this article apply to temporary electrical power and lighting wiring methods which may be of a class less than would be required for a permanent installation.

**305-2. Other Articles.** Except as specifically modified in this article, all other requirements of this Code for permanent wiring shall apply to temporary wiring installations.

**305-3. Time Constraints.**

(a) **During the Period of Construction.** Temporary electrical power and lighting installations shall be permitted during the period of construction, remodeling, maintenance, repair, or demolition of buildings, structures, equipment, or similar activities.

(b) **90 Days.** Temporary electrical power and lighting installations shall be permitted for a period not to exceed 90 days for Christmas decorative lighting, carnivals, and similar purposes.

(c) **Emergencies and Tests.** Temporary electrical power and lighting installations shall be permitted during emergencies and for tests, experiments, and developmental work.

(d) **Removal.** Temporary wiring shall be removed immediately upon completion of construction or purpose for which the wiring was installed.

**305-4. General.**

(a) **Services.** Services shall be installed in conformance with Article 230.

(b) **Feeders.** Feeders shall be protected as provided in Article 240. They shall originate in an approved distribution center. The conductors shall be permitted within flexible multiconductor cord or cable assemblies of a type identified in Table 400-4 for hard usage or extra hard usage. Where the voltage does not exceed 150 volts to ground and where not subject to physical damage, feeders shall be permitted to be run as open conductors if supported on insulators at intervals of not more than 10 feet (3.05 m).

*Exception: Where installed for the purposes specified in Section 305-3(c).*

(c) **Branch Circuits.** All branch circuits shall originate in an approved power outlet or panelboard. Conductors shall be permitted within flexible multiconductor cord or cable assemblies of a type identified in Table 400-4 for hard usage or extra hard usage. All conductors shall be protected as provided in Article 240. Where the voltage does not exceed 150 volts to ground and where not subject to physical damage, branch circuits shall be permitted to be run as open conductors if supported on insulators at intervals of not more than 10 feet (3.05 m). No open wiring branch circuit conductors shall be laid on the floor or ground.

*Exception: Where installed for the purposes specified in Section 305-3(c).*

(d) **Receptacles.** All receptacles shall be of the grounding type. Unless installed in a continuous grounded metal raceway or metal-covered cable all branch circuits shall contain a separate equipment grounding conductor and all receptacles shall be electrically connected to the equipment grounding conductors. Receptacles on construction sites shall not be installed on branch circuits which supply temporary lighting. Receptacles shall not be connected to the same ungrounded conductor of multiwire circuits which supply temporary lighting.

(e) **Disconnecting Means.** Suitable disconnecting switches or plug connectors shall be installed to permit the disconnection of all ungrounded conductors of each temporary circuit. Multiwire branch circuits shall be provided with a means to disconnect simultaneously all ungrounded conduc-

tors at the power outlet or panelboard where the branch circuit originated. Approved handle ties shall be permitted.

(f) **Lamp Protection.** All lamps for general illumination shall be protected from accidental contact or breakage by a suitable fixture or lampholder with a guard.

Brass shell, paper-lined sockets, or other metal-cased sockets shall not be used unless the shell is grounded.

(g) **Splices.** On construction sites a box shall not be required for splices or junction connections where the circuit conductors are multiconductor cord or cable assemblies or open conductors. See Sections 110-14(b) and 400-9. A box shall be used wherever a change is made to a raceway system or a cable system which is metal clad or metal-sheathed.

(h) **Protection from Accidental Damage.** Flexible cords and cables shall be protected from accidental damage. Sharp corners and projections shall be avoided. When passing through doorways or other pinch points, protection shall be provided to avoid damage.

**305-5. Grounding.** All grounding shall conform with Article 250.

**305-6. Ground-Fault Protection for Personnel.** Ground-fault protection for personnel on construction sites shall be provided to comply with (a) or (b) below.

(a) **Ground-Fault Circuit-Interrupters.** All 125-volt, single-phase, 15- and 20-ampere receptacle outlets which are not a part of the permanent wiring of the building or structure and which are in use by employees shall have ground-fault circuit-interrupter protection for personnel.

*Exception: Receptacles on a 2-wire, single-phase portable or vehicle-mounted generator rated not more than 5 kW, where the circuit conductors of the generator are insulated from the generator frame and all other grounded surfaces.*

(b) **Assured Equipment Grounding Conductor Program.** A written procedure shall be continuously enforced at the construction site by one or more designated persons to assure that equipment grounding conductors for all cord sets, receptacles which are not a part of the permanent wiring of the building or structure and equipment connected by cord and plug are installed and maintained in accordance with the applicable requirements of Sections 210-7(c), 250-45, 250-59, and 305-4(d).

(1) The following tests shall be performed on all cord sets, receptacles which are not part of the permanent wiring of the building or structure, and cord- and plug-connected equipment required to be grounded.

a. All equipment grounding conductors shall be tested for continuity and shall be electrically continuous.

b. Each receptacle and attachment plug shall be tested for correct attachment of the equipment grounding conductor. The equipment grounding conductor shall be connected to its proper terminal.

c. All required tests shall be performed:

1. Before first use on the construction site.

2. When there is evidence of damage.

3. Before equipment is returned to service following any repairs.

4. At intervals not exceeding 3 months.

(2) The tests required in (1) above shall be recorded and made available to the authority having jurisdiction.

**305-7. Guarding.** For temporary wiring over 600 volts, nominal, suitable fencing, barriers, or other effective means shall be provided to prevent access of other than authorized and qualified personnel.

## ARTICLE 310 — CONDUCTORS FOR GENERAL WIRING

**310-1. Scope.** This article covers general requirements for conductors and their type designations, insulations, markings, mechanical strengths, ampacity ratings, and uses. These requirements do not apply to conductors that form an integral part of equipment, such as motors, motor controllers, and similar equipment, or to conductors specifically provided for elsewhere in this Code.

(FPN): For flexible cords and cables, see Article 400. For fixture wires, see Article 402.

### 310-2. Conductors.

(a) **Insulated.** Conductors shall be insulated.

*Exception: Where covered or bare conductors are specifically permitted elsewhere in this Code.*

(FPN): See Section 250-152 for insulation of neutral conductors of a solidly grounded high-voltage system.

(b) **Conductor Material.** Conductors in this article shall be of aluminum, copper-clad aluminum, or copper unless otherwise specified.

**310-3. Stranded Conductors.** Where installed in raceways, conductors of size No. 8 and larger shall be stranded.

*Exception No. 1: When used as busbars or in mineral-insulated, metal-sheathed cable.*

*Exception No. 2: Bonding conductors as required in Section 680-22(b).*

**310-4. Conductors in Parallel.** Aluminum, copper-clad aluminum, or copper conductors of size 1/0 and larger, comprising each phase or neutral, shall be permitted to be connected in parallel (electrically joined at both ends to form a single conductor).

*Exception No. 1: As permitted in Section 620-12(a)(1), Exception.*

*Exception No. 2: Conductors in sizes smaller than No. 1/0 AWG shall be permitted to be run in parallel to supply control power to indicating instruments, contactors, relays, solenoids, and similar control devices provided: (a) they are contained within the same raceway or cable; (b) the ampacity of each individual conductor is sufficient to carry the entire load current shared by the parallel conductors; and (c) the overcurrent protection is such that the ampacity of each individual conductor will not be exceeded if one or more of the parallel conductors become inadvertently disconnected.*

*Exception No. 3: Conductors in sizes smaller than 1/0 shall be permitted to be run in parallel for frequencies of 360 hertz and higher when all of the conditions of Exception No. 2(a), (b), and (c) are met:*

The paralleled conductors in each phase or neutral shall:

- (1) Be the same length;
- (2) Have the same conductor material;
- (3) Be the same size in circular mil area;
- (4) Have the same insulation type;
- (5) Be terminated in the same manner.

Where run in separate raceways or cables the raceways or cables shall have the same physical characteristics.

(FPN): Differences in inductive reactance and unequal division of current can be minimized by choice of materials, methods of construction and orientation of conductors. It is not the intent to require that conductors of one phase or neutral be the same as those of another phase or neutral to achieve balance.

When equipment grounding conductors are used with conductors in parallel, they shall comply with the requirements of this section except that they shall be sized as per Section 250-95.

When conductors are used in parallel, space in enclosures shall be given consideration (see Articles 370 and 373).

Conductors installed in parallel shall comply with the provisions of Note 8 to Tables 310-16 through 310-31.

**310-5. Minimum Size of Conductors.** The minimum size of conductors shall be as given in Table 310-5.

**Table 310-5**

Voltage Rating of Conductor—Volts	Minimum Conductor Size—AWG
0 thru 2000	14 Copper 12 Aluminum or Copper-Clad Aluminum
2001 thru 5000	8
5001 thru 8000	6
8001 thru 15000	2-100% Insulation Level* 1-133% Insulation Level*
15001 thru 28000	1
28001 thru 35000	1/0

\* See Table 310-64, Definitions.

*Exception No. 1: For flexible cords as permitted by Section 400-12.*

*Exception No. 2: For fixture wire as permitted by Section 410-24.*

*Exception No. 3: For fractional horsepower motors as permitted by Section 430-22.*

*Exception No. 4: For cranes and hoists as permitted by Section 610-14.*

*Exception No. 5: For elevator control and signaling circuits as permitted by Section 620-12.*

*Exception No. 6: For Class 1, Class 2, and Class 3 circuits as permitted by Sections 725-16, 725-37, and 725-40.*

*Exception No. 7: For fire protective signaling circuits as permitted by Sections 760-16, 760-27, and 760-30.*

*Exception No. 8: For 2001-5000 volt for Types AVA, AVB, and AVL cables, the minimum conductor size is No. 14 AWG copper or No. 12 AWG aluminum or copper-clad aluminum.*

*Exception No. 9: For Type V cables, the minimum conductor sizes are: No. 12 AWG for 2000-volt rating, No. 10 AWG for 3000-volt rating, and No. 8 AWG for 4000-volt rating.*

*Exception No. 10: For motor control circuits as permitted by Section 430-72.*

**310-6. Shielding.** Solid dielectric insulated conductors operated above 2000 volts in permanent installations shall have ozone-resistant insulation and shall be shielded. All metallic insulation shields shall be grounded through an effective grounding path meeting the requirements of Section 250-51. Shielding shall be for the purpose of confining the voltage stresses to the insulation.

*Exception: Nonshielded insulated conductors listed by a qualified testing laboratory shall be permitted for use up to 8000 volts under the following conditions:*

*a. Conductors shall have insulation resistant to electric discharge and surface tracking, or the insulated conductor(s) shall be covered with a material resistant to ozone, electric discharge, and surface tracking.*

*b. Where used in wet locations the insulated conductor(s) shall have an overall nonmetallic jacket or a continuous metallic sheath.*

*c. Where operated at 5001 to 8000 volts, the insulated conductor(s) shall have a nonmetallic jacket over the insulation. The insulation shall have a specific inductive capacity no greater than 3.6 and the jacket shall have a specific inductive capacity no greater than 10 and no less than 6.*

*d. Insulation and jacket thicknesses shall be in accordance with Table 310-63.*

**310-7. Direct Burial Conductors.** Cables rated above 2000 volts shall be shielded. Conductors used for direct burial applications shall be of a type identified for such use.

*Exception: Nonshielded multiconductor cables rated 2001-5000 volts shall be permitted if the cable has an overall metallic sheath or armor.*

The metallic shield, sheath or armor shall be grounded through an effective grounding path meeting the requirements of Section 250-51.

(FPN): See Sections 300-5 and 710-3(b).

### **310-8. Wet Locations.**

**(a) Insulated Conductors.** Insulated conductors used in wet locations shall be (1) lead-covered; (2) Types RHW, TW, THW, THWN, XHHW; or (3) of a type listed for use in wet locations.

**(b) Cables.** Cables of one or more conductors used in wet locations shall be of a type listed for use in wet locations.

Conductors used for direct burial applications shall be of a type listed for such use.

**310-9. Corrosive Conditions.** Conductors exposed to oils, greases, vapors, gases, fumes, liquids, or other substances having a deleterious effect upon the conductor or insulation shall be of a type suitable for the application.

**310-10. Temperature Limitation of Conductors.** No conductor shall be used in such a manner that its operating temperature will exceed that designated for the type of insulated conductor involved. In no case shall conductors be associated together in such a way with respect to type of circuit, the wiring method employed, or the number of conductors that the limiting temperature of any conductor is exceeded.

(FPN): The temperature rating of a conductor (see Tables 310-13 and 310-61) is the maximum temperature, at any location along its length, that the conductor can withstand over a prolonged time period without serious degradation. Tables 310-16 through 310-31 and 310-69 through 310-84, the correction factors at the bottom of these tables, and the notes to the tables provide guidance for coordinating conductor sizes, types, ampacities, ambient temperatures, and number of associated conductors.

The principal determinants of operating temperature are:

1. Ambient temperature. Ambient temperature may vary along the conductor length as well as from time to time.

2. Heat generated internally in the conductor as the result of load current flow.

3. The rate at which generated heat dissipates into the ambient medium. Thermal insulation which covers or surrounds conductors will affect the rate of heat dissipation.

4. Adjacent load-carrying conductors. Adjacent conductors have the dual effect of raising the ambient temperature and impeding heat dissipation.

### **310-11. Marking.**

(a) **Required Information.** All conductors and cables shall be marked to indicate the following information, using the applicable method described in (b) below.

(1) The maximum rated voltage for which the conductor was listed.

(2) The proper type letter or letters for the type of wire or cable as specified elsewhere in this article, in Tables 310-13 and 310-61, and in Articles 336, 337, 338, 339, 340, and Section 725-40(b)(3).

(3) The manufacturer's name, trademark, or other distinctive marking by which the organization responsible for the product can be readily identified.

(4) The AWG size or circular-mil area.

#### **(b) Method of Marking.**

(1) **Surface Marking.** The following conductors and cables shall be durably marked on the surface at intervals not exceeding 24 inches (610 mm):

a. Single- and multiconductor rubber- and thermoplastic- insulated wire and cable.

b. Nonmetallic-sheathed cable.

c. Service-entrance cable.

d. Underground feeder and branch-circuit cable.



- e. Tray cable.
- f. Irrigation cable.
- g. Power-limited tray cable.

(2) **Marker Tape.** Metal-covered multiconductor cables shall employ a marker tape located within the cable and running for its complete length.

*Exception No. 1: Mineral-insulated, metal-sheathed cable.*

*Exception No. 2: Type AC cable.*

*Exception No. 3: The information required in Section 310-11(a)(1), (2), and (4) above shall be permitted to be durably marked on the outer nonmetallic covering of Type MC or Type PLTC cables at intervals not exceeding 24 inches (610 mm).*

*Exception No. 4: The information required in Section 310-11(a) shall be permitted to be durably marked on a nonmetallic covering under the metallic sheath of Type PLTC cable at intervals not exceeding 24 inches (610 mm).*

(FPN): Included in the group of metal-covered cables are: Type AC cable (Article 333), Type MC cable (Article 334) and lead-sheathed cable.

(3) **Tag Marking.** The following conductors and cables shall be marked by means of a printed tag attached to the coil, reel, or carton:

- a. Mineral-insulated, metal-sheathed cable.
- b. Switchboard wires.
- c. Metal-covered, single-conductor cables.
- d. Conductors having outer surface of asbestos.
- e. Type AC cable.

(4) **Optional Marking of Wire Size.** For the following multiconductor cables, the information required in (a) (4) above shall be permitted to be marked on the surface of the individual insulated conductors:

- a. Type MC cable.
- b. Tray cable.
- c. Irrigation cable.
- d. Power-limited tray cable.

(c) **Suffixes to Designate Number of Conductors.** A type letter or letters used alone shall indicate a single insulated conductor. The following letter suffixes shall indicate the following:

D—for two insulated conductors laid parallel within an outer nonmetallic covering.

M—for an assembly of two or more insulated conductors twisted spirally within an outer nonmetallic covering.

### 310-12. Conductor Identification.

(a) **Grounded Conductors.** Insulated conductors of No. 6 or smaller, intended for use as grounded conductors of circuits, shall have an outer identification of a white or natural gray color. Multiconductor flat cable No. 4 or larger shall be permitted to employ an external ridge on the grounded conductor.

*Exception No. 1: Multiconductor varnished-cloth-insulated cables.*

*Exception No. 2: Fixture wires as outlined in Article 402.*

*Exception No. 3: Mineral-insulated, metal-sheathed cable.*

*Exception No. 4: A conductor identified as required by Section 210-5(a) for branch circuits.*

*Exception No. 5: Where the conditions of maintenance and supervision assure that only qualified persons will service the installation, grounded conductors in multiconductor cables shall be permitted to be permanently identified at their terminations at the time of installation by a distinctive white marking or other equally effective means.*

For aerial cable the identification shall be as above, or by means of a ridge so located on the exterior of the cable as to identify it.

Wires having their outer covering finished to show a white or natural gray color but having colored tracer threads in the braid, identifying the source of manufacture, shall be considered as meeting the provisions of this section.

(FPN): For identification requirements for conductors larger than No. 6, see Section 200-6.

**(b) Equipment Grounding Conductors.** Bare, covered or insulated grounding conductors shall be permitted. Individually covered or insulated grounding conductors shall have a continuous outer finish that is either green, or green with one or more yellow stripes.

*Exception No. 1: An insulated or covered conductor larger than No. 6 shall, at the time of installation, be permitted to be permanently identified as a grounding conductor at each end and at every point where the conductor is accessible. Identification shall be accomplished by one of the following means:*

- a. Stripping the insulation or covering from the entire exposed length;*
- b. Coloring the exposed insulation or covering green; or*
- c. Marking the exposed insulation or covering with green colored tape or green colored adhesive labels.*

*Exception No. 2: Where the conditions of maintenance and supervision assure that only qualified persons will service the installation, an insulated conductor in a multiconductor cable shall, at the time of installation, be permitted to be permanently identified as a grounding conductor at each end and at every point where the conductor is accessible by one of the following means:*

- a. Stripping the insulation from the entire exposed length;*
- b. Coloring the exposed insulation green; or*
- c. Marking the exposed insulation with green tape or green colored adhesive labels.*

**(c) Ungrounded Conductors.** Conductors which are intended for use as ungrounded conductors, whether used as single conductors or in multiconductor cables, shall be finished to be clearly distinguishable from grounded and grounding conductors. Ungrounded conductors shall be distinguished by colors other than white, natural gray, or green; or by a combination of color plus distinguishing marking. Distinguishing markings shall also be in a color other than white, natural gray, or green, and shall consist of a stripe or stripes or a regularly spaced series of identical marks. Distinguishing markings shall not conflict in any manner with the surface markings required by Section 310-11(b)(1).

**310-13. Conductor Constructions and Applications.** Insulated conductors shall comply with the applicable provisions of one or more of the following:

Tables 310-13, 310-61, 310-62, 310-63, 310-64, 310-65, 310-66, and 310-67.

These conductors shall be permitted for use in any of the wiring methods recognized in Chapter 3 and as specified in their respective tables.

(FPN): Thermoplastic insulation may stiffen at temperatures colder than minus 10°C (plus 14°F), requiring care be exercised during installation at such temperatures. Thermoplastic insulation may also be deformed at normal temperatures where subjected to pressure, requiring care be exercised during installation and at points of support.

**310-14. Aluminum Conductor Material.** Solid aluminum conductors No. 8, 10, and 12 AWG shall be made of an AA-8000 series electrical grade aluminum alloy conductor material. Stranded aluminum conductors No. 8 AWG through 1000 MCM marked as Type XHHW, THW, THWN, THHN, service entrance Type SE Style U and SE Style R shall be made of an AA-8000 series electrical grade aluminum alloy conductor material.

**310-15. Ampacity.** The term electrical duct(s) as used in Article 310 shall include any of the electrical conduits recognized in Chapter 3 as suitable for use underground; and other raceways, round in cross section, listed for underground use; embedded in earth or concrete:

(a) **Applications Covered by Tables.** Ampacities for conductors rated 0 through 2000 volts shall be as specified in Tables 310-16 through 310-31 and their accompanying notes. The ampacity for Types V, AVA, AVB, and AVL conductors rated 2001 through 5000 volts shall be the same as for those conductor types rated 0 through 2000 volts. The ampacities for solid dielectric insulated conductors rated 2001 through 35000 volts shall be as specified in Tables 310-69 through 310-84 and their accompanying notes.

(b) **Applications Not Covered by Tables.** Ampacities not covered by the tables shall be permitted to be calculated under engineering supervision, by means of the following general formula:

$$I = \sqrt{\frac{TC - (TA + \text{DELTA TD})}{\text{RDC} (1 + \text{YC}) \text{RCA}}}$$

TC = Conductor temperature in degrees C

TA = Ambient temperature in degrees C

DELTA TD = Dielectric loss temperature rise

RDC = DC resistance of conductor at temperature TC

YC = Component ac resistance resulting from skin effect and proximity effect

RCA = Effective thermal resistance between conductor and surrounding ambient.

(FPN): The ampacities provided by this section are based on temperature alone and do not take voltage drop into consideration.

(FPN): Conductors of circuits as defined in Article 100, sized to prevent a voltage drop exceeding 5 percent, will provide reasonable efficiency of operation.

(c) **Selection of Ampacity.** When more than one calculated or tabulated ampacity could apply for a given circuit length, the lowest value shall be used.

Table 310-13. Conductor Application and Insulations

Trade Name	Type Letter	Max. Operating Temp.	Application Provisions	Insulation	AWG or MCM	Thickness of Insulation	Mils	Outer Covering
Asbestos	A	200°C 392°F	Dry locations only. Only for leads within apparatus or within raceways connected to apparatus. Limited to 300 volts.	Asbestos	14 12-8	..... .....	30 40	Without asbestos braid
Asbestos	AA	200°C 392°F	Dry locations only. Only for leads within apparatus or within raceways connected to apparatus or as open wiring. Limited to 300 volts.	Asbestos	14 12-8 6-2 1-4/0	..... ..... ..... .....	30 30 40 60	With asbestos, glass, or other suitable braid material
Asbestos	AI	125°C 257°F	Dry locations only. Only for leads within apparatus or within raceways connected to apparatus. Limited to 300 volts.	Impregnated Asbestos	14 12-8	..... .....	30 40	Without asbestos braid
Asbestos	AIA	125°C 257°F	Dry locations only. Only for leads within apparatus or within raceways connected to apparatus or as open wiring.	Impregnated Asbestos	14 12-8 6-2 1-4/0 213-500 501-1000	..... ..... ..... ..... ..... .....	Sol. Str. 30 30 30 40 40 60 60 75 90 105	With asbestos, glass, or other suitable braid material

Table 310-13. (Continued)

Asbestos and Varnished Cambric	AVA	110°C 230°F	Dry locations only.	Impregnated Asbestos and Varnished Cambric	AVA AVL				AVA-asbestos, glass, or other suitable braid material	
					1st Asb.	VC	2nd Asb.	2nd Asb.		
					14-8 (solid only) ..	—	30	20	25	
					14-8 ...	10	30	15	25	
					6-2 ....	15	30	20	25	
					1-4/0 ..	20	30	30	30	
					213-500	25	40	40	40	
					501-1000	30	40	40	40	
					1001-2000	30	50	50	50	
					For 1000-5000 volts, see Table 310-67.					
Asbestos and Varnished Cambric	AVB	90°C 194°F	Dry locations only.	Impregnated Asbestos and Varnished Cambric	VC Asb.				Flame-retardant, cotton braid (switchboard wiring)	
					18-8 .....		30	20		
					6-2 .....		40	30		
					1-4/0 .....		40	40		
								2nd Asb.	Flame-retardant, cotton braid	
					14-8 .....	10	30	15		
					6-2 .....	15	30	20		
					1-4/0 .....	20	30	30		
					213-500	25	40	40		
					501-1000	30	40	40		
					1001-2000	30	50	50		
					For 1000-5000 volts, see Table 310-67.					

Table 310-13 (Continued)

Trade Name	Type Letter	Max. Operating Temp.	Application Provisions	Insulation	AWG or MCM	Thickness of Insulation		Outer Covering								
						Mils	Mils									
Asbestos and Varnished Cambric	AVL	110°C 230°F	Dry and wet locations.	Impregnated Asbestos and Varnished Cambric	14-8 (solid only) 14-8 6-2 1-4/0 213-500 501-1000 1001-2000	1st Asb. VC	AVA	AVL	AVL-lead sheath							
							2nd Asb.	2nd Asb.								
							20	25								
							15	25								
							20	25								
							30	30								
							40	40								
							50	50								
							For 1000-5000 volts, see Table 310-67.									
							Fluorinated Ethylene Propylene	FEP or FEPB		90°C 194°F 200°C 392°F	Dry and damp locations.	Fluorinated Ethylene Propylene	14-10 8-2		20	None
30																
Dry locations — special applications.†	Fluorinated Ethylene Propylene	14-8 6-2		14	Glass braid Asbestos or other suitable braid material											
				14												
Mineral Insulation (Metal Sheathed)	MI	90°C 194°F 250°C 482°F	Dry and wet locations. For special application.†	Magnesium Oxide	16-10 9-4 3-250		36	Copper								
							50									
							55									
Moisture-, Heat- and Oil-Resistant Thermoplastic	MTW	60°C 140°F  90°C 194°F	Machine tool wiring in wet locations as permitted in NFPA Standard No. 79. (See Article 670.) Machine tool wiring in dry locations as permitted in NFPA Standard No. 79. (See Article 670.)	Flame-Retardant, Moisture-, Heat- and Oil-Resistant Thermoplastic	22-12 10 8 6 4-2 1-4/0 213-500 501-1000		(A)	(B)	(A) None  (B) Nylon jacket or equivalent							
							30	15								
							30	20								
							45	30								
							60	30								
							60	40								
							80	50								
							95	60								
							110	70								

† Where environmental conditions require maximum conductor operating temperatures above 90°C.

Table 310-13 (Continued)

Paper		85°C 185°F	For underground service conductors, or by special permission.	Paper		Lead sheath
Perfluoroalkoxy	PFA	90°C 194°F 200°C 392°F	Dry and damp locations.  Dry locations — special applications.†	Perfluoroalkoxy	14-10 ..... 20 8-2 ..... 30 1-4/0 ..... 45	None
Perfluoroalkoxy	PFAH	250°C 482°F	Dry locations only. Only for leads within apparatus or within raceways connected to apparatus. (Nickel or nickel-coated copper only.)	Perfluoroalkoxy	14-10 ..... 20 8-2 ..... 30 1-4/0 ..... 45	None
Heat-Resistant Rubber	RH	75°C 167°F	Dry and damp locations.	Heat-Resistant Rubber	**14-12 ..... 30 10 ..... 45 8-2 ..... 60 1-4/0 ..... 80 213-500 ..... 95 501-1000 ..... 110 1001-2000 ..... 125 For 601-2000 volts, see Table 310-62.	*Moisture-resistant, flame-retardant, non-metallic covering
Heat-Resistant Rubber	RHH	90°C 194°F	Dry and damp locations.			
Moisture- and Heat-Resistant Rubber	RHW	75°C 167°F	Dry and wet locations. For over 2000 volts insulation shall be ozone-resistant.	Moisture- and Heat-Resistant Rubber	14-10 ..... 45 8-2 ..... 60 1-4/0 ..... 80 213-500 ..... 95 501-1000 ..... 110 1001-2000 ..... 125 For 601-2000 volts, see Table 310-62.	*Moisture-resistant, flame-retardant, non-metallic covering

\* Some rubber insulations do not require an outer covering.

\*\* For 14-12 sizes RHH shall be 45 mils thickness insulation.

† Where environmental conditions require maximum conductor operating temperatures above 90°C.

Table 310-13 (Continued)

Trade Name	Type Letter	Max. Operating Temp.	Application Provisions	Insulation	AWG or MCM	Thickness of Insulation	Mils	Outer Covering
Silicone-Asbestos	SA	90°C 194°F	Dry and damp locations.	Silicone Rubber	14-10	45	Asbestos, glass or other suitable braid material	
		125°C 257°F	For special application.†		8-2	60		
Synthetic Heat-Resistant	SIS	90°C 194°F	Switchboard wiring only.	Heat-Resistant Rubber	1-4/0	80	None	
					213-500	95		
Thermoplastic and Asbestos	TA	90°C 194°F	Switchboard wiring only.	Thermoplastic and Asbestos	501-1000	110	Flame-retardant, nonmetallic covering	
					1001-2000	125		
Thermoplastic and Fibrous Outer Braid	TBS	90°C 194°F	Switchboard wiring only.	Thermoplastic	14-10	30	Flame-retardant, nonmetallic covering	
					8	45		
Extruded Polytetrafluoroethylene	TFE	250°C 482°F	Dry locations only. Only for leads within apparatus or within raceways connected to apparatus, or as open wiring. (Nickel or nickel-coated copper only.)	Extruded Polytetrafluoroethylene	6-2	60	None	
					1-4/0	80		

† Where environmental conditions require maximum conductor operating temperatures above 90°C.



**Table 310-13 (Continued)**

Heat-Resistant Thermoplastic	THHN	90°C 194°F	Dry and damp locations.	Flame-Retardant, Heat-Resistant Thermoplastic	14-12 ..... 15 10 ..... 20 8-6 ..... 30 4-2 ..... 40 1-4/0 ..... 50 250-500 ..... 60 501-1000 ..... 70	Nylon jacket or equivalent
Moisture- and Heat-Resistant Thermoplastic	THW	75°C 167°F 90°C 194°F	Dry and wet locations.  Special applications within electric discharge lighting equipment. Limited to 1000 open-circuit volts or less. (Size 14-8 only as permitted in Section 410-31.)	Flame-Retardant, Moisture- and Heat-Resistant Thermoplastic	14-10 ..... 45 8-2 ..... 60 1-4/0 ..... 80 213-500 ..... 95 501-1000 ..... 110 1001-2000 ..... 125	None
Moisture- and Heat-Resistant Thermoplastic	THWN	75°C 167°F	Dry and wet locations.	Flame-Retardant, Moisture- and Heat-Resistant Thermoplastic	14-12 ..... 15 10 ..... 20 8-6 ..... 30 4-2 ..... 40 1-4/0 ..... 50 250-500 ..... 60 501-1000 ..... 70	Nylon jacket or equivalent
Moisture-Resistant Thermoplastic	TW	60°C 140°F	Dry and wet locations.	Flame-Retardant, Moisture-Resistant Thermoplastic	14-10 ..... 30 8 ..... 45 6-2 ..... 60 1-4/0 ..... 80 213-500 ..... 95 501-1000 ..... 110 1001-2000 ..... 125	None

**Table 310-13 (Continued)**

Trade Name	Type Letter	Max. Operating Temp.	Application Provisions	Insulation	AWG or MCM	Thickness of Insulation	Mils	Outer Covering
Underground Feeder & Branch-Circuit Cable-Single Conductor. (For Type UF cable employing more than one conductor, see Article 339.)	UF	60°C 140°F	See Article 339.	Moisture-Resistant	14-10 ..... *60 8-2 ..... *80 1-4/0 ..... *95			Integral with insulation
		**75°C 167°F		Moisture- and Heat-Resistant				
Underground Service-Entrance Cable-Single Conductor. (For Type USE cable employing more than one conductor, see Article 338.)	USE	75°C 167°F	See Article 338.	Heat- and Moisture-Resistant	12-10 ..... 45 8-2 ..... 60 1-4/0 ..... 80 213-500 ..... ***95 501-1000 ..... 110 1001-2000 ..... 125			Moisture-resistant non-metallic covering [See 338-1 (b).]

\* Includes integral jacket.

\*\* For ampacity limitation, see Section 339-5.

\*\*\* Insulation thickness shall be permitted to be 80 mils for listed Type USE conductors that have been subjected to special investigations.

The nonmetallic covering over individual rubber-covered conductors of aluminum-sheathed cable and of lead-sheathed or multiconductor cable shall not be required to be flame retardant. For Type MC cable, see Section 334-20. For nonmetallic-sheathed cable, see Section 336-25. For Type UF cable, see Section 339-1.

Table 310-13 (Continued)

Varnished Cambric	V	85°C 185°F	Dry locations only. Smaller than No. 6 by special permission.	Varnished Cambric	14-8 ..... 45 6-2 ..... 60 1-4/0 ..... 80 213-500 ..... 95 500-1000 ..... 110 1001-2000 ..... 125 For 1000-5000 volts, see Table 310-65 or 310-66.	Nonmetallic covering or lead sheath
Moisture- and Heat-Resistant Cross-Linked Synthetic Polymer	XHHW	90°C 194°F  75°C 167°F	Dry and damp locations.  Wet locations.	Flame-Retardant Cross-Linked Synthetic Polymer	14-10 ..... 30 8-2 ..... 45 1-4/0 ..... 55 213-500 ..... 65 501-1000 ..... 80 1001-2000 ..... 95	None
Modified Ethylene Tetrafluoroethylene	Z	90°C 194°F 150°C 302°F	Dry and damp locations.  Dry locations — special applications.†	Modified Ethylene Tetrafluoroethylene	14-12 ..... 15 10 ..... 20 8-4 ..... 25 3-1 ..... 35 1/0-4/0 ..... 45	None
Modified Ethylene Tetrafluoroethylene	ZW	75°C 167°F 90°C 194°F 150°C 302°F	Wet locations.  Dry and damp locations.  Dry locations — special applications.†	Modified Ethylene Tetrafluoroethylene	14-10 ..... 30 8-2 ..... 45	None

† Where environmental conditions require maximum conductor operating temperatures above 90°C.

**Table 310-16. Ampacities of Not More than Three Single Insulated Conductors, Rated 0 through 2000 Volts, in Raceway in Free Air and Ampacities of Cable Types AC, NM, NMC and SE Based on Ambient Air Temperature of 30°C (86°F).**

Size	Temperature Rating of Conductor. See Table 310-13.								Size
	60°C (140°F)	75°C (167°F)	85°C (185°F)	90°C (194°F)	60°C (140°F)	75°C (167°F)	85°C (185°F)	90°C (194°F)	
AWG	TYPES †TW, †UF	TYPES †FEPW, †TRH, †RHW, †THW, †THWN, †XHHW, †USE, †ZW	TYPE V	TYPES TA, TBS, SA, AVB, SIS, †FEP, †FEPB, †RHH, †THHN, †XHHW*	TYPES †TW, †UF	TYPES †RH, †RHW, †THW, †THWN, †XHHW †USE	TYPE V	TYPES TA, TBS, SA, AVB, SIS, †RHH, †THHN, †XHHW*	AWG
MCM									MCM
COPPER				ALUMINUM OR COPPER-CLAD ALUMINUM					
18	.....	.....	.....	14	.....	.....	.....	.....	.....
16	.....	.....	.....	18	.....	.....	.....	.....	.....
14	20†	20†	25	25†	.....	.....	.....	.....	.....
12	25†	25†	30	30†	20†	20†	25	25†	12
10	30	35†	40	40†	25	30†	30	35†	10
8	40	50	55	55	30	40	40	45	8
6	55	65	70	75	40	50	55	60	6
4	70	85	95	95	55	65	75	75	4
3	85	100	110	110	65	75	85	85	3
2	95	115	125	130	75	90	100	100	2
1	110	130	145	150	85	100	110	115	1
1/0	125	150	165	170	100	120	130	135	1/0
2/0	145	175	190	195	115	135	145	150	2/0
3/0	165	200	215	225	130	155	170	175	3/0
4/0	195	230	250	260	150	180	195	205	4/0
250	215	255	275	290	170	205	220	230	250
300	240	285	310	320	190	230	250	255	300
350	260	310	340	350	210	250	270	280	350
400	280	335	365	380	225	270	295	305	400
500	320	380	415	430	260	310	335	350	500
600	355	420	460	475	285	340	370	385	600
700	385	460	500	520	310	375	405	420	700
750	400	475	515	535	320	385	420	435	750
800	410	490	535	555	330	395	430	450	800
900	435	520	565	585	355	425	465	480	900
1000	455	545	590	615	375	445	485	500	1000
1250	495	590	640	665	405	485	525	545	1250
1500	520	625	680	705	435	520	565	585	1500
1750	545	650	705	735	455	545	595	615	1750
2000	560	665	725	750	470	560	610	630	2000

AMPACITY CORRECTION FACTORS									
Ambient Temp. °C	For ambient temperatures other than 30°C (86°F), multiply the ampacities shown above by the appropriate factor shown below.								Ambient Temp. °F
21-25	1.08	1.05	1.04	1.04	1.08	1.05	1.04	1.04	70-77
26-30	1.00	1.00	1.00	1.00	1.00	1.00	1.00	1.00	79-86
31-35	.91	.94	.95	.96	.91	.94	.95	.96	88-95
36-40	.82	.88	.90	.91	.82	.88	.90	.91	97-104
41-45	.71	.82	.85	.87	.71	.82	.85	.87	106-113
46-50	.58	.75	.80	.82	.58	.75	.80	.82	115-122
51-55	.41	.67	.74	.76	.41	.67	.74	.76	124-131
56-60	.....	.58	.67	.71	.....	.58	.67	.71	133-140
61-70	.....	.33	.52	.58	.....	.33	.52	.58	142-158
71-80	.....	.....	.30	.41	.....	.....	.30	.41	160-176

† Unless otherwise specifically permitted elsewhere in this Code, the overcurrent protection for conductor types marked with an obelisk (†) shall not exceed 15 amperes for 14 AWG, 20 amperes for 12 AWG, and 30 amperes for 10 AWG copper; or 15 amperes for 12 AWG and 25 amperes for 10 AWG aluminum and copper-clad aluminum after any correction factors for ambient temperature and number of conductors have been applied.

\* For dry and damp locations only. See 75°C column for wet locations.

**Table 310-17. Ampacities of Single Insulated Conductors, Rated 0 through 2000 Volts, In Free Air Based on Ambient Air Temperature of 30°C (86°F).**

Size	Temperature Rating of Conductor. See Table 310-13.								Size
	60°C (140°F)	75°C (167°F)	85°C (185°F)	90°C (194°F)	60°C (140°F)	75°C (167°F)	85°C (185°F)	90°C (194°F)	
	TYPE †TW	TYPES †FEPW, †RH, †RHW, †TW, †THWN, †XHHW, †ZW	TYPE V	TYPES TA, TBS, SA, AVB, SS, †FEP, †FEPB, †RHB, †RHH, †THHN, †XHHW*, MI	TYPE †TW	TYPES †RH, †RHW, †THW, †THWN, †XHHW	TYPE V	TYPES TA, TBS, SA, AVB, SS, †RHH, †THHN, †XHHW*, MI	
	COPPER				ALUMINUM OR COPPER-CLAD ALUMINUM				
18	.....	.....	.....	18	.....	.....	.....	.....	.....
16	.....	.....	23	24	.....	.....	.....	.....	.....
14	25†	30†	30	35†	.....	.....	.....	.....	.....
12	30†	35†	40	40†	25†	30†	30	35†	12
10	40†	50†	55	55†	35†	40†	40	40†	10
8	60	70	75	80	45	55	60	60	8
6	80	95	100	105	60	75	80	80	6
4	105	125	135	140	80	100	105	110	4
3	120	145	160	165	95	115	125	130	3
2	140	170	185	190	110	135	145	150	2
1	165	195	215	220	130	155	165	175	1
1/0	195	230	250	260	150	180	195	205	1/0
2/0	225	265	290	300	175	210	225	235	2/0
3/0	260	310	335	350	200	240	265	275	3/0
4/0	300	360	390	405	235	280	305	315	4/0
250	340	405	440	455	265	315	345	355	250
300	375	445	485	505	290	350	380	395	300
350	420	505	550	570	330	395	430	445	350
400	455	545	595	615	355	425	465	480	400
500	515	620	675	700	405	485	525	545	500
600	575	690	750	780	455	540	595	615	600
700	630	755	825	855	500	595	650	675	700
750	655	785	855	885	515	620	675	700	750
800	680	815	885	920	535	645	700	725	800
900	730	870	950	985	580	700	760	785	900
1000	780	935	1020	1055	625	750	815	845	1000
1250	890	1065	1160	1200	710	855	930	960	1250
1500	980	1175	1275	1325	795	950	1035	1075	1500
1750	1070	1280	1395	1445	875	1050	1145	1185	1750
2000	1155	1385	1505	1560	960	1150	1250	1335	2000

**AMPACITY CORRECTION FACTORS**

Ambient Temp. °C	For ambient temperatures other than 30°C (86°F), multiply the ampacities shown above by the appropriate factor shown below.								Ambient Temp. °F
21-25	1.08	1.05	1.04	1.04	1.08	1.05	1.04	1.04	70-77
26-30	1.00	1.00	1.00	1.00	1.00	1.00	1.00	1.00	79-86
31-35	.91	.94	.95	.96	.91	.94	.95	.96	88-95
36-40	.82	.88	.90	.91	.82	.88	.90	.91	97-104
41-45	.71	.82	.85	.87	.71	.82	.85	.87	106-113
46-50	.58	.75	.80	.82	.58	.75	.80	.82	115-122
51-55	.41	.67	.74	.76	.41	.67	.74	.76	124-131
56-60	.....	.58	.67	.71	.....	.58	.67	.71	133-140
61-70	.....	.33	.52	.58	.....	.33	.52	.58	142-158
71-80	.....	.....	.30	.41	.....	.....	.30	.41	160-176

† Unless otherwise specifically permitted elsewhere in this Code, the overcurrent protection for conductor types marked with an obelisk (†) shall not exceed 15 amperes for 14 AWG, 20 amperes for 12 AWG, and 30 amperes for 10 AWG copper; or 15 amperes for 12 AWG and 25 amperes for 10 AWG aluminum and copper-clad aluminum.

\* For dry and locations only. See 75°C column for wet locations.

**Table 310-18. Ampacities of Three Single Insulated Conductors Rated 0 through 2000 Volts, 110° to 250°C, in Raceway in Free Air Based on Ambient Air Temperature of 40°C (104°F).**

Size	Temperature Rating of Conductor. See Table 310-13.									Size
	110°C (230°F)	125°C (257°F)	150°C (302°F)	200°C (392°F)	250°C (482°F)	110°C (230°F)	125°C (257°F)	150°C (302°F)	200°C (392°F)	
	TYPES AVA, AVL	TYPES AI, AIA	TYPE Z	TYPES A, AA, FEP, FEPB, PFA	TYPES PFAH, TFE	TYPES AVA, AVL	TYPES AI, AIA	TYPE Z	TYPES A, AA	
AWG					NICKEL OR NICKEL- COATED COPPER	ALUMINUM OR COPPER- CLAD ALUMINUM				AWG
MCM	COPPER									MCM
14	29	31	34	36	39	25	27	30	35	14
12	36	39	43	45	54	37	40	44	47	12
10	46	50	55	60	73	48	52	57	65	10
8	64	69	76	83	93					8
6	81	87	96	110	117	63	68	75	86	6
4	109	118	120	125	148	85	92	94	98	4
3	129	139	143	152	166	96	104	109	119	3
2	143	154	160	171	191	111	120	124	133	2
1	168	181	186	197	215	131	141	145	154	1
1/0	193	208	215	229	244	150	162	169	183	1/0
2/0	229	247	251	260	273	179	193	198	208	2/0
3/0	263	284	288	297	308	205	221	227	238	3/0
4/0	301	325	332	346	361	235	253	260	275	4/0
250	345	372	.....	.....	.....	270	291	.....	.....	250
300	391	422	.....	.....	.....	306	330	.....	.....	300
350	436	470	.....	.....	.....	342	369	.....	.....	350
400	468	505	.....	.....	.....	368	397	.....	.....	400
500	531	573	.....	.....	.....	421	454	.....	.....	500
600	588	634	.....	.....	.....	471	508	.....	.....	600
700	645	696	.....	.....	.....	520	561	.....	.....	700
750	673	726	.....	.....	.....	545	588	.....	.....	750
800	699	754	.....	.....	.....	566	610	.....	.....	800
1000	785	846	.....	.....	.....	651	701	.....	.....	1000
1500	961	.....	.....	.....	.....	795	.....	.....	.....	1500
2000	1109	.....	.....	.....	.....	919	.....	.....	.....	2000

**AMPACITY CORRECTION FACTORS**

Ambient Temp. °C	For ambient temperatures other than 40°C (104°F), multiply the ampacities shown above by the appropriate factor shown below.									Ambient Temp. °F
41-50	.93	.94	.95	.97	.98	.93	.94	.95	.97	106-122
51-60	.85	.87	.90	.94	.95	.85	.87	.90	.94	124-140
61-70	.76	.80	.85	.90	.93	.76	.80	.85	.90	142-158
71-80	.65	.73	.80	.87	.90	.65	.73	.80	.90	160-176
81-90	.53	.64	.74	.83	.87	.53	.64	.74	.83	177-194
91-100	.38	.54	.67	.79	.85	.38	.54	.67	.79	195-212
101-120	.....	.24	.52	.71	.79	.....	.24	.52	.71	213-248
121-140	.....	.....	.30	.61	.72	.....	.....	.30	.61	249-284
141-160	.....	.....	.....	.50	.65	.....	.....	.....	.50	285-320
161-180	.....	.....	.....	.35	.58	.....	.....	.....	.35	321-356
181-200	.....	.....	.....	.....	.49	.....	.....	.....	.....	357-392
201-225	.....	.....	.....	.....	.35	.....	.....	.....	.....	393-437

**Table 310-19. Ampacities for Single Insulated Conductors Rated 0 through 2000 Volts, 110° to 250°C, in Free Air Based on Ambient Air Temperature of 40°C (104°F).**

Size	Temperature Rating of Conductor. See Table 310-13.								Size	
	110°C (230°F)	125°C (257°F)	150°C (302°F)	200°C (392°F)	250°C (482°F)	110°C (230°F)	125°C (257°F)	150°C (302°F)		200°C (392°F)
AWG MCM	TYPES AVA, AVL	TYPES AI, AIA	TYPE Z	TYPES A, AA, FEP, FEPB, PFA	TYPES PFAH, TFE	TYPES AVA, AVL	TYPES AI, AIA	TYPE Z	TYPES A, AA	AWG MCM
COPPER					NICKEL OR NICKEL- COATED COPPER	ALUMINUM OR COPPER- CLAD ALUMINUM				
14	39	42	46	54	59	40	43	47	54	14
12	51	55	60	68	78	53	57	63	71	12
10	67	72	80	90	107	70	75	83	96	10
8	90	97	106	124	142					8
6	121	131	155	165	205	95	102	112	128	6
4	160	172	190	220	278	125	135	148	171	4
3	180	194	214	252	327	144	155	170	196	3
2	215	232	255	293	381	167	180	198	227	2
1	247	266	293	344	440	193	208	228	267	1
1/0	286	309	339	399	532	222	239	263	310	1/0
2/0	329	355	390	467	591	257	277	305	363	2/0
3/0	380	410	451	546	708	296	319	351	443	3/0
4/0	446	481	529	629	830	347	374	411	490	4/0
250	493	532	.....	.....	.....	384	414	.....	.....	250
300	552	595	.....	.....	.....	431	464	.....	.....	300
350	611	659	.....	.....	.....	477	514	.....	.....	350
400	663	715	.....	.....	.....	518	559	.....	.....	400
500	767	827	.....	.....	.....	600	647	.....	.....	500
600	860	928	.....	.....	.....	674	727	.....	.....	600
700	953	1028	.....	.....	.....	749	808	.....	.....	700
750	1000	1079	.....	.....	.....	786	848	.....	.....	750
800	1039	1121	.....	.....	.....	818	882	.....	.....	800
1000	1197	1291	.....	.....	.....	947	1021	.....	.....	1000
1500	1465	1580	.....	.....	.....	1160	1251	.....	.....	1500
2000	1692	1825	.....	.....	.....	1340	1444	.....	.....	2000

**AMPACITY CORRECTION FACTORS**

Ambient Temp. °C	For ambient temperatures other than 40°C (104°F), multiply the ampacities shown above by the appropriate factor shown below.									Ambient Temp. °F
41-50	.93	.94	.95	.97	.98	.93	.94	.95	.97	106-122
51-60	.85	.87	.90	.94	.95	.85	.87	.90	.94	124-140
61-70	.76	.80	.85	.90	.93	.76	.80	.85	.90	142-158
71-80	.65	.73	.80	.87	.90	.65	.73	.80	.87	160-176
81-90	.53	.64	.74	.83	.87	.53	.64	.74	.83	177-194
91-100	.38	.54	.67	.79	.85	.38	.54	.67	.79	195-212
101-120	.....	.24	.52	.71	.79	.....	.24	.52	.71	213-248
121-140	.....	.....	.30	.61	.72	.....	.....	.30	.61	249-284
141-160	.....	.....	.....	.50	.65	.....	.....	.....	.50	285-320
161-180	.....	.....	.....	.35	.58	.....	.....	.....	.35	321-356
181-200	.....	.....	.....	.....	.49	.....	.....	.....	.....	357-392
201-225	.....	.....	.....	.....	.35	.....	.....	.....	.....	393-437

**Table 310-22. Ampacities of Three Insulated Conductors, Rated 0 through 2000 Volts, Within an Overall Covering (Three Conductor Cable), in Raceway in Free Air Based on Ambient Air Temperature of 30°C (86°F)**

Size	Temperature Rating of Conductor. See Table 310-13.						Size
	60°C (140°F)	75°C (167°F)	90°C (194°F)	60°C (140°F)	75°C (167°F)	90°C (194°F)	
AWG MCM	TYPE †TW	TYPES †RH, †RHW, †THW, †THWN, †XHHW*, †ZW	TYPES †THHN, †RHH, †XHHW*	TYPE †TW	TYPES †RH, †RHW, †THW, †THWN, †XHHW	TYPES †THHN, †RHH, †XHHW*	AWG MCM
COPPER			ALUMINUM OR COPPER-CLAD ALUMINUM				
14	16†	18†	21†				14
12	20†	24†	27†	16†	18†	21†	12
10	27†	33†	36†	21†	25†	28†	10
8	36	43	48	28	33	37	8
6	48	58	65	38	45	51	6
4	66	79	89	51	61	69	4
3	76	90	102	59	70	79	3
2	88	105	119	69	83	93	2
1	102	121	137	80	95	106	1
1/0	121	145	163	94	113	127	1/0
2/0	138	166	186	108	129	146	2/0
3/0	158	189	214	124	147	167	3/0
4/0	187	223	253	147	176	197	4/0
250	205	245	276	160	192	217	250
300	234	281	317	185	221	250	300
350	255	305	345	202	242	273	350
400	274	328	371	218	261	295	400
500	315	378	427	254	303	342	500
600	343	413	468	279	335	378	600
700	376	452	514	310	371	420	700
750	387	466	529	321	384	435	750
800	397	479	543	331	397	450	800
900	415	500	570	350	421	477	900
1000	448	542	617	382	460	521	1000
Ambient Temp. °C	For ambient temperatures other than 30°C (86°F) multiply the ampacities shown above by the appropriate factor shown below.						Ambient Temp. °F
21-25	1.08	1.05	1.04	1.08	1.05	1.04	70-77
26-30	1.00	1.00	1.00	1.00	1.00	1.00	79-86
31-35	.91	.94	.96	.91	.94	.96	88-95
36-40	.82	.88	.91	.82	.88	.91	97-104
41-45	.71	.82	.87	.71	.82	.87	106-113
46-50	.58	.75	.82	.58	.75	.82	115-122
51-55	.41	.67	.76	.41	.67	.76	124-131
56-60	.....	.58	.71	.....	.58	.71	133-140
61-70	.....	.33	.58	.....	.33	.58	142-158
71-80	.....	.....	.41	.....	.....	.41	160-176

† Unless otherwise specifically permitted elsewhere in this Code, the overcurrent protection for conductor types marked with an obelisk (†) shall not exceed 15 amperes for 14 AWG, 20 amperes for 12 AWG, and 30 amperes for 10 AWG copper; or 15 amperes for 12 AWG and 25 amperes for 10 AWG aluminum and copper-clad aluminum.

\* For dry and damp locations only. See 75°C column for wet locations.



**Table 310-23. Ampacities of Two or Three Single Insulated Conductors, Rated 0 through 2000 Volts, Supported on a Messenger, Based on Ambient Air Temperature of 40°C (104°F)**

Size	Temperature Rating of Conductor. See Table 310-13.				Size
	75°C (167°F)	90°C (194°F)	75°C (167°F)	90°C (194°F)	
AWG	TYPES RH, RHW, THW, THWN, XHHW, ZW	TYPES THHN, RHH, XHHW*	TYPES RH, RHW, THW, THWN, XHHW	TYPES THHN, RHH, XHHW*	AWG
MCM	COPPER		ALUMINUM OR COPPER-CLAD ALUMINUM		MCM
8	57	66	44	51	8
6	76	89	59	69	6
4	101	117	78	91	4
3	118	138	92	107	3
2	135	158	106	123	2
1	158	185	123	144	1
1/0	183	214	143	167	1/0
2/0	212	247	165	193	2/0
3/0	245	287	192	224	3/0
4/0	287	335	224	262	4/0
250	320	374	251	292	250
300	359	419	282	328	300
350	397	464	312	364	350
400	430	503	339	395	400
500	496	580	392	458	500
600	553	647	440	514	600
700	610	714	488	570	700
750	638	747	512	598	750
800	660	773	532	622	800
900	704	826	572	669	900
1000	748	879	612	716	1000
Ambient Temp. °C	For ambient temperatures other than 40°C (104°F) multiply the ampacities shown above by the appropriate factor shown below.				Ambient Temp. °F
21-25	1.20	1.14	1.20	1.14	70-77
26-30	1.13	1.10	1.13	1.10	79-86
31-35	1.07	1.05	1.07	1.05	88-95
36-40	1.00	1.00	1.00	1.00	97-104
41-45	.93	.95	.93	.95	106-113
46-50	.85	.89	.85	.89	119-122
51-55	.76	.84	.76	.84	124-131
56-60	.65	.77	.65	.77	133-140
61-70	.38	.63	.38	.63	142-158
71-80	....	.45	....	.45	160-176

\* For dry and damp locations only. See 75°C column for wet locations.

**Table 310-24. Ampacities for Bare or Covered Conductors  
Based on 40°C Ambient, 80°C Total Conductor Temperature,  
2 Feet (610-mm) per Second Wind Velocity**

Bare Copper Conductors		Covered Copper Conductors	
AWG MCM	AMPS	AWG MCM	AMPS
8	98	8	103
6	124	6	130
4	155	4	163
2	209	2	219
1/0	282	1/0	297
2/0	329	2/0	344
3/0	382	3/0	401
4/0	444	4/0	466
250	494	250	519
300	556	300	584
500	773	500	812
750	1000	750	1050
1000	1193	1000	1253
Bare AAC Aluminum Conductor		Covered AAC Aluminum	
AWG MCM	AMPS	AWG MCM	AMPS
8	76	8	80
6	96	6	101
4	121	4	127
2	163	2	171
1/0	220	1/0	231
2/0	255	2/0	268
3/0	297	3/0	312
4/0	346	4/0	364
266.8	403	266.8	423
336.4	468	336.4	492
397.5	522	397.5	548
477.0	588	477.0	617
556.5	650	556.5	682
636.0	709	636.0	744
795.0	819	795.0	860
954.0	920		
1033.5	968	1033.5	1017
1272	1103	1272	1201
1590	1267	1590	1381
2000	1454	2000	1527

**Table 310-25. Ampacities of Single Insulated Conductors, Rated 0 through 2000 Volts, in Nonmagnetic Underground Electrical Ducts. (One Conductor per Electrical Duct)**  
**Based on Ambient Earth Temperature of 20°C (68°F), Electrical Duct Arrangement as per Figure 310-1, 100 Percent Load Factor, Thermal Resistance (RHO) of 90, Conductor Temperature 75°C (167°F)**

Size							Size
MCM	3 Electrical Ducts (Fig. 310-1) Detail 2	6 Electrical Ducts (Fig. 310-1) Detail 3	9 Electrical Ducts (Fig. 310-1) Detail 4	3 Electrical Ducts (Fig. 310-1) Detail 2	6 Electrical Ducts (Fig. 310-1) Detail 3	9 Electrical Ducts (Fig. 310-1) Detail 4	MCM
	TYPES RHW, THW, THWN, XHHW, USE	TYPES RHW, THW, THWN, XHHW, USE	TYPES RHW, THW, THWN, XHHW, USE	TYPES RHW, THW, THWN, XHHW, USE	TYPES RHW, THW, THWN, XHHW, USE	TYPES RHW, THW, THWN, XHHW, USE	
	COPPER			ALUMINUM OR COPPER-CLAD ALUMINUM			
250	344	295	270	269	230	211	250
350	418	355	322	327	277	252	350
500	511	431	387	401	337	305	500
750	640	534	469	505	421	375	750
1000	745	617	533	593	491	432	1000
1250	832	686	581	668	551	478	1250
1500	907	744	619	736	604	517	1500
1750	970	793	651	796	651	550	1750
2000	1027	836	683	850	693	581	2000

Ambient Temp. °C	For ambient temperatures other than 20°C (68°F) multiply the ampacities shown above by the appropriate factor shown below.						Ambient Temp. °F
6-10	1.09	1.09	1.09	1.09	1.09	1.09	43-50
11-15	1.04	1.04	1.04	1.04	1.04	1.04	52-59
16-20	1.00	1.00	1.00	1.00	1.00	1.00	61-68
21-25	.95	.95	.95	.95	.95	.95	70-77
26-30	.90	.90	.90	.90	.90	.90	79-86

### Notes to Tables 310-25 through 310-27

**1. Ampacity of Electrical Duct Bank with Two Electrical Ducts.** To obtain the ampacity of cables installed in two electrical ducts in one horizontal row with 7.5-inch (190.7-mm) center-to-center spacing between electrical ducts, similar to Detail 1, Figure 310-1, multiply the ampacity shown for one electrical duct in Tables 310-26 and 310-27 by 0.88.

**2. Ampacity of Electrical Duct Bank with Four Electrical Ducts.** To obtain the ampacity of cables installed in four electrical ducts in one horizontal row with 7.5-inch (190.7-mm) center-to-center spacing between electrical ducts, similar to Detail 2, Figure 310-1, multiply the ampacity shown for three electrical ducts in Tables 310-26 and 310-27 by 0.94.

**3. Electrical Ducts Utilized in Figure 310-1 Include any of the Electrical Conduits Recognized in Chapter 3 as Suitable for Use Underground.** When metal conduit is used as an electrical duct in Figure 310-1, the minimum burial depth for all details is 6 inches (152 mm) as permitted by Table 300-5.

**Table 310-26. Ampacities of Three Insulated Conductors, Rated 0 through 2000 Volts, Within an Overall Covering (Three Conductor Cable) in Underground Electrical Ducts (One Cable per Electrical Duct) Based on Ambient Earth Temperature of 20°C (68°F), Electrical Duct Arrangement as per Figure 310-1, 100 Percent Load Factor, Thermal Resistance (RHO) of 90, Conductor Temperature 75°C (167°F)**

Size							Size
AWG. MCM	1 Electrical Duct (Fig. 310-1) Detail 1	3 Electrical Ducts (Fig. 310-1) Detail 2	6 Electrical Ducts (Fig. 310-1) Detail 3	1 Electrical Duct (Fig. 310-1) Detail 1	3 Electrical Ducts (Fig. 310-1) Detail 2	6 Electrical Ducts (Fig. 310-1) Detail 3	AWG MCM
	TYPES RHW, THW, THWN, XHHW, USE	TYPES RHW, THW, THWN, XHHW, USE	TYPES RHW, THW, THWN, XHHW, USE	TYPES RHW, THW, THWN, XHHW, USE	TYPES RHW, THW, THWN, XHHW, USE	TYPES RHW, THW, THWN, XHHW, USE	
COPPER				ALUMINUM OR COPPER-CLAD ALUMINUM			
14	23†	21†	19†	.....	.....	.....	14
12	29†	26†	24†	.....	.....	.....	12
10	39†	34†	31†	.....	.....	.....	10
8	54	48	42	42	37	32	8
6	71	63	54	55	49	42	6
4	93	81	69	72	63	54	4
2	121	105	89	94	82	70	2
1	140	121	102	109	94	79	1
1/0	160	137	116	125	107	90	1/0
2/0	183	156†	131	143	122	102	2/0
3/0	210	178	148	164	139	116	3/0
4/0	240	202	168	187	158	131	4/0
250	265	222	184	207	174	144	250
350	321	267	219	252	209	172	350
500	389	320	261	308	254	207	500
750	478	388	314	386	314	254	750
1000	539	435	351	447	361	291	1000

Ambient Temp. °C	For ambient temperatures other than 20°C (68°F) multiply the ampacities shown above by the appropriate factor shown below.						Ambient Temp. °F
6-10	1.09	1.09	1.09	1.09	1.09	1.09	43-50
11-15	1.04	1.04	1.04	1.04	1.04	1.04	52-59
16-20	1.00	1.00	1.00	1.00	1.00	1.00	61-68
21-25	.95	.95	.95	.95	.95	.95	70-77
26-30	.90	.90	.90	.90	.90	.90	79-86

† Unless otherwise specifically permitted elsewhere in this Code, the overcurrent protection for conductor types marked with an obelisk (†) shall not exceed 15 amperes for 14 AWG, 20 amperes for 12 AWG and 30 amperes for 10 AWG copper; or 15 amperes for 12 AWG and 25 amperes for 10 AWG aluminum and copper-clad aluminum.

**Table 310-27. Ampacities of Three Single Insulated Conductors, Rated 0 through 2000 Volts, in Underground Electrical Ducts (Three Conductors per Electrical Duct) Based on Ambient Earth Temperature of 20°C (68°F), Electrical Duct Arrangement per Figure 310-1, 100 Percent Load Factor, Thermal Resistance (RHO) of 90, Conductor Temperature 75°C (167°F)**

Size							Size
AWG MCM	1 Electrical Duct (Fig. 310-1 Detail 1)	3 Electrical Ducts (Fig. 310-1 Detail 2)	6 Electrical Ducts (Fig. 310-1 Detail 3)	1 Electrical Duct (Fig. 310-1 Detail 1)	3 Electrical Ducts (Fig. 310-1 Detail 2)	6 Electrical Ducts (Fig. 310-1 Detail 3)	AWG MCM
	TYPES †RHW, †THW, †THWN, †XHHW, †USE	TYPES †RHW, †THW, †THWN, †XHHW, †USE	TYPES †RHW, †THW, †THWN, †XHHW, †USE	TYPES †RHW, †THW, †THWN, †XHHW, †USE	TYPES †RHW, †THW, †THWN, †XHHW, †USE	TYPES †RHW, †THW, †THWN, †XHHW, †USE	
	COPPER			ALUMINUM OR COPPER-CLAD ALUMINUM			
14	24†	22†	16†	24†	22†	18†	14
12	36†	31†	24†	36†	31†	25†	12
10	46†	41†	32†	46†	41†	34	10
8	58	51	44	58	51	44	8
6	77	67	56	77	67	56	6
4	100	86	73	100	86	73	4
3	116	99	83	116	99	83	3
2	132	112	93	132	112	93	2
1	153	128	106	153	128	106	1
1/0	175	146	121	175	146	121	1/0
2/0	200	166	136	200	166	136	2/0
3/0	228	189	154	228	189	154	3/0
4/0	263	215	175	263	215	175	4/0
250	290	236	192	290	236	192	250
300	321	260	210	321	260	210	300
350	351	283	228	351	283	228	350
400	376	302	243	376	302	243	400
500	427	341	273	427	341	273	500
600	468	371	296	468	371	296	600
700	509	402	319	509	402	319	700
750	529	417	330	529	417	330	750
800	544	428	338	544	428	338	800
900	575	450	355	575	450	355	900
1000	605	472	372	605	472	372	1000
Ambient Temp. °C	For ambient temperatures other than 20°C (68°F) multiply the ampacities shown above by the appropriate factor shown below.						Ambient Temp. °F
6-10	1.09	1.09	1.09	1.09	1.09	1.09	43-50
11-15	1.04	1.04	1.04	1.04	1.04	1.04	52-59
16-20	1.00	1.00	1.00	1.00	1.00	1.00	61-68
21-25	.95	.95	.95	.95	.95	.95	70-77
26-30	.90	.90	.90	.90	.90	.90	79-86

†Unless otherwise specifically permitted elsewhere in this Code, the overcurrent protection for conductor types marked with an obelisk (†) shall not exceed 15 amperes for 14 AWG, 20 amperes for 12 AWG and 30 amperes for 10 AWG copper; or 15 amperes for 12 AWG and 25 amperes for 10 AWG aluminum and copper-clad aluminum.

**Table 310-28. Ampacities of Two or Three Insulated Conductors, Rated 0 through 2000 Volts, Cabled Within an Overall (Two or Three Conductor) Covering Directly Buried in Earth Based on Ambient Earth Temperature of 20°C (68°F), Arrangement per Figure 310-1, 100 Percent Load Factor, Thermal Resistance (RHO) of 90**

Size									Size
	1 Cable (Fig. 310-1 Detail 5)		2 Cables (Fig. 310-1 Detail 6)		1 Cable (Fig. 310-1 Detail 5)		2 Cables (Fig. 310-1 Detail 6)		
AWG MCM	60°C (140°F)	75°C (167°F)	60°C (140°F)	75°C (167°F)	60°C (140°F)	75°C (167°F)	60°C (140°F)	75°C (167°F)	AWG MCM
	TYPES		TYPES		TYPES		TYPES		
	†UF	†RHW, †THW, †THWN, †XHHW, †USE	†UF	†RHW, †THW, †THWN, †XHHW, †USE	†UF	†RHW, †THW, †THWN, †XHHW, †USE	†UF	†RHW, †THW, †THWN, †XHHW, †USE	
	COPPER				ALUMINUM OR COPPER-CLAD ALUMINUM				
14	30†	32†	26†	30†	...	...	...	...	14
12	38†	43†	34†	41†	30†	34†	26†	32†	12
10	47†	56†	43†	52†	38†	45†	34†	41†	10
8	64	75	60	70	51	59	47	55	8
6	85	100	81	95	68	75	60	70	6
4	107	125	100	117	83	97	78	91	4
2	137	161	128	150	107	126	110	117	2
1	155	182	145	170	121	142	113	132	1
1/0	177	208	165	193	138	162	129	151	1/0
2/0	201	236	188	220	157	184	146	171	2/0
3/0	229	269	213	250	179	210	166	195	3/0
4/0	259	304	241	282	203	238	188	220	4/0
250		333		308		261		241	250
350		401		370		315		290	350
500		481		442		381		350	500
750		585		535		473		433	750
1000		657		600		545		497	1000

Ambient Temp. °C	For ambient temperatures other than 20°C (68°F) multiply the ampacities shown above by the appropriate factor shown below.								Ambient Temp. °F
6-10	1.12	1.09	1.12	1.09	1.12	1.09	1.12	1.09	43-50
11-15	1.06	1.04	1.06	1.04	1.06	1.04	1.06	1.04	52-59
16-20	1.00	1.00	1.00	1.00	1.00	1.00	1.00	1.00	61-68
21-25	.94	.95	.94	.95	.94	.95	.94	.95	70-77
26-30	.87	.90	.87	.90	.87	.90	.87	.90	79-86

For ampacities of UF cable in underground electrical ducts, multiply the ampacities shown in the table by 0.74.

†Unless otherwise specifically permitted elsewhere in this Code, the overcurrent protection for conductor types marked with an obelisk (†) shall not exceed 15 amperes for 14 AWG, 20 amperes for 12 AWG and 30 amperes for 10 AWG copper; or 15 amperes for 12 AWG and 25 amperes for 10 AWG aluminum and copper-clad aluminum.

**Table 310-29. Ampacities of Three Triplexed Single Insulated Conductors, Rated 0 through 2000 Volts, Directly Buried in Earth Based on Ambient Earth Temperature of 20°C (68°F), Arrangement per Figure 310-1, 100 Percent Load Factor, Thermal Resistance (RHO) of 90**

Size										Size	
AWG	MCM	See Fig. 310-1 Detail 7		See Fig. 310-1 Detail 8		See Fig. 310-1 Detail 7		See Fig. 310-1 Detail 8		AWG	MCM
		60°C (140°F)	75°C (167°F)	60°C (140°F)	75°C (167°F)	60°C (140°F)	75°C (167°F)	60°C (140°F)	75°C (167°F)		
		TYPES		TYPES		TYPES		TYPES			
		†UF	†USE	†UF	†USE	†UF	†USE	†UF	†USE		
		COPPER				ALUMINUM OR COPPER-CLAD ALUMINUM					
14		31†	37†	30†	35†	...	...	...	...		14
12		41†	48†	39†	46†	32†	38†	31†	36†		12
10		54†	63†	50†	59†	42†	49†	39†	46†		10
8		72	84	66	77	55	65	51	60		8
6		91	107	84	99	72	84	66	77		6
4		119	139	109	128	92	108	85	100		4
2		153	179	140	164	119	139	109	128		2
1		173	203	159	186	135	158	124	145		1
1/0		197	231	181	212	154	180	141	165		1/0
2/0		223	262	205	240	175	205	159	187		2/0
3/0		254	298	232	272	199	233	181	212		3/0
4/0		289	339	263	308	226	265	206	241		4/0
250			370		336		289		263		250
350			445		403		349		316		350
500			536		483		424		382		500
750			654		587		525		471		750
1000			744		665		608		544		1000

Ambient Temp. °C	For ambient temperatures other than 20°C (68°F) multiply the ampacities shown above by the appropriate factor shown below.								Ambient Temp. °F
6-10	1.12	1.09	1.12	1.09	1.12	1.09	1.12	1.09	43-50
11-15	1.06	1.04	1.06	1.04	1.06	1.04	1.06	1.04	52-59
16-20	1.00	1.00	1.00	1.00	1.00	1.00	1.00	1.00	61-68
21-25	.94	.95	.94	.95	.94	.95	.94	.95	70-77
26-30	.87	.90	.87	.90	.87	.90	.87	.90	79-86

†Unless otherwise specifically permitted elsewhere in this Code, the overcurrent protection for conductor types marked with an obelisk (†) shall not exceed 15 amperes for 14 AWG; 20 amperes for 12 AWG and 30 amperes for 10 AWG copper; or 15 amperes for 12 AWG and 25 amperes for 10 AWG aluminum and copper-clad aluminum.

**Table 310-30. Ampacities of Three Single Insulated Conductors, Rated 0 through 2000 Volts, Directly Buried in Earth Based on Ambient Earth Temperature of 20°C (68°F), Arrangement per Figure 310-1; 100 Percent Load Factor, Thermal Resistance (RHO) of 90**

Size										Size	
AWG	MCM	See Fig. 310-1 Detail 9		See Fig. 310-1 Detail 10		See Fig. 310-1 Detail 9		See Fig. 310-1 Detail 10		AWG	MCM
		60°C (140°F)	75°C (167°F)	60°C (140°F)	75°C (167°F)	60°C (140°F)	75°C (167°F)	60°C (140°F)	75°C (167°F)		
TYPES		TYPES		TYPES		TYPES		TYPES			
UF	USE	UF	USE	UF	USE	UF	USE	UF	USE		
COPPER						ALUMINUM OR COPPER-CLAD ALUMINUM					
8	84		78		66		61			8	
6	107		101		84		78			6	
4	139		130		108		101			4	
2	178		165		139		129			2	
1	201		187		157		146			1	
1/0	230		212		179		165			1/0	
2/0	261		241		204		188			2/0	
3/0	297		274		232		213			3/0	
4/0	336		309		262		241			4/0	
250		429		394		335		308		250	
350		516		474		403		370		350	
.500		626		572		490		448		500	
750		767		700		605		552		750	
1000		887		808		706		642		1000	
1250		979		891		787		716		1250	
1500		1063		965		862		783		1500	
1750		1133		1027		930		843		1750	
2000		1195		1082		990		897		2000	

Ambient Temp. °C	For ambient temperatures other than 20°C (68°F) multiply the ampacities shown above by the appropriate factor shown below.								Ambient Temp. °F
6-10	1.12	1.09	1.12	1.09	1.12	1.09	1.12	1.09	43-50
11-15	1.06	1.04	1.06	1.04	1.06	1.04	1.06	1.04	52-59
16-20	1.00	1.00	1.00	1.00	1.00	1.00	1.00	1.00	61-68
21-25	.94	.95	.94	.95	.94	.95	.94	.95	70-77
26-30	.87	.90	.87	.90	.87	.90	.87	.90	79-86



**Table 310-31. Ampacities of Multiconductor Cables with not more than Three Insulated Conductors, Rated 0 through 2000 Volts, in Free Air. Based on Ambient Air Temperature of 40°C (104°F) (For TC, MC, MI and SNM cables)†**

Size	Temperature Rating of Conductor. See Table 310-13.								Size
	60°C (140°F)	75°C (167°F)	85°C (185°F)	90°C (194°F)	60°C (140°F)	75°C (167°F)	85°C (185°F)	90°C (194°F)	
AWG	COPPER				ALUMINUM OR COPPER-CLAD ALUMINUM				AWG
MCM	COPPER				ALUMINUM OR COPPER-CLAD ALUMINUM				MCM
18				11†					18
16				16†					16
14	18†	21†	24†	25†					14
12	21†	28†	30†	32†	18†	21†	24†	25†	12
10	28†	36†	41†	43†	21†	28†	30†	32†	10
8	39	50	56	59	30	39	44	46	8
6	52	68	75	79	41	53	59	61	6
4	69	89	100	104	54	70	78	81	4
3	81	104	116	121	63	81	91	95	3
2	92	118	132	138	72	92	103	108	2
1	107	138	154	161	84	108	120	126	1
1/0	124	160	178	186	97	125	139	145	1/0
2/0	143	184	206	215	111	144	160	168	2/0
3/0	165	213	238	249	129	166	185	194	3/0
4/0	190	245	274	287	149	192	214	224	4/0
250	212	274	305	320	166	214	239	250	250
300	237	306	341	357	186	240	268	280	300
350	261	337	377	394	205	265	296	309	350
400	281	363	406	425	222	287	317	334	400
500	321	416	465	487	255	330	368	385	500
600	354	459	513	538	284	368	410	429	600
700	387	502	562	589	306	405	462	473	700
750	404	523	586	615	328	424	473	495	750
800	415	539	604	633	339	439	490	513	800
900	438	570	639	670	362	469	514	548	900
1000	461	601	674	707	385	499	558	584	1000

Ambient Temp. °C	For ambient temperatures other than 40°C (104°F) multiply the ampacities shown above by the appropriate factor shown below.								Ambient Temp. °F
21-25	1.32	1.20	1.15	1.14	1.32	1.20	1.15	1.14	70-77
26-30	1.22	1.13	1.11	1.10	1.22	1.13	1.11	1.10	79-86
31-35	1.12	1.07	1.05	1.05	1.12	1.07	1.05	1.05	88-95
36-40	1.00	1.00	1.00	1.00	1.00	1.00	1.00	1.00	97-104
41-45	.87	.93	.94	.95	.87	.93	.94	.95	106-113
46-50	.71	.85	.88	.89	.71	.85	.88	.89	115-122
51-55	.50	.76	.82	.84	.50	.76	.82	.84	124-131
56-60	.....	.65	.75	.77	.....	.65	.75	.77	133-140
61-70	.....	.38	.58	.63	.....	.38	.58	.63	142-158
71-80	.....	.....	.33	.44	.....	.....	.33	.44	160-176

†Unless otherwise specifically permitted elsewhere in this Code, the overcurrent protection for conductor types marked with an obelisk (†) shall not exceed 7 amperes for 18 AWG, 10 amperes for 16 AWG, and 15 amperes for 14 AWG, 20 amperes for 12 AWG, and 30 amperes for 10 AWG copper; or 15 amperes for 12 AWG and 25 amperes for 10 AWG aluminum and copper-clad aluminum.

## Notes to Tables 310-16 through 310-31

**1. Explanation of Tables.** For explanation of Type Letters, and for recognized size of conductors for the various conductor insulations, see Section 310-13. For installation requirements, see Sections 310-1 through 310-10, and the various articles of this Code. For flexible cords, see Tables 400-4 and 400-5.

**3. Three-Wire, Single-Phase Dwelling Services.** In dwelling units, conductors, as listed below, shall be permitted to be utilized as three-wire, single-phase, service-entrance conductors and the three-wire, single-phase feeder that carries the total current supplied by that service. Grounded service-entrance conductors shall be permitted to be two AWG sizes smaller than the ungrounded conductors provided the requirements of Section 230-42 are met.

**Conductor Types and Sizes**  
**RH-RHH-RHW-THW-THWN-THHN-XHHW**

Copper	Aluminum and Copper-Clad AL	Service Rating in Amps
AWG	AWG	
4	2	100
3	1	110
2	1/0	125
1	2/0	150
1/0	3/0	175
2/0	4/0	200

**5. Bare Conductors.** Where bare conductors are used with insulated conductors, their allowable ampacities shall be limited to that permitted for the adjacent insulated conductors.

**6. Mineral-Insulated, Metal-Sheathed Cable.** The temperature limitation on which the ampacities of mineral-insulated, metal-sheathed cable are based is determined by the insulating materials used in the end seal. Termination fittings incorporating unimpregnated, organic, insulating materials are limited to 90°C operation.

**7. Type MTW Machine Tool Wire.**

(FPN): For the ampacities of Type MTW wire, see Table 13-1(c) in the Electrical Standard for Industrial Machinery (NFPA 79-1985).

**8. Ampacity Adjustment Factors.**

(a) **More than Three Conductors in a Raceway or Cable.** Where the number of conductors in a raceway or cable exceeds three, the ampacities given in Tables 310-16, 310-18, 310-22, 310-26, 310-27, 310-28, 310-29, 310-30, and 310-31 shall be reduced as shown in the following table:

Number of Conductors	Percent of Values in Tables 310-16, 310-18, 310-22, 310-26, 310-27, 310-28, 310-29, 310-30, and 310-31, as Adjusted for Ambient Temperature if Necessary	
	4 thru 6	
7 thru 9		70
10 thru 24*		70
25 thru 42*		60
43 and above*		50

\* These factors include the effects of a load diversity of 50 percent.

Where single conductors or multiconductor cables are stacked or bundled longer than 24 inches (610 mm) without maintaining spacing and are not installed in raceways, the ampacity of each conductor shall be reduced as shown in the above table.

*Exception No. 1: When conductors of different systems, as provided in Section 300-3, are installed in a common raceway the derating factors shown above shall apply to the number of power and lighting (Articles 210, 215, 220, and 230) conductors only.*

*Exception No. 2: For conductors installed in cable trays, the provisions of Section 318-11 shall apply.*

*Exception No. 3: Derating factors do not apply to conductors in nipples having a length not exceeding 24 inches (610 mm).*

*Exception No. 4: Derating factors do not apply to underground conductors entering or leaving an outdoor trench if those conductors have physical protection in the form of rigid metal conduit, intermediate metal conduit or rigid nonmetallic conduit Schedule 80 having a length not exceeding 10 feet (3.05 m) and the number of conductors in a conduit does not exceed 4.*

**(b) More than One Conduit, Tube, or Raceway.** Spacing between conduits, tubing, or raceways shall be maintained.

**9. Overcurrent Protection.** Where the standard ratings and settings of overcurrent devices do not correspond with the ratings and settings allowed for conductors, the next higher standard rating and setting shall be permitted.

*Exception: As limited in Section 240-3.*

#### 10. Neutral Conductor.

(a) A neutral conductor which carries only the unbalanced current from other conductors, as in the case of normally balanced circuits of three or more conductors, shall not be counted when applying the provisions of Note 8.

(b) In a 3-wire circuit consisting of 2-phase wires and the neutral of a 4-wire, 3-phase wye-connected system, a common conductor carries approximately the same current as the other conductors and shall be counted when applying the provisions of Note 8.

(c) On a 4-wire, 3-phase wye circuit where the major portion of the load consists of electric-discharge lighting, data processing, or similar equipment, there are harmonic currents present in the neutral conductor and the neutral shall be considered to be a current-carrying conductor.

**11. Grounding or Bonding Conductor.** A grounding or bonding conductor shall not be counted when applying the provisions of Note 8.

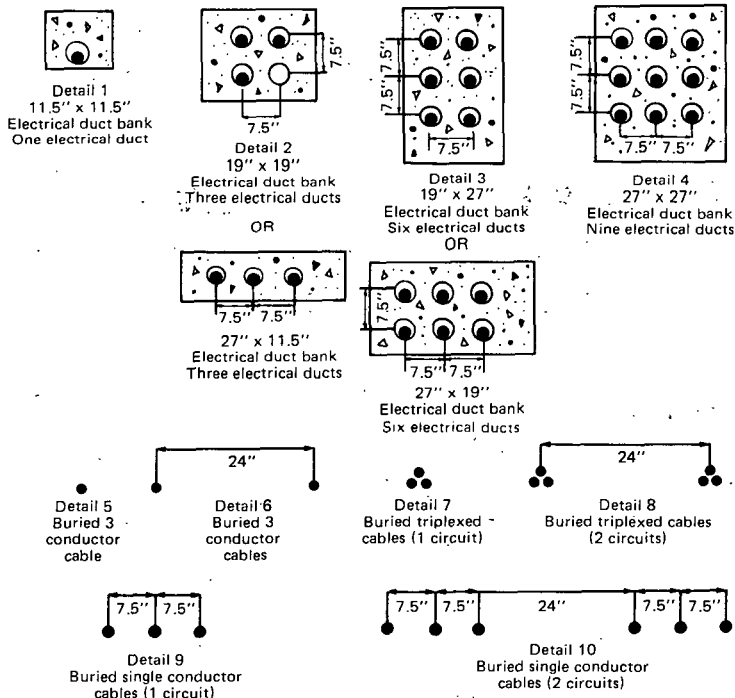

Notes for all details:

1. Minimum burial depths to top electrical ducts or cables shall be in accordance with Section 300-5. Maximum depth to the top of electrical duct banks shall be 30", and maximum depth to the top of direct buried cables shall be 36".
2. For two and four electrical duct installations with electrical ducts installed in a single row, see the Notes to Tables 310-25 through 310-27.
3. For SI units: one inch = 25.4 millimeters; one foot = 305 millimeters.

**Legend**

- Backfill, maximum Rho = 90 (Earth or concrete)
- Electrical duct
- Cable or cables

**Figure 310-1. Cable Installation Dimensions for Use with Tables 310-25 through 310-30 and 310-77 through 310-84**

**Table 310-61. Conductor Application and Insulation**

Trade Name	Type Letter	Maximum Operating Temperature	Application Provision	Insulation	Outer Covering
Medium voltage solid dielectric	MV-75 MV-85 MV-90	75C 85C 90C	Dry or wet locations rated 2001 volts and higher	Thermoplastic or Thermosetting	Jacket, Sheath or Armor

**Table 310-62. Thickness of Insulation for 601-2000 Volt Nonshielded Types RHH and RHW, in Mils**

Conductor Size AWG-MCM	A	B
14-10	80	60
8	80	70
6-2	95	70
1-2/0	110	90
3/0-4/0	110	90
213-500	125	105
501-1000	140	120

Note: Column A insulations are limited to natural, SBR, and butyl rubbers.

Note: Column B insulations are materials such as cross-linked polyethylene, ethylene propylene rubber, and composites thereof.

**Table 310-63. Thickness of Insulation and Jacket for Nonshielded Solid Dielectric Insulated Conductors Rated 2001 to 8000 Volts, in Mils**

Conductor Size AWG-MCM	2001-5000 Volts						5001-8000 Volts 100 Percent Insulation Level Wet or Dry Locations		
	Dry Locations Single Conductor			Wet or Dry Locations			Single Conductor		Multi- Conductor*
	Without Jacket	With Jacket		Single Conductor		Multi- Conductor*			
	Insulation	Insulation	Jacket	Insulation	Jacket	Insulation	Insulation	Jacket	Insulation
8	110	90	30	125	80	90	180	80	180
6	110	90	30	125	80	90	180	80	180
4-2	110	90	45	125	80	90	180	95	180
1-2/0	110	90	45	125	80	90	180	95	180
3/0-4/0	110	90	65	125	95	90	180	110	180
213-500	120	90	65	140	110	90	210	110	210
501-750	130	90	65	155	125	90	235	125	235
751-1000	130	90	65	155	125	90	250	140	250

\*Note: Under a common overall covering such as a jacket, sheath or armor.

**Table 310-64. Thickness of Insulation for Shielded Solid Dielectric Insulated Conductors Rated 2001 to 35,000 Volts, in Mils**

Conductor Size AWG-MCM	2001- 5000 Volts	5001-8000		8001-15,000		15,001-25,000		25,001- 28,000	28,001- 35,000
		100* Per- cent Insu- lation level	133* Per- cent Insu- lation level	100* Per- cent insu- lation level	133* Per- cent insu- lation level	100* Per- cent insu- lation level	133* Per- cent insu- lation level	100* Per- cent insu- lation level	100* Per- cent insu- lation level
8	90	—	—	—	—	—	—	—	—
6-4	90	115	140	—	—	—	—	—	—
2	90	115	140	175	215	—	—	—	—
1	90	115	140	175	215	260	345	280	—
1/0-1000	90	115	140	175	215	260	345	280	345

**\*Definitions:**

**100 Percent Insulation Level.** Cables in this category shall be permitted to be applied where the system is provided with relay protection such that ground faults will be cleared as rapidly as possible, but in any case within 1 minute. While these cables are applicable to the great majority of cable installations which are on grounded systems, they shall be permitted to be used also on other systems for which the application of cables is acceptable provided the above clearing requirements are met in completely de-energizing the faulted section.

**133 Percent Insulation Level.** This insulation level corresponds to that formerly designated for ungrounded systems. Cables in this category shall be permitted to be applied in situations where the clearing time requirements of the 100 percent level category cannot be met, and yet there is adequate assurance that the faulted section will be de-energized in a time not exceeding 1 hour. Also they shall be permitted to be used when additional insulation strength over the 100 percent level category is desirable.

**Table 310-65. Thickness of Varnished-Cambric Insulation for Single-Conductor Cable, in Mils**

Conductor Size AWG or MCM	For Voltages Not Exceeding				
	1000	2000	3000	4000	5000
14	60	—	—	—	—
12	60	80	—	—	—
10	60	80	95	—	—
8-2	60	80	95	110	140
1-4/0	80	95	95	110	140
213-500	95	95	110	125	155
501-1000	110	110	110	125	155
1001-2000	125	125	125	140	155

**Table 310-66. Thickness of Varnished-Cambric Insulation for Multiconductor Cable, in Mils**

Conductor Size AWG or MCM	For Voltages Not Exceeding									
	1000		2000		3000		4000		5000	
	C	B	C	B	C	B	C	B	C	B
14	60	0	—	—	—	—	—	—	—	—
12	60	0	80	0	—	—	—	—	—	—
10	60	0	80	0	80	30	—	—	—	—
8-2	60	0	80	0	80	30	95	45	95	60
1-4/0	80	0	95	0	95	30	95	45	95	60
213-500	95	0	95	0	95	30	95	45	110	60
501-1000	95	30	95	30	95	45	95	60	110	60
1001-2000	110	30	110	30	110	45	110	60	110	80

The thickness given in columns headed "C" are for the insulation on the individual conductors. Those given in the columns headed "B" are for the thickness of the overall belt of insulation.

**Table 310-67  
Thickness of Asbestos and Varnished-Cambric Insulation for Single-Conductor Cable, Types AVA, AVB, and AVL, in Mils**

Conductor, AWG or MCM	Asbestos 1st Wall	Varnished Cambric					Asbestos 2nd Wall
	For Voltages Not Exceeding						
	1000-5000	1000	2000	3000	4000	5000	1000-5000
14-2	15	45	60	80	100	120	25
1-4/0	20	45	60	80	100	120	30
213-500	25	45	60	80	100	120	40
501-1000	30	45	60	80	100	120	40
1001-2000	30	55	75	95	115	140	50



**Table 310-69**  
**Ampacities for Insulated Single Copper**  
**Conductor Isolated in Air**  
**Based on Conductor Temperature of 90°C and Ambient**  
**Air Temperature of 40°C**

Conductor Size AWG-MCM	2001-5000 Volts Ampacity	5001-15,000 Volts Ampacity	15,001-35,000 Volts Ampacity
8	83	—	—
6	110	110	—
4	145	150	—
2	190	195	—
1	225	225	225
1/0	260	260	260
2/0	300	300	300
3/0	345	345	345
4/0	400	400	395
250	445	445	440
350	550	550	545
500	695	685	680
750	900	885	870
1000	1075	1060	1040
1250	1230	1210	1185
1500	1365	1345	1315
1750	1495	1470	1430
2000	1605	1575	1535

**Table 310-70**  
**Ampacities for Insulated Single Aluminum Conductor**  
**Isolated in Air**  
**Based on Conductor Temperature of 90°C and Ambient**  
**Air Temperature of 40°C**

Conductor Size AWG-MCM	2001-5000 Volts Ampacity	5001-15,000 Volts Ampacity	15,001-35,000 Volts Ampacity
8	64	—	—
6	85	87	—
4	115	115	—
2	150	150	—
1	175	175	175
1/0	200	200	200
2/0	230	235	230
3/0	270	270	270
4/0	310	310	310
250	345	345	345
350	430	430	430
500	545	535	530
750	710	700	685
1000	855	840	825
1250	980	970	950
1500	1105	1085	1060
1750	1215	1195	1165
2000	1320	1295	1265

**Table 310-71**  
**Ampacities of an Insulated Three Conductor Copper**  
**Cable Isolated in Air**  
**Based on Conductor Temperature of 90°C and Ambient**  
**Air Temperature of 40°C**

<b>Conductor Size AWG-MCM</b>	<b>2001-5000 Volts Ampacity</b>	<b>5001-35,000 Volts Ampacity</b>
8	59	—
6	79	93
4	105	120
2	140	165
1	160	185
1/0	185	215
2/0	215	245
3/0	250	285
4/0	285	325
250	320	360
350	395	435
500	485	535
750	615	670
1000	705	770

**Table 310-72**  
**Ampacities of an Insulated Three Conductor**  
**Aluminum Cable Isolated in Air**  
**Based on Conductor Temperature of 90°C and Ambient**  
**Air Temperature of 40°C**

<b>Conductor Size AWG-MCM</b>	<b>2001-5000 Volts Ampacity</b>	<b>5001-35,000 Volts Ampacity</b>
8	46	—
6	61	72
4	81	95
2	110	125
1	125	145
1/0	145	170
2/0	170	190
3/0	195	220
4/0	225	255
250	250	280
350	310	345
500	385	425
750	495	540
1000	585	635

**Table 310-73**  
**Ampacities of an Insulated Triplexed or Three Single**  
**Conductor Copper Cables in Isolated Conduit in Air**  
**Based on Conductor Temperature of 90°C and Ambient**  
**Air Temperature of 40°C**

Conductor Size AWG-MCM	2001-5000 Volts Ampacity	5001-35,000 Volts Ampacity
8	55	—
6	75	83
4	97	110
2	130	150
1	155	170
1/0	180	195
2/0	205	225
3/0	240	260
4/0	280	295
250	315	330
350	385	395
500	475	480
750	600	585
1000	690	675

**Table 310-74**  
**Ampacities of Insulated Triplexed or Three Single**  
**Conductor Aluminum Cables in Isolated Conduit in Air**  
**Based on Conductor Temperature of 90°C and Ambient**  
**Air Temperature of 40°C**

Conductor Size AWG-MCM	2001-5000 Volts Ampacity	5001-35,000 Volts Ampacity
8	43	—
6	58	65
4	76	84
2	100	115
1	120	130
1/0	140	150
2/0	160	175
3/0	190	200
4/0	215	230
250	250	255
350	305	310
500	380	385
750	490	485
1000	580	565

**Table 310-75**  
**Ampacities of an Insulated Three Conductor**  
**Copper Cable in Isolated Conduit in Air**  
**Based on Conductor Temperature of 90°C and Ambient**  
**Air Temperature of 40°C**

<b>Conductor Size AWG-MCM</b>	<b>2001-5000 Volts Ampacity</b>	<b>5001-35,000 Volts Ampacity</b>
8	52	—
6	69	83
4	91	105
2	125	145
1	140	165
1/0	165	195
2/0	190	220
3/0	220	250
4/0	255	290
250	280	315
350	350	385
500	425	470
750	525	570
1000	590	650

**Table 310-76**  
**Ampacities of an Insulated Three Conductor**  
**Aluminum Cable in Isolated Conduit in Air**  
**Based on Conductor Temperature of 90°C and Ambient**  
**Air Temperature of 40°C**

Conductor Size AWG-MCM	2001-5000 Volts Ampacity	5001-35,000 Volts Ampacity
8	41	—
6	53	64
4	71	84
2	96	115
1	110	130
1/0	130	150
2/0	150	170
3/0	170	195
4/0	200	225
250	220	250
350	275	305
500	340	380
750	430	470
1000	505	550

Table 310-77.

**Ampacities of Three Single Insulated Copper Conductors in Underground Electrical Ducts (Three Conductors per Electrical Duct) Based on Ambient Earth Temperature of 20°C (68°F), Electrical Duct Arrangement per Figure 310-1, 100% Load Factor, Thermal Resistance (RHO) of 90, Conductor Temperature 90°C (104°F)**

One Circuit (See Figure 310-1, Detail 1) Size AWG-MCM	2001-5000 Volts Ampacity	5001-35,000 Volts Ampacity
8	64	—
6	85	90
4	110	115
2	145	155
1	170	175
1/0	195	200
2/0	220	230
3/0	250	260
4/0	290	295
250	320	325
350	385	390
500	470	465
750	585	565
1000	670	640
<b>Three Circuit (See Figure 310-1, Detail 2). Size</b>		
8	56	—
6	73	77
4	95	99
2	125	130
1	140	145
1/0	160	165
2/0	185	185
3/0	210	210
4/0	235	240
250	260	260
350	315	310
500	375	370
750	460	440
1000	525	495
<b>Six Circuit (See Figure 310-1, Detail 3) Size</b>		
8	48	—
6	62	64
4	80	82
2	105	105
1	115	120
1/0	135	135
2/0	150	150
3/0	170	170
4/0	195	190
250	210	210
350	250	245
500	300	290
750	365	350
1000	410	390

**Table 310-78**

**Ampacities of Three Single Insulated Aluminum Conductors in Underground Electrical Ducts (Three Conductors per Electrical Duct) Based on Ambient Earth Temperature of 20°C (68°F), Electrical Duct Arrangement per Figure 310-1, 100% Load Factor, Thermal Resistance (RHO) of 90, Conductor Temperature 90°C (104°F)**

<b>One Circuit (See Figure 310-1, Detail 1) Size AWG-MCM</b>	<b>2001-5000 Volts Ampacity</b>	<b>5001-35,000 Volts Ampacity</b>
8	50	—
6	66	70
4	86	91
2	115	120
1	130	135
1/0	150	155
2/0	170	175
3/0	195	200
4/0	225	230
250	250	250
350	305	305
500	370	370
750	470	455
1000	545	525
<b>Three Circuit (See Figure 310-1, Detail 2) Size</b>		
8	44	—
6	57	60
4	74	77
2	96	100
1	110	110
1/0	125	125
2/0	145	145
3/0	160	165
4/0	185	185
250	205	200
350	245	245
500	295	290
750	370	355
1000	425	405
<b>Six Circuit (See Figure 310-1, Detail 3) Size</b>		
8	38	—
6	48	50
4	62	64
2	80	80
1	91	90
1/0	105	105
2/0	115	115
3/0	135	130
4/0	150	150
250	165	165
350	195	195
500	240	230
750	290	280
1000	335	320

**Table 310-79**

**Ampacities of Three Insulated Copper Conductors Cabled Within an Overall Covering (Three Conductor Cable) in Underground Electrical Ducts (One Cable per Electrical Duct) Based on Ambient Earth Temperature of 20°C (68°F), Electrical Duct Arrangement per Figure 310-1, 100% Load Factor, Thermal Resistance (RHO) of 90, Conductor Temperature 90°C (104°F)**

One Circuit (See Figure 310-1, Detail 1) Size AWG-MCM	2001-5000 Volts Ampacity	5001-35,000 Volts Ampacity
8	59	—
6	78	88
4	100	115
2	135	150
1	155	170
1/0	175	195
2/0	200	220
3/0	230	250
4/0	265	285
250	290	310
350	355	375
500	430	450
750	530	545
1000	600	615
<b>Three Circuit</b> (See Figure 310-1, Detail 2) Size		
8	53	—
6	69	75
4	89	97
2	115	125
1	135	140
1/0	150	160
2/0	170	185
3/0	195	205
4/0	225	230
250	245	255
350	295	305
500	355	360
750	430	430
1000	485	485
<b>Six Circuit</b> (See Figure 310-1, Detail 3) Size		
8	46	—
6	60	63
4	77	81
2	98	105
1	110	115
1/0	125	130
2/0	145	150
3/0	165	170
4/0	185	190
250	200	205
350	240	245
500	290	290
750	350	340
1000	390	380



Table 310-80

**Ampacities of Three Insulated Aluminum Conductors Cabled Within an Overall Covering (Three Conductor Cable) in Underground Electrical Ducts (One Cable per Electrical Duct) Based on Ambient Earth Temperature of 20°C (68°F), Electrical Duct Arrangement per Figure 310-1, 100% Load Factor, Thermal Resistance (RHO) of 90, Conductor Temperature 90°C (104°F)**

<b>One Circuit (See Figure 310-1, Detail 1) Size AWG-MCM</b>	<b>2001-5000 Volts Ampacity</b>	<b>5001-35,000 Volts Ampacity</b>
8	46	—
6	61	69
4	80	89
2	105	115
1	120	135
1/0	140	150
2/0	160	170
3/0	180	195
4/0	205	220
250	230	245
350	280	295
500	340	355
750	425	440
1000	495	510
<b>Three Circuit (See Figure 310-1, Detail 2) Size</b>		
8	41	—
6	54	59
4	70	75
2	90	100
1	105	110
1/0	120	125
2/0	135	140
3/0	155	160
4/0	175	180
250	190	200
350	230	240
500	280	285
750	345	350
1000	400	400
<b>Six Circuit (See Figure 310-1, Detail 3) Size</b>		
8	36	—
6	46	49
4	60	63
2	77	80
1	87	90
1/0	99	105
2/0	110	115
3/0	130	130
4/0	145	150
250	160	160
350	190	190
500	230	230
750	280	275
1000	320	315

**Table 310-81**  
**Ampacities of Single Insulated Copper Conductors**  
**Directly Buried in Earth**  
**Based on Ambient Earth Temperature of 20°C (68°F),**  
**Arrangement per Figure 310-1, 100% Load Factor,**  
**Thermal Resistance (RHO) of 90, Conductor Temperature 90°C (104°F)**

<b>Conductor Size AWG-MCM</b>	<b>2001-5000 Volts Ampacity</b>	<b>5001-35,000 Volts Ampacity</b>
<b>One Circuit- 3 Conductors (See Figure 310-1, Detail 9)</b>		
8	110	—
6	140	130
4	180	170
2	230	210
1	260	240
1/0	295	275
2/0	335	310
3/0	385	355
4/0	435	405
250	470	440
350	570	535
500	690	650
750	845	805
1000	980	930
<b>Two Circuits- 6 Conductors (See Figure 310-1, Detail 10)</b>		
8	100	—
6	130	120
4	165	160
2	215	195
1	240	225
1/0	275	255
2/0	310	290
3/0	355	330
4/0	400	375
250	435	410
350	520	495
500	630	600
750	775	740
1000	890	855

For SI units: one inch = 25.4 millimeters.

**Table 310-82**  
**Ampacities of Single Insulated Aluminum Conductors**  
**Directly Buried in Earth**

**Based on Ambient Earth Temperature of 20°C (68°F),**  
**Arrangement per Figure 310-1, 100% Load Factor,**  
**Thermal Resistance (RHO) of 90, Conductor Temperature 90°C (104°F)**

<b>Conductor Size AWG-MCM</b>	<b>2001-5000 Volts Ampacity</b>	<b>5001-35,000 Volts Ampacity</b>
<b>One Circuit- 3 Conductors (See Figure 310-1, Detail 9)</b>		
8	85	—
6	110	100
4	140	130
2	180	165
1	205	185
1/0	230	215
2/0	265	245
3/0	300	275
4/0	340	315
250	370	345
350	445	415
500	540	510
750	665	635
1000	780	740
<b>Two Circuits- 6 Conductors (See Figure 310-1, Detail 10)</b>		
8	80	—
6	100	95
4	130	125
2	165	155
1	190	175
1/0	215	200
2/0	245	225
3/0	275	255
4/0	310	290
250	340	320
350	410	385
500	495	470
750	610	580
1000	710	680

For SI units: one inch = 25.4 millimeters.

**Table 310-83**  
**Ampacities of Three Insulated Copper Conductors Cabled**  
**Within an Overall Covering (Three Conductor Cable),**  
**Directly Buried in Earth**  
**Based on Ambient Earth Temperature of 20°C (68°F),**  
**Arrangement per Figure 310-1, 100% Load Factor,**  
**Thermal Resistance (RHO) of 90, Conductor Temperature 90°C (104°F)**

<b>Conductor Size AWG-MCM</b>	<b>2001-5000 Volts Ampacity</b>	<b>5001-35,000 Volts Ampacity</b>
<b>One Circuit (See Figure 310-1, Detail 5)</b>		
8	85	—
6	105	115
4	135	145
2	180	185
1	200	210
1/0	230	240
2/0	260	270
3/0	295	305
4/0	335	350
250	365	380
350	440	460
500	530	550
750	650	665
1000	730	750
<b>Two Circuits (See Figure 310-1, Detail 6)</b>		
8	80	—
6	100	105
4	130	135
2	165	170
1	185	195
1/0	215	220
2/0	240	250
3/0	275	280
4/0	310	320
250	340	350
350	410	420
500	490	500
750	595	605
1000	665	675

For SI units: one inch = 25.4 millimeters.

Table 310-84

**Ampacities of Three Insulated Aluminum Conductors Cabled  
Within an Overall Covering (Three Conductor Cable),  
Directly Buried in Earth**

**Based on Ambient Earth Temperature of 20°C (68°F),  
Arrangement per Figure 310-1, 100% Load Factor,  
Thermal Resistance (RHO) of 90, Conductor Temperature 90°C (104°F)**

<b>Conductor Size AWG-MCM</b>	<b>2001-5000 Volts Ampacity</b>	<b>5001-35,000 Volts Ampacity</b>
<b>One Circuit (See Figure 310-1, Detail 5)</b>		
8	65	—
6	80	90
4	105	115
2	140	145
1	155	165
1/0	180	185
2/0	205	210
3/0	230	240
4/0	260	270
250	285	300
350	345	360
500	420	435
750	520	540
1000	600	620
<b>Two Circuits (See Figure 310-1, Detail 6)</b>		
8	60	—
6	75	80
4	100	105
2	130	135
1	145	150
1/0	165	170
2/0	190	195
3/0	215	220
4/0	245	250
250	265	275
350	320	330
500	385	395
750	480	485
1000	550	560

For SI units: one inch = 25.4 millimeters.

**Notes to Tables 310-69 through 310-84**

(FPN): For ampacities calculated in accordance with the following Notes 1 and 2, reference IEEE/ICEA "Power Cable Ampacities" Vols. I and II (IPCEA Pub. No. P-46-426) and "The References" therein for availability of all factors and constants.

**1. Ambients Not in Tables.** Ampacities at ambient temperatures other than those shown in the tables shall be determined by means of the following formula:

$$I_2 = I_1 \sqrt{\frac{TC - TA_2 - \text{DELTA TD}}{TC - TA_1 - \text{DELTA TD}}}$$

Where,

$I_1$  = Ampacity from tables at ambient  $TA_1$

$I_2$  = Ampacity at desired ambient  $TA_2$

TC = Conductor temperature in degrees C

$TA_1$  = Surrounding ambient from tables in degrees C

$TA_2$  = Desired ambient in degrees C.

DELTA TD = Dielectric loss temperature rise.

**2. Grounded Shields.** Ampacities shown in Tables 310-69, 310-70, 310-81 and 310-82 are for cable with shields grounded at one point only. When shields are grounded at more than one point, ampacities shall be adjusted to take into consideration the heating due to shield currents.

**3. Electrical Duct Bank Configuration.** Ampacities shown in Tables 310-77, 310-78, 310-79 and 310-84 shall apply only when the cables are located in the outer electrical ducts of the electrical duct bank. Ampacities for cables located in the inner electrical ducts of the electrical duct bank will have to be determined by special calculations.

## ARTICLE 318 — CABLE TRAYS

**318-1. Scope.** This article covers cable tray systems including ladders, troughs, channels, solid bottom trays, and other similar structures:

**318-2. Definition.**

**Cable Tray System.** A unit or assembly of units or sections, and associated fittings, forming a rigid structural system used to support cables.

**318-3. Uses Permitted.**

**(a) Wiring Methods.** The following shall be permitted to be installed in cable tray systems under the conditions described in their respective articles:

(1) Mineral-insulated, metal-sheathed cable (Article 330); (2) armored cable (Article 333); (3) metal-clad cable (Article 334); (4) power-limited tray cable (Section 725-40); (5) nonmetallic-sheathed cable (Article 336); (6) shielded, nonmetallic-sheathed cable (Article 337); (7) multiconductor service-entrance cable (Article 338); (8) multiconductor underground feeder and branch-circuit cable (Article 339); (9) power and control tray cable (Article 340); (10) other factory-assembled, multiconductor control, signal, or power cables, which are specifically approved for installation in cable trays; or (11) any approved conduit or raceway with its contained conductors.

**(b) In Industrial Establishments.** In industrial establishments only, where conditions of maintenance and supervision assure that only qualified persons will service the installed cable tray system, any of the cables in (1) and (2) below shall be permitted to be installed in ladder, ventilated trough, 4-inch (102-mm) ventilated channel-type cable trays, or 6-inch (152-mm) ventilated channel-type cable trays.

**(1) Single Conductor.** Single conductor cables shall be 250 MCM or larger and shall be of a type listed for use in cable trays. Where exposed to direct rays of the sun, cables shall be identified as being sunlight-resistant.

*Exception: Welding cables as permitted in Article 630, Part E.*

**(2) Multiconductor.** Multiconductor cables Type MV (Article 326) where exposed to direct rays of the sun shall be identified as being sunlight-resistant.

**(c) Equipment Grounding Conductors.** Metal in cable trays, as defined in Table 318-7(b) (2), shall be permitted to be used as equipment grounding conductors in commercial and industrial establishments, only where continuous maintenance and supervision assure that qualified persons will service the installed cable tray system.

**(d) Hazardous (Classified) Locations.** Cable trays in hazardous (classified) locations shall contain only the cable types permitted in Sections 501-4, 502-4, and 503-3.

(FPN): It is not the intent of this article to limit the use of cable trays to industrial establishments only.

**(e) Nonmetallic Cable Tray.** Nonmetallic cable tray shall be permitted in corrosive areas and in areas requiring voltage isolation.

**318-4. Uses Not Permitted.** Cable tray systems shall not be used in hoistways or where subject to severe physical damage.

**318-5. Construction Specifications.**

(a) **Strength and Rigidity.** Cable trays shall have suitable strength and rigidity to provide adequate support for all contained wiring.

(b) **Smooth Edges.** Cable trays shall not present sharp edges, burrs, or projections which may damage the insulation or jackets of the wiring.

(c) **Corrosion Protection.** Cable trays shall be made of corrosion-resistant material or, if made of metal, shall be adequately protected against corrosion.

(d) **Side Rails.** Cable trays shall have side rails or equivalent structural members.

(e) **Fittings.** Cable trays shall include fittings or other suitable means for changes in direction and elevation of runs.

(f) **Nonmetallic Cable Tray.** Nonmetallic cable tray shall be made of flame-retardant material.

**318-6. Installation.**

(a) **Complete System.** Cable trays shall be installed as a complete system. Field bends or modifications shall be so made that the electrical continuity of the cable tray system and support for the cables shall be maintained.

(b) **Completed Before Installation.** Each run of cable tray shall be completed before the installation of cables.

(c) **Supports.** Supports shall be provided to prevent stress on cables where they enter raceways or other enclosures from cable tray systems.

(d) **Covers.** In portions of runs where additional protection is required, covers or enclosures providing the required protection shall be of a material compatible with the cable tray.

(e) **Multiconductor Cables Rated 600 Volts or Less.** Multiconductor cables rated 600 volts or less shall be permitted to be installed in the same cable tray.

(f) **Cables Rated Over 600 Volts.** Cables rated over 600 volts shall not be installed in the same cable tray with cables rated 600 volts or less.

*Exception No. 1: Where separated by a solid fixed barrier of a material compatible with the cable tray.*

*Exception No. 2: Where cables over 600 volts are Type MC.*

(g) **Through Partitions and Walls.** Cable trays shall be permitted to extend transversely through partitions and walls or vertically through platforms and floors in wet or dry locations where the installations, complete with installed cables, are made in accordance with the requirements of Section 300-21.



(h) **Exposed and Accessible.** Cable trays shall be exposed and accessible except as permitted by Section 318-6(g).

(i) **Adequate Access.** Sufficient space shall be provided and maintained about cable trays to permit adequate access for installing and maintaining the cables.

(FPN): See Section 310-10 for temperature limitation of conductors.

### 318-7. Grounding.

(a) **Metallic Cable Trays.** Metallic cable trays which support electrical conductors shall be grounded as required for conductor enclosures in Article 250.

(b) **Steel or Aluminum Cable Tray Systems:** Steel or aluminum cable tray systems shall be permitted to be used as equipment grounding conductors provided that all the following requirements are met:

(1) The cable tray sections and fittings shall be identified for grounding purposes.

(2) The minimum cross-sectional area of cable trays shall conform to the requirements in Table 318-7(b)(2).

(3) All cable tray sections and fittings shall be legibly and durably marked to show the cross-sectional area of metal in channel-type cable trays or cable trays of one-piece construction, and the total cross-sectional area of both side rails for ladder or trough-type cable trays.

(4) Cable tray sections, fittings, and connected raceways shall be bonded in accordance with Section 250-75 using bolted mechanical connectors or bonding jumpers sized and installed in accordance with Section 250-79.

### 318-8. Cable Installation.

(a) **Cable Splices.** Cable splices made and insulated by approved methods shall be permitted to be located within a cable tray provided they are accessible and do not project above the side rails.

(b) **Fastened Securely.** In other than horizontal runs, the cables shall be fastened securely to transverse members of the cable trays.

(c) **Bushed Conduit.** A box shall not be required where cables or conductors are installed in bushed conduit used for support or for protection against physical damage.

(d) **Connected in Parallel.** Where single conductor cables comprising each phase or neutral of a circuit are connected in parallel as permitted in Section 310-4, the conductors shall be installed in groups consisting of not more than one conductor per phase or neutral, to prevent current unbalance in the paralleled conductors due to inductive reactance.

Single conductors shall be securely bound in circuit groups to prevent excessive movement due to fault-current magnetic forces.

*Exception: Where single conductors are cabled together, such as triplexed assemblies.*

**Table 318-7(b) (2)**  
**Metal Area Requirements for Cable Trays**  
**Used as Equipment Grounding Conductors**

Maximum Fuse Ampere Rating, Circuit Breaker Ampere Trip Setting, or Circuit Breaker Protective Relay Ampere Trip Setting for Ground-Fault Protection of any Cable Circuit in the Cable Tray System	Minimum Cross-Sectional Area of Metal* in Square Inches	
	Steel Cable Trays	Aluminum Cable Trays
60	0.20	0.20
100	0.40	0.20
200	0.70	0.20
400	1.00	0.40
600	1.50**	0.40
1000	—	0.60
1200	—	1.00
1600	—	1.50
2000	—	2.00**

For SI units: one square inch = 645 square millimeters.

\* Total cross-sectional area of both side rails for ladder or trough-type cable trays; or the minimum cross-sectional area of metal in channel-type cable trays or cable trays of one-piece construction.

\*\* Steel cable trays shall not be used as equipment grounding conductors for circuits with ground-fault protection above 600 amperes. Aluminum cable trays shall not be used as equipment grounding conductors for circuits with ground-fault protection above 2000 amperes.

**318-9. Number of Multiconductor Cables, Rated 2000 Volts, Nominal, or Less, in Cable Trays.** The number of multiconductor cables, rated 2000 volts, nominal, or less, permitted in a single cable tray shall not exceed the requirements of this section. The conductor sizes herein apply to both aluminum and copper conductors.

(a) **Any Mixture of Cables.** Where ladder or ventilated trough cable trays contain multiconductor power or lighting cables, or any mixture of multiconductor power, lighting, control, and signal cables, the maximum number of cables shall conform to the following:

(1) Where all of the cables are 4/0 AWG or larger, the sum of the diameters of all cables shall not exceed the cable tray width, and the cables shall be installed in a single layer.

(2) Where all of the cables are smaller than 4/0 AWG, the sum of the cross-sectional areas of all cables shall not exceed the maximum allowable cable fill area in Column 1 of Table 318-9, for the appropriate cable tray width.

(3) Where 4/0 AWG or larger cables are installed in the same cable tray with cables smaller than 4/0 AWG, the sum of the cross-sectional areas of all cables smaller than 4/0 AWG shall not exceed the maximum allowable fill

area resulting from the computation in Column 2 of Table 318-9, for the appropriate cable tray width. The 4/0 AWG and larger cables shall be installed in a single layer and no other cables shall be placed on them.

**(b) Multiconductor Control and/or Signal Cables Only.** Where a ladder or ventilated trough cable tray, having a usable inside depth of 6 inches (152 mm) or less, contains multiconductor control and/or signal cables only, the sum of the cross-sectional areas of all cables at any cross section shall not exceed 50 percent of the interior cross-sectional area of the cable tray. A depth of 6 inches (152 mm) shall be used to compute the allowable interior cross-sectional area of any cable tray which has a usable inside depth of more than 6 inches (152 mm).

**(c) Solid Bottom Cable Trays Containing Any Mixture.** Where solid bottom cable trays contain multiconductor power or lighting cables, or any mixture of multiconductor power, lighting, control, and signal cables, the maximum number of cables shall conform to the following:

(1) Where all of the cables are 4/0 AWG or larger, the sum of the diameters of all cables shall not exceed 90 percent of the cable tray width; and the cables shall be installed in a single layer.

(2) Where all of the cables are smaller than 4/0 AWG, the sum of the cross-sectional areas of all cables shall not exceed the maximum allowable cable fill area in Column 3 of Table 318-9, for the appropriate cable tray width.

(3) Where 4/0 AWG or larger cables are installed in the same cable tray with cables smaller than 4/0 AWG, the sum of the cross-sectional areas of all cables smaller than 4/0 AWG shall not exceed the maximum allowable fill area resulting from the computation in Column 4 of Table 318-9, for the appropriate cable tray width. The 4/0 AWG and larger cables shall be installed in a single layer and no other cables shall be placed on them.

**(d) Solid Bottom Cable Tray Multiconductor Control and/or Signal Cables Only.** Where a solid bottom cable tray, having a usable inside depth of 6 inches (152 mm) or less, contains multiconductor control and/or signal cables only, the sum of the cross-sectional areas of all cables at any cross-section shall not exceed 40 percent of the interior cross-sectional area of the cable tray. A depth of 6 inches (152 mm) shall be used to compute the allowable interior cross-sectional area of any cable tray which has a usable inside depth of more than 6 inches (152 mm).

**(e) Ventilated Channel Cable Trays.** Where ventilated channel cable trays contain multiconductor cables of any type, the combined cross-sectional area of all cables shall not exceed 1.3 square inches (839 sq mm) in 3-inch (76-mm) wide channel trays, 2.5 square inches (1613 sq mm) in 4-inch (102-mm) wide channel trays, or 3.8 square inches (2452 sq mm) in 6-inch (152-mm) wide channel trays.

*Exception: Where only one multiconductor cable is installed in a ventilated channel tray the cross-sectional area of the cable shall not exceed 2.3 square inches (1484 sq mm) in a 3-inch (76-mm) wide channel tray, 4.5 square inches (2903 sq mm) in a 4-inch (102-mm) wide channel tray, or 7.0 square inches (4516 sq mm) in a 6-inch (152-mm) wide channel tray.*

**Table 318-9. Allowable Cable Fill Area for Multiconductor Cables in Ladder, Ventilated Trough, or Solid Bottom Cable Trays for Cables Rated 2000 Volts or Less**

Inside Width of Cable Tray (Inches)	Maximum Allowable Fill Area in Square Inches for Multiconductor Cables			
	Ladder or Ventilated Trough Cable Trays, Section 318-9(a)		Solid Bottom Cable Trays, Section 318-9(c)	
	Column 1 Applicable for Section 318-9(a) (2) Only (Square Inches)	Column 2* Applicable for Section 318-9(a) (3) Only (Square Inches)	Column 3 Applicable for Section 318-9(c) (2) Only (Square Inches)	Column 4* Applicable for Section 318-9(c) (3) Only (Square Inches)
6	7	7—(1.2 Sd)**	5.5	5.5—Sd**
12	14	14—(1.2 Sd)	11.0	11.0—Sd
18	21	21—(1.2 Sd)	16.5	16.5—Sd
24	28	28—(1.2 Sd)	22.0	22.0—Sd
30	35	35—(1.2 Sd)	27.5	27.5—Sd
36	42	42—(1.2 Sd)	33.0	33.0—Sd

For SI units: one square inch = 645 square millimeters.

\* The maximum allowable fill areas in Columns 2 and 4 shall be computed. For example, the maximum allowable fill, in square inches, for a 6-inch (152-mm) wide cable tray in Column 2 shall be: 7 minus (1.2 multiplied by Sd).

\*\* The term Sd in Columns 2 and 4 is equal to the sum of the diameters, in inches, of all 4/0 AWG and larger multiconductor cables in the same cable tray with smaller cables.

**318-10. Number of Single Conductor Cables, Rated 2000 Volts or Less, in Cable Trays.** The number of single conductor cables, nominally rated 2000 volts or less, permitted in a single cable tray section shall not exceed the requirements of this section. The single conductors, or conductor assemblies, shall be evenly distributed across the cable tray. The conductor sizes herein apply to both aluminum and copper conductors.

(a) **Ladder or Ventilated Trough Cable Trays.** Where ladder or ventilated trough cable trays contain single conductor cables, the maximum number of single conductors shall conform to the following:

(1) Where all of the cables are 1000 MCM or larger, the sum of the diameters of all single conductor cables shall not exceed the cable tray width.

(2) Where all of the cables are smaller than 1000 MCM, the sum of the cross-sectional areas of all single conductor cables shall not exceed the maximum allowable cable fill area in Column 1 of Table 318-10, for the appropriate cable tray width.

(3) Where 1000 MCM or larger single conductor cables are installed in the same cable tray with single conductor cables smaller than 1000 MCM, the sum of the cross-sectional areas of all cables smaller than 1000 MCM shall not exceed the maximum allowable fill area resulting from the computation in Column 2 of Table 318-10, for the appropriate cable tray width.

(b) **Ventilated Channel-type Cable Trays.** Where 4-inch (102-mm) or 6-inch (152-mm) wide ventilated channel-type cable trays contain single conductor cables, the sum of the diameters of all single conductors shall not exceed the inside width of the channel.

**Table 318-10. Allowable Cable Fill Area for Single Conductor Cables in Ladder or Ventilated Trough Cable Trays for Cables Rated 2000 Volts or Less**

Inside Width of Cable Tray (Inches)	Maximum Allowable Fill Area in Square Inches for Single Conductor Cables in Ladder or Ventilated Trough Cable Trays	
	Column 1 Applicable for Section 318-10(a) (2) Only (Square Inches)	Column 2* Applicable for Section 318-10(a) (3) Only (Square Inches)
6	6.50	6.50—(1.1 Sd)**
12	13.0	13.0 —(1.1 Sd)
18	19.5	19.5 —(1.1 Sd)
24	26.0	26.0 —(1.1 Sd)
30	32.5	32.5 —(1.1 Sd)
36	39.0	39.0 —(1.1 Sd)

For SI units: one square inch = 645 square millimeters.

\* The maximum allowable fill areas in Column 2 shall be computed. For example, the maximum allowable fill, in square inches, for a 6-inch (152-mm) wide cable tray shall be: 6.5 minus (1.1 multiplied by Sd).

\*\* The term Sd in Column 2 is equal to the sum of the diameters, in inches, of all 1000 MCM and larger single conductor cables in the same ladder or ventilated trough cable tray with smaller cables.

**318-11. Ampacity of Cables Rated 2000 Volts or Less in Cable Trays.** The derating factors of Note 8 (a) to Tables 310-16 through 310-31 do not apply to the ampacity of cables in cable trays.

**(a) Multiconductor Cables.** The ampacity of multiconductor cables, nominally rated 2000 volts or less, installed according to the requirements of Section 318-9 shall comply with the allowable ampacities of Tables 310-18 and 310-22.

*Exception No. 1: Where cable trays are continuously covered for more than 6 feet (1.83 m) with solid unventilated covers, not over 95 percent of the allowable ampacities of Tables 310-22 and 310-31 shall be permitted for multiconductor cables.*

*Exception No. 2: Where multiconductor cables are installed in a single layer in uncovered trays, with a maintained spacing of not less than one cable diameter between cables, the ampacity shall not exceed the allowable ambient temperature corrected ampacities of Table 310-31.*

**(b) Single Conductor Cables.** The ampacity of single conductor cables, or single conductors cabled together (triplexed, quadruplexed, etc.), nominally rated 2000 volts or less, shall comply with the following:

(1) Where installed according to the requirements of Section 318-10, the ampacities for 600 MCM and larger single conductor cables in uncovered cable trays shall not exceed 75 percent of the allowable ampacities in Tables 310-17 and 310-19. Where cable trays are continuously covered for more than 6 feet (1.83 m) with solid unventilated covers, the ampacities for 600 MCM

and larger cables shall not exceed 70 percent of the allowable ampacities in Tables 310-17 and 310-19.

(2) Where installed according to the requirements of Section 318-10, the ampacities for 250 MCM through 500 MCM single conductor cables in uncovered cable trays shall not exceed 65 percent of the allowable ampacities in Tables 310-17 and 310-19. Where cable trays are continuously covered for more than 6 feet (1.83 m) with solid unventilated covers, the ampacities for 250 MCM through 500 MCM cables shall not exceed 60 percent of the allowable ampacities in Tables 310-17 and 310-19.

(3) Where single conductors are installed in a single layer in uncovered cable trays; with a maintained space of not less than one cable diameter between individual conductors, the ampacity of 250 MCM and larger cables shall not exceed the allowable ampacities in Tables 310-17 and 310-19.

(4) Where single conductors are installed in a triangular configuration in uncovered cable trays, with a maintained space of not less than 2.15 times one conductor diameter ( $2.15 \times \text{O.D.}$ ) between circuits, the ampacity of 250 MCM and larger cables shall not exceed the allowable ampacities in Table 310-23.

**318-12. Number of Type MV and Type MC Cables (2001 Volts or Over) in Cable Trays.** The number of cables, nominally rated 2001 volts or over, permitted in a single cable tray shall not exceed the requirements of this section.

The sum of the diameters of single conductor and multiconductor cables shall not exceed the cable tray width, and the cables shall be installed in a single layer. Where single conductor cables are triplexed, quadruplexed, or bound together in circuit groups, the sum of the diameters of the single conductors shall not exceed the cable tray width, and these groups shall be installed in single layer arrangement.

**318-13. Ampacity of Type MV and Type MC Cables (2001 Volts or Over) in Cable Trays.** The ampacity of cables, rated 2001 volts, nominal, or over, installed according to Section 318-12 shall not exceed the requirements of this section.

(a) **Multiconductor Cables (2001 Volts or Over).** The ampacity of multiconductor cables shall comply with the allowable ampacities of Tables 310-75 and 310-76.

*Exception No. 1: Where cable trays are continuously covered for more than 6 feet (1.83 m) with solid unventilated covers, not more than 95 percent of the allowable ampacities of Tables 310-75 and 310-76 shall be permitted for multiconductor cables.*

*Exception No. 2: Where multiconductor cables are installed in a single layer in uncovered cable trays, with a maintained spacing of not less than one cable diameter between cables, the ampacity shall not exceed the allowable ampacities of Tables 310-71 and 310-72.*

(b) **Single Conductor Cables (2001 Volts or Over).** The ampacity of single conductor cables, or single conductors cabled together (triplexed, quadruplexed, etc.), shall comply with the following:

(1) The ampacities for 250 MCM and larger single conductor cables in uncovered cable trays shall not exceed 75 percent of the allowable ampacities in Tables 310-69 and 310-70. Where the cable trays are covered for more than

6 feet (1.83 m) with solid unventilated covers, the ampacities for 250 MCM and larger single conductor cables shall not exceed 70 percent of the allowable ampacities in Tables 310-69 and 310-70.

(2) Where single conductor cables are installed in a single layer in uncovered cable trays, with a maintained space of not less than one cable diameter between individual conductors, the ampacity of 250 MCM and larger cables shall not exceed the allowable ampacities in Tables 310-69 and 310-70.

(3) Where single conductors are installed in a triangular configuration in uncovered cable trays, with a maintained space of not less than 2.15 times one conductor diameter ( $2.15 \times O.D.$ ) between circuits, the ampacity of 250 MCM and larger cables shall not exceed 105 percent of the allowable ampacities in Tables 310-71 and 310-72.

## ARTICLE 320 — OPEN WIRING ON INSULATORS

**320-1. Definition.** Open wiring on insulators is an exposed wiring method using cleats, knobs, tubes, and flexible tubing for the protection and support of single insulated conductors run in or on buildings, and not concealed by the building structure.

**320-2. Other Articles.** Open wiring on insulators shall comply with this article and also with the applicable provisions of other articles in this Code, especially Articles 225 and 300.

**320-3. Uses Permitted.** Open wiring on insulators shall be permitted on systems of 600 volts, nominal, or less, only for industrial or agricultural establishments, indoors or outdoors, in wet or dry locations, where subject to corrosive vapors, and for services.

### 320-5. Conductors.

(a) **Type.** Conductors shall be of a type specified by Article 310.

(b) **Ampacity.** The ampacity shall comply with Section 310-15.

**320-6. Conductor Supports.** Conductors shall be rigidly supported on noncombustible, nonabsorbent insulating materials and shall not contact any other objects. Supports shall be installed as follows: (1) within 6 inches (152 mm) from a tap or splice; (2) within 12 inches (305 mm) of a dead-end connection to a rosette, lampholder, or receptacle; (3) at intervals not exceeding 4 ½ feet (1.37 m) and at closer intervals sufficient to provide adequate support where likely to be disturbed.

*Exception No. 1: Supports for conductors No. 8 or larger installed across open spaces shall be permitted up to 15 feet (4.57 m) apart if noncombustible, nonabsorbent insulating spacers are used at least every 4 ½ feet (1.37 m) to maintain at least 2 ½ inches (64 mm) between conductors.*

*Exception No. 2: Where not likely to be disturbed in buildings of mill construction, No. 8 and larger conductors shall be permitted to be run across open spaces if supported from each wood cross member on approved insulators maintaining 6 inches (152 mm) between conductors.*

*Exception No. 3: In industrial establishments only, where conditions of maintenance and supervision assure that only qualified persons will service the system, conductors of size 250 MCM and larger shall be permitted to be run across open spaces where supported on intervals up to 30 feet (9.1 m) apart.*

**320-7. Mounting of Conductor Supports.** Where nails are used to mount knobs, they shall not be smaller than 10 penny. Where screws are used to mount knobs, or where nails or screws are used to mount cleats, they shall be of a length sufficient to penetrate the wood to a depth equal to at least one-half the height of the knob and fully the thickness of the cleat. Cushion washers shall be used with nails.

**320-8. Tie Wires.** No. 8 or larger conductors supported on solid knobs shall be securely tied thereto by tie wires having an insulation equivalent to that of the conductor.

**320-10. Flexible Nonmetallic Tubing.** In dry locations where not exposed to severe physical damage, conductors shall be permitted to be separately enclosed in flexible nonmetallic tubing. The tubing shall be in continuous lengths not exceeding 15 feet (4.57 m) and secured to the surface by straps at intervals not exceeding 4 ½ feet (1.37 m).

**320-11. Through Walls, Floors, Wood Cross Members, etc.** Open conductors shall be separated from contact with walls, floors, wood cross members, or partitions through which they pass by tubes or bushings of noncombustible, nonabsorbent insulating material. Where the bushing is shorter than the hole, a waterproof sleeve of noninductive material shall be inserted in the hole and an insulating bushing slipped into the sleeve at each end in such a manner as to keep the conductors absolutely out of contact with the sleeve. Each conductor shall be carried through a separate tube or sleeve.

(FPN): See Section 310-10 for temperature limitation of conductors.

**320-12. Clearance from Piping, Exposed Conductors, etc.** Open conductors shall be separated at least 2 inches (50.8 mm) from metal raceways, piping, or other conducting material, and from any exposed lighting, power, or signaling conductor, or shall be separated therefrom by a continuous and firmly fixed nonconductor in addition to the insulation of the conductor. Where any insulating tube is used, it shall be secured at the ends. Where practicable, conductors shall pass over rather than under any piping subject to leakage or accumulations of moisture.

**320-13. Entering Spaces Subject to Dampness, Wetness, or Corrosive Vapors.** Conductors entering or leaving locations subject to dampness, wetness, or corrosive vapors shall have drip loops formed on them and shall then pass upward and inward from the outside of the buildings, or from the damp, wet, or corrosive location; through noncombustible, nonabsorbent insulating tubes.

(FPN): See also Section 230-52.

**320-14. Protection from Physical Damage.** Conductors within 7 feet (2.13 m) from the floor shall be considered exposed to physical damage. Where open conductors cross ceiling joists and wall studs and are exposed to physical damage, they shall be protected by one of the following methods:



(1) by guard strips not less than  $\frac{7}{8}$  inch (22 mm) in thickness and at least as high as the insulating supports, placed on each side of and close to the wiring; (2) by a substantial running board at least  $\frac{1}{2}$  inch (12.7 mm) thick back of the conductors with side protections. Running boards shall extend at least 1 inch (25.4 mm) outside the conductors, but not more than 2 inches (50.8 mm), and the protecting sides shall be at least 2 inches (50.8 mm) high and at least  $\frac{7}{8}$  inch (22 mm) thick; (3) by boxing made as above and furnished with a cover kept at least 1 inch (25.4 mm) away from the conductors within. Where protecting vertical conductors on side walls, the boxing shall be closed at the top and the holes through which the conductors pass shall be bushed; (4) by rigid metal conduit, intermediate metal conduit, rigid nonmetallic conduit, or electrical metallic tubing, in which case the rules of Article 345, 346, 347, or 348 shall apply; or by metal piping, in which case the conductors shall be encased in continuous lengths of approved flexible tubing. The conductors passing through metal enclosures shall be so grouped that current in both directions is approximately equal.

**320-15. Unfinished Attics and Roof Spaces.** Conductors in unfinished attics and roof spaces shall comply with (a) or (b) below.

(a) **Accessible by Stairway or Permanent Ladder.** Conductors shall be installed along the side of or through bored holes in floor joists, studs, or rafters. Where run through bored holes, conductors in the joists and in studs or rafters to a height of not less than 7 feet (2.13 m) above the floor or floor joists shall be protected by substantial running boards extending not less than 1 inch (25.4 mm) on each side of the conductors. Running boards shall be securely fastened in place. Running boards and guard strips shall not be required for conductors installed along the sides of joists, studs, or rafters.

(b) **Not Accessible by Stairway or Permanent Ladder.** Conductors shall be installed along the sides of or through bored holes in floor joists, studs, or rafters.

*Exception: In buildings completed before wiring is installed and having head room at all points of less than 3 feet (914 mm).*

**320-16. Switches.** Surface-type snap switches shall be mounted in accordance with Section 380-10(a), and boxes shall not be required. Other type switches shall be installed in accordance with Section 380-4.

## ARTICLE 321 — MESSENGER SUPPORTED WIRING

**321-1. Definition.** Messenger supported wiring is an exposed wiring support system using a messenger wire to support insulated conductors by any one of the following: (1) a messenger with rings and saddles for conductor support; (2) a messenger with a field-installed lashing material for conductor support; (3) factory-assembled aerial cable; (4) multiplex cables utilizing a bare conductor, factory assembled and twisted with one or more insulated conductors, such as duplex, triplex, or quadruplex type of construction.

**321-2. Other Articles.** Messenger supported wiring shall comply with this article and also with the applicable provisions of other articles in this Code, especially Articles 225 and 300.

**321-3. Uses Permitted.**

(a) **Cable Types.** The following shall be permitted to be installed in messenger supported wiring under the conditions described in the article for each: (1) mineral-insulated, metal-sheathed cable (Article 330); (2) metal-clad cable (Article 334); (3) multiconductor service-entrance cable (Article 338); (4) multiconductor underground feeder and branch-circuit cable (Article 339); (5) power and control tray cable (Article 340); (6) power-limited tray cable (Section 725-40); (7) other factory-assembled, multiconductor control, signal, or power cables which are identified for the use.

(b) **In Industrial Establishments.** In industrial establishments only, where conditions of maintenance and supervision assure that only competent individuals will service the installed messenger supported wiring, the following shall be permitted:

(1) Any of the conductor types given in Table 310-13 or Table 310-62.

(2) MV Cable.

Where exposed to weather, conductors shall be listed for use in wet locations. Where exposed to direct rays of the sun, conductors or cables shall be sunlight-resistant.

(c) **Hazardous (Classified) Locations.** Messenger supported wiring shall be permitted to be used in hazardous (classified) locations where the contained cables are permitted for such use in Sections 501-4, 502-4, and 503-3.

**321-4. Uses Not Permitted.** Messenger supported wiring shall not be used in hoistways or where subject to severe physical damage.

**321-5. Ampacity.** The ampacity shall be determined by Section 310-15.

**321-6. Messenger Support.** The messenger shall be supported at dead ends and at intermediate locations so as to eliminate tension on the conductors. The conductors shall not be permitted to come into contact with the messenger supports or any structural members, walls, or pipes.

**321-7. Grounding.** The messenger shall be grounded as required by Sections 250-32 and 250-33 for enclosure grounding.

**321-8. Conductor Splices and Taps.** Conductor splices and taps made and insulated by approved methods shall be permitted in messenger supported wiring.

## ARTICLE 324 — CONCEALED KNOB-AND-TUBE WIRING

**324-1. Definition.** Concealed knob-and-tube wiring is a wiring method using knobs, tubes, and flexible nonmetallic tubing for the protection and support of single insulated conductors concealed in hollow spaces of walls and ceilings of buildings.

**324-2. Other Articles.** Concealed knob-and-tube wiring shall comply with this article and also with the applicable provisions of other articles in this Code, especially Article 300.

**324-3. Uses Permitted.** Concealed knob-and-tube wiring shall be permitted to be used only for extensions of existing installations and elsewhere only by special permission under the following conditions:

- (1) In the hollow spaces of walls and ceilings.
- (2) In unfinished attic and roof spaces as provided in Section 324-11.

**324-4. Uses Not Permitted.** Concealed knob-and-tube wiring shall not be used in commercial garages, theaters and similar locations, motion picture studios, hazardous (classified) locations or in the hollow spaces of walls, ceilings and attics when such spaces are insulated by loose or rolled insulating material.

**324-5. Conductors.**

(a) **Type.** Conductors shall be of a type specified by Article 310.

(b) **Ampacity.** The ampacity shall be determined by Section 310-15.

**324-6. Conductor Supports.** Conductors shall be rigidly supported on noncombustible, nonabsorbent insulating materials and shall not contact any other objects. Supports shall be installed as follows: (1) within 6 inches (152 mm) of each side of each tap or splice, and (2) at intervals not exceeding 4½ feet (1.37 m).

*Exception: If it is not practicable to provide supports in dry locations it shall be permissible to fish conductors through hollow spaces if each conductor is individually enclosed in flexible nonmetallic tubing. The tubing shall be in continuous lengths between supports, between boxes, or between a support and a box.*

**324-7. Tie Wires.** Where solid knobs are used, conductors shall be securely tied thereto by tie wires having insulation equivalent to that of the conductor.

**324-8. Conductor Clearances.** A clearance of not less than 3 inches (76 mm) shall be maintained between conductors and of not less than 1 inch (25.4 mm) between the conductor and the surface over which it passes.

*Exception: Where space is too limited to provide the above minimum clearances, such as at meters, panelboards, outlets, and switch points, the conductors shall be individually enclosed in flexible nonmetallic tubing, which shall be in continuous lengths between the last support or box and the terminal point.*

**324-9. Through Walls, Floors, Wood Cross Members, etc.** Conductors shall comply with Section 320-11 where passing through holes in structural members. Where passing through wood cross members in plastered partitions, conductors shall be protected by noncombustible, nonabsorbent, insulating tubes extending not less than 3 inches (76 mm) beyond the wood member.

**324-10. Clearance from Piping, Exposed Conductors, etc.** Conductors shall comply with Section 320-12 for clearances from other exposed conductors, piping, etc.

**324-11. Unfinished Attics and Roof Spaces.** Conductors in unfinished attics and roof spaces shall comply with (a) or (b) below.

(FPN): See Section 310-10 for temperature limitation of conductors.

**(a) Accessible by Stairway or Permanent Ladder.** Conductors shall be installed along the side of or through bored holes in floor joists, studs, or rafters. Where run through bored holes, conductors in the joists and in studs or rafters to a height of not less than 7 feet (2.13 m) above the floor or floor joists shall be protected by substantial running boards extending not less than 1 inch (25.4 mm) on each side of the conductors. Running boards shall be securely fastened in place. Running boards and guard strips shall not be required where conductors are installed along the sides of joists, studs, or rafters.

**(b) Not Accessible by Stairway or Permanent Ladder.** Conductors shall be installed along the sides of or through bored holes in floor joists, studs, or rafters.

*Exception: In buildings completed before wiring is installed and having head room at all points of less than 3 feet (914 mm).*

**324-12. Splices.** Splices shall be soldered unless approved splicing devices are used. In-line or strain splices shall not be used.

**324-13. Boxes.** Outlet boxes shall comply with Article 370.

**324-14. Switches.** Switches shall comply with Sections 380-4 and 380-10(b).

## ARTICLE 325 — INTEGRATED GAS SPACER CABLE

### Type IGS

Following the issuance of this edition an appeal was filed with respect to Sections 325-1 and 325-21 of this article — refer to page 70-iii.

#### A. General

**325-1. Definition.** Type IGS cable is a factory assembly of one or more conductors, each individually insulated and enclosed in a loose fit nonmetallic flexible conduit as an integrated gas spacer cable rated 0-600 volts.

**325-2. Other Articles.** The Type IGS cable shall comply with this article and also with the applicable provisions of other articles in this Code.

**325-3. Uses Permitted.** The Type IGS cable shall be permitted for use underground, including direct burial in the earth, as service-entrance conductors, or as feeder or branch-circuit conductors.

**325-4. Uses Not Permitted.** The Type IGS cable shall not be used as interior wiring or exposed in contact with buildings.

#### B. Installation

**325-11. Bending Radius.** Where the coilable nonmetallic conduit and cable is bent for installation purposes or is flexed or bent during shipment or installation, the radii of bends measured to the inside of the bend shall not be less than specified in Table 325-11.

**Table 325-11. Minimum Radii of Bends**

Conduit Trade Size	Minimum Radii
2 Inch	24 Inches (610 mm)
3 Inch	35 Inches (889 mm)
4 Inch	45 Inches (1.14 m)

**325-12. Bends.** A run of Type IGS cable between pull boxes or terminations shall not contain more than the equivalent of four quarter bends (360 degrees, total), including those bends located immediately at the pull box or terminations.

**325-13. Fittings.** Terminations and splices for the Type IGS cable shall be identified as a type which is suitable for maintaining the gas pressure within the conduit. A valve and cap shall be provided for each length of the cable and conduit to check the gas pressure or to inject gas into the conduit.

**325-14. Ampacity.** The ampacity of the Type IGS cable and conduit shall not exceed values shown in Table 325-14 for single conductor or multiconductor cable.

**Table 325-14. Ampacity Type IGS**

Size MCM	Amperes
250	119
500	168
750	206
1000	238
1250	266
1500	292
1750	315
2000	336
2250	357
2500	376
3000	412
3250	429
3500	445
3750	461
4000	476
4250	491
4500	505
4750	519

### C. Construction Specifications

**325-20. Conductors.** The conductors shall be solid aluminum rods, laid parallel, consisting of one to nineteen ½-inch (12.7-mm) diameter rods.

The minimum conductor size shall be 250 MCM and the maximum size shall be 4750 MCM.

**325-21. Insulation.** The insulation shall be dry kraft paper tapes and a pressurized sulfur hexafluoride gas (SF<sub>6</sub>), both approved for electrical use. The nominal gas pressure shall be 20 pounds per square inch gage (psig) (138 kPa gage).

The thickness of the paper spacer shall be as specified in Table 325-21.

**Table 325-21. Paper Spacer Thickness**

Size MCM	Thickness Inches (mm)
250-1000	.040 (1.02)
1250-4750	.060 (1.52)

**325-22. Conduit.** The conduit shall be an approved medium density polyethylene identified as suitable for use with natural gas rated pipe in 2 inches, 3 inches, 4 inches trade size. The percent fill dimensions for the conduit are given in Table 325-22.

The size of the conduit permitted for each conductor size shall be calculated for a percent fill not to exceed Table 1, Chapter 9.

**Table 325-22. Conduit Dimensions**

Conduit Trade Size, Inches	Outside Diameter, Inches (mm)	Inside Diameter, Inches (mm)
2	2.375 (60)	1.947 (49.46)
3	3.500 (89)	2.886 (73.30)
4	4.500 (114)	3.710 (94.23)

**325-23. Grounding.** The Type IGS cable shall comply with Article 250.

**325-24. Marking.** The provisions of Section 310-11, shall apply for the Type IGS cable.

## ARTICLE 326 — MEDIUM VOLTAGE CABLE

### Type MV

**326-1. Definition.** Type MV is a single or multiconductor solid dielectric insulated cable rated 2001 volts or higher.

**326-2. Other Articles.** In addition to the provisions of this article, Type MV cable shall comply with the applicable provisions of this Code, especially Articles 300, 305, 310, 318, 501, and 710.

**326-3. Uses Permitted.** Type MV cables shall be permitted for use on power systems rated up to 35,000 volts, nominal, in wet or dry locations, in

raceways, cable trays as specified in Section 318-3(b), or directly buried in accordance with Section 710-3(b) and in messenger supported wiring.

**326-4. Uses Not Permitted.** Type MV cable shall not be used unless identified for the use (1) where exposed to direct sunlight, and (2) in cable trays.

**326-5. Construction.** Type MV cables shall have copper, aluminum, or copper-clad aluminum conductors and shall be constructed in accordance with Article 310.

**326-6. Ampacity.** The ampacity of Type MV cable shall be in accordance with Section 310-15.

*Exception: The ampacity of Type MV cable installed in cable tray shall be in accordance with Section 318-13.*

**326-7. Marking.** Medium voltage cable shall be marked as required in Section 310-11.

## ARTICLE 328 — FLAT CONDUCTOR CABLE TYPE FCC

### A. General

**328-1. Scope.** This article covers a field-installed wiring system for branch circuits incorporating Type FCC cable and associated accessories as defined by the article. The wiring system is designed for installation under carpet squares.

#### 328-2. Definitions.

**Type FCC Cable.** Type FCC cable consists of three or more flat copper conductors placed edge-to-edge and separated and enclosed within an insulating assembly.

**FCC System.** A complete wiring system for branch circuits that is designed for installation under carpet squares. The FCC system includes Type FCC cable and associated shielding, connectors, terminators, adapters, boxes, and receptacles.

**Cable Connector.** A connector designed to join Type FCC cables without using a junction box.

**Insulating End.** An insulator designed to electrically insulate the end of a Type FCC cable.

**Top Shield.** A grounded metal shield covering undercarpet components of the FCC system for the purposes of providing protection against physical damage.

**Bottom Shield.** A protective layer which is installed between the floor and Type FCC flat conductor cable to protect the cable from physical damage and may or may not be incorporated as an integral part of the cable.

**Transition Assembly.** An assembly to facilitate connection of the FCC system to other approved wiring systems, incorporating (1) a means of

electrical interconnection, and (2) a suitable box or covering for providing electrical safety and protection against physical damage.

**Metal Shield Connections:** Means of connection designed to electrically and mechanically connect a metal shield to another metal shield, to a receptacle housing or self-contained device, or to a transition assembly.

**328-3. Other Articles.** The FCC systems shall conform with applicable provisions of Articles 210, 220, 240, 250 and 300.

**328-4. Uses Permitted.**

(a) **Branch Circuits.** Use of FCC systems shall be permitted both for general-purpose and appliance branch circuits, and for individual branch circuits.

(b) **Floors.** Use of FCC systems shall be permitted on hard, sound, smooth, continuous floor surfaces made of concrete, ceramic, or composition flooring, wood, and similar materials.

(c) **Walls.** Use of FCC systems shall be permitted on wall surfaces in surface metal raceways.

(d) **Damp Locations.** Use of FCC systems in damp locations shall be permitted.

(e) **Heated Floors.** Materials used for floors heated in excess of 30°C (86°F) shall be identified as suitable for use at these temperatures.

**328-5. Uses Not Permitted.** FCC systems shall not be used: (1) outdoors or in wet locations; (2) where subject to corrosive vapors; (3) in any hazardous (classified) location; or (4) in residential, school, and hospital buildings.

**328-6. Branch-Circuit Ratings.**

(a) **Voltage.** Voltage between ungrounded conductors shall not exceed 300 volts. Voltage between ungrounded conductors and grounded conductor shall not exceed 150 volts.

(b) **Current.** General-purpose and appliance branch circuits shall have ratings not exceeding 20 amperes. Individual branch circuits shall have ratings not exceeding 30 amperes.

## B. Installation

**328-10. Coverings.** Floor-mounted Type FCC cable, cable connectors, and insulating ends shall be covered with carpet squares no larger than 36 inches (914 mm) square. Those carpet squares that are adhered to the floor shall be attached with release-type adhesives.

**328-11. Cable Connections and Insulating Ends.** All Type FCC cable connections shall use connectors identified for their use, installed such that electrical continuity, insulation, and sealing against dampness and liquid spillage are provided. All bare cable ends shall be insulated and sealed against dampness and liquid spillage using listed insulating ends.

**328-12. Shields.**

(a) **Top Shield.** A metal top shield shall be installed over all floor-mounted Type FCC cable, connectors, and insulating ends. The top shield shall completely cover all cable runs, corners, connectors, and ends.



(b) **Bottom Shield:** A bottom shield shall be installed beneath all Type FCC cable, connectors, and insulating ends.

**328-13. Enclosure and Shield Connections:** All metal shields, boxes, receptacle housings, and self-contained devices shall be electrically continuous to the equipment grounding conductor of the supplying branch circuit. All such electrical connections shall be made with connectors identified for this use. The electrical resistivity of such shield system shall not be more than that of one conductor of the Type FCC cable used in the installation.

**328-14. Receptacles.** All receptacles, receptacle housings, and self-contained devices used with the FCC system shall be identified for this use and shall be connected to the Type FCC cable and metal shields. Connection from any grounding conductor of the Type FCC cable shall be made to the shield system at each receptacle.

**328-15. Connection to Other Systems:** Power feed, grounding connection, and shield system connection between the FCC system and other wiring systems shall be accomplished in a transition assembly identified for this use.

**328-16. Anchoring.** All FCC system components shall be firmly anchored to the floor or wall using an adhesive or mechanical anchoring system identified for this use. Floors shall be prepared to assure adherence of the FCC system to the floor until the carpet squares are placed.

**328-17. Crossings.** Crossings of two Type FCC cable runs shall be permitted. Crossings of a Type FCC cable over or under a flat telephone cable shall be permitted. In each case, a grounded layer of metal shielding shall separate the two cables.

**328-18. System Height.** Any portion of an FCC system with a height above floor level exceeding .090 inches (2.29 mm) shall be tapered or feathered at the edges to floor level.

**328-19. FCC Systems Alterations.** Alterations to FCC systems shall be permitted. New cable connectors shall be used at new connection points to make alterations. It shall be permitted to leave unused cable runs and associated cable connectors in place and energized. All cable ends shall be covered with insulating ends.

**328-20. Polarization of Connections.** All receptacles and connections shall be constructed and installed so as to maintain proper polarization of the system.

### C. Construction

**328-30. Type FCC Cable.** Type FCC cable shall be approved for use with the FCC system and shall consist of three, four, or five flat copper conductors, one of which shall be an equipment grounding conductor. The insulating material of the cable shall be moisture-resistant and flame-retardant.

**328-31. Markings.** Type FCC cable shall be clearly and durably marked on both sides at intervals of not more than 24 inches (610 mm), with the information required by Section 310-11(a) and with the following additional

information: (1) material of conductors; (2) maximum temperature rating; and (3) ampacity.

### **328-32. Conductor Identification.**

(a) **Colors.** Conductors shall be clearly and durably marked on both sides throughout their length as specified in Section 310-12.

(b) **Order.** For a two-wire FCC system with grounding, the grounding conductor shall be central.

**328-33. Corrosion Resistance.** Metal components of the system shall be either: (1) corrosion-resistant; (2) coated with corrosion-resistant materials; or (3) insulated from contact with corrosive substances.

**328-34. Insulation.** All insulating materials in the FCC systems shall be identified for their use.

### **328-35. Shields.**

(a) **Materials and Dimensions.** All top and bottom shields shall be of designs and materials identified for their use. Top shields shall be metal. Both metallic and nonmetallic materials shall be permitted for bottom shields.

(b) **Resistivity.** Metal shields have cross-sectional areas that provide for electrical resistivity of not more than that of one conductor of the Type FCC cable used in the installation.

(c) **Metal-Shield Connectors.** Metal shields shall be connected to each other and to boxes, receptacle housings, self-contained devices, and transition assemblies using metal-shield connectors.

**328-36. Receptacles and Housings.** Receptacle housings and self-contained devices designed either for floor mounting or for in- or on-wall mounting shall be permitted for use with the FCC system. Receptacle housings and self-contained devices shall incorporate means for facilitating entry and termination of Type FCC cable, and for electrically connecting the housing or device with the metal shield. Receptacles and self-contained devices shall comply with Section 210-7. Power and communications outlets installed together in common housing shall be permitted in accordance with Section 800-3(a)(2), Exception No. 1.

**328-37. Transition Assemblies.** All transition assemblies shall be identified for their use. Each assembly shall incorporate means for facilitating entry of the Type FCC cable into the assembly, for connecting the Type FCC cable to grounded conductors, and for electrically connecting the assembly to the metal cable shields and to equipment grounding conductors.

## ARTICLE 330 — MINERAL-INSULATED, METAL-SHEATHED CABLE

### Type MI

#### A. General

**330-1. Definition.** Type MI mineral-insulated, metal-sheathed cable is a factory assembly of one or more conductors insulated with a highly compressed refractory mineral insulation and enclosed in a liquidtight and gastight continuous copper sheath.

**330-2. Other Articles.** Type MI cable shall comply with this article and also with the applicable provisions of other articles in this Code, especially Article 300.

**330-3. Uses Permitted.** Type MI cable shall be permitted as follows: (1) for services, feeders, and branch circuits; (2) in dry, wet; or continuously moist locations; (3) indoors or outdoors; (4) where exposed or concealed; (5) embedded in plaster, concrete, fill or other masonry, whether above or below grade; (6) in any hazardous (classified) location; (7) where exposed to oil and gasoline; (8) where exposed to corrosive conditions not deteriorating to its sheath; (9) in underground runs where suitably protected against physical damage and corrosive conditions.

**330-4. Uses Not Permitted.** Type MI cable shall not be used where exposed to destructive corrosive conditions:

*Exception: Where protected by materials suitable for the conditions.*

#### B. Installation

**330-10. Wet Locations.** Where installed in wet locations, Type MI cable shall comply with Section 300-6(c).

**330-11. Through Joists, Studs, or Rafters.** Type MI cable shall comply with Section 300-4 where installed through studs, joists, rafters, or similar wood members.

**330-12. Supports.** Type MI cable shall be securely supported at intervals not exceeding 6 feet (1.83 m) by straps, staples, hangers, or similar fittings so designed and installed as not to damage the cable:

*Exception: Where cable is fished in.*

**330-13. Bends.** Bends in Type MI cable shall be so made as not to damage the cable. The radius of the inner edge of any bend shall not be less than five times the cable diameter.

**330-14. Fittings.** Fittings used for connecting Type MI cable to boxes, cabinets, or other equipment shall be identified for such use. Where single-conductor cables enter ferrous metal boxes or cabinets, the installation shall comply with Section 300-20 to prevent inductive heating.

**330-15. Terminal Seals.** Where Type MI cable terminates, an approved seal shall be provided immediately after stripping to prevent the entrance of moisture into the insulation. The conductors extending beyond the sheath shall be individually provided with an approved insulating material.

### C. Construction Specifications

**330-20. Conductors.** Type MI cable conductors shall be of solid copper with a cross-sectional area corresponding to standard AWG sizes.

**330-21. Insulation.** The conductor insulation in Type MI cable shall be a highly compressed refractory mineral that will provide proper spacing for the conductors.

**330-22. Outer Sheath.** The outer sheath shall be of a continuous copper construction to provide mechanical protection, a moisture seal, and an adequate path for grounding purposes.

## ARTICLE 331 — ELECTRICAL NONMETALLIC TUBING

Following the issuance of this edition an appeal was filed with respect to Sections 331-3 and 331-4 of this article — refer to page 70-iii.

### A. General

**331-1. Definition.** Electrical nonmetallic tubing is a pliable corrugated raceway of circular cross-section with integral or associated couplings, connectors and fittings listed for the installation of electric conductors. It is composed of a material that is resistant to moisture, chemical atmospheres, and is flame-retardant.

A pliable raceway is a raceway which can be bent by hand with a reasonable force, but without other assistance.

**331-2. Other Articles.** Installations for electrical nonmetallic tubing shall comply with the provisions of the applicable sections of Article 300. Where equipment grounding is required by Article 250, a separate equipment grounding conductor shall be installed in the raceway.

**331-3. Uses Permitted.** The use of electrical nonmetallic tubing and fittings shall be permitted:

(1) Concealed within walls, floors, and ceilings where the walls, floors, and ceilings provide a thermal barrier of material which has at least a 15-minute finish rating as identified in listings of fire-rated assemblies.

(2) In locations subject to severe corrosive influences as covered in Section 300-6 and where subject to chemicals for which the materials are specifically approved.

(3) In concealed, dry, and damp locations not prohibited by Section 331-4.

(4) Above suspended ceilings where the suspended ceilings provide a thermal barrier of material which has at least a 15-minute finish rating as identified in listings of fire-rated assemblies.

(5) Embedded in poured concrete, provided fittings identified for this purpose are used for connections.

(FPN): Extreme cold may cause some types of nonmetallic conduits to become brittle and, therefore, more susceptible to damage from physical contact.

**331-4. Uses Not Permitted.** Electrical nonmetallic tubing shall not be used:

- (1) In hazardous (classified) locations.
- (2) For the support of fixtures and other equipment.
- (3) Where subject to ambient temperatures exceeding those for which the tubing is approved.
- (4) For conductors whose insulation temperature limitations would exceed those for which the tubing is listed.
- (5) For direct earth burial.
- (6) Where the voltage is over 600 volts.
- (7) In exposed locations except as permitted by Section 331-3(4).

## B. Installation

### 331-5. Size.

(a) **Minimum.** Tubing smaller than ½-inch electrical trade size shall not be used.

(b) **Maximum.** Tubing larger than 1-inch electrical trade size shall not be used.

**331-6. Number of Conductors in Tubing.** The number of conductors in a single tubing shall not exceed that permitted by the percentage fill in Table 1, Chapter 9.

**331-7. Trimming.** All cut ends of tubing shall be trimmed inside and outside to remove rough edges.

**331-8. Joints.** All joints between lengths of tubing and between tubing and couplings, fittings and boxes shall be by an approved method.

**331-9. Bends — How Made.** Bends of electrical nonmetallic tubing shall be so made that the tubing will not be damaged and that the internal diameter of the tubing will not be effectively reduced. Bends shall be permitted to be made manually without auxiliary equipment and the radius of the curve of the inner edge of such bends shall not be less than shown in Table 346-10.

**331-10. Bends — Number in One Run.** A run of tubing between outlet and outlet or outlet and fitting shall not contain more than the equivalent of four quarter bends (360 degrees, total) including those bends located immediately at the outlet or fitting.

**331-11. Supports.** Electrical nonmetallic tubing shall be installed as a complete system as provided in Article 300 and shall be securely fastened in place. Tubing shall be firmly fastened within 3 feet (914 mm) of each outlet

box, junction box, cabinet or fitting. Tubing shall be secured at least every 3 feet (914 mm).

**331-12. Boxes and Fittings.** Boxes and fittings shall comply with the applicable provisions of Article 370.

**331-13. Splices and Taps.** Splices and taps shall be made only in junction boxes, outlet boxes or conduit bodies. See Article 370.

**331-14. Bushings.** Where a tubing enters a box or other fitting, a bushing or adapter shall be provided to protect the wire from abrasion unless the design of the box or fitting is such as to provide equivalent protection.

(FPN): See Section 373-6(c) for the protection of conductors No. 4 AWG or larger.

### C. Construction Specifications

**331-15. General.** Electrical nonmetallic tubing shall be clearly and durably marked at least every 10 feet (3.05 m) as required in the first sentence of Section 110-21. The type of material shall also be included in the marking.

## ARTICLE 333 — ARMORED CABLE

### Type AC Cable

**333-1. Definition.** Type AC cable is a fabricated assembly of insulated conductors in a flexible metallic enclosure. See Section 333-4.

**333-2. Other Articles.** Type AC cable shall comply with this article and also with the applicable provisions of other articles in this Code, especially Article 300.

**333-3. Marking.** The provisions of Section 310-11 shall apply, except that Type AC cable shall have ready identification of the maker by distinctive external markers on the cable sheath throughout its entire length.

**333-4. Construction.** Type AC cable shall be an approved cable with acceptable metal covering. The insulated conductors shall conform with Section 333-5.

Type AC cables are branch-circuit and feeder cables with armor of flexible metal tape. Cables of the AC type, except ACL, shall have an internal bonding strip of copper or aluminum, in intimate contact with the armor for its entire length.

**333-5. Conductors.** Insulated conductors shall be of a type listed in Table 310-13 or ones which are identified for use in this cable. In addition, the conductors shall have an overall moisture-resistant and fire-retardant fibrous covering. For Type ACT, a moisture-resistant fibrous covering shall be required only on the individual conductors. The ampacity shall be determined by Section 310-15.

*Exception: Armored cable installed in thermal insulation shall have conductors rated at 90°C (194°F). The ampacity of cable installed in these applications shall be that of 60°C (140°F) conductors.*

### **333-6. Use.**

**(a) Uses Permitted.** Except where otherwise specified elsewhere in this Code, and where not subject to physical damage, Type AC cable shall be permitted for branch circuits and feeders in both exposed and concealed work.

Type AC cable shall be permitted in dry locations; for underplaster extensions as provided in Article 344; and embedded in plaster finish on brick or other masonry, except in damp or wet locations. It shall be permissible to run or fish this cable in the air voids of masonry block or tile walls; where such walls are exposed or subject to excessive moisture or dampness or are below grade line, Type ACL cable shall be used. This cable shall contain lead-covered conductors (Type ACL) if used where exposed to the weather or to continuous moisture; for underground runs in raceways; where embedded in masonry, concrete, or fill in buildings in course of construction; or where exposed to oil, or other conditions having a deteriorating effect on the insulation.

**(b) Uses Not Permitted.** Type AC cable shall not be used where prohibited elsewhere in this Code, including (1) in theaters and similar locations, except as provided in Article 518, Places of Assembly; (2) in motion picture studios; (3) in any hazardous (classified) locations; (4) where exposed to corrosive fumes or vapors; (5) on cranes or hoists, except as provided in Section 610-11, Exception No. 3; (6) in storage battery rooms; (7) in hoistways or on elevators, except as provided in Section 620-21; or (8) in commercial garages where prohibited in Article 511.

*Exception: See Section 501-4(b), Exception.*

Type ACL cable shall not be used for direct burial in the earth.

**333-7. Supports.** Type AC cable shall be secured by approved staples, straps, hangers, or similar fittings so designed and installed as not to damage the cable at intervals not exceeding 4 ½ feet (1.37 m) and within 12 inches (305 mm) from every outlet box, junction box, cabinet, or fitting.

*Exception No. 1: Where cable is fished.*

*Exception No. 2: Lengths of not more than 2 feet (610 mm) at terminals where flexibility is necessary.*

*Exception No. 3: Lengths of not more than 6 feet (1.83 m) from an outlet for connections within an accessible ceiling to lighting fixtures or equipment.*

**333-8. Bends.** All bends shall be made so that the cable will not be damaged, and the radius of the curve of the inner edge of any bend shall not be less than five times the diameter of the Type AC cable.

**333-9. Boxes and Fittings.** At all points where the armor of AC cable terminates, a fitting shall be provided to protect wires from abrasion, unless the design of the outlet boxes or fittings is such as to afford equivalent protection, and, in addition, an approved insulating bushing or its equivalent approved protection shall be provided between the conductors and the armor. The connector or clamp by which the Type AC cable is fastened to boxes or cabinets shall be of such design that the insulating bushing or its

equivalent will be visible for inspection. This bushing shall not be required with lead-covered cables where so installed that the lead sheath will be visible for inspection. Where change is made from Type AC cable to other cable or raceway wiring methods, a box, fitting or conduit body shall be installed at junction points as required in Section 300-15.

**333-10. Through Studs, Joists, and Rafters.** Type AC cable shall comply with Section 300-4 where installed through studs, joists, rafters, or similar wood members.

**333-11. Exposed Work.** Exposed runs of cable shall closely follow the surface of the building finish or of running boards.

*Exception No. 1: Lengths of not more than 24 inches (610 mm) at terminals where flexibility is necessary.*

*Exception No. 2: On the underside of floor joists in basements where supported at each joist and so located as not to be subject to physical damage.*

**333-12. In Accessible Attics.** Type AC cables in accessible attics or roof spaces shall be installed as specified in (a) and (b) below.

**(a) Where Run Across the Top of Floor Joists.** Where run across the top of floor joists, or within 7 feet (2.13 m) of floor or floor joists across the face of rafters or studding, in attics and roof spaces which are accessible, the cable shall be protected by substantial guard strips which are at least as high as the cable. Where this space is not accessible by permanent stairs or ladders, protection shall only be required within 6 feet (1.83 m) of the nearest edge of the scuttle hole or attic entrance.

**(b) Where Carried Along the Sides of Floor Joists.** Where cable is carried along the sides of rafters, studs, or floor joists, neither guard strips nor running boards shall be required.

## ARTICLE 334 — METAL-CLAD CABLE

### A. General

**334-1. Definition.** Type MC cable is a factory assembly of one or more conductors, each individually insulated and enclosed in a metallic sheath of interlocking tape, or a smooth or corrugated tube.

**334-2. Other Articles.** Metal-clad cable shall comply with this article and also with the applicable provisions of other articles in this Code, especially Article 300.

Type MC cable shall be permitted for systems in excess of 600 volts, nominal. See Section 300-2(a).

**334-3. Uses Permitted.** Except where otherwise specified in this Code and where not subject to physical damage, Type MC cables shall be permitted as follows: (1) for services, feeders, and branch circuits; (2) for power, lighting, control, and signal circuits; (3) indoors or outdoors; (4) where exposed or concealed; (5) direct buried when identified for such use; (6) in cable tray;



(7) in any approved raceway; (8) as open runs of cable; (9) as aerial cable on a messenger; (10) in hazardous (classified) locations as permitted in Articles 501, 502, and 503; (11) in dry locations; and (12) in wet locations when any of the following conditions are met:

(1) The metallic covering is impervious to moisture.

(2) A lead sheath or moisture impervious jacket is provided under the metal covering.

(3) The insulated conductors under the metallic covering are approved for use in wet locations.

*Exception: See Section 501-4(b), Exception.*

(FPN): See Section 300-6 for protection against corrosion.

**334-4. Uses Not Permitted.** Type MC cable shall not be used where exposed to destructive corrosive conditions, such as direct burial in the earth, in concrete, or where exposed to cinder fills, strong chlorides, caustic alkalis, or vapors of chlorine or of hydrochloric acids.

*Exception: Where the metallic sheath is suitable for the conditions or is protected by material suitable for the conditions.*

## B. Installation

**334-10. Installation.** Type MC cable shall be installed in compliance with Articles 300, 710, and 725 as applicable.

(a) **Support.** Type MC cable shall be supported and secured at intervals not exceeding 6 feet (1.83 m).

(b) **Cable Tray.** Type MC cable installed in cable tray shall comply with Article 318.

(c) **Direct Buried.** Direct buried cable shall comply with Section 300-5 or 710-3, as appropriate.

(d) **Installed as Service-Entrance Cable.** Type MC cable installed as service-entrance cable shall comply with Article 230.

(e) **Installed Outside of Buildings or as Aerial Cable.** Type MC cable installed outside of buildings or as aerial cable shall comply with Article 225 and Article 321.

**334-11. Bending Radius.** All bends shall be so made that the cable will not be damaged, and the radius of the curve of the inner edge of any bend shall not be less than shown below.

(a) **Smooth Sheath.**

(1) Ten times the external diameter of the metallic sheath for cable not more than  $\frac{3}{4}$  inch (19 mm) in external diameter;

(2) Twelve times the external diameter of the metallic sheath for cable more than  $\frac{3}{4}$  inch (19 mm) but not more than  $1\frac{1}{2}$  inches (38 mm) in external diameter; and

(3) Fifteen times the external diameter of the metallic sheath for cable more than  $1\frac{1}{2}$  inches (38 mm) in external diameter.

(b) **Interlocked-type Armor or Corrugated Sheath.** Seven times the external diameter of the metallic sheath.

(c) **Shielded Conductors.** Twelve times the overall diameter of one of the individual conductors or seven times the overall diameter of the multiconductor cable, whichever is greater.

**334-12. Fittings.** Fittings used for connecting Type MC cable to boxes, cabinets, or other equipment shall be identified for such use. Where single-conductor cables enter ferrous metal boxes or cabinets, the installation shall comply with Section 300-20 to prevent inductive heating.

**334-13. Ampacity.** The ampacity of Type MC cable shall be in accordance with Section 310-15.

*Exception: The ampacities for Type MC cable installed in cable tray shall be determined in accordance with Sections 318-11 and 318-13.*

(FPN): See Section 310-10 for temperature limitation of conductors.

### C. Construction Specifications

**334-20. Conductors.** The conductors shall be of copper, aluminum, or copper-clad aluminum, solid or stranded.

The minimum conductor size shall be No. 18 copper and No. 12 aluminum or copper-clad aluminum.

**334-21. Insulation.** The insulated conductors shall comply with (a) or (b) below.

(a) **600 Volts.** Insulated conductors in sizes No. 18 and 16 shall be of a type listed in Table 402-3, with a maximum operating temperature not less than 90°C (194°F), and as permitted by Section 725-16. Conductors larger than No. 16 shall be of a type listed in Table 310-13 or of a type identified for use in MC cable.

(b) **Over 600 Volts.** Insulated conductors shall be of a type listed in Tables 310-61 through 310-67.

**334-22. Metallic Sheath.** The metallic covering shall be one of the following types: smooth metallic sheath, welded and corrugated metallic sheath, interlocking metal tape armor. The metallic sheath shall be continuous and close fitting.

Supplemental protection of an outer covering of corrosion-resistant material shall be permitted, and shall be required where such protection is needed. The sheath shall not be used as a current-carrying conductor.

(FPN): See Section 300-6 for protection against corrosion.

**334-23. Grounding.** Type MC cable shall provide an adequate path for equipment grounding as required by Article 250.

**334-24. Marking.** The provisions of Section 310-11 shall apply.

**ARTICLE 336 — NONMETALLIC-SHEATHED CABLE****Types NM and NMC****A. General**

**336-1. Definition.** Nonmetallic-sheathed cable is a factory assembly of two or more insulated conductors having an outer sheath of moisture-resistant, flame-retardant, nonmetallic material.

**336-2. Other Articles.** In addition to the provisions of this article, installations of nonmetallic-sheathed cable shall comply with the other applicable provisions of this Code, especially Articles 300 and 310.

**336-3. Uses Permitted.** Type NM and Type NMC cables shall be permitted to be used in one- and two-family dwellings, multifamily dwellings and other structures, except as prohibited in Section 336-4.

(FPN): See Section 310-10 for temperature limitation of conductors.

(a) **Type NM.** Type NM cable shall be permitted for both exposed and concealed work in normally dry locations. It shall be permissible to install or fish Type NM cable in air voids in masonry block or tile walls where such walls are not exposed or subject to excessive moisture or dampness.

(b) **Type NMC.** Type NMC cable shall be permitted: (1) for both exposed and concealed work in dry, moist, damp, or corrosive locations; (2) in outside and inside walls of masonry block or tile; (3) in a shallow chase in masonry, concrete, or adobe and covered with plaster, adobe, or similar finish.

**336-4. Uses Not Permitted.**

(a) **Type NM or NMC.** Types NM and NMC cables shall not be used: (1) in any dwelling or structure exceeding three floors above grade; (2) as service-entrance cable; (3) in commercial garages having hazardous (classified) locations as provided in Section 511-2; (4) in theaters and similar locations, except as provided in Article 518, Places of Assembly; (5) in motion picture studios; (6) in storage battery rooms; (7) in hoistways; (8) embedded in poured cement, concrete, or aggregate; or (9) in any hazardous (classified) location except as permitted by Section 501-4(b), Exception. For the purpose of this article, the first floor of a building shall be that floor which is designed for human habitation and which has 50 percent or more of its perimeter level with or above finished grade of the exterior wall line.

(b) **Type NM.** Type NM cable shall not be installed: (1) where exposed to corrosive fumes or vapors; (2) where embedded in masonry, concrete, adobe, fill, or plaster; (3) in a shallow chase in masonry, concrete, or adobe and covered with plaster, adobe, or similar finish.

**B. Installation**

**336-10. Exposed Work — General.** In exposed work, except as provided in Sections 336-12 and 336-13, the cable shall be installed as specified in (a) and (b) below.

(a) **To Follow Surface.** The cable shall closely follow the surface of the building finish or of running boards.

**(b) Protection from Physical Damage.** The cable shall be protected from physical damage where necessary by conduit, electrical metallic tubing, pipe, guard strips, or other means. Where passing through a floor the cable shall be enclosed in rigid metal conduit, intermediate metal conduit, electrical metallic tubing, or other metal pipe extending at least 6 inches (152 mm) above the floor.

**336-11. Through Studs, Joists, and Rafters.** The cable shall comply with Section 300-4 where installed through studs, joists, rafters, and similar members.

**336-12. In Unfinished Basements.** Where the cable is run at angles with joists in unfinished basements, it shall be permissible to secure cables not smaller than two No. 6 or three No. 8 conductors directly to the lower edges of the joists. Smaller cables shall either be run through bored holes in joists or on running boards. Where run parallel to the joists, cable of any size shall be secured to the sides or faces of the joists.

**336-13. In Accessible Attics.** The installation of cable in accessible attics or roof spaces shall also comply with Section 333-12.

**336-14. Bends.** Bends in cable shall be so made, and other handling shall be such, that the protective coverings of the cable will not be damaged, and no bend shall have a radius less than five times the diameter of the cable.

**336-15. Supports.** Nonmetallic-sheathed cable shall be secured by staples, straps, or similar fittings so designed and installed as not to damage the cable. Cable shall be secured in place at intervals not exceeding 4½ feet (1.37 m) and within 12 inches (305 mm) from every cabinet, box, or fitting.

*Exception No. 1: For concealed work in finished buildings, or finished panels for prefabricated buildings where such supporting is impracticable, it shall be permissible to fish the cable between access points.*

*Exception No. 2: A wiring device identified for the use, without a separate outlet box, incorporating an integral cable clamp shall be permitted when the cable is secured in place at intervals not exceeding 4½ feet (1.37 m) and within 12 inches (305 mm) from the wiring device wall opening, and there shall be at least a 12-inch (305-mm) loop of unbroken cable or 6 inches (152 mm) of a cable end available on the interior side of the finished wall to permit replacement.*

**336-16. Devices of Insulating Material.** Switch, outlet, and tap devices of insulating material shall be permitted to be used without boxes in exposed cable wiring, and for rewiring in existing buildings where the cable is concealed and fished. Openings in such devices shall form a close fit around the outer covering of the cable, and the device shall fully enclose that part of the cable from which any part of the covering has been removed.

Where connections to conductors are by binding-screw terminals, there shall be available as many terminals as conductors.

*Exception: Where cables are clamped within the structure, and terminals are of a type identified for use with multiconductors.*

**336-17. Boxes of Insulating Material.** Nonmetallic outlet boxes shall be permitted as provided in Section 370-3.

**336-18. Devices with Integral Enclosures.** Wiring devices with integral enclosures identified for such use shall be permitted as provided in Section 300-15(b), Exception No. 5.

### C. Construction Specifications

**336-25. Construction.** The insulated conductors of Type NM and NMC cable shall be in conformity with Section 336-26. The conductors shall be sizes No. 14 through 2 with copper conductors or sizes No. 12 through 2 with aluminum or copper-clad aluminum conductors. In addition to the insulated conductors, the cable shall be permitted to have an insulated or bare conductor for equipment grounding purposes only. When provided, the grounding conductor shall be sized in accordance with Article 250.

(a) **Type NM.** The overall covering shall be flame-retardant and moisture-resistant.

(b) **Type NMC.** The overall covering shall be flame-retardant, moisture-resistant, fungus-resistant, and corrosion-resistant.

**336-26. Conductors.** The insulated conductors shall be one of the types listed in Table 310-13 which is suitable for branch-circuit wiring or one which is identified for use in these cables.

Conductors shall be rated at 90°C (194°F). The ampacity of Types NM and NMC cable shall be that of 60°C (140°F) conductors and shall comply with Section 310-15.

**336-27. Marking.** In addition to the provisions of Section 310-11, the cable shall have a distinctive marking on the exterior for its entire length specifying the cable type.

## ARTICLE 337 — SHIELDED NONMETALLIC-SHEATHED CABLE

### Type SNM

**337-1. Definition.** Type SNM shielded nonmetallic-sheathed cable is a factory assembly of two or more insulated conductors in an extruded core of moisture-resistant, flame-resistant nonmetallic material, covered with an overlapping spiral-metal tape and wire shield and jacketed with an extruded moisture-, flame-, oil-, corrosion-, fungus-, and sunlight-resistant nonmetallic material.

**337-2. Other Articles.** In addition to the provisions of this article, installation of Type SNM cable shall conform to other applicable provisions, such as Articles 300, 318, 501, and 502.

**337-3. Uses Permitted.** Type SNM cable shall be used only as follows: (1) where operating temperatures do not exceed the rating marked on the cable; (2) in cable trays or in raceways; or (3) in hazardous (classified) locations where permitted in Articles 500 through 516.

(FPN): See Section 310-10 for temperature limitation of conductors.

**337-4. Bends.** Bends in Type SNM cable shall be so made as not to damage the cable or its covering. The radius of the inner edge shall not be less than five times the cable diameter.

**337-5. Handling.** Type SNM cable shall be handled in such a manner as not to damage the cable or its covering.

**337-6. Fittings.** Fittings for connecting Type SNM cable to enclosures or equipment shall be identified for this use.

**337-7. Bonding.** The wire shield shall be bonded to the frame or enclosure of the utilization equipment and to the ground bus or connection at the power supply point. This bonding shall be accomplished using fittings (Section 337-6) or by other Code-approved bonding methods [Section 501-16(a)].

**337-8. Constructions.** The conductors of Type SNM cable shall be Type TFN, TFFN, THHN or THWN in sizes No. 18 through No. 2 copper and No. 12 through No. 2 in aluminum or copper-clad aluminum. Conductor sizes may be mixed in individual cables. The flat overlapping metal tapes shall be spiraled with a long lay. The shield wires shall have a total cross-sectional area as required by Article 250 and not less than the largest circuit conductor in the cable.

The outer jacket shall be water-, oil-, flame-, corrosion-, fungus-, and sunlight-resistant, and suitable for installation in cable trays.

**337-9. Marking.** Type SNM cable shall have a distinctive marking on its exterior surface for its entire length indicating its type and maximum operating temperature. It shall comply with the general marking requirements of Section 310-11.

The conductors shall each be numbered for identification from each other by durable marking on two sides 180 degrees apart every 6 inches (152 mm) of length, with alternate legends inverted to facilitate reading from both sides.

## ARTICLE 338 — SERVICE-ENTRANCE CABLE

### Types SE and USE

**338-1. Definition.** Service-entrance cable is a single conductor or multiconductor assembly provided with or without an overall covering; primarily used for services and of the following types:

(a) **Type SE.** Type SE, having a flame-retardant, moisture-resistant covering.

(b) **Type USE.** Type USE, identified for underground use, having a moisture-resistant covering, but not required to have a flame-retardant covering.

Cabled single-conductor Type USE constructions recognized for underground use may have a bare copper conductor cabled with the assembly. Type USE single, parallel, or cabled conductor assemblies recognized for underground use may have a bare copper concentric conductor applied. These constructions do not require an outer overall covering.

(FPN): See Section 230-41, Exception b.

(c) **One Uninsulated Conductor.** If Type SE or USE cable consists of two or more conductors, one shall be permitted to be uninsulated.

**338-2. Uses Permitted as Service-Entrance Conductors.** Service-entrance cable used as service-entrance conductors shall be installed as required by Article 230.

**338-3. Uses Permitted as Branch Circuits or Feeders.**

(a) **Grounded Conductor Insulated.** Type SE service-entrance cables shall be permitted in interior wiring systems where all of the circuit conductors of the cable are of the rubber-covered or thermoplastic type.

(b) **Grounded Conductor Not Insulated.** Type SE service-entrance cables without individual insulation on the grounded circuit conductor shall not be used as a branch circuit or as a feeder within a building, except a cable that has a final nonmetallic outer covering and is supplied by alternating current at not over 150 volts to ground shall be permitted: (1) as a branch circuit to supply only a range, wall-mounted oven, counter-mounted cooking unit, or clothes dryer as covered in Section 250-60, or (2) as a feeder to supply only other buildings on the same premises.

Type SE service-entrance cable shall be permitted for interior use where the fully insulated conductors are used for circuit wiring and the uninsulated conductor is used for equipment grounding purposes.

(c) **Temperature Limitations.** Type SE service-entrance cable used to supply appliances shall not be subject to conductor temperatures in excess of the temperature specified for the type of insulation involved.

**338-4. Installation Methods.**

(a) **Interior Wiring.** In addition to the provisions of this article, Type SE service-entrance cable used for interior wiring shall comply with the applicable provisions of Article 300.

(b) **Unarmored Cable.** Unarmored cable shall be installed in accordance with the provisions of Article 336.

(c) **Through Studs, Joists, Rafters, or Similar Members.** Cables shall comply with Section 300-4 where installed through studs, joists, rafters, or similar members.

(FPN): See Section 310-10 for temperature limitation of conductors.

**338-5. Marking.** Service-entrance cable shall be marked as required in Section 310-11. Cable with the neutral conductor smaller than the ungrounded conductors shall be so marked.

## ARTICLE 339 — UNDERGROUND FEEDER AND BRANCH-CIRCUIT CABLE

### Type UF

**339-1. Description and Marking.**

(a) **Description.** Underground feeder and branch-circuit cable shall be an approved Type UF cable in sizes No. 14 copper or No. 12 aluminum or

copper-clad aluminum through No. 4/0. The conductors of Type UF shall be one of the moisture-resistant types listed in Table 310-13 which is suitable for branch-circuit wiring or one which is identified for such use. In addition to the insulated conductors, the cable shall be permitted to have an approved size of insulated or bare conductor for equipment grounding purposes only. The overall covering shall be flame-retardant, moisture-, fungus-, and corrosion-resistant, and suitable for direct burial in the earth.

(b) **Marking.** In addition to the provisions of Section 310-11, the cable shall have a distinctive marking on the exterior for its entire length specifying the cable type.

**339-2. Other Articles.** In addition to the provisions of this article, installations of underground feeder and branch-circuit cable (Type UF) shall comply with other applicable provisions of this Code, especially Article 300 and Section 310-13.

### **339-3. Use.**

#### **(a) Uses Permitted.**

(1) Type UF cable shall be permitted for use underground, including direct burial in the earth, as feeder or branch-circuit cable where provided with overcurrent protection of the rated ampacity as required in Section 339-4.

(2) Where single-conductor cables are installed, all cables of the feeder circuit, subfeeder circuit, or branch circuit, including the neutral conductor, if any, shall be run together in the same trench or raceway.

*Exception: For solar photovoltaic systems in accordance with Section 690-31.*

(3) For underground requirements, see Section 300-5.

(4) Type UF cable shall be permitted for interior wiring in wet, dry, or corrosive locations under the recognized wiring methods of this Code, and where installed as nonmetallic-sheathed cable, the installation and conductor requirements shall comply with the provisions of Article 336 and shall be of the multiconductor type.

*Exception: Single-conductor cables shall be permitted as the nonheating leads for heating cables as provided in Section 424-43 and in solar photovoltaic systems in accordance with Section 690-31.*

Type UF cable supported by cable trays shall be of the multiconductor type.

(FPN): See Section 310-10 for temperature limitation of conductors.

(b) **Uses Not Permitted.** Type UF cable shall not be used: (1) as service-entrance cables; (2) in commercial garages; (3) in theaters; (4) in motion picture studios; (5) in storage battery rooms; (6) in hoistways; (7) in any hazardous (classified) location; (8) embedded in poured cement, concrete, or aggregate, except where embedded in plaster as nonheating leads as provided in Article 424; (9) where exposed to direct rays of the sun, unless identified as sunlight-resistant.

*Exception: See Section 501-4(b), Exception.*

**339-4. Overcurrent Protection.** Overcurrent protection shall be provided in accordance with provisions of Section 240-3.



**339-5: Ampacity.** The ampacity of Type UF cable shall be that of 60°C (140°F) conductors in accordance with Section 310-15.

## ARTICLE 340.— POWER AND CONTROL TRAY CABLE

### Type TC

**340-1. Definition.** Type TC power and control tray cable is a factory assembly of two or more insulated conductors, with or without associated bare or covered grounding conductors under a nonmetallic sheath, approved for installation in cable trays, in raceways, or where supported by a messenger wire.

**340-2. Other Articles.** In addition to the provisions of this article, installations of Type TC tray cable shall comply with other applicable articles of this Code, especially Articles 300 and 318.

**340-3. Construction.** The insulated conductors of Type TC tray cable shall be in sizes 18 AWG through 1000 MCM copper and sizes 12 AWG through 1000 MCM aluminum or copper-clad aluminum. Insulated conductors of size 14 AWG and larger copper and size 12 AWG and larger aluminum or copper-clad aluminum shall be one of the types listed in Table 310-13 or 310-62, which is suitable for branch circuit and feeder circuits or one which is identified for such use. Insulated conductors of size No. 18 and No. 16 AWG copper shall be in accordance with Section 725-16. The outer sheath shall be a flame-retardant, nonmetallic material. A metallic sheath shall not be permitted either under or over the nonmetallic sheath. Where installed in wet locations, Type TC cable shall be resistant to moisture and corrosive agents.

**340-4. Use Permitted.** Type TC tray cable shall be permitted to be used: (1) for power, lighting, control, signal, and communication circuits; (2) in cable trays, or in raceways, or where supported in outdoor locations by a messenger wire; (3) in cable trays in hazardous (classified) locations as permitted in Articles 318 and 501 in industrial establishments where the conditions of maintenance and supervision assure that only qualified persons will service the installation; (4) for Class 1 circuits as permitted in Article 725. (FPN): See Section 310-10 for temperature limitation of conductors.

**340-5. Uses Not Permitted.** Type TC tray cable shall not be: (1) installed where they will be exposed to physical damage; (2) installed as open cable on brackets or cleats; (3) used where exposed to direct rays of the sun, unless identified as sunlight-resistant; (4) direct buried, unless identified for such use.

**340-6. Marking.** The cable shall be marked in accordance with Section 310-11.

**340-7. Ampacity.** The ampacities of the conductors of Type TC tray cable shall be determined from Section 400-5 for conductors smaller than No. 14, and Section 318-11.

**ARTICLE 342 — NONMETALLIC EXTENSIONS**

**342-1. Definition.** Nonmetallic extensions are an assembly of two insulated conductors within a nonmetallic jacket or an extruded thermoplastic covering. The classification includes both surface extensions, intended for mounting directly on the surface of walls or ceilings, and aerial cable, containing a supporting messenger cable as an integral part of the cable assembly.

**342-2. Other Articles.** In addition to the provisions of this article, nonmetallic extensions shall be installed in accordance with the applicable provisions of this Code.

**342-3. Uses Permitted.** Nonmetallic extensions shall be permitted only where all of the following conditions are met:

(a) **From an Existing Outlet.** The extension is from an existing outlet on a 15- or 20-ampere branch circuit in conformity with the requirements of Article 210.

(b) **Exposed and in a Dry Location.** The extension is run exposed and in a dry location.

(c) **Nonmetallic Surface Extensions.** For nonmetallic surface extensions, the building is occupied for residential or office purposes, and does not exceed the height limitations specified in Section 336-4(a).

(c1) **[Alternate to (c)].** For aerial cable, the building is occupied for industrial purposes, and the nature of the occupancy requires a highly flexible means for connecting equipment.

(FPN): See Section 310-10 for temperature limitation of conductors.

**342-4. Uses Not Permitted.** Nonmetallic extensions shall not be used:

(a) **Aerial Cable.** As aerial cable to substitute for one of the general wiring methods specified by this Code.

(b) **Unfinished Areas.** In unfinished basements, attics, or roof spaces.

(c) **Voltage Between Conductors.** Where the voltage between conductors exceeds 150 volts for nonmetallic surface extension and 300 volts for aerial cable.

(d) **Corrosive Vapors.** Where subject to corrosive vapors.

(e) **Through a Floor or Partition.** Where run through a floor or partition, or outside the room in which it originates.

**342-5. Splices and Taps.** Extensions shall consist of a continuous unbroken length of the assembly, without splices, and without exposed conductors between fittings. Taps shall be permitted where approved fittings completely covering the tap connections are used. Aerial cable and its tap connectors shall be provided with an approved means for polarization. Receptacle-type tap connectors shall be of the locking-type.

**342-6. Fittings.** Each run shall terminate in a fitting that covers the end of the assembly. All fittings and devices shall be of a type identified for the use.

**342-7. Installation.** Nonmetallic extensions shall be installed as specified in (a) and (b) below.

**(a) Nonmetallic Surface Extensions.**

(1) One or more extensions shall be permitted to be run in any direction from an existing outlet, but not on the floor or within 2 inches (50.8 mm) from the floor.

(2) Nonmetallic surface extensions shall be secured in place by approved means at intervals not exceeding 8 inches (203 mm).

*Exception: Where connection to the supplying outlet is made by means of an attachment plug, the first fastening shall be permitted 12 inches (305 mm) or less from the plug.*

There shall be at least one fastening between each two adjacent outlets supplied. An extension shall be attached only to woodwork or plaster finish, and shall not be in contact with any metal work or other conductive material other than with metal plates on receptacles.

(3) A bend that reduces the normal spacing between the conductors shall be covered with a cap to protect the assembly from physical damage.

**(b) Aerial Cable.**

(1) Aerial cable shall be supported by its messenger cable, securely attached at each end with approved clamps and turnbuckles. Intermediate supports shall be provided at not more than 20-foot (6.1-m) intervals. Cable tension shall be adjusted to eliminate excessive sag. The cable shall have a clearance of not less than 2 inches (50.8 mm) from steel structural members or other conductive material.

(2) Aerial cable shall have a clearance of not less than 10 feet (3.05 m) above floor areas accessible to pedestrian traffic, and not less than 14 feet (4.27 m) above floor areas accessible to vehicular traffic.

(3) Cable suspended over work benches, not accessible to pedestrian traffic, shall have a clearance of not less than 8 feet (2.44 m) above the floor.

(4) Aerial cables shall be permitted as a means to support lighting fixtures when the total load on the supporting messenger cable does not exceed that for which the assembly is intended.

(5) The supporting messenger cable, when installed in conformity with the applicable provisions of Article 250 and when properly identified as an equipment grounding conductor, shall be permitted to ground equipment. The messenger cable shall not be used as a branch-circuit conductor.

**342-8. Marking.** Nonmetallic extensions shall be marked in accordance with Section 110-21.

**ARTICLE 344 — UNDERPLASTER EXTENSIONS**

**344-1. Use.** An underplaster extension installed as permitted by this article shall be permitted only for extending an existing branch circuit in a building of fire-resistive construction.

**344-2. Materials.** Such extension shall be run in rigid metal conduit, flexible metal conduit, Type AC cable, intermediate metal conduit, rigid nonmetallic conduit, electrical metallic tubing, Type MC cable, electrical nonmetallic tubing, Type MI cable, or metal raceways.

Standard sizes of cables and raceways shall be used.

*Exception: For a single conductor only, conduit or tubing having not less than 5/16 inch inside diameter, single-conductor Type AC cable, or single-conductor Type MI cable shall be permitted.*

**344-3. Boxes and Fittings.** Boxes and fittings shall comply with the applicable provisions of Article 370.

**344-4. Installation.** An underplaster extension shall be laid on the face of masonry or other material and buried in the plaster finish of ceilings or walls. The methods of installation of the raceway or cable for such extension shall be as specified elsewhere in this Code for the particular type of material used.

**344-5. Extension to Another Floor.** No such extension shall extend beyond the floor on which it originates unless installed in a standard size of rigid metal conduit, intermediate metal conduit, electrical metallic tubing, Type AC cable, or Type MI cable.

## ARTICLE 345 — INTERMEDIATE METAL CONDUIT

### A. General

**345-1. Definition.** Intermediate metal conduit is a metal raceway of circular cross section with integral or associated couplings, connectors and fittings approved for the installation of electrical conductors.

**345-2. Other Articles.** Installations for intermediate metal conduit shall comply with the provisions of the applicable sections of Article 300.

**345-3. Uses Permitted.**

(a) **All Atmospheric Conditions and Occupancies.** Use of intermediate metal conduit shall be permitted under all atmospheric conditions and occupancies. Where practicable, dissimilar metals in contact anywhere in the system shall be avoided to eliminate the possibility of galvanic action. Intermediate metal conduit shall be permitted as an equipment grounding conductor.

(FPN): See Section 250-91(b) for types of equipment grounding conductors.

*Exception: Aluminum fittings and enclosures shall be permitted to be used with steel intermediate metal conduit.*

(b) **Corrosion Protection.** Intermediate metal conduit, elbows, couplings, and fittings shall be permitted to be installed in concrete, in direct contact with the earth, or in areas subject to severe corrosive influences when protected by corrosion protection and judged suitable for the condition.

(FPN): See Section 300-6 for protection against corrosion.

(c) **Cinder Fill.** Intermediate metal conduit shall be permitted to be installed in or under cinder fill where subject to permanent moisture when protected on all sides by a layer of noncinder concrete not less than 2 inches (50.8 mm) thick; when the conduit is not less than 18 inches (457 mm) under

the fill; or when protected by corrosion protection and judged suitable for the condition.

(FPN): See Section 300-6 for protection against corrosion.

## B. Installation

**345-5. Wet Locations.** All supports, bolts, straps, screws, etc., shall be of corrosion-resistant materials or protected against corrosion by corrosion-resistant materials.

(FPN): See Section 300-6 for protection against corrosion.

### 345-6. Size.

(a) **Minimum.** Conduit smaller than ½-inch electrical trade size shall not be used.

(b) **Maximum.** Conduit larger than 4-inch electrical trade size shall not be used.

**345-7. Number of Conductors in Conduit.** The number of conductors in a single conduit shall not exceed that permitted by the percentage fill specified in Table 1, Chapter 9, using the conduit dimensions of Table 4, Chapter 9.

**345-8. Reaming and Threading.** All cut ends of conduits shall be reamed or otherwise finished to remove rough edges. Where conduit is threaded in the field, a standard cutting die with a ¾-inch (19-mm) taper per foot (305 mm) shall be used.

(FPN): See Standards for Pipe Threads, General Purpose (Inch) ANSI/ASME B.1.20.1-1983.

### 345-9. Couplings and Connectors.

(a) **Threadless.** Threadless couplings and connectors used with conduit shall be made tight. Where buried in masonry or concrete, they shall be the concretetight type. Where installed in wet locations, they shall be the raintight type.

(b) **Running Threads.** Running threads shall not be used on conduit for connection at couplings.

**345-10. Bends — How Made.** Bends of intermediate metal conduit shall be so made that the conduit will not be damaged, and that the internal diameter of the conduit will not be effectively reduced. The radius of the curve of the inner edge of any field bend shall not be less than indicated in Table 346-10.

*Exception: For field bends for conductors without lead sheath and made with a single operation (one shot) bending machine designed for the purpose, the minimum radius shall not be less than that indicated in Table 346-10 Exception.*

**345-11. Bends — Number in One Run.** A run of conduit between outlet and outlet, between fitting and fitting, or between outlet and fitting, shall not contain more than the equivalent of four quarter bends (360 degrees, total), including those bends located immediately at the outlet or fitting.

**345-12. Supports.** Intermediate metal conduit shall be installed as a complete system as provided in Article 300 and shall be securely fastened in place. Conduit shall be firmly fastened within 3 feet (914 mm) of each outlet

box, junction box, cabinet, or fitting. Conduit shall be supported at least every 10 feet (3.05 m).

*Exception No. 1: If made up with threaded couplings, it shall be permissible to support straight runs of intermediate metal conduit in accordance with Table 346-12, provided such supports prevent transmission of stresses to termination where conduit is deflected between supports.*

*Exception No. 2: The distance between supports shall be permitted to be increased to 20 feet (6.1 m) for exposed vertical risers from industrial machinery, provided that the conduit is made up with threaded couplings firmly supported at the top and bottom of the riser, and no other means of intermediate support is readily available.*

**345-13. Boxes and Fittings.** See Article 370.

**345-14. Splices and Taps.** Splices and taps shall be made only in junction boxes, outlet boxes or conduit bodies. See Article 370.

**345-15. Bushings.** Where a conduit enters a box, fitting, or other enclosure, a bushing shall be provided to protect the wire from abrasion unless the design of the box, fitting, or enclosure is such as to afford equivalent protection.

(FPN): See Section 373-6(c) for the protection of conductors No. 4 AWG and larger at bushings.

### C. Construction Specifications

**345-16. General.** Intermediate metal conduit shall comply with (a) through (c) below.

(a) **Standard Lengths.** Intermediate metal conduit as shipped shall be in standard lengths of 10 feet (3.05 m) including coupling, one coupling to be furnished with each length. For specific applications or use, it shall be permissible to ship lengths shorter or longer than 10 feet (3.05 m), with or without couplings.

(b) **Corrosion-Resistant Material.** Nonferrous conduit of corrosion-resistant material shall have suitable markings.

(c) **Marking.** Each length shall be clearly and durably identified at 2½-foot (762-mm) intervals with the letters IMC. Each length shall be marked as required in the first sentence of Section 110-21.

## ARTICLE 346 — RIGID METAL CONDUIT

**346-1. Use.** The use of rigid metal conduit shall be permitted under all atmospheric conditions and occupancies subject to the following:

(a) **Protected by Enamel.** Ferrous raceways and fittings protected from corrosion solely by enamel shall be permitted only indoors and in occupancies not subject to severe corrosive influences.

(b) **Dissimilar Metals.** Where practicable, dissimilar metals in contact anywhere in the system shall be avoided to eliminate the possibility of galvanic action.

*Exception: Aluminum fittings and enclosures shall be permitted to be used with steel rigid metal conduit, and also, steel fittings and enclosures shall be permitted to be used with aluminum rigid metal conduit.*

**(c) Corrosion Protection.** Ferrous or nonferrous metal conduit, elbows, couplings, and fittings shall be permitted to be installed in concrete, in direct contact with the earth, or in areas subject to severe corrosive influences where protected by corrosion protection and judged suitable for the condition.

(FPN): See Section 300-6 for protection against corrosion.

**346-2. Other Articles.** Installations of rigid metal conduit shall comply with the applicable provisions of Article 300.

### A. Installation

**346-3. Cinder Fill.** Conduit shall not be used in or under cinder fill where subject to permanent moisture.

*Exception No. 1: Where of corrosion-resistant material suitable for the purpose.*

*Exception No. 2: Where protected on all sides by a layer of noncinder concrete at least 2 inches (50.8 mm) thick.*

*Exception No. 3: Where the conduit is at least 18 inches (457 mm) under the fill.*

**346-4. Wet Locations.** All supports, bolts, straps, screws, etc., shall be of corrosion-resistant materials or protected against corrosion by corrosion-resistant materials.

(FPN): See Section 300-6 for protection against corrosion.

**346-5. Minimum Size.** Conduit smaller than ½-inch electrical trade size shall not be used.

*Exception No. 1: For underplaster extensions as permitted in Section 344-2.*

*Exception No. 2: For enclosing the leads of motors as permitted in Section 430-145(b).*

**346-6. Number of Conductors in Conduit.** The number of conductors permitted in a single conduit shall not exceed the percentage fill specified in Table 1, Chapter 9.

(FPN): For conductor cross-sectional area see Tables 5, 5A, 6, 7, 8 and the applicable Notes to Tables at the beginning of Chapter 9.

**346-7. Reaming and Threading.**

**(a) Reamed.** All cut ends of conduits shall be reamed or otherwise finished to remove rough edges.

**(b) Threaded.** Where conduit is threaded in the field, a standard conduit cutting die with a ¼-inch (19-mm) taper per foot (305 mm) shall be used.

(FPN): See Standards for Pipe Threads, General Purpose (Inch) ANSI/ASME, B.1.20.1-1983.

**346-8. Bushings.** Where a conduit enters a box, fitting, or other enclosure, a bushing shall be provided to protect the wire from abrasion unless the box, fitting, or enclosure design provides equivalent protection.

(FPN): See Section 373-6(c) for the protection of conductors at bushings.

**346-9. Couplings and Connectors.**

(a) **Threadless.** Threadless couplings and connectors used with conduit shall be made tight. Where buried in masonry or concrete, they shall be of the concretetight type. Where installed in wet locations, they shall be of the raintight type.

(b) **Running Threads.** Running threads shall not be used on conduit for connection at couplings.

**346-10. Bends — How Made.** Bends of rigid metal conduit shall be so made that the conduit will not be damaged, and that the internal diameter of the conduit will not be effectively reduced. The radius of the curve of the inner edge of any field bend shall not be less than shown in Table 346-10.

*Exception: For field bends for conductors without lead sheath and made with a single operation (one shot) bending machine designed for the purpose, the minimum radius shall not be less than indicated in Table 346-10 Exception.*

**346-11. Bends — Number in One Run.** A run of conduit between outlet and outlet, fitting and fitting, or outlet and fitting shall not contain more than the equivalent of four quarter bends (360 degrees, total), including those bends located immediately at the outlet or fitting.

**Table 346-10**  
**Radius of Conduit Bends (Inches)**

Size of Conduit (In.)	Conductors Without Lead Sheath (In.)	Conductors With Lead Sheath (In.)
1/2	4	6
3/4	5	8
1	6	11
1 1/4	8	14
1 1/2	10	16
2	12	21
2 1/2	15	25
3	18	31
3 1/2	21	36
4	24	40
5	30	50
6	36	61

For SI units: (Radius) one inch = 25.4 millimeters.



**Table 346-10 Exception.  
Radius of Conduit Bends (Inches)**

Size of Conduit (In.)	Radius to Center of Conduit (In.)
1/2	4
3/4	4 1/2
1	5 3/4
1 1/4	7 1/4
1 1/2	8 1/4
2	9 1/2
2 1/2	10 1/2
3	13
3 1/2	15
4	16
5	24
6	30

For SI units: (Radius) one inch = 25.4 millimeters.

**346-12. Supports.** Rigid metal conduit shall be installed as a complete system as provided in Article 300 and shall be securely fastened in place. Conduit shall be firmly fastened within 3 feet (914 mm) of each outlet box, junction box, cabinet, or fitting. Conduit shall be supported at least every 10 feet (3.05 m).

*Exception No. 1: If made up with threaded couplings, it shall be permissible to support straight runs of rigid metal conduit in accordance with Table 346-12, provided such supports prevent transmission of stresses to termination where conduit is deflected between supports.*

*Exception No. 2: The distance between supports shall be permitted to be increased to 20 feet (6.1 m) for exposed vertical risers from industrial machinery, provided that the conduit is made up with threaded couplings, is firmly supported at the top and bottom of the riser, and no other means of intermediate support is readily available.*

**Table 346-12. Supports for Rigid Metal Conduit.**

Conduit Size (Inches)	Maximum Distance Between Rigid Metal Conduit Supports (Feet)
1/2-3/4	10
1	12
1 1/4-1 1/2	14
2-2 1/2	16
3 and larger	20

For SI units: (Supports) one foot = 0.3048 meter.

**346-13. Boxes and Fittings.** Boxes and fittings shall comply with the applicable provisions of Article 370.

**346-14. Splices and Taps.** Splices and taps shall be made only in junction boxes, outlet boxes or conduit bodies. See Article 370.

### B. Construction Specifications

**346-15. General.** Rigid metal conduit shall comply with (a) through (c) below.

(a) **Standard Lengths.** Rigid metal conduit as shipped shall be in standard lengths of 10 feet (3.05 m) including coupling, one coupling to be furnished with each length. Each length shall be reamed and threaded on each end. For specific applications or uses, it shall be permissible to ship standard lengths or lengths shorter or longer than 10 feet (3.05 m) with or without couplings and with or without threads.

(b) **Corrosion-Resistant Material.** Nonferrous conduit of corrosion-resistant material shall have suitable markings.

(c) **Durably Identified.** Each length shall be clearly and durably identified in every 10 feet (3.05 m) as required in the first sentence of Section 110-21.

## ARTICLE 347 — RIGID NONMETALLIC CONDUIT

**347-1. Description.** This article shall apply to a type of conduit and fittings of suitable nonmetallic material that is resistant to moisture and chemical atmospheres. For use aboveground, it shall also be flame-retardant, resistant to impact and crushing, resistant to distortion from heat under conditions likely to be encountered in service, and resistant to low temperature and sunlight effects. For use underground, the material shall be acceptably resistant to moisture and corrosive agents and shall be of sufficient strength to withstand abuse, such as by impact and crushing, in handling and during installation. Where intended for direct burial, without encasement in concrete, the material shall also be capable of withstanding continued loading that is likely to be encountered after installation.

(FPN): Materials that have been recognized as having suitable physical characteristics when properly formed and treated include fiber, asbestos cement, soapstone, rigid polyvinyl chloride, fiberglass epoxy, and high-density polyethylene for underground use, and rigid polyvinyl chloride for use aboveground.

**347-2. Uses Permitted.** The use of rigid nonmetallic conduit and fittings shall be permitted under the following conditions:

(FPN): Extreme cold may cause some nonmetallic conduits to become brittle and therefore more susceptible to damage from physical contact:

(a) **Concealed.** In walls, floors, and ceilings.

(b) **Corrosive Influences.** In locations subject to severe corrosive influences as covered in Section 300-6 and where subject to chemicals for which the materials are specifically approved.

(c) **Cinders.** In cinder fill.

(d) **Wet Locations.** In portions of dairies, laundries, canneries, or other wet locations and in locations where walls are frequently washed, the entire conduit system including boxes and fittings used therewith shall be so installed and equipped as to prevent water from entering the conduit. All

supports, bolts, straps, screws, etc., shall be of corrosion-resistant materials or be protected against corrosion by approved corrosion-resistant materials.

(e) **Dry and Damp Locations.** In dry and damp locations not prohibited by Section 347-3.

(f) **Exposed.** For exposed work where not subject to physical damage if identified for such use.

(g) **Underground Installations.** For underground installations, see Sections 300-5 and 710-3(b).

**347-3. Uses Not Permitted.** Rigid nonmetallic conduit shall not be used:

(a) **Hazardous (Classified) Locations.** In hazardous (classified) locations, except as covered in Sections 514-8 and 515-5; and Class I, Division 2 locations as permitted in the Exception to Section 501-4(b).

(b) **Support of Fixtures.** For the support of fixtures or other equipment.

(c) **Physical Damage.** Where subject to physical damage unless identified for such use.

(d) **Ambient Temperatures.** Where subject to ambient temperatures exceeding those for which the conduit is approved.

(e) **Insulation Temperature Limitations.** For conductors whose insulation temperature limitations would exceed those for which the conduit is approved.

**347-4. Other Articles.** Installation of rigid nonmetallic conduit shall comply with the applicable provisions of Article 300. Where equipment grounding is required by Article 250, a separate equipment grounding conductor shall be installed in the conduit.

### A. Installations

**347-5. Trimming.** All cut ends shall be trimmed inside and outside to remove rough edges.

**347-6. Joints.** All joints between lengths of conduit, and between conduit and couplings, fittings, and boxes, shall be made by an approved method.

**347-8. Supports.** Rigid nonmetallic conduit shall be secured as required by Table 347-8. In addition, conduit shall be securely fastened within 3 feet (914 mm) of each box, cabinet, or other conduit termination.

**Table 347-8. Support of Rigid Nonmetallic Conduit**

Conduit Size (Inches)	Maximum Spacing Between Supports (Feet)
1/2-1	3
1 1/4-2	5
2 1/2-3	6
3 1/2-5	7
6	8

For SI units: (Supports) one foot = 0.3048 meter.

**347-9. Expansion Joints.** Expansion joints for rigid nonmetallic conduit shall be provided to compensate for thermal expansion and contraction.

**347-10. Minimum Size.** No conduit smaller than ½-inch electrical trade size shall be used.

**347-11. Number of Conductors.** The number of conductors permitted in a single conduit shall not exceed the percentage fill specified in Table 1, Chapter 9.

(FPN): For conductor cross-sectional area see Tables 5, 5A, 6, 7, 8 and the applicable Notes to Tables at the beginning of Chapter 9.

**347-12. Bushings.** Where a conduit enters a box or other fitting, a bushing or adapter shall be provided to protect the wire from abrasion unless the design of the box or fitting is such as to provide equivalent protection.

(FPN): See Section 373-6(c) for the protection of conductors No. 4 AWG and larger at bushings.

**347-13. Bends — How Made.** Bends of rigid nonmetallic conduit shall be so made that the conduit will not be damaged and that the internal diameter of the conduit will not be effectively reduced. Field bends shall be made only with bending equipment identified for the purpose, and the radius of the curve of the inner edge of such bends shall not be less than shown in Table 346-10.

**347-14. Bends — Number in One Run.** A run of conduit between outlet and outlet, fitting and fitting, or outlet and fitting shall not contain more than the equivalent of four quarter bends (360 degrees, total), including those bends located immediately at the outlet or fitting.

**347-15. Boxes and Fittings.** Boxes and fittings shall comply with the applicable provisions of Article 370.

**347-16. Splices and Taps.** Splices and taps shall be made only in junction boxes, outlet boxes or conduit bodies. See Article 370.

## B. Construction Specifications

**347-17. General.** Rigid nonmetallic conduit shall comply with the following:

**Marking.** Each length of nonmetallic conduit shall be clearly and durably marked at least every 10 feet (3.05 m) as required in the first sentence of Section 110-21. The type of material shall also be included in the marking unless it is visually identifiable. For conduit recognized for use aboveground these markings shall be permanent. For conduit limited to underground use only, these markings shall be sufficiently durable to remain legible until the material is installed.

## ARTICLE 348 — ELECTRICAL METALLIC TUBING

**348-1. Use.** The use of electrical metallic tubing shall be permitted for both exposed and concealed work. Electrical metallic tubing shall not be

used: (1) where, during installation or afterward, it will be subject to severe physical damage; (2) where protected from corrosion solely by enamel; (3) in cinder concrete or cinder fill where subject to permanent moisture, unless protected on all sides by a layer of noncinder concrete at least 2 inches (50.8 mm) thick or unless the tubing is at least 18 inches (457 mm) under the fill. Where practicable, dissimilar metals in contact anywhere in the system shall be avoided to eliminate the possibility of galvanic action.

*Exception: Aluminum fittings and enclosures shall be permitted to be used with steel electrical metallic tubing.*

Ferrous or nonferrous electrical metallic tubing, elbows, couplings, and fittings shall be permitted to be installed in concrete, in direct contact with the earth, or in areas subject to severe corrosive influences when protected by corrosion protection and judged suitable for the condition.

(FPN): See Section 300-6 for protection against corrosion.

**348-2. Other Articles.** Installations of electrical metallic tubing shall comply with the applicable provisions of Article 300.

### A. Installation

**348-4. Wet Locations.** All supports, bolts, straps, screws, etc., shall be of corrosion-resistant materials or protected against corrosion by corrosion-resistant materials.

(FPN): See Section 300-6 for protection against corrosion.

**348-5. Size.**

(a) **Minimum:** Tubing smaller than ½-inch electrical trade size shall not be used.

*Exception No. 1: For underplaster extensions as permitted in Section 344-2.*

*Exception No. 2: For enclosing the leads of motors as permitted in Section 430-145(b).*

(b) **Maximum.** The maximum size of tubing shall be the 4-inch electrical trade size.

**348-6. Number of Conductors in Tubing.** The number of conductors permitted in a single tubing shall not exceed the percentage fill specified in Table 1, Chapter 9.

(FPN): For conductor cross-sectional area see Tables 5, 5A, 6, 7, 8 and the applicable Notes to Tables at the beginning of Chapter 9.

**348-7. Threads.** Electrical metallic tubing shall not be threaded. Where integral couplings are utilized, such couplings shall be permitted to be factory threaded.

**348-8. Couplings and Connectors.** Couplings and connectors used with tubing shall be made up tight. Where buried in masonry or concrete, they shall be concretetight type. Where installed in wet locations, they shall be of the raintight type.

**348-9. Bends — How Made.** Bends in the tubing shall be so made that the tubing will not be damaged and that the internal diameter of the tubing will

not be effectively reduced. The radius of the curve of the inner edge of any field bend shall not be less than shown in Table 346-10.

*Exception: For field bends made with a bending machine designed for the purpose, the minimum radius shall not be less than indicated in Table 346-10.*  
*Exception.*

**348-10. Bends — Number in One Run.** A run of electrical metallic tubing between outlet and outlet, fitting and fitting, or outlet and fitting shall not contain more than the equivalent of four-quarter bends (360 degrees, total), including those bends located immediately at the outlet or fitting.

**348-11. Reaming.** All cut ends of electrical metallic tubing shall be reamed or otherwise finished to remove rough edges.

**348-12. Supports.** Electrical metallic tubing shall be installed as a complete system as provided in Article 300 and shall be securely fastened in place at least every 10 feet (3.05 m) and within 3 feet (914 mm) of each outlet box, junction box, cabinet, or fitting.

**348-13. Boxes and Fittings.** Boxes and fittings shall comply with the applicable provisions of Article 370.

**348-14. Splices and Taps.** Splices and taps shall be made only in junction boxes, outlet boxes or conduit bodies. See Article 370.

### B. Construction Specifications

**348-15. General.** Electrical metallic tubing shall comply with (a) through (c) below.

(a) **Cross Section.** The tubing, and elbows and bends for use with the tubing, shall have a circular cross section.

(b) **Finish.** Tubing shall have such a finish or treatment of outer surfaces as will provide an approved durable means of readily distinguishing it, after installation, from rigid metal conduit.

(c) **Connectors.** Where the tubing is coupled together by threads, the connector shall be so designed as to prevent bending of the tubing at any part of the thread.

## ARTICLE 349 — FLEXIBLE METALLIC TUBING

### A. General

**349-1. Scope.** The provisions of this article apply to a raceway for electric conductors which is circular in cross section, flexible, metallic, and liquidtight without a nonmetallic jacket.

**349-2. Other Articles.** Installations of flexible metallic tubing shall comply with the provisions of the applicable sections of Article 300.

**349-3. Uses Permitted.** Flexible metallic tubing shall be permitted to be used: (1) in dry locations; (2) in accessible locations when protected from

physical damage or concealed such as above suspended ceilings; (3) for 1000 volts maximum; and (4) in branch circuits.

**349-4. Uses Not Permitted.** Flexible metallic tubing shall not be used: (1) in hoistways; (2) in storage battery rooms; (3) in hazardous (classified) locations unless otherwise permitted under other articles in this Code; (4) underground for direct earth burial, or embedded in poured concrete or aggregate; (5) where subject to physical damage; and (6) in lengths over 6 feet (1.83 m).

## B. Construction and Installation

### 349-10. Size.

(a) **Minimum.** Flexible metallic tubing smaller than 1/2-inch electrical trade size shall not be used.

*Exception No. 1: 3/8-inch trade size shall be permitted to be installed in accordance with Section 300-22(b) and (c).*

*Exception No. 2: 3/8-inch trade size shall be permitted in lengths not in excess of 6 feet (1.83 m) as part of an approved assembly or for lighting fixtures. See Section 410-67(c).*

(b) **Maximum.** The maximum size of flexible metallic tubing shall be the 3/4-inch trade size.

### 349-12. Number of Conductors.

(a) **1/2-Inch and 3/4-Inch Flexible Metallic Tubing.** The number of conductors permitted in 1/2-inch and 3/4-inch trade sizes of flexible metallic tubing shall not exceed the percentage of fill specified in Table 1, Chapter 9.

(b) **3/8-Inch Flexible Metallic Tubing.** The number of conductors permitted in 3/8-inch trade size flexible metallic tubing shall not exceed that permitted in Table 350-3.

(FPN): For conductor cross-sectional area see Tables 5, 5A, 6, 7, 8 and the applicable Notes to Tables at the beginning of Chapter 9.

**349-16. Grounding.** See Section 250-91(b), Exception No. 1.

**349-18. Fittings.** Flexible metallic tubing shall be used only with approved terminal fittings. Fittings shall effectively close any openings in the connection.

(FPN): See Sections 300-22(b) and (c) for use in ducts, plenums, and other spaces used for environmental air.

### 349-20. Bends.

(a) **Infrequent Flexing Use.** Where the flexible metallic tubing shall be infrequently flexed in service after installation, the radii of bends measured to the inside of the bend shall not be less than specified in Table 349-20(a).

(b) **Fixed Bends.** Where the flexible metallic tubing is bent for installation purposes and is not flexed or bent as required by use after installation, the radii of bends measured to the inside of the bend shall not be less than specified in Table 349-20(b).

**Table 349-20(a). Minimum Radii for Flexing Use**

Trade Size	Minimum Radii
3/8 inch	10 inches
1/2 inch	12½ inches
3/4 inch	17½ inches

For SI units: (Radii) one inch = 25.4 millimeters.

**Table 349-20(b). Minimum Radii for Fixed Bends**

Trade Size	Minimum Radii
3/8 inch	3½ inches
1/2 inch	4 inches
3/4 inch	5 inches

For SI units: (Radii) one inch = 25.4 millimeters.

## ARTICLE 350 — FLEXIBLE METAL CONDUIT

**350-1. Other Articles.** Installations of flexible metal conduit shall comply with the applicable provisions of Articles 300, 333, and 346.

**350-2. Use.** Flexible metal conduit shall not be used: (1) in wet locations unless conductors are of lead-covered type or of other types approved for the specific conditions and the installation is such that water is not likely to enter other raceways or enclosures to which the conduit is connected; (2) in hoistways, other than provided in Section 620-21; (3) in storage-battery rooms; (4) in any hazardous (classified) location other than permitted in Section 501-4(b); (5) where rubber-covered conductors are exposed to oil, gasoline, or other materials having a deteriorating effect on rubber; nor (6) underground or embedded in poured concrete or aggregate.

**350-3. Minimum Size.** Flexible metal conduit less than 1/2-inch electrical trade size shall not be used.

*Exception No. 1: For underplaster extensions as permitted in Section 344-2.*

*Exception No. 2: For enclosing the leads of motors as permitted in Section 430-145(b).*

*Exception No. 3: Flexible metal conduit of 3/8-inch nominal trade size shall be permitted in lengths not in excess of 6 feet (1.83-m) as a part of an approved assembly, or for tap connections to lighting fixtures as required in Section 410-67(c), or for lighting fixtures.*

*Exception No. 4: Flexible metal conduit of 3/8-inch nominal trade size shall be permitted for manufactured wiring systems as permitted in Section 604-6(a).*

*Exception No. 5: As permitted in Section 620-21, Exception No. 5.*



**Table 350-3. Maximum Number of Insulated Conductors in 3/8-Inch Flexible Metal Conduit.\***

Col. A = With fitting inside conduit.  
Col. B = With fitting outside conduit.

Size AWG	Types RFH-2, SF-2		Types TF, T, XHHW, AF, TW, RUH, RUW		Types TFN, THHN, THWN		Types FEP, FEPB, PF, PGF	
	A	B	A	B	A	B	A	B
18	..	3	3	7	4	8	5	8
16	..	2	2	4	3	7	4	8
14	..	..	..	4	3	7	3	7
12	..	..	..	3	..	4	..	4
10	..	..	..	..	..	2	..	3

\* In addition, one uninsulated equipment grounding conductor of the same size shall be permitted.

**350-4. Supports.** Flexible metal conduit shall be secured by an approved means at intervals not exceeding 4½ feet (1.37 m) and within 12 inches (305 mm) on each side of every outlet box, junction box, cabinet, or fitting.

*Exception No. 1: Where flexible metal conduit is fished.*

*Exception No. 2: Lengths not exceeding 3 feet (914 mm) at terminals where flexibility is necessary.*

*Exception No. 3: Lengths not exceeding 6 feet (1.83 m) from a fixture terminal connection for tap connections to lighting fixtures as required in Section 410-67(c).*

**350-5. Grounding.** Flexible metal conduit shall be permitted as a grounding means as covered in Section 250-91(b). Where an equipment bonding jumper is required around flexible metal conduit, it shall be installed in accordance with Section 250-79.

*Exception No. 1: Flexible metal conduit shall be permitted as a grounding means if the total length in any ground return path is 6 feet (1.83 m) or less, the conduit is terminated in fittings approved for grounding, and the circuit conductors contained therein are protected by overcurrent devices rated at 20 amperes or less.*

*Exception No. 2: Where used to connect equipment where flexibility is required, a grounding conductor shall be installed.*

**350-6. Bends.** A run of conduit between outlet and outlet, fitting and fitting, or outlet and fitting shall not contain more than the equivalent of four quarter bends (360 degrees, total); including those bends located immediately at the outlet or fitting.

Angle connectors shall not be used for concealed raceway installations.

## ARTICLE 351 — LIQUIDTIGHT FLEXIBLE METAL CONDUIT AND LIQUIDTIGHT FLEXIBLE NONMETALLIC CONDUIT

**351-1. Scope.** This article covers liquidtight flexible metal conduit and liquidtight flexible nonmetallic conduit.

### A. Liquidtight Flexible Metal Conduit

**351-2. Definition.** Liquidtight flexible metal conduit is a raceway of circular cross section having an outer liquidtight, nonmetallic, sunlight-resistant jacket over an inner flexible metal core with associated couplings, connectors, and fittings and approved for the installation of electric conductors.

**351-3. Other Articles.** Installations of liquidtight flexible metal conduit shall comply with the applicable provisions of Article 300 and with the specific sections of Articles 350, 501, 502, 503, and 553 referenced below.

### 351-4. Use.

**(a) Permitted.** The use of listed and marked liquidtight flexible metal conduit shall be permitted for direct burial in earth and for exposed and concealed work:

(1) Where conditions of installation, operation, or maintenance require flexibility or protection from liquids, vapors, or solids.

(2) As permitted by Sections 501-4(b), 502-4, and 503-3, and in other hazardous (classified) locations where specifically approved, and by Section 553-7(b).

**(b) Not Permitted.** Liquidtight flexible metal conduit shall not be used:

(1) Where subject to physical damage.

(2) Where any combination of ambient and/or conductor temperature will produce an operating temperature in excess of that for which the material is approved.

### 351-5. Size.

**(a) Minimum.** Liquidtight flexible metal conduit smaller than ½-inch electrical trade size shall not be used.

*Exception: ¾-inch size shall be permitted as covered in Section 350-3.*

**(b) Maximum.** The maximum size of liquidtight flexible metal conduit shall be the 4-inch trade size.

### 351-6. Number of Conductors.

**(a) Single Conduit.** The number of conductors permitted in a single conduit, ½- through 4-inch trade sizes, shall not exceed the percentage of fill specified in Table 1, Chapter 9.

**(b) ¾-Inch Liquidtight Flexible Metal Conduit.** The number of conductors permitted in ¾-inch liquidtight flexible metal conduit shall not exceed that permitted in Table 350-3.

**351-7. Fittings.** Liquidtight flexible metal conduit shall be used only with approved terminal fittings.

**351-8. Supports.** Where liquidtight flexible metal conduit is installed as a fixed raceway, it shall be secured at intervals not exceeding 4½ feet (1.37 m) and within 12 inches (305 mm) on each side of every outlet box, junction box, cabinet, or fitting.

*Exception No. 1: Where liquidtight flexible metal conduit is fished.*

*Exception No. 2: Lengths not exceeding 3 feet (914 mm) at terminals where flexibility is necessary.*

*Exception No. 3: Lengths not exceeding 6 feet (1.83 m) from a fixture terminal connection for tap conductors to lighting fixtures as required in Section 410-67(c).*

**351-9. Grounding.** Liquidtight flexible metal conduit shall be permitted as a grounding conductor where both the conduit and the fittings are approved for grounding. Where an equipment bonding jumper is required around liquidtight flexible metal conduit, it shall be installed in accordance with Section 250-79.

*Exception No. 1: Liquidtight flexible metal conduit shall be permitted as a grounding means in the 1¼-inch and smaller trade sizes if the total length of all liquidtight flexible metal conduit in any ground return path is 6 feet (1.83 m) or less, the conduit is terminated in fittings listed for grounding, and the circuit conductors contained therein are protected by overcurrent devices rated at 20 amperes or less for ¾-inch and ½-inch trade sizes and 60 amperes or less for ¾-inch through 1¼-inch trade sizes.*

*Exception No. 2: When used to connect equipment where flexibility is required, an equipment grounding conductor shall be installed.*

(FPN): See Sections 501-16(b), 502-16(b), and 503-16(b) for types of equipment grounding conductors.

**351-10. Bends.** A run of conduit between outlet and outlet, fitting and fitting, or outlet and fitting shall not contain more than the equivalent of four quarter bends (360 degrees, total); including those bends located immediately at the outlet or fitting.

Angle connectors shall not be used for concealed raceway installations.

## B. Liquidtight Flexible Nonmetallic Conduit

**351-22. Definition.** Liquidtight flexible nonmetallic conduit is a raceway of circular cross section having a smooth inner surface with integral reinforcement within the conduit wall. This conduit is flame-resistant and with fittings is approved for the installation of electrical conductors.

**351-23. Use.**

(a) **Permitted.** Liquidtight flexible nonmetallic conduit shall be permitted to be used in exposed locations:

(FPN): Extreme cold may cause some types of nonmetallic conduits to become brittle and therefore more susceptible to damage from physical contact.

(1) Where flexibility is required for installation, operation, or maintenance;

(2) Where protection of the contained conductors is required from vapors, liquids; or solids;

(3) For outdoor locations where listed and marked as suitable for the purpose.

(b) **Not Permitted.** Liquidtight flexible nonmetallic conduit shall not be used:

(1) Where subject to physical damage;

(2) Where any combination of ambient and conductor temperatures is in excess of that for which the liquidtight flexible nonmetallic conduit is approved;

(3) In lengths longer than 6 feet (1.83 m);

*Exception: Where approved for special installations.*

(4) Where voltage of the contained conductors is in excess of 600 volts, nominal.

**351-24. Size.** The sizes of liquidtight flexible nonmetallic conduit shall be electrical trade sizes  $\frac{1}{2}$  inch to 2 inch inclusive.

*Exception:  $\frac{3}{8}$ -inch size for enclosing the leads of motors as permitted in Section 430-145(b).*

**351-25. Number of Conductors.** The number of conductors permitted in a single conduit shall be in accordance with the percentage fill specified in Table 1, Chapter 9.

**351-26. Fittings.** Liquidtight flexible nonmetallic conduit shall be used only with terminal fittings identified for such use.

**351-27. Equipment Grounding.** Where an equipment grounding conductor is required for the circuits installed in liquidtight flexible nonmetallic conduit, it shall be permitted to be installed on the inside or outside of the conduit. Where installed on the outside, the length of the equipment grounding conductor shall not exceed 6 feet (1.83 m) and shall be routed with the raceway or enclosure. Fittings and boxes shall be bonded or grounded in accordance with Article 250.

## ARTICLE 352 — SURFACE METAL RACEWAYS AND SURFACE NONMETALLIC RACEWAYS

### A. Surface Metal Raceways

**352-1. Use.** The use of surface metal raceways shall be permitted in dry locations. They shall not be used: (1) where subject to severe physical damage unless otherwise approved; (2) where the voltage is 300 volts or more between conductors unless the metal has a thickness of not less than .040 inch (1.02 mm); (3) where subject to corrosive vapors; (4) in hoistways; (5) in any hazardous (classified) location except Class I, Division 2 locations as permitted in the Exception to Section 501-4(b); nor (6) concealed except as follows:

*Exception No. 1: Surface metal raceways shall be permitted for underplaster extensions where identified for such use.*

*Exception No. 2: As permitted in Section 645-2(c)(2).*

(FPN): See definition of "Exposed — (As applied to wiring methods)" in Article 100.

**352-2. Other Articles.** Surface metal raceways shall comply with the applicable provisions of Article 300.

**352-3. Size of Conductors.** No conductor larger than that for which the raceway is designed shall be installed in surface metal raceway.

**352-4. Number of Conductors in Raceways.** The number of conductors installed in any raceway shall be no greater than the number for which the raceway is designed.

The derating factors in Note 8 (a) to Tables 310-16 through 310-31 shall not apply to conductors installed in surface metal raceways when all of the following conditions are met: (1) the cross-sectional area of the raceway exceeds 4 square inches (2580 sq mm); (2) the current-carrying conductors do not exceed thirty in number; (3) the sum of the cross-sectional area of all contained conductors does not exceed 20 percent of the interior cross-sectional area of the surface metal raceway.

(FPN): For conductor cross-sectional area see Tables 5, 5A, 6, 7, 8 and the applicable Notes to Tables at the beginning of Chapter 9.

**352-5. Extension Through Walls and Floors.** It shall be permissible to extend unbroken lengths of surface metal raceways through dry walls, dry partitions, and dry floors.

(FPN): See Section 353-3 for multioutlet assemblies.

**352-6. Combination Raceways.** Where combination surface metal raceways are used both for signaling and for lighting and power circuits, the different systems shall be run in separate compartments identified by sharply contrasting colors of the interior finish, and the same relative position of compartments shall be maintained throughout the premises.

**352-7. Splices and Taps.** Splices and taps shall be permitted in surface metal raceway having a removable cover that is accessible after installation. The conductors, including splices and taps, shall not fill the raceway to more than 75 percent of its area at that point. Splices and taps in surface metal raceways without removable covers shall be made only in junction boxes. All splices and taps shall be made by approved methods.

**352-8. Construction.** Surface metal raceways shall be of such construction as will distinguish them from other raceways. Surface metal raceways and their elbows, couplings, and similar fittings shall be so designed that the sections can be electrically and mechanically coupled together without subjecting the wires to abrasion. Holes for screws or bolts inside the raceway shall be so designed that when screws or bolts are installed the heads will be flush with the metal surface.

Where covers and accessories of nonmetallic materials are used on surface metal raceways, they shall be identified for such use.

## **B. Surface Nonmetallic Raceways**

**352-21. Description.** Part B of this article shall apply to a type of surface nonmetallic raceway and fittings of suitable nonmetallic material that is

resistant to moisture and chemical atmospheres. It shall also be flame-retardant, resistant to impact and crushing, resistant to distortion from heat under conditions likely to be encountered in service, and resistant to low-temperature effects.

**352-22. Use.** The use of surface nonmetallic raceways shall be permitted in dry locations. They shall not be used: (1) where concealed; (2) where subject to severe physical damage; (3) where the voltage is 300 volts or more between conductors; (4) in hoistways; (5) in any hazardous (classified) location except Class I, Division 2 locations as permitted in the Exception to Section 501-4(b); (6) where subject to ambient temperature exceeding 50°C; nor (7) for conductors whose insulation temperature exceeds 75°C.

**352-23. Other Articles.** Surface nonmetallic raceways shall comply with the applicable provisions of Article 300.

**352-24. Size of Conductors.** No conductor larger than that for which the raceway is designed shall be installed in surface nonmetallic raceway.

**352-25. Number of Conductors in Raceways.** The number of conductors installed in any raceway shall be no greater than the number for which the raceway is designed.

**352-26. Combination Raceways.** Where combination surface nonmetallic raceways are used both for signaling and for lighting and power circuits, the different systems shall be run in separate compartments, identified by printed legend or by sharply contrasting colors of the interior finish, and the same relative position of compartments shall be maintained throughout the premises.

**352-27. General.** Surface nonmetallic raceways shall be of such construction as will distinguish them from other raceways. Surface nonmetallic raceways and their elbows, couplings, and similar fittings shall be so designed that the sections can be mechanically coupled together without subjecting the wires to abrasion. Holes for screws or bolts inside the raceway shall be so designed that when screws or bolts are installed the heads will be flush with the nonmetallic surface.

## ARTICLE 353 — MULTIOUTLET ASSEMBLY

**353-1. Other Articles.** A multioutlet assembly shall comply with applicable provisions of Article 300.

(FPN): See definition in Article 100.

**353-2. Use.** The use of multioutlet assembly shall be permitted in dry locations. It shall not be installed: (1) where concealed, except that it shall be permissible to surround the back and sides of a metal multioutlet assembly by the building finish or recess a nonmetallic multioutlet assembly in a baseboard; (2) where subject to severe physical damage; (3) where the voltage is 300 volts or more between conductors unless the assembly is of metal having a thickness of not less than .040 inch (1.02 mm); (4) where subject to corrosive vapors; (5) in hoistways; nor (6) in any hazardous (classified)

locations except Class I, Division 2 locations as permitted in the Exception to Section 501-4(b).

**353-3. Metal Multioutlet Assembly Through Dry Partitions.** It shall be permissible to extend a metal multioutlet assembly through (not run within) dry partitions, if arrangements are made for removing the cap or cover on all exposed portions and no outlet is located within the partitions.

## ARTICLE 354 — UNDERFLOOR RACEWAYS

**354-1. Other Articles.** Underfloor raceways shall comply with the applicable provisions of Article 300.

**354-2. Use.** The installation of underfloor raceways shall be permitted beneath the surface of concrete or other flooring material or in office occupancies, where laid flush with the concrete floor and covered with linoleum or equivalent floor covering. Underfloor raceways shall not be installed (1) where subject to corrosive vapors, nor (2) in any hazardous (classified) location except Class I, Division 2 locations as permitted in the Exception to Section 501-4(b). Unless made of a material judged suitable for the condition or unless corrosion protection approved for the condition is provided, ferrous or nonferrous metal underfloor raceways, junction boxes, and fittings shall not be installed in concrete, or in areas subject to severe corrosive influences.

**354-3. Covering.** Raceway coverings shall comply with (a) through (d) below.

**(a) Raceways Not Over 4 Inches (102 mm) Wide.** Half-round and flat-top raceways not over 4 inches (102 mm) in width shall have not less than  $\frac{3}{4}$  inch (19 mm) of concrete or wood above the raceway.

*Exception: As permitted in (c) below for flat-top raceways.*

**(b) Raceways Over 4 Inches (102 mm) Wide but Not Over 8 Inches (203 mm) Wide.** Flat-top raceways over 4 inches (102 mm) but not over 8 inches (203 mm) wide with a minimum of 1 inch (25.4 mm) spacing between raceways shall be covered with concrete to a depth of not less than 1 inch (25.4 mm). Raceways spaced less than 1 inch (25.4 mm) apart shall be covered with concrete to a depth of  $1\frac{1}{2}$  inches (38 mm).

**(c) Trench-type Raceways Flush with Concrete.** Trench-type flush raceways with removable covers shall be permitted to be laid flush with the floor surface. Such approved raceways shall be so designed that the cover plates will provide adequate mechanical protection and rigidity equivalent to junction box covers.

**(d) Other Raceways Flush with Concrete.** In office occupancies, approved metal flat-top raceways, if not over 4 inches (102 mm) in width, shall be permitted to be laid flush with the concrete floor surface provided they are covered with substantial linoleum not less than  $\frac{1}{16}$  inch (1.59 mm) in thickness or with equivalent floor covering. Where more than one and not more than three single raceways are each installed flush with the concrete, they shall be contiguous with each other and joined to form a rigid assembly.

**354-4. Size of Conductors.** No conductor larger than that for which the raceway is designed shall be installed in underfloor raceways.

**354-5. Maximum Number of Conductors in Raceway.** The combined cross-sectional area of all conductors or cables shall not exceed 40 percent of the interior cross-sectional area of the raceway.

(FPN): For conductor cross-sectional area see Tables 5, 5A, 6, 7, 8 and the applicable Notes to Tables at the beginning of Chapter 9.

**354-6. Splices and Taps.** Splices and taps shall be made only in junction boxes.

For the purposes of this section, so-called loop wiring (continuous, unbroken conductor connecting the individual outlets) shall not be considered to be a splice or tap.

*Exception: Splices and taps shall be permitted in trench-type flush raceway having a removable cover that is accessible after installation. The conductors, including splices and taps, shall not fill the raceway more than 75 percent of its area at that point.*

**354-7. Discontinued Outlets.** When an outlet is abandoned, discontinued, or removed, the sections of circuit conductors supplying the outlet shall be removed from the raceway. No splices or re-insulated conductors, such as would be the case with abandoned outlets on loop wiring, shall be allowed in raceways.

**354-8. Laid in Straight Lines.** Underfloor raceways shall be laid so that a straight line from the center of one junction box to the center of the next junction box will coincide with the center line of the raceway system. Raceways shall be firmly held in place to prevent disturbing this alignment during construction.

**354-9. Markers at Ends.** A suitable marker shall be installed at or near each end of each straight run of raceways to locate the last insert.

**354-10. Dead Ends.** Dead ends of raceways shall be closed.

**354-13. Junction Boxes.** Junction boxes shall be leveled to the floor grade and sealed to prevent the free entrance of water or concrete. Junction boxes used with metal raceways shall be metal and shall be electrically continuous with the raceways.

**354-14. Inserts.** Inserts shall be leveled and sealed to prevent the entrance of concrete. Inserts used with metal raceways shall be metal and shall be electrically continuous with the raceway. Inserts set in or on fiber raceways before the floor is laid shall be mechanically secured to the raceway. Inserts set in fiber raceways after the floor is laid shall be screwed into the raceway. In cutting through the raceway wall and setting inserts, chips and other dirt shall not be allowed to remain in the raceway, and tools shall be used that are so designed as to prevent the tool from entering the raceway and damaging conductors that may be in place.

**354-15. Connections to Cabinets and Wall Outlets.** Connections between raceways and distribution centers and wall outlets shall be made by means of flexible metal conduit when not installed in concrete, rigid metal conduit, intermediate metal conduit, electrical metallic tubing, or approved fittings.



Where a metallic underfloor raceway system provides for the termination of an equipment grounding conductor, rigid nonmetallic conduit or electrical nonmetallic tubing shall be permitted.

## ARTICLE 356 — CELLULAR METAL FLOOR RACEWAYS

**356-1. Definitions.** For the purposes of this article, a "cellular metal floor raceway" shall be defined as the hollow spaces of cellular metal floors, together with suitable fittings, which may be approved as enclosures for electric conductors. A "cell" shall be defined as a single, enclosed tubular space in a cellular metal floor member, the axis of the cell being parallel to the axis of the metal floor member. A "header" shall be defined as a transverse raceway for electric conductors, providing access to predetermined cells of a cellular metal floor, thereby permitting the installation of electric conductors from a distribution center to the cells.

**356-2. Use.** Conductors shall not be installed in cellular metal floor raceways (1) where subject to corrosive vapor; (2) in any hazardous (classified) location except Class I, Division 2 locations as permitted in the Exception to Section 501-4(b); nor (3) in commercial garages, other than for supplying ceiling outlets or extensions to the area below the floor but not above.

(FPN): See Section 300-8 for installation of conductors with other systems.

**356-3. Other Articles.** Cellular metal floor raceways shall comply with the applicable provisions of Article 300.

### A. Installation

**356-4. Size of Conductors.** No conductor larger than No. 1/0 shall be installed, except by special permission.

**356-5. Maximum Number of Conductors in Raceway.** The combined cross-sectional area of all conductors or cables shall not exceed 40 percent of the interior cross-sectional area of the cell or header.

(FPN): For conductor cross-sectional area see Tables 5, 5A, 6, 7, 8 and the applicable Notes to Tables at the beginning of Chapter 9.

**356-6. Splices and Taps.** Splices and taps shall be made only in header access units or junction boxes.

For the purposes of this section, so-called loop wiring (continuous unbroken conductor connecting the individual outlets) shall not be considered to be a splice or tap.

**356-7. Discontinued Outlets.** When an outlet is abandoned, discontinued, or removed, the sections of circuit conductors supplying the outlet shall be removed from the raceway. No splices or reinsulated conductors, such as would be the case with abandoned outlets on loop wiring, shall be allowed in raceways.

**356-8. Markers.** A suitable number of markers shall be installed for the future locating of cells.

**356-9. Junction Boxes.** Junction boxes shall be leveled to the floor grade and sealed against the free entrance of water or concrete. Junction boxes used with these raceways shall be of metal and shall be electrically continuous with the raceway.

**356-10. Inserts.** Inserts shall be leveled to the floor grade and sealed against the entrance of concrete. Inserts shall be of metal and shall be electrically continuous with the raceway. In cutting through the cell wall and setting inserts, chips and other dirt shall not be allowed to remain in the raceway, and tools shall be used that are designed to prevent the tool from entering the cell and damaging the conductors.

**356-11. Connection to Cabinets and Extensions from Cells.** Connections between raceways and distribution centers and wall outlets shall be made by means of flexible metal conduit when not installed in concrete, rigid metal conduit, intermediate metal conduit, electrical metallic tubing, or approved fittings. Where there are provisions for the termination of an equipment grounding conductor, nonmetallic conduit or electrical nonmetallic tubing shall be permitted.

#### **B. Construction Specifications**

**356-12. General.** Cellular metal floor raceways shall be so constructed that adequate electrical and mechanical continuity of the complete system will be secured. They shall provide a complete enclosure for the conductors. The interior surfaces shall be free from burrs and sharp edges, and surfaces over which conductors are drawn shall be smooth. Suitable bushings or fittings having smooth rounded edges shall be provided where conductors pass.

### **ARTICLE 358 — CELLULAR CONCRETE FLOOR RACEWAYS**

**358-1. Scope.** This article covers cellular concrete floor raceways, the hollow spaces in floors constructed of precast cellular concrete slabs, together with suitable metal fittings designed to provide access to the floor cells.

**358-2. Definitions.** A "cell" shall be defined as a single, enclosed tubular space in a floor made of precast cellular concrete slabs, the direction of the cell being parallel to the direction of the floor member. A "header" shall be defined as transverse metal raceways for electric conductors, providing access to predetermined cells of a precast cellular concrete floor, thereby permitting the installation of electric conductors from a distribution center to the floor cells.

**358-3. Other Articles.** Cellular concrete floor raceways shall comply with the applicable provisions of Article 300.

**358-4. Use.** Conductors shall not be installed in precast cellular concrete floor raceways (1) where subject to corrosive vapor; (2) in hazardous (classified) locations except Class I, Division 2 locations as permitted in the Exception to Section 501-4(b); nor (3) in commercial garages, other than for supplying ceiling outlets or extensions to the area below the floor but not above.

(FPN): See Section 300-8 for installation of conductors with other systems.

**358-5. Header.** The header shall be installed in a straight line, at right angles to the cells. The header shall be mechanically secured to the top of the precast cellular concrete floor. The end joints shall be closed by a metallic closure fitting and sealed against the entrance of concrete. The header shall be electrically continuous throughout its entire length and shall be electrically bonded to the enclosure of the distribution center.

**358-6. Connection to Cabinets and Other Enclosures.** Connections from headers to cabinets and other enclosures shall be made by means of metal raceways and approved fittings.

**358-7. Junction Boxes.** Junction boxes shall be leveled to the floor grade, and sealed against the free entrance of water or concrete. Junction boxes shall be of metal and shall be mechanically and electrically continuous with the header.

**358-8. Markers.** A suitable number of markers shall be installed for the future location of cells.

**358-9. Inserts.** Inserts shall be leveled and sealed against the entrance of concrete. Inserts shall be of metal and shall be fitted with receptacles of the grounded type. A grounding conductor shall connect the insert receptacles to a positive ground connection provided on the header. In cutting through the cell wall for setting inserts or other purposes (such as providing access openings between header and cells), chips and other dirt shall not be allowed to remain in the raceway, and the tool used shall be so designed as to prevent the tool from entering the cell and damaging the conductors.

**358-10. Size of Conductors.** No conductor larger than No. 1/0 shall be installed, except by special permission.

**358-11. Maximum Number of Conductors.** The combined cross-sectional area of all conductors or cables shall not exceed 40 percent of the cross-sectional area of the cell or header.

**358-12. Splices and Taps.** Splices and taps shall be made only in header access units or junction boxes.

For the purposes of this section, so-called loop wiring (continuous unbroken conductor connecting the individual outlets) shall not be considered to be a splice or tap.

**358-13. Discontinued Outlets.** When an outlet is abandoned, discontinued, or removed, the sections of circuit conductors supplying the outlet shall be removed from the raceway. No splices or reinsulated conductors, such as would be the case with abandoned outlets on loop wiring, shall be allowed in raceways.

**ARTICLE 362 — WIREWAYS**

**362-1. Definition.** Wireways are sheet-metal troughs with hinged or removable covers for housing and protecting electric wires and cable and in which conductors are laid in place after the wireway has been installed as a complete system.

**362-2. Use.** Wireways shall be permitted only for exposed work. Wireways installed in wet locations shall be of raintight construction. Wireways shall not be installed (1) where subject to severe physical damage or corrosive vapor, nor (2) in any hazardous (classified) location, except Class I, Division 2 and Class II, Division 2 locations as permitted in Sections 501-4(b) and 502-4(b).

*Exception: Wireways shall be permitted in concealed spaces in accordance with Section 640-4, Exception c.*

**362-3. Other Articles.** Installations of wireways shall comply with the applicable provisions of Article 300.

**362-4. Size of Conductors.** No conductor larger than that for which the wireway is designed shall be installed in any wireway.

**362-5. Number of Conductors.** Wireways shall not contain more than thirty current-carrying conductors at any cross section. Conductors for signaling circuits or controller conductors between a motor and its starter and used only for starting duty shall not be considered as current-carrying conductors.

The sum of cross-sectional areas of all contained conductors at any cross section of the wireway shall not exceed 20 percent of the interior cross-sectional area of the wireway.

The derating factors specified in Note 8 (a) to Tables 310-16 through 310-31 shall not be applicable to the thirty current-carrying conductors at 20 percent fill specified above.

*Exception No. 1: Where the derating factors specified in Note 8 (a) to Tables 310-16 through 310-31 are applied, the number of current-carrying conductors shall not be limited but the sum of the cross-sectional area of all contained conductors at any cross section of the wireway shall not exceed 20 percent of the interior cross-sectional area of the wireway.*

*Exception No. 2: As provided in Section 520-5, the thirty conductor limitation does not apply for theaters and similar locations.*

*Exception No. 3: As provided in Section 620-32, the 20 percent fill limitation does not apply for elevators and dumbwaiters.*

(FPN): For conductor cross-sectional area see Tables 5, 5A, 6, 7, 8 and the applicable Notes to Tables at the beginning of Chapter 9.

**362-6. Splices and Taps.** Splices and taps shall be permitted within a wireway provided they are accessible. The conductors, including splices and taps, shall not fill the wireway to more than 75 percent of its area at that point.

**362-7. Supports.** Wireways shall be securely supported at intervals not exceeding 5 feet (1.52 m), unless specially approved for supports at greater

intervals, but in no case shall the distance between supports exceed 10 feet (3.05 m).

*Exception: Vertical runs of wireways shall be securely supported at intervals not exceeding 15 feet (4.57 m) and shall have not more than one joint between supports. Adjoining wireway sections shall be securely fastened together to provide a rigid joint.*

**362-8. Extension Through Walls.** Unbroken lengths of wireway shall be permitted to pass transversely through walls if in unbroken lengths where passing through.

**362-9. Dead Ends.** Dead ends of wireways shall be closed.

**362-10. Extensions from Wireways.** Extensions from wireways shall be made with rigid or flexible metal conduit, intermediate metal conduit, rigid nonmetallic conduit, electrical nonmetallic tubing, electrical metallic tubing, surface metal raceway, Type MI cable, liquidtight flexible metal conduit, cord pendants, or metal-clad cable. Where rigid nonmetallic conduit or electrical nonmetallic tubing is used, connection of equipment grounding conductors in the nonmetallic raceway to the wireway shall comply with Sections 250-113 and 250-118.

**362-11. Marking.** Wireways shall be marked so that their manufacturer's name or trademark will be visible after installation.

**362-12. Grounding.** Grounding shall be according to the provisions of Article 250.

## ARTICLE 363 — FLAT CABLE ASSEMBLIES

### Type FC

**363-1. Definition.** Type FC, a flat cable assembly, is an assembly of parallel conductors formed integrally with an insulating material web specifically designed for field installation in surface metal raceway.

**363-2. Other Articles.** In addition to the provisions of this article, installation of Type FC cable shall conform with the applicable provisions of Articles 210, 220, 250, 300, 310, and 352.

**363-3. Uses Permitted.** Flat cable assemblies shall be permitted only as branch circuits to supply suitable tap devices for lighting, small appliances, or small power loads. Flat cable assemblies shall be installed for exposed work only. Flat cable assemblies shall be installed in locations where they will not be subjected to severe physical damage.

**363-4. Uses Not Permitted.** Flat cable assemblies shall not be installed: (1) where subject to corrosive vapors unless suitable for the application; (2) in hoistways; (3) in any hazardous (classified) location; or (4) outdoors or in wet or damp locations unless identified for use in wet locations.

**363-5. Installation.** Flat cable assemblies shall be installed in the field only in surface metal raceways identified for the use. The channel portion of the surface metal raceway systems shall be installed as complete systems before the flat cable assemblies are pulled into the raceways.

**363-6. Number of Conductors.** The flat cable assemblies shall consist of either two, three, or four conductors.

**363-7. Size of Conductors.** Flat cable assemblies shall have conductors of No. 10 special stranded copper wires.

**363-8. Conductor Insulation.** The entire flat cable assembly shall be formed to provide a suitable insulation covering all of the conductors and using one of the materials recognized in Table 310-13 for general branch-circuit wiring.

**363-9. Splices.** Splices shall be made in approved junction boxes using approved wiring methods.

**363-10. Taps.** Taps shall be made between any phase conductor and the neutral or any other phase conductor by means of devices and fittings identified for the use. Tap devices shall be rated at not less than 15 amperes or more than 300 volts and they shall be color-coded in accordance with the requirements of Section 363-20.

**363-11. Dead Ends.** Each flat cable assembly dead end shall be terminated in an end-cap device identified for the use.

The dead-end fitting for the enclosing metal surface raceway shall be identified for the use.

**363-12. Fixture Hangers.** Fixture hangers installed with the flat cable assemblies shall be identified for the use.

**363-13. Fittings.** Fittings to be installed with flat cable assemblies shall be designed and installed to prevent physical damage to the cable assemblies.

**363-14. Extensions.** All extensions from flat cable assemblies shall be made by approved wiring methods, within the junction boxes, installed at either end of the flat cable assembly runs.

**363-15. Supports.** The flat cable assemblies shall be supported by means of their special design features, within the surface metal raceways.

The surface metal raceways shall be supported as required for the specific raceway to be installed.

**363-16. Rating.** The rating of the branch circuit shall not exceed 30 amperes.

**363-17. Marking.** In addition to the provisions of Section 310-11, Type FC cable shall have the temperature rating durably marked on the surface at intervals not exceeding 24 inches (610 mm).

**363-18. Protective Covers.** When a flat cable assembly is installed less than 8 feet (2.44 m) from the floor, it shall be protected by a metal cover identified for the use.

**363-19. Identification.** The grounded conductor shall be identified throughout its length by means of a distinctive and durable white or natural gray marking.

**363-20. Terminal Block Identification.** Terminal blocks identified for the use shall have distinctive and durable markings for color or word coding. The neutral section shall have a white marking or other suitable designation. The next adjacent section of the terminal block shall have a black marking or other suitable designation. The next section shall have a red marking or other suitable designation. The final or outer section, opposite the neutral section of the terminal block, shall have a blue marking or other suitable designation.

## ARTICLE 364 — BUSWAYS

### A. General Requirements

**364-1. Scope.** This article covers service-entrance, feeder, and branch-circuit busways and associated fittings.

**364-2. Definition.** For the purpose of this article a busway is considered to be a grounded metal enclosure containing factory mounted, bare or insulated conductors which are usually copper or aluminum bars, rods, or tubes.

(FPN): For cablebus, refer to Article 365.

**364-3. Other Articles.** Installations of busways shall comply with the applicable provisions of Article 300.

#### **364-4. Use.**

**(a) Use Permitted.** Busways shall be installed only where they are located in the open and are visible.

*Exception: Busways shall be permitted to be installed behind panels if means of access are provided and if all the following conditions are met.*

*a. No overcurrent devices are installed on the busway other than for an individual fixture.*

*b. The space behind the access panels is not used for air-handling purposes.*

*c. The busway is totally enclosed, nonventilating type.*

*d. Busway is so installed that the joints between sections and fittings are accessible for maintenance purposes.*

**(b) Use Prohibited.** Busways shall not be installed: (1) where subject to severe physical damage or corrosive vapors; (2) in hoistways; (3) in any hazardous (classified) location, unless specifically approved for such use [see Section 501-4(b)]; nor (4) outdoors or in wet or damp locations unless identified for such use.

**364-5. Support.** Busways shall be securely supported at intervals not exceeding 5 feet (1.52 m) unless otherwise designed and marked.

**364-6. Through Walls and Floors.** It shall be permissible to extend unbroken lengths of busway through dry walls. It shall be permissible to extend

busways vertically through dry floors if totally enclosed (unventilated) where passing through and for a minimum distance of 6 feet (1.83 m) above the floor to provide adequate protection from physical damage.

**364-7. Dead Ends.** A dead end of a busway shall be closed.

**364-8. Branches from Busways.** Branches from busways shall be made with busways, rigid metal conduit, intermediate metal conduit, rigid non-metallic conduit, electrical nonmetallic tubing, flexible metal conduit, electrical metallic tubing, metal surface raceway or metal-clad cable; or with suitable cord assemblies approved for hard usage for the connection of portable equipment or for the connection of stationary equipment to facilitate their interchange. Flexible cord assembly connections shall be permitted to be made directly to the load end terminals of a busway plug-in device, providing the connection includes a suitable tension take-up device on the cord. Where a nonmetallic raceway is used, connection of equipment grounding conductors in the nonmetallic raceway to the busway shall comply with Sections 250-113 and 250-118.

**364-9. Overcurrent Protection.** Overcurrent protection shall be provided in accordance with Sections 364-10 through 364-14.

**364-10. Rating of Overcurrent Protection — Feeders and Subfeeders.** Where the allowable current rating of the busway does not correspond to a standard rating of the overcurrent device, the next higher rating shall be permitted.

**364-11. Reduction in Size of Busway.** Omission of overcurrent protection shall be permitted at points where busways are reduced in size, provided that the smaller busway does not extend more than 50 feet (15.2 m) and has a current rating at least equal to  $\frac{1}{3}$  the rating or setting of the overcurrent device next back on the line, and provided further that such busway is free from contact with combustible material.

**364-12. Subfeeder or Branch Circuits.** Where a busway is used as a feeder, devices or plug-in connections for tapping off subfeeder or branch circuits from the busway shall contain the overcurrent devices required for the protection of the subfeeder or branch circuits. The plug-in device shall consist of an externally operable circuit breaker or an externally operable fusible switch. Where such devices are mounted out of reach and contain disconnecting means, suitable means such as ropes, chains, or sticks shall be provided for operating the disconnecting means from the floor.

*Exception No. 1: As permitted in Section 240-21 for taps.*

*Exception No. 2: For fixed or semi-fixed lighting fixtures, where the branch-circuit overcurrent device is part of the fixture cord plug on cord-connected fixtures.*

*Exception No. 3: Where fixtures without cords are plugged directly into the busway and the overcurrent device is mounted on the fixture.*

**364-13. Rating of Overcurrent Protection — Branch Circuits.** A busway shall be permitted as a branch circuit of any one of the types described in Article 210. When so used, the rating or setting of the overcurrent device protecting the busway shall determine the ampere rating of the branch



circuit, and the circuit shall in all respects conform with the requirements of Article 210 that apply to branch circuits of that rating.

**364-14. Length of Busways Used as Branch Circuits.** Busways which are used as branch circuits and which are so designed that loads can be connected at any point shall be limited to such lengths as will provide that in normal use the circuits will not be overloaded.

**364-15. Marking.** Busways shall be marked with the voltage and current rating for which they are designed, and with the manufacturer's name or trademark in such manner as to be visible after installation.

### B. Requirements for Over 600 Volts, Nominal

**364-21. Identification.** Each bus run shall be provided with a permanent nameplate on which the following information shall be provided: (1) rated voltage; (2) rated continuous current; if bus is forced-cooled, both the normal forced-cooled rating and the self-cooled (not forced-cooled) rating for the same temperature rise shall be given; (3) rated frequency; (4) rated impulse withstand voltage; (5) rated 60-Hz withstand voltage (dry); (6) rated momentary current; and (7) manufacturer's name or trademark.

(FPN): See Switchgear Assemblies, ANSI C37.20-1969 (R1981), for construction and testing requirements for metal-enclosed buses.

**364-22. Grounding.** Metal-enclosed bus shall be grounded in accordance with Article 250.

**364-23. Adjacent and Supporting Structures.** Metal-enclosed busways shall be installed so that temperature rise from induced circulating currents in any adjacent metallic parts will not be hazardous to personnel or constitute a fire hazard.

**364-24. Neutral.** Neutral bus, where required, shall be sized to carry all neutral load current, including harmonic currents, and shall have adequate momentary and short-circuit rating consistent with system requirements.

**364-25. Barriers and Seals.** Bus runs having sections located both inside and outside of buildings shall have a vapor seal at the building wall to prevent interchange of air between indoor and outdoor sections.

Fire barriers shall be provided where fire walls, floors, or ceilings are penetrated.

*Exception: Vapor seals shall not be required in forced-cooled bus.*

**364-26. Drain Facilities.** Drain plugs, filter drains, or similar methods shall be provided to remove condensed moisture from low points in bus run.

**364-27. Ventilated Bus Enclosures.** Ventilated bus enclosures shall be installed in accordance with Article 710, Part D, unless designed so that foreign objects inserted through any opening will be deflected from energized parts.

**364-28. Terminations and Connections:** Where bus enclosures terminate at machines cooled by flammable gas, seal-off bushings, baffles, or other means shall be provided to prevent accumulation of flammable gas in the bus enclosures.

Flexible or expansion connections shall be provided in long, straight runs of bus to allow for temperature expansion or contraction, or where the bus run crosses building vibration insulation joints.

All conductor termination and connection hardware shall be accessible for installation, connection, and maintenance.

**364-29. Switches.** Switching devices or disconnecting links provided in the bus run shall have the same momentary rating as the bus. Disconnecting links shall be plainly marked to be removable only when bus is de-energized. Switching devices which are not load break shall be interlocked to prevent operation under load, and disconnecting link enclosures shall be interlocked to prevent access to energized parts.

**364-30. Low-Voltage Wiring.** Secondary control devices and wiring which are provided as part of the metal-enclosed bus run shall be insulated by fire-retardant barriers from all primary circuit elements with the exception of short lengths of wire, such as at instrument transformer terminals.

## ARTICLE 365 — CABLEBUS

**365-1. Definition.** Cablebus is an approved assembly of insulated conductors with fittings and conductor terminations in a completely enclosed, ventilated protective metal housing. The assembly is designed to carry fault current and to withstand the magnetic forces of such current.

(FPN): Cablebus is ordinarily assembled at the point of installation from components furnished or specified by the manufacturer in accordance with instructions for the specific job.

### 365-2. Use.

(a) **600 Volts or Less.** Cablebus shall be permitted at any voltage or current for which spaced conductors are rated and shall be installed for exposed work only. Cablebus installed outdoors or in corrosive, wet, or damp locations shall be identified for such use. Cablebus shall not be installed in hoistways or hazardous (classified) locations unless specifically approved for such use. Cablebus shall be permitted to be used for branch circuits, feeders, and services.

Cablebus framework, where adequately bonded, shall be permitted as the equipment grounding conductor for branch circuits and feeders.

(b) **Over 600 Volts.** Cablebus shall be permitted for systems in excess of 600 volts, nominal. See Section 710-3(a).

### 365-3. Conductors.

(a) **Types of Conductors.** The current-carrying conductors in cablebus shall have an insulation rating of 75°C or higher of an approved type and suitable for the application in accordance with Articles 310 and 710.

(b) **Ampacity of Conductors.** The ampacity of conductors in cablebus shall be in accordance with Tables 310-17 and 310-19.

(c) **Size and Number of Conductors.** The size and number of conductors shall be that for which the cablebus is designed, and in no case smaller than No. 1/0.

(d) **Conductor Supports.** The insulated conductors shall be supported on blocks or other mounting means designed for the purpose.

The individual conductors in a cablebus shall be supported at intervals not greater than 3 feet (914 mm) for horizontal runs and 1½ feet (457 mm) for vertical runs. Vertical and horizontal spacing between supported conductors shall not be less than one conductor diameter at the points of support.

**365-5. Overcurrent Protection.** When the allowable ampacity of cablebus conductors does not correspond to a standard rating of an overcurrent device, the next higher ampere-rated overcurrent device shall be permitted.

**365-6. Support and Extension Through Walls and Floors.**

(a) **Support.** Cablebus shall be securely supported at intervals not exceeding 12 feet (3.66 m).

*Exception: Where spans longer than 12 feet (3.66 m) are required, the structure shall be specifically designed for the required span length.*

(b) **Transversely Routed.** It shall be permissible to extend cablebus transversely through partitions or walls, other than fire walls, provided the section within the wall is continuous, protected against physical damage, and unventilated.

(c) **Through Dry Floors and Platforms.** Except where fire stops are required, it shall be permissible to extend cablebus vertically through dry floors and platforms, provided the cablebus is totally enclosed at the point where it passes through the floor or platform and for a distance of 6 feet (1.83 m) above the floor or platform.

(d) **Through Floors and Platforms in Wet Locations.** Except where fire stops are required, it shall be permissible to extend cablebus vertically through floors and platforms in wet locations where (1) there are curbs or other suitable means to prevent waterflow through the floor or platform opening, and (2) where the cablebus is totally enclosed at the point where it passes through the floor or platform and for a distance of 6 feet (1.83 m) above the floor or platform.

**365-7. Fittings.** A cablebus system shall include approved fittings for: (1) changes in horizontal or vertical direction of the run; (2) dead ends; (3) terminations in or on connected apparatus or equipment or the enclosures for such equipment; and (4) additional physical protection where required, such as guards for severe mechanical exposure.

**365-8. Conductor Terminations.** Approved terminating means shall be used for connections to cablebus conductors.

**365-9. Grounding.** Sections of cablebus shall be electrically bonded either by inherent design of the mechanical joints or by applied bonding means.

(FPN): See Section 250-75 for bonding of metal noncurrent-carrying parts.

A cablebus installation shall be grounded in accordance with Sections 250-32 and 250-33.

**365-10. Marking.** Each section of cablebus shall be marked with the manufacturer's name or trade designation and the maximum diameter, number, voltage rating, and ampacity of the conductors to be installed. Markings shall be so located as to be visible after installation.

## ARTICLE 370 — OUTLET, DEVICE, PULL AND JUNCTION BOXES, CONDUIT BODIES AND FITTINGS

### A. Scope and General

**370-1. Scope.** This article covers the installation and use of all boxes, conduit bodies, and fittings as required by Section 300-15, and boxes, conduit bodies, and fittings referred to in Section 300-15 used as outlet, junction, or pull boxes, depending on their use. Cast, sheet metal, nonmetallic, and other boxes such as FS, FD, and larger boxes are not classified as conduit bodies. Fittings such as capped elbows and service-entrance elbows are not classified as conduit bodies.

(FPN): For systems over 600 volts, nominal, see Part D of this article.

**370-2. Round Boxes.** Round boxes shall not be used where conduits or connectors requiring the use of locknuts or bushings are to be connected to the side of the box.

**370-3. Nonmetallic Boxes.** Nonmetallic boxes shall be permitted only with open wiring on insulators, concealed knob-and-tube wiring, nonmetallic-sheathed cable, electrical nonmetallic tubing, and with rigid nonmetallic conduit.

In addition thereto, nonmetallic boxes over 100 cubic inches shall be permitted to be used with metal raceways and metal-sheathed cables. Integral bonding means shall be provided between all threaded entries for metal raceways or metal-sheathed cables.

**370-4. Metal Boxes.** All metal boxes shall be grounded in accordance with the provisions of Article 250.

### B. Installation

**370-5. Damp, Wet, or Hazardous (Classified) Locations.**

(a) **Damp or Wet Locations.** In damp or wet locations, boxes, conduit bodies, and fittings shall be so placed or equipped as to prevent moisture from entering or accumulating within the box, conduit body, or fitting. Boxes, conduit bodies, and fittings installed in wet locations shall be listed for use in wet locations.

(b) **Hazardous (Classified) Locations.** Installations in hazardous (classified) locations shall conform to Articles 500 through 517.

(FPN): For boxes in floors, see Section 370-17(b).

(FPN): For protection against corrosion, see Section 300-6.

**370-6. Number of Conductors in Outlet, Device, and Junction Boxes, and Conduit Bodies.** Boxes shall be of sufficient size to provide free space for all conductors enclosed in the box.

The provisions of this section shall not apply to terminal housings supplied with motors. See Section 430-12.

Boxes and conduit bodies containing conductors, size No. 4 or larger, shall also comply with the provisions of Section 370-18.

(a) **Standard Boxes.** The maximum number of conductors permitted in standard boxes shall be as is listed in Table 370-6(a). See Section 370-18 where boxes or conduit bodies are used as junction or pull boxes.

(1) Table 370-6(a) shall apply where no fittings or devices, such as fixture studs, cable clamps, hickies, switches, or receptacles, are contained in the box and where no grounding conductors are part of the wiring within the box. Where one or more of these types of fittings, such as fixture studs, cable clamps, or hickies are contained in the box, the number of conductors shown in the table shall be reduced by one for each type of fitting; an additional deduction of one conductor shall be made for each strap containing one or more devices; and a further deduction of one conductor shall be made for one or more grounding conductors entering the box. Where a second set of equipment grounding conductors, as permitted by Section 250-74, Exception No. 4, is present in the box, then an additional deduction of one conductor shall be made. A conductor running through the box shall be counted as one conductor, and each conductor originating outside of the box and terminating inside the box is counted as one conductor. Conductors, no part of which leaves the box, shall not be counted. The volume of a wiring enclosure (box) shall be the total volume of the assembled sections, and, where used, the space provided by plaster rings, domed covers, extension rings, etc., that are marked with their volume in cubic inches, or are made from boxes the dimensions of which are listed in Table 370-6(a).

(2) For combinations of conductor sizes shown in Table 370-6(a), the maximum number of conductors permitted shall be computed using the volume per conductor listed in Table 370-6(b), with the deductions provided for in Section 370-6(a)(1) and these volume deductions shall be based on the largest conductor entering the box. The maximum number and size of conductors listed in Table 370-6(a) shall not be exceeded.

(b) **Other Boxes.** Boxes 100 cubic inches or less other than those described in Table 370-6(a), conduit bodies having provision for more than two conduit entries and nonmetallic boxes shall be durably and legibly marked by the manufacturer with their cubic inch capacity. The maximum number of conductors permitted shall be computed using the volume per conductor listed in Table 370-6(b), with the deductions provided for in Section 370-6(a)(1), and these volume deductions shall be based on the largest conductor entering the box. Boxes described in Table 370-6(a) that have a larger cubic inch capacity than is designated in the table shall be permitted to have their cubic inch capacity marked as required by this section and the maximum number of conductors permitted shall be computed using the volume per conductor listed in Table 370-6(b).

(c) **Conduit Bodies.** Conduit bodies enclosing No. 6 conductors or smaller shall have a cross-sectional area not less than twice the cross-sectional area of the largest conduit to which it is attached. The maximum number of conductors permitted shall be the maximum number permitted by Table 1, Chapter 9, for the conduit to which it is attached.

Conduit bodies having provisions for less than three conduit entries shall not contain splices, taps, or devices unless they comply with the provisions of Section 370-6(b) and are supported in a rigid and secure manner.

Table 370-6(a). Metal Boxes

Box Dimension, Inches Trade Size or Type	Min. Cu. In. Cap.	Maximum Number of Conductors						
		No. 18	No. 16	No. 14	No. 12	No. 10	No. 8	No. 6
4 x 1½ Round or Octagonal	12.5	8	7	6	5	5	4	0
4 x 1½ Round or Octagonal	15.5	10	8	7	6	6	5	0
4 x 2¼ Round or Octagonal	21.5	14	12	10	9	8	7	0
4 x 1½ Square	18.0	12	10	9	8	7	6	0
4 x 1½ Square	21.0	14	12	10	9	8	7	0
4 x 2¼ Square	30.3	20	17	15	13	12	10	6*
4 <sup>11</sup> / <sub>16</sub> x 1½ Square	25.5	17	14	12	11	10	8	0
4 <sup>11</sup> / <sub>16</sub> x 1½ Square	29.5	19	16	14	13	11	9	0
4 <sup>11</sup> / <sub>16</sub> x 2¼ Square	42.0	28	24	21	18	16	14	6
3 x 2 x 1½ Device	7.5	5	4	3	3	3	2	0
3 x 2 x 2 Device	10.0	6	5	5	4	4	3	0
3 x 2 x 2½ Device	10.5	7	6	5	4	4	3	0
3 x 2 x 2½ Device	12.5	8	7	6	5	5	4	0
3 x 2 x 2¾ Device	14.0	9	8	7	6	5	4	0
3 x 2 x 3½ Device	18.0	12	10	9	8	7	6	0
4 x 2¼ x 1½ Device	10.3	6	5	5	4	4	3	0
4 x 2¼ x 1¾ Device	13.0	8	7	6	5	5	4	0
4 x 2¼ x 2¼ Device	14.5	9	8	7	6	5	4	0
3¾ x 2 x 2½ Masonry Box/Gang	14.0	9	8	7	6	5	4	0
3¾ x 2 x 3½ Masonry Box/Gang	21.0	14	12	10	9	8	7	0
FS—Minimum Internal Depth 1¼ Single Cover/Gang	13.5	9	7	6	6	5	4	0
FD—Minimum Internal Depth 2¾ Single Cover/Gang	18.0	12	10	9	8	7	6	3
FS—Minimum Internal Depth 1¼ Multiple Cover/Gang	18.0	12	10	9	8	7	6	0
FD—Minimum Internal Depth 2¾ Multiple Cover/Gang	24.0	16	13	12	10	9	8	4

\* Not to be used as a pull box. For termination only.

Table 370-6(b). Volume Required per Conductor

Size of Conductor	Free Space Within Box for Each Conductor
No. 18	1.5 cubic inches
No. 16	1.75 cubic inches
No. 14	2. cubic inches
No. 12	2.25 cubic inches
No. 10	2.5 cubic inches
No. 8	3. cubic inches
No. 6	5. cubic inches

**370-7. Conductors Entering Boxes, Conduit Bodies, or Fittings.** Conductors entering boxes, conduit bodies or fittings shall be protected from abrasion, and shall comply with (a) through (d) below.

(a) **Openings to Be Closed.** Openings through which conductors enter shall be adequately closed.

(b) **Metal Boxes, Conduit Bodies, and Fittings.** Where metal outlet boxes, conduit bodies or fittings are installed with open wiring or concealed knob-and-tube wiring, conductors shall enter through insulating bushings or, in dry places, through flexible tubing extending from the last insulating support and firmly secured to the box, conduit body or fitting. Where raceway or cable is installed with metal outlet boxes, conduit bodies or fittings, the raceway or cable shall be secured to such boxes, conduit bodies and fittings. Fittings such as capped elbows and service-entrance elbows shall not contain splices, taps, or devices and shall be of sufficient size to provide free space for all conductors enclosed in the fitting.

(c) **Nonmetallic Boxes.** Nonmetallic boxes shall be suitable for the lowest temperature rated conductor entering the box. Where nonmetallic boxes are used with open wiring or concealed knob-and-tube wiring, the conductors shall enter the box through individual holes. Where flexible tubing is used to encase the conductors, the tubing shall extend from the last insulating support to no less than  $\frac{1}{4}$  inch (6.35 mm) inside the box. Where nonmetallic-sheathed cable is used, the cable assembly, including the sheath, shall extend into the box no less than  $\frac{1}{4}$  inch (6.35 mm) through a nonmetallic-sheathed cable knockout opening. In all instances all permitted wiring methods shall be secured to the boxes.

*Exception: Where nonmetallic-sheathed cable is used with boxes no larger than a nominal size  $2\frac{1}{4}$  inch by 4 inch mounted in walls and where the cable is fastened within 8 inches (203 mm) of the box measured along the sheath and where the sheath extends into the box no less than  $\frac{1}{4}$  inch (6.35 mm), securing the cable to the box shall not be required.*

(d) **Conductors No. 4 AWG or Larger.** Installation shall comply with Section 373-6(c).

**370-8. Unused Openings.** Unused openings in boxes, conduit bodies and fittings shall be effectively closed to afford protection substantially equivalent to that of the wall of the box, conduit body or fitting. Metal plugs or plates used with nonmetallic boxes, conduit bodies or fittings shall be recessed at least  $\frac{1}{4}$  inch (6.35 mm) from the outer surface.

**370-9. Boxes Enclosing Flush Devices.** Boxes used to enclose flush devices shall be of such design that the devices will be completely enclosed on back and sides, and that substantial support for the devices will be provided. Screws for supporting the box shall not be used in attachment of the device contained therein.

**370-10. In Wall or Ceiling.** In walls or ceilings of concrete, tile, or other noncombustible material, boxes and fittings shall be so installed that the front edge of the box or fitting will not set back of the finished surface more than  $\frac{1}{4}$  inch (6.35 mm). In walls and ceilings constructed of wood or other combustible material, outlet boxes and fittings shall be flush with the finished surface or project therefrom.

**370-11. Repairing Plaster and Drywall or Plasterboard.** Plaster, drywall or plasterboard surfaces that are broken or incomplete shall be repaired so there

will be no gaps or open spaces greater than  $\frac{1}{8}$  inch (1.59 mm) at the edge of the box or fitting.

**370-12. Exposed Surface Extensions.** In making an exposed surface extension from an existing outlet of concealed wiring, a box or extension ring shall be mounted over the original box and mechanically secured to it. Extensions shall not be made from the cover. Where required, equipment grounding shall be in accordance with Article 250.

**370-13. Supports.** Enclosures within the scope of Article 370 shall be rigidly and securely fastened in place in accordance with (a) through (f) below.

(a) **Surface Mounting.** They shall be fastened to the surface upon which they are mounted unless such surface does not provide adequate support in which case they shall be supported in accordance with (b).

(b) **Structural Mounting.** They shall be rigidly supported from a structural member of the building either directly or by using a metal or wood brace. Support wires that do not provide rigid support shall not be permitted as the sole support.

(1) Nails, where used as a fastening means, shall be permitted to pass through the interior of the enclosure if located within  $\frac{1}{4}$  inch (6.35 mm) of the back or ends of the enclosure.

(2) Metal braces shall be protected against corrosion and formed from metal not less than .020 inch (508 micrometers) thick uncoated. Wood braces shall have a cross section not less than nominal 1 inch (25.4 mm) by 2 inch (50.8 mm).

(c) **Nonstructural Mounting.** It shall be permissible to make a flush installation in existing covered surfaces where adequate support is provided by clamps, anchors, or fittings. Framing members of suspended ceiling systems shall be permitted as the support if the framing members are adequately supported and securely fastened to each other and to the building structure. Enclosures so supported shall be fastened to the framing member by mechanical means such as bolts, screws, or rivets. Clips identified for use with the type of ceiling framing member(s) and enclosure(s) shall also be permitted.

(d) **Raceway Supported Enclosure(s), Without Devices.** Threaded enclosures not over 100 cubic inches that do not contain devices, receptacles or switches and do not support fixtures shall be considered to be adequately supported if two or more conduits are threaded into the enclosure wrenchtight and are supported within 3 feet (914 mm) of the enclosure on two or more sides so as to provide the rigid and secure installation intended by this section of the Code.

*Exception: Conduit or electrical metallic tubing shall be permitted to support conduit bodies provided the conduit bodies are not larger than the largest trade size of the conduit or electrical metallic tubing.*

Such enclosures shall also be considered to be adequately supported if they comply with subsection (e) following.

(e) **Raceway Supported Enclosures, With Devices.** Threaded enclosures not over 100 cubic inches that contain devices, receptacles or switches shall be considered to be adequately supported if two or more conduits are threaded into the enclosure wrenchtight and if each conduit is supported



within 18 inches (457 mm) of the enclosure so as to provide the rigid and secure installation intended by this section of the Code.

*Exception: Conduit shall be permitted to support conduit bodies provided the conduit bodies are not larger than the largest trade size of the conduit.*

**(f) Enclosure(s) in Concrete or Masonry.** Enclosure(s) shall be permitted to be supported by being embedded.

**(g) Nonthreaded Nonmetallic Conduit Supported Enclosures.** Nonthreaded nonmetallic enclosures shall be permitted to be installed in accordance with instructions contained in the listing or labeling provided the two or more conduit support distances comply with (d) or (e) above.

**(h) Pendant Boxes.** Boxes shall be supported from a multiconductor cable in some satisfactory manner that protects the conductors against strain, such as a strain relief connector threaded into a box with a hub.

**370-14. Depth of Outlet Boxes.** No box shall have an internal depth of less than ½ inch (12.7 mm). Boxes intended to enclose flush devices shall have an internal depth of not less than ⅝ inch (23.8 mm).

**370-15. Covers and Canopies.** In completed installations each outlet box shall have a cover, faceplate, or fixture canopy.

**(a) Nonmetallic or Metal Covers and Plates.** Nonmetallic or metal covers and plates shall be permitted with nonmetallic outlet boxes. Where metal covers or plates are used, they shall comply with the grounding requirements of Section 250-42.

(FPN): See Sections 410-18(a) and 410-56(c) for metal faceplates.

**(b) Exposed Combustible Wall or Ceiling Finish.** Where a fixture canopy or pan is used, any combustible wall or ceiling finish exposed between the edge of the canopy or pan and the outlet box shall be covered with noncombustible material.

**(c) Flexible Cord Pendants.** Covers of outlet boxes and conduit bodies having holes through which flexible cord pendants pass shall be provided with bushings designed for the purpose or shall have smooth, well-rounded surfaces on which the cords may bear. So-called hard-rubber or composition bushings shall not be used.

**370-17. Outlet Boxes.**

**(a) Boxes at Lighting Fixture Outlets.** Boxes used at lighting fixture outlets shall be designed for the purpose. At every outlet used exclusively for lighting, the box shall be so designed or installed that a lighting fixture may be attached.

**(b) Floor Boxes.** Boxes listed specifically for this application shall be used for receptacles located in the floor.

*Exception: Boxes located in elevated floors of show windows and similar locations where the authority having jurisdiction judges them to be free from physical damage, moisture, and dirt.*

**(c) Boxes at Fan Outlets.** Outlet boxes shall not be used as the sole support for ceiling (paddle) fans.

*Exception: Boxes listed for the application shall be permitted as the sole means of support.*

**370-18. Pull and Junction Boxes.** Boxes and conduit bodies used as pull or junction boxes shall comply with (a) through (d) of this section.

(a) **Minimum Size.** For raceways  $\frac{3}{4}$  inch trade size or larger, containing conductors of No. 4 or larger, and for cables containing conductors of No. 4 or larger, the minimum dimensions of pull or junction boxes installed in a raceway or cable run shall comply with the following:

(1) **Straight Pulls.** In straight pulls the length of the box shall not be less than eight times the trade diameter of the largest raceway.

(2) **Angle or U Pulls.** Where angle or U pulls are made, the distance between each raceway entry inside the box and the opposite wall of the box shall not be less than six times the trade diameter of the largest raceway. This distance shall be increased for additional entries by the amount of the maximum sum of the diameters of all other raceway entries in any one row on the same wall of the box. The row that provides the maximum distance shall be used in this calculation.

*Exception: Where a conduit or cable entry is in the wall of a box or conduit body opposite to a removable cover and where the distance from that wall to the cover is in conformance with the column for one wire per terminal in Table 373-6(a).*

The distance between raceway entries enclosing the same conductor shall not be less than six times the trade diameter of the larger raceway.

When transposing cable size into raceway size in (a)(1) and (a)(2) above, the minimum trade size raceway required for the number and size of conductors in the cable shall be used.

(3) Boxes of dimensions less than those required in (a)(1) and (a)(2) above shall be permitted for installations of combinations of conductors that are less than the maximum conduit fill (of conduits being used) permitted by Table 1, Chapter 9, provided the box has been approved for and is permanently marked with the maximum number and maximum size of conductors permitted.

*Exception: Terminal housings supplied with motors which shall comply with the provisions of Section 430-12.*

(b) **Conductors in Pull or Junction Boxes.** In pull boxes or junction boxes having any dimension over 6 feet (1.83 m), all conductors shall be cabled or racked up in an approved manner.

(FPN): See Section 373-6(c) for insulation of conductors at bushings.

(c) **Covers.** All pull boxes, junction boxes, conduit bodies, and fittings shall be provided with covers compatible with the box, conduit body or fitting construction and suitable for the conditions of use. Where metal covers are used, they shall comply with the grounding requirements of Section 250-42.

(d) **Permanent Barriers.** Where permanent barriers are installed in a box, each section shall be considered as a separate box.

**370-19. Junction, Pull and Outlet Boxes to Be Accessible.** Junction, pull and outlet boxes shall be so installed that the wiring contained in them can be rendered accessible without removing any part of the building or in underground circuits without excavating sidewalks, paving, earth, or other substance that is to be used to establish the finished grade.

*Exception: Listed boxes shall be permitted where covered by gravel, light aggregate, or noncohesive granulated soil if their location is effectively identified and accessible for excavation.*

### C. Construction Specifications

#### 370-20. Metal Boxes, Conduit Bodies, and Fittings.

(a) **Corrosion-Resistant.** Metal boxes, conduit bodies, and fittings shall be corrosion-resistant or shall be well galvanized, enameled, or otherwise properly coated inside and out to prevent corrosion.

(FPN): See Section 300-6 for limitation in the use of boxes and fittings protected from corrosion solely by enamel.

(b) **Thickness of Metal.** Sheet steel boxes not over 100 cubic inches in size shall be made from steel not less than 0.0625 inch (1.59 mm) thick. The wall of a malleable iron box and a die-cast or permanent-mold cast aluminum, brass or bronze box shall not be less than  $\frac{3}{32}$  inch (2.38 mm) thick. Other cast metal boxes shall have a wall thickness not less than  $\frac{1}{8}$  inch (3.17 mm).

(c) **Metal Boxes Over 100 Cubic Inches.** Metal boxes over 100 cubic inches in size shall be constructed so as to be of ample strength and rigidity. If of sheet steel the metal shall not be less than 0.053 inch (1.35 mm) uncoated.

(d) **Grounding Provisions.** A means shall be provided in each metal box, designed for use with nonmetallic raceways and nonmetallic cable systems, for the connection of an equipment grounding conductor.

**370-21. Covers.** Metal covers shall be of a thickness not less than that specified for the walls of the box or fitting of the same material and with which they are designed to be used, or shall be lined with firmly attached insulating material not less than  $\frac{1}{32}$  inch (0.79 mm) in thickness. Covers of porcelain or other approved insulating material shall be permitted if of such form and thickness as to afford the required protection and strength.

**370-22. Bushings.** Covers of outlet boxes, conduit bodies and outlet fittings having holes through which flexible cord pendants may pass shall be provided with approved bushings or shall have smooth, well-rounded surfaces, upon which the cord may bear. Where conductors other than flexible cord may pass through a metal cover, a separate hole equipped with a bushing of suitable insulating material shall be provided for each conductor. Such separate holes shall be connected by a slot as required by Section 300-20.

(FPN): For alternating current conductors, see Section 300-20(b).

**370-23. Nonmetallic Boxes.** Provisions for supports or other mounting means for nonmetallic boxes shall be outside of the box, or the box shall be so constructed as to prevent contact between the conductors in the box and the supporting screws.

**370-24. Marking.** All boxes and conduit bodies, covers, extension rings, plaster rings, and the like shall be durably and legibly marked with the manufacturer's name or trademark.

#### D. Pull and Junction Boxes for Use on Systems Over 600 Volts, Nominal

**370-50. General.** In addition to the generally applicable provisions of Article 370, the rules in Sections 370-51 and 370-52 shall apply.

**370-51. Size of Pull and Junction Boxes.** Pull and junction boxes shall provide adequate space and dimensions for the installation of conductors in accordance with the following:

(a) **For Straight Pulls.** The length of the box shall not be less than forty-eight times the outside diameter, over sheath, of the largest shielded or lead-covered conductor or cable entering the box. The length shall not be less than thirty-two times the outside diameter of the largest nonshielded conductor or cable.

(b) **For Angle or U Pulls.** The distance between each cable or conductor entry inside the box and the opposite wall of the box shall not be less than thirty-six times the outside diameter, over sheath, of the largest cable or conductor. This distance shall be increased for additional entries by the amount of the sum of the outside diameters, over sheath, of all other cables or conductor-entries through the same wall of the box.

The distance between a cable or conductor entry and its exit from the box shall be not less than thirty-six times the outside diameter, over sheath, of that cable or conductor.

*Exception No. 1: Where cables are nonshielded and not lead-covered, the distance of thirty-six times the outside diameter shall be permitted to be reduced to twenty-four times the outside diameter.*

*Exception No. 2: Where a conductor or cable entry is in the wall of a box opposite to a removable cover and where the distance from that wall to the cover is in conformance with the provisions of Section 300-34.*

*Exception No. 3: Terminal housings supplied with motors which shall comply with the provisions of Section 430-12.*

(c) **Removable Sides.** One or more sides of any pull box shall be removable.

#### **370-52. Construction and Installation Requirements.**

(a) **Corrosion Protection.** Boxes shall be made of material inherently resistant to corrosion or shall be suitably protected, both internally and externally, by enameling, galvanizing, plating, or other means.

(b) **Passing Through Partitions.** Suitable bushings, shields, or fittings having smooth rounded edges shall be provided where conductors or cables pass through partitions and at other locations where necessary.

(c) **Complete Enclosure.** Boxes shall provide a complete enclosure for the contained conductors or cables.

(d) **Wiring Is Accessible.** Boxes shall be so installed that the wiring is accessible without removing any part of the building. Working space shall be provided in accordance with Section 110-34.

(e) **Suitable Covers.** Boxes shall be closed by suitable covers securely fastened in place. Underground box covers that weigh over 100 pounds (43.6 kg) shall be considered as meeting this requirement. Covers for boxes shall be permanently marked "HIGH VOLTAGE." The marking shall be on the

outside of the box cover and shall be readily visible. Letters shall be block type at least  $\frac{1}{2}$  inch (12.7 mm) in height.

(f) **Suitable for Expected Handling.** Boxes and their covers shall be capable of withstanding the handling to which they may be subjected.

## ARTICLE 373 — CABINETS AND CUTOUT BOXES

**373-1. Scope.** This article covers the installation and construction specifications of cabinets, cutout boxes, and meter socket enclosures.

### A. Installation

**373-2. Damp, Wet, or Hazardous (Classified) Locations.**

(a) **Damp and Wet Locations.** In damp or wet locations, cabinets and cutout boxes of the surface type shall be so placed or equipped as to prevent moisture or water from entering and accumulating within the cabinet or cutout box, and shall be mounted so there is at least  $\frac{1}{4}$ -inch (6.35-mm) air space between the enclosure and the wall or other supporting surface. Cabinets or cutout boxes installed in wet locations shall be weatherproof.

(FPN): For protection against corrosion, see Section 300-6.

(b) **Hazardous (Classified) Locations.** Installations in hazardous (classified) locations shall conform to Articles 500 through 517.

**373-3. Position in Wall.** In walls of concrete, tile, or other noncombustible material, cabinets shall be so installed that the front edge of the cabinet will not set back of the finished surface more than  $\frac{1}{4}$  inch (6.35 mm). In walls constructed of wood or other combustible material, cabinets shall be flush with the finished surface or project therefrom.

**373-4. Unused Openings.** Unused openings in cabinet or cutout boxes shall be effectively closed to afford protection substantially equivalent to that of the wall of the cabinet or cutout box. Where metal plugs or plates are used with nonmetallic cabinets or cutout boxes, they shall be recessed at least  $\frac{1}{4}$  inch (6.35 mm) from the outer surface.

**373-5. Conductors Entering Cabinets or Cutout Boxes.** Conductors entering cabinets or cutout boxes shall be protected from abrasion and shall comply with (a) through (c) below.

(a) **Openings to Be Closed.** Openings through which conductors enter shall be adequately closed.

(b) **Metal Cabinets and Cutout Boxes.** Where metal cabinets or cutout boxes are installed with open wiring or concealed knob-and-tube wiring, conductors shall enter through insulating bushings or, in dry places, through flexible tubing extending from the last insulating support and firmly secured to the cabinet or cutout box.

(c) **Cables.** Where cable is used, each cable shall be secured to the cabinet or cutout box.

**373-6. Deflection of Conductors.** Conductors at terminals or conductors entering or leaving cabinets or cutout boxes and the like shall comply with (a) through (c) below.

(a) **Width of Wiring Gutters.** Conductors shall not be deflected within a cabinet or cutout box unless a gutter having a width in accordance with Table 373-6(a) is provided. Conductors in parallel in accordance with Section 310-4 shall be judged on the basis of the number of conductors in parallel.

**Table 373-6(a). Minimum Wire Bending Space at Terminals and Minimum Width of Wiring Gutters in Inches**

AWG or Circular-Mil Size of Wire	Wires per Terminal				
	1	2	3	4	5
14-10	Not Specified	—	—	—	—
8-6	1½	—	—	—	—
4-3	2	—	—	—	—
2	2½	—	—	—	—
1	3	—	—	—	—
0-00	3½	5	7	—	—
000-0000	4	6	8	—	—
250 MCM	4½	6	8	10	—
300-350 MCM	5	8	10	12	—
400-500 MCM	6	8	10	12	14
600-700 MCM	8	10	12	14	16
750-900 MCM	8	12	14	16	18
1000-1250 MCM	10	—	—	—	—
1500-2000 MCM	12	—	—	—	—

For SI units: one inch = 25.4 millimeters.

Bending space at terminals shall be measured in a straight line from the end of the lug or wire connector (in the direction that the wire leaves the terminal) to the wall, barrier, or obstruction.

(b) **Wire Bending Space at Terminals.** Wire bending space at each terminal shall be provided in accordance with (1) or (2) below:

(1) Table 373-6(a) shall apply where the conductor does not enter or leave the enclosure through the wall opposite its terminal.

*Exception No. 1: A conductor shall be permitted to enter or leave an enclosure through the wall opposite its terminal provided the conductor enters or leaves the enclosure where the gutter joins an adjacent gutter that has a width that conforms to Table 373-6(b) for that conductor.*

*Exception No. 2: A conductor not larger than 350 MCM shall be permitted to enter or leave an enclosure containing only a meter socket(s) through the wall opposite its terminal provided the terminal is a lay-in type where either:*

*a. the terminal is directly facing the enclosure wall and offset is not greater than 50 percent of the bending space specified in Table 373-6(a), or*

*b. the terminal is directed toward the opening in the enclosure and is within a 45-degree angle of directly facing the enclosure wall.*

(FPN): Offset is the distance measured along the enclosure wall from the axis of the centerline of the terminal to a line passing through the center of the opening in the enclosure.

(2) Table 373-6(b) shall apply where the conductor enters or leaves the enclosure through the wall opposite its terminal.

**Table 373-6(b). Minimum Wire Bending Space at Terminals for Section 373-6(b)(2) in Inches**

Wire Size	Wires per Terminal			
	1	2	3	4 or More
14-10	Not Specified	—	—	—
8	1½	—	—	—
6	2	—	—	—
4	3	—	—	—
3	3	—	—	—
2	3½	—	—	—
1	4½	—	—	—
0	5½	5½	7	—
2/0	6	6	7½	—
3/0	6½ (½)	6½ (½)	8	—
4/0	7 (1)	7½ (1½)	8½ (½)	—
250	8½ (2)	8½ (2)	9 (1)	10
300	10 (3)	10 (2)	11 (1)	12
350	12 (3)	12 (3)	13 (3)	14 (2)
400	13 (3)	13 (3)	14 (3)	15 (3)
500	14 (3)	14 (3)	15 (3)	16 (3)
600	15 (3)	16 (3)	18 (3)	19 (3)
700	16 (3)	18 (3)	20 (3)	22 (3)
750	17 (3)	19 (3)	22 (3)	24 (3)
800	18	20	22	24
900	19	22	24	24
1000	20	—	—	—
1250	22	—	—	—
1500	24	—	—	—
1750	24	—	—	—
2000	24	—	—	—

For SI units: one inch = 25.4 millimeters.

Bending space at terminals shall be measured in a straight line from the end of the lug or wire connector in a direction perpendicular to the enclosure wall.

For removable and lay-in wire terminals intended for only one wire, bending space shall be permitted to be reduced by the number of inches shown in parentheses.

(c) **Insulated Fittings.** Where ungrounded conductors of No. 4 or larger enter a raceway in a cabinet, pull box, junction box, or auxiliary gutter, the conductors shall be protected by a substantial fitting providing a smoothly rounded insulating surface, unless the conductors are separated from the raceway fitting by substantial insulating material securely fastened in place.

*Exception: Where threaded hubs or bosses that are an integral part of an enclosure provide a smoothly rounded or flared entry for conductors.*

Conduit bushings constructed wholly of insulating material shall not be used to secure a raceway. The insulating fitting or insulating material shall have a temperature rating not less than the insulation temperature rating of the installed conductors.

**373-7. Space in Enclosures.** Cabinets and cutout boxes shall have sufficient space to accommodate all conductors installed in them without crowding.

**373-8. Enclosures for Switches or Overcurrent Devices.** Enclosures for switches or overcurrent devices shall not be used as junction boxes, auxiliary gutters, or raceways for conductors feeding through or tapping off to other switches or overcurrent devices.

*Exception: Where adequate space is provided so that the conductors do not fill the wiring space at any cross section to more than 40 percent of the cross-sectional area of the space; and so that the conductors, splices, and taps do not fill the wiring space at any cross section to more than 75 percent of the cross-sectional area of the space.*

**373-9. Side or Back Wiring Spaces or Gutters.** Cabinets and cutout boxes shall be provided with back wiring spaces, gutters, or wiring compartments as required by Section 373-11(c) and (d).

## B. Construction Specifications

**373-10. Material.** Cabinets and cutout boxes shall comply with (a) through (c) below.

**(a) Metal Cabinets and Cutout Boxes.** Metal cabinets and cutout boxes shall be protected both inside and outside against corrosion.

(FPN): For protection against corrosion, see Section 300-6.

**(b) Strength.** The design and construction of cabinets and cutout boxes shall be such as to secure ample strength and rigidity. If constructed of sheet steel, the metal shall not be less than 0.053 inch (1.35 mm) uncoated.

**(c) Nonmetallic Cabinets.** Nonmetallic cabinets shall be submitted for approval prior to installation.

**373-11. Spacing.** The spacing within cabinets and cutout boxes shall comply with (a) through (d) below.

**(a) General.** Spacing within cabinets and cutout boxes shall be sufficient to provide ample room for the distribution of wires and cables placed in them, and for a separation between metal parts of devices and apparatus mounted within them as follows:

**(1) Base.** Other than at points of support, there shall be an air space of at least  $\frac{1}{16}$  inch (1.59 mm) between the base of the device and the wall of any metal cabinet or cutout box in which the device is mounted.

**(2) Doors.** There shall be an air space of at least  $\frac{1}{8}$  inch (25.4 mm) between any live metal part, including live metal parts of enclosed fuses, and the door.



*Exception: Where the door is lined with an approved insulating material or is of a thickness of metal not less than No. 12 MSG, the air space shall not be less than 1/2 inch (12.7 mm).*

**(3) Live Parts.** There shall be an air space of at least 1/2 inch (12.7 mm) between the walls, back, gutter partition, if of metal, or door of any cabinet or cutout box and the nearest exposed current-carrying part of devices mounted within the cabinet where the voltage does not exceed 250. This spacing shall be increased to at least 1 inch (25.4 mm) for voltages 251 to 600, nominal.

*Exception: As permitted in (2) above.*

**(b) Switch Clearance.** Cabinets and cutout boxes shall be deep enough to allow the closing of the doors when 30-ampere branch-circuit panelboard switches are in any position; when combination cutout switches are in any position; or when other single-throw switches are opened as far as their construction will permit.

**(c) Wiring Space.** Cabinets and cutout boxes that contain devices or apparatus connected within the cabinet or box to more than eight conductors, including those of branch circuits, meter loops, subfeeder circuits, power circuits, and similar circuits, but not including the supply circuit or a continuation thereof, shall have back-wiring spaces or one or more side-wiring spaces, side gutters, or wiring compartments.

**(d) Wiring Space — Enclosure.** Side-wiring spaces, side gutters, or side-wiring compartments of cabinets and cutout boxes shall be made tight enclosures by means of covers, barriers, or partitions extending from the bases of the devices, contained in the cabinet to the door, frame, or sides of the cabinet.

*Exception: Where the enclosure contains only those conductors that are led from the cabinet at points directly opposite their terminal connections to devices within the cabinet.*

Partially enclosed back-wiring spaces shall be provided with covers to complete the enclosure. Wiring spaces that are required by (c) above, and that are exposed when doors are open, shall be provided with covers to complete the enclosure. Where adequate space is provided for feed-through conductors and for splices as required in Section 373-8, Exception, additional barriers shall not be required.

## ARTICLE 374 — AUXILIARY GUTTERS

**374-1. Use.** Auxiliary gutters shall be permitted to supplement wiring spaces at meter centers, distribution centers, switchboards, and similar points of wiring systems and may enclose conductors or busbars, but shall not be used to enclose switches, overcurrent devices, appliances, or other similar equipment.

**374-2. Extension Beyond Equipment:** An auxiliary gutter shall not extend a greater distance than 30 feet (9.14 m) beyond the equipment which it supplements.

*Exception: As provided in Section 620-35 for elevators.*

(FPN): For wireways, see Article 362. For busways, see Article 364.

**374-3. Supports.** Gutters shall be supported throughout their entire length at intervals not exceeding 5 feet (1.52 m).

**374-4. Covers.** Covers shall be securely fastened to the gutter.

**374-5. Number of Conductors.** Auxiliary gutters shall not contain more than thirty current-carrying conductors at any cross section. The sum of the cross-sectional areas of all contained conductors at any cross section of an auxiliary gutter shall not exceed 20 percent of the interior cross-sectional area of the auxiliary gutter.

*Exception No. 1: As provided in Section 620-35 for elevators.*

*Exception No. 2: Conductors for signaling circuits or controller conductors between a motor and its starter and used only for starting duty shall not be considered as current-carrying conductors.*

*Exception No. 3: Where the correction factors specified in Note 8 (a) to Tables 310-16 through 310-31 are applied, there shall be no limit on the number of current-carrying conductors, but the sum of the cross-sectional area of all contained conductors at any cross section of the auxiliary gutter shall not exceed 20 percent of the interior cross-sectional area of the auxiliary gutter.*

(FPN): For conductor cross-sectional area see Tables 5, 5A, 6, 7, 8 and the applicable Notes to Tables at the beginning of Chapter 9.

**374-6. Ampacity of Conductors.** Where the number of current-carrying conductors contained in the auxiliary gutter is thirty or less, the correction factors specified in Note 8 (a) to Tables 310-16 through 310-31 shall not apply. The current carried continuously in bare copper bars in auxiliary gutters shall not exceed 1000 amperes per square inch (645 sq mm) of cross section of the conductor. For aluminum bars, the current carried continuously shall not exceed 700 amperes per square inch (645 sq mm) of cross section of the conductor.

**374-7. Clearance of Bare Live Parts.** Bare conductors shall be securely and rigidly supported so that the minimum clearance between bare current-carrying metal parts of opposite polarities mounted on the same surface will not be less than 2 inches (50.8 mm), nor less than 1 inch (25.4 mm) for parts that are held free in the air. A clearance not less than 1 inch (25.4 mm) shall be secured between bare current-carrying metal parts and any metal surface. Adequate provisions shall be made for the expansion and contraction of busbars.

**374-8. Splices and Taps.** Splices and taps shall comply with (a) through (d) below.

**(a) Within Gutters:** Splices or taps shall be permitted within gutters when they are accessible by means of removable covers or doors. The conductors, including splices and taps, shall not fill the gutter to more than 75 percent of its area.

**(b) Bare Conductors:** Taps from bare conductors shall leave the gutter opposite their terminal connections and conductors shall not be brought in contact with uninsulated current-carrying parts of opposite polarity.

(c) **Suitably Identified.** All taps shall be suitably identified at the gutter-as to the circuit or equipment which they supply.

(d) **Overcurrent Protection.** Tap connections from conductors in auxiliary gutters shall be provided with overcurrent protection as required in Section 240-21.

**374-9. Construction and Installation.** Auxiliary gutters shall comply with (a) through (e) below.

(a) **Electrical and Mechanical Continuity.** Gutters shall be so constructed and installed that adequate electrical and mechanical continuity of the complete system will be secured.

(b) **Substantial Construction.** Gutters shall be of substantial construction and shall provide a complete enclosure for the contained conductors. All surfaces, both interior and exterior, shall be suitably protected from corrosion. Corner joints shall be made tight and, where the assembly is held together by rivets or bolts shall be spaced not more than 12 inches (305 mm) apart.

(c) **Smooth Rounded Edges.** Suitable bushings, shields, or fittings having smooth rounded edges shall be provided where conductors pass between gutters, through partitions, around bends, between gutters and cabinets or junction boxes, and at other locations where necessary to prevent abrasion of the insulation of the conductors.

(d) **Deflected Insulated Conductors.** Where insulated conductors are deflected within an auxiliary gutter, either at the ends or where conduits, fittings, or other raceways or cables enter or leave the gutter, or where the direction of the gutter is deflected greater than 30 degrees, dimensions corresponding to Section 373-6 shall apply.

(e) **Outdoor Use.** Auxiliary gutters installed in wet locations shall be of raintight construction.

## ARTICLE 380 — SWITCHES

### A. Installation

**380-1. Scope.** The provisions of this article shall apply to all switches, switching devices, and circuit breakers where used as switches.

**380-2. Switch Connections.**

(a) **Three-Way and Four-Way Switches.** Three-way and four-way switches shall be so wired that all switching is done only in the ungrounded circuit conductor. Where in metal raceways, wiring between switches and outlets shall be in accordance with Section 300-20(a).

*Exception: Switch loops shall not require a grounded conductor.*

(b) **Grounded Conductors.** Switches or circuit breakers shall not disconnect the grounded conductor of a circuit.

*Exception No. 1: Where the switch or circuit breaker simultaneously disconnects all conductors of the circuit.*

*Exception No. 2: Where the switch or circuit breaker is so arranged that the grounded conductor cannot be disconnected until all the ungrounded conductors of the circuit have been disconnected.*

**380-3. Enclosure.** Switches and circuit breakers shall be of the externally operable type mounted in an enclosure listed for the intended use. The minimum wire bending space at terminals and minimum gutter space provided in switch enclosures shall be as required in Section 373-6.

*Exception: Pendant- and surface-type snap switches and knife switches mounted on an open-face switchboard or panelboard.*

**380-4. Wet Locations.** A switch or circuit breaker in a wet location or outside of a building shall be enclosed in a weatherproof enclosure or cabinet that shall comply with Section 373-2(a).

**380-5. Time Switches, Flashers, and Similar Devices.** Time switches, flashers, and similar devices need not be of the externally operable type. They shall be enclosed in metal boxes or cabinets.

*Exception No. 1: Where mounted in switchboards, control panels, or enclosures and so located that any live terminals, located within 6 inches (152 mm) of the manually adjustable clock dial or "on-off" switch, are covered by suitable barriers.*

*Exception No. 2: Where enclosed in approved individual housings with no live parts exposed to the operator.*

**380-6. Position of Knife Switches.**

(a) **Single-Throw Knife Switches.** Single-throw knife switches shall be so placed that gravity will not tend to close them. Single-throw knife switches, approved for use in the inverted position, shall be provided with a locking device that will ensure that the blades remain in the open position when so set.

(b) **Double-Throw Knife Switches.** Double-throw knife switches shall be permitted to be mounted so that the throw will be either vertical or horizontal. Where the throw is vertical, a locking device shall be provided to hold the blades in the open position when so set.

(c) **Connection of Knife Switches.** Single-throw knife switches shall be so connected that the blades are deenergized when the switch is in the open position.

*Exception: Where the load side of the switch is connected to circuits or equipment, the inherent nature of which may provide a backfeed source of power. For such installations, a permanent sign shall be installed on the switch enclosure or immediately adjacent to open switches reading: "WARNING—LOAD SIDE OF SWITCH MAY BE ENERGIZED BY BACKFEED."*

**380-7. Indicating.** General-use and motor-circuit switches and circuit breakers, where mounted in an enclosure as described in Section 380-3, shall clearly indicate whether they are in the open "off" or closed "on" position.

Where these switch or circuit breaker handles are operated vertically rather than rotationally or horizontally, the up position of the handle shall be the "on" position.

*Exception: Double-throw switches.*

**380-8. Accessibility and Grouping.**

(a) **Location.** All switches and circuit breakers used as switches shall be so located that they may be operated from a readily accessible place. They shall be so installed that the center of the grip of the operating handle of the switch or circuit breaker, when in its highest position, will not be more than 6½ feet (1.98 m) above the floor or working platform.

*Exception No. 1: On busway installations, fused switches and circuit breakers shall be permitted to be located at the same level as the busway. Suitable means shall be provided to operate the handle of the device from the floor.*

*Exception No. 2: Switches installed adjacent to motors, appliances, or other equipment which they supply shall be permitted to be located higher than specified in the foregoing and to be accessible by portable means.*

*Exception No. 3: Hookstick operable isolating switches shall be permitted at heights of more than 6½ feet (1.98 m).*

(b) **Voltage Between Adjacent Switches.** Snap switches shall not be grouped or ganged in outlet boxes unless they can be so arranged that the voltage between adjacent switches does not exceed 300, or unless they are installed in boxes equipped with permanently installed barriers between adjacent switches.

**380-9. Faceplates for Flush-Mounted Snap Switches.** Flush snap switches, that are mounted in ungrounded metal boxes and located within reach of conducting floors or other conducting surfaces, shall be provided with faceplates of nonconducting, noncombustible material. Metal faceplates shall be of ferrous metal not less than 0.030 inch (0.762 mm) in thickness or of nonferrous metal not less than 0.040 inch (1.016 mm) in thickness. Faceplates of insulating material shall be noncombustible and not less than 0.10 inch (2.54 mm) in thickness but they shall be permitted to be less than 0.10 inch (2.54 mm) in thickness if formed or reinforced to provide adequate mechanical strength. Faceplates shall be installed so as to completely cover the wall opening and seat against the wall surface.

**380-10. Mounting of Snap Switches.**

(a) **Surface-type.** Snap switches used with open wiring on insulators shall be mounted on insulating material that will separate the conductors at least ½ inch (12.7 mm) from the surface wired over.

(b) **Box Mounted.** Flush-type snap switches mounted in boxes that are set back of the wall surface as permitted in Section 370-10 shall be installed so that the extension plaster ears are seated against the surface of the wall. Flush-type snap switches mounted in boxes that are flush with the wall surface or project therefrom shall be so installed that the mounting yoke or strap of the switch is seated against the box.

**380-11. Circuit Breakers as Switches.** A hand-operable circuit breaker equipped with a lever or handle, or a power-operated circuit breaker capable of being opened by hand in the event of a power failure, shall be permitted to serve as a switch if it has the required number of poles. Note: See provisions contained in Section 240-81.

**380-12. Grounding of Enclosures.** Enclosures for switches or circuit breakers shall be grounded as specified in Article 250. Where nonmetallic

enclosures are used with metal-sheathed cables or metallic conduits, provision shall be made for grounding continuity.

### 380-13. Knife Switches.

(a) **Isolating Switches.** Knife switches rated at over 1200 amperes at 250 volts or less, and at over 600 amperes at 251 to 600 volts, shall be used only as isolating switches and shall not be opened under load.

(b) **To Interrupt Currents.** To interrupt currents over 1200 amperes at 250 volts, nominal, or less, or over 600 amperes at 251 to 600 volts, nominal, a circuit breaker or a switch of special design listed for such purpose shall be used.

(c) **General-Use Switches.** Knife switches of ratings less than specified in (a) and (b) above shall be considered general-use switches.

(FPN): See definition of general-use switch in Article 100.

(d) **Motor-Circuit Switches.** Motor-circuit switches shall be permitted to be of the knife-switch type.

(FPN): See definition of a motor-circuit switch in Article 100.

**380-14. Rating and Use of Snap Switches.** Snap switches shall be used within their ratings and as indicated in (a) through (c) below:

(a) **AC General-Use Snap Switch.** A form of general-use snap switch suitable only for use on alternating-current circuits for controlling the following:

(1) Resistive and inductive loads, including electric-discharge lamps, not exceeding the ampere rating of the switch at the voltage involved.

(2) Tungsten-filament lamp loads not exceeding the ampere rating of the switch at 120 volts.

(3) Motor loads not exceeding 80 percent of the ampere rating of the switch at its rated voltage.

(b) **AC-DC General-Use Snap Switch.** A form of general-use snap switch suitable for use on either ac or dc circuits for controlling the following:

(1) Resistive loads not exceeding the ampere rating of the switch at the voltage applied.

(2) Inductive loads not exceeding 50 percent of the ampere rating of the switch at the applied voltage. Switches rated in horsepower are suitable for controlling motor loads within their rating at voltage applied.

(3) Tungsten-filament lamp loads not exceeding the ampere rating of the switch at the applied voltage if "T" rated.

(FPN): For switches on signs and outline lighting, see Section 600-2.

(FPN): For switches controlling motors, see Sections 430-83, 430-109, and 430-110.

(c) **CO/ALR Snap Switches.** Snap switches rated 20 amperes or less directly connected to aluminum conductors shall be listed and marked CO/ALR.

## B. Construction Specifications

**380-15. Marking.** Switches shall be marked with the current and voltage and, if horsepower rated, the maximum rating for which they are designed.

**380-16. 600-Volt Knife Switches.** Auxiliary contacts of a renewable or quick-break type or the equivalent shall be provided on all knife switches rated 600 volts designed for use in breaking current over 200 amperes.

**380-17. Fused Switches:** A fused switch shall not have fuses in parallel.  
(FPN): See Section 240-8, Exception.

**380-18. Wire Bending Space.** The wire bending space required by Section 380-3 shall meet Table 373-6(b) spacings to the enclosure wall opposite the line and load terminals.

## ARTICLE 384 — SWITCHBOARDS AND PANELBOARDS

**384-1. Scope.** This article covers (1) all switchboards, panelboards, and distribution boards installed for the control of light and power circuits, and (2) battery-charging panels supplied from light or power circuits.

*Exception: Switchboards or portions thereof used exclusively to control signaling circuits operated by batteries.*

**384-2. Other Articles.** Switches, circuit breakers, and overcurrent devices used on switchboards, panelboards, and distribution boards, and their enclosures, shall comply with this article and also with the requirements of Articles 240, 250, 370, 380, and other articles that apply. Switchboards and panelboards in hazardous (classified) locations shall comply with the requirements of Articles 500 through 517.

**384-3. Support and Arrangement of Busbars and Conductors.**

**(a) Conductors and Busbars on a Switchboard, Panelboard, or Control Board.** Conductors and busbars on a switchboard, panelboard, or control board shall be so located as to be free from physical damage and shall be held firmly in place. Other than the required interconnections and control wiring, only those conductors that are intended for termination in a vertical section of a switchboard shall be located in that section. Barriers shall be placed in all service switchboards that will isolate the service busbars and terminals from the remainder of the switchboard.

*Exception: Conductors shall be permitted to travel horizontally through vertical sections of switchboards where such conductors are isolated from busbars by a barrier.*

**(b) Overheating and Inductive Effects.** The arrangement of busbars and conductors shall be such as to avoid overheating due to inductive effects.

**(c) Used as Service Equipment.** Each switchboard, switchboard section, or panelboard, if used as service equipment, shall be provided with a main bonding jumper sized in accordance with Section 250-79(c) or the equivalent placed within the service disconnect section for connecting the grounded service conductor on its supply side to the switchboard or panelboard frame. All sections of a switchboard shall be bonded together using an equipment grounding conductor sized in accordance with Table 250-95.

(d) **Load Terminals.** Load terminals in switchboards and panelboards shall be so located that it will be unnecessary to reach across or beyond an ungrounded line bus in order to make load connections.

(e) **High-Leg Marking.** On a switchboard or panelboard supplied from a 4-wire delta-connected system, where the midpoint of one phase is grounded, that phase busbar or conductor having the higher voltage to ground shall be durably and permanently marked by an outer finish that is orange in color, or by other effective means.

(f) **Phase Arrangement.** The phase arrangement on three-phase buses shall be A, B, C from front to back, top to bottom, or left to right, as viewed from the front of the switchboard or panelboard. The B phase shall be that phase having the higher voltage to ground on 3-phase, 4-wire delta-connected systems. Other busbar arrangements shall be permitted for additions to existing installations and shall be marked.

*Exception: Equipment within the same single section or multisection switchboard or panelboard as the meter on 3-phase, 4-wire delta-connected systems shall be permitted to have the same phase configuration as the metering equipment.*

(g) **Minimum Wire Bending Space.** The minimum wire bending space at terminals and minimum gutter space provided in panelboards and switchboards shall be as required in Section 373-6.

**384-4. Installation.** Equipment within the scope of Article 384 shall be located in rooms or spaces dedicated to such equipment. Such space shall include that space described in Section 110-16, and in addition shall include an exclusively dedicated space extending from floor to structural ceiling with a width and depth that of the equipment. No piping, ducts, or equipment foreign to the electrical equipment or architectural appurtenances shall be permitted to be installed in, enter or pass through such spaces or rooms.

(FPN): It is not the intent to mandate a dedicated room.

(FPN): This section is not intended to prohibit sprinkler protection for the electrical installation.

*Exception No. 1: Control equipment which by its very nature or because of other rules of this Code must be adjacent to or within sight of its operating machinery.*

*Exception No. 2: Ventilating, heating, or cooling equipment that serves the electrical rooms or spaces.*

*Exception No. 3: Equipment located throughout industrial plants which is isolated from foreign equipment by height or physical enclosures or covers which will afford adequate mechanical protection from vehicular traffic, accidental contact by unauthorized personnel, or accidental spillage or leakage from piping systems.*

*Exception No. 4: Outdoor electrical equipment located in weatherproof enclosures protected from accidental contact by unauthorized personnel or vehicular traffic or accidental spillage or leakage from piping systems.*

## A. Switchboards

**384-5. Location of Switchboards.** Switchboards that have any exposed live parts shall be located in permanently dry locations and then only where under



competent supervision and accessible only to qualified persons. Switchboards shall be so located that the probability of damage from equipment or processes is reduced to a minimum.

**384-6. Wet Locations.** Where a switchboard is in a wet location or outside of a building, it shall be enclosed in a weatherproof enclosure or cabinet installed to comply with Section 373-2(a).

**384-7. Location Relative to Easily Ignitable Material.** Switchboards shall be so placed as to reduce to a minimum the probability of communicating fire to adjacent combustible materials. Where installed over a combustible floor, suitable protection thereto shall be provided.

**384-8. Clearances.**

**(a) From Ceiling.** A space of 3 feet (914 mm) or more shall be provided between the top of any switchboard and any combustible ceiling.

*Exception No. 1: Where a noncombustible shield is provided between the switchboard and the ceiling.*

*Exception No. 2: Totally enclosed switchboards.*

**(b) Around Switchboards.** Clearances around switchboards shall comply with the provisions of Section 110-16.

**384-9. Conductor Insulation.** An insulated conductor used within a switchboard shall be listed, flame-retardant and shall be rated not less than the voltage applied to it and not less than the voltage applied to other conductors or busbars with which it may come in contact.

**384-10. Clearance for Conductors Entering Bus Enclosures.** Where conduits or other raceways enter a switchboard, floor standing panelboard, or similar enclosure at the bottom, sufficient space shall be provided to permit installation of conductors in the enclosure. The wiring space shall not be less than shown in the following table where the conduit or raceways enter or leave the enclosure below the busbars, their supports, or other obstructions. The conduit or raceways, including their end fittings, shall not rise more than 3 inches (76 mm) above the bottom of the enclosure.

**Minimum Spacing Between  
Bottom of Enclosure and  
Busbars, their Supports, or other  
Obstructions (Inches)**

**Conductor**

Insulated busbars, their supports, or other obstructions	8 (203mm)
Noninsulated busbars	10 (254mm)

**384-11. Grounding Switchboard Frames.** Switchboard frames and structures supporting switching equipment shall be grounded.

*Exception: Frames of direct-current, single-polarity switchboards shall not be required to be grounded if effectively insulated.*

**384-12. Grounding of Instruments, Relays, Meters, and Instrument Transformers on Switchboards.** Instruments, relays, meters, and instrument

transformers located on switchboards shall be grounded as specified in Sections 250-121 through 250-125.

## B. Panelboards

**384-13. General.** All panelboards shall have a rating not less than the minimum feeder capacity required for the load computed in accordance with Article 220. Panelboards shall be durably marked by the manufacturer with the voltage and the current rating and the number of phases for which they are designed and with the manufacturer's name or trademark in such a manner as to be visible after installation, without disturbing the interior parts or wiring.

**384-14. Lighting and Appliance Branch-Circuit Panelboard.** For the purposes of this article, a lighting and appliance branch-circuit panelboard is one having more than 10 percent of its overcurrent devices rated 30 amperes or less, for which neutral connections are provided.

**384-15. Number of Overcurrent Devices on One Panelboard.** Not more than forty-two overcurrent devices (other than those provided for in the mains) of a lighting and appliance branch-circuit panelboard shall be installed in any one cabinet or cutout box.

A lighting and appliance branch-circuit panelboard shall be provided with physical means to prevent the installation of more overcurrent devices than that number for which the panelboard was designed, rated, and approved.

For the purposes of this article, a 2-pole circuit breaker shall be considered two overcurrent devices; a 3-pole breaker shall be considered three overcurrent devices.

### 384-16. Overcurrent Protection.

**(a) Lighting and Appliance Branch-Circuit Panelboard Individually Protected.** Each lighting and appliance branch-circuit panelboard shall be individually protected on the supply side by not more than two main circuit breakers or two sets of fuses having a combined rating not greater than that of the panelboard.

*Exception No. 1: Individual protection for a lighting and appliance panelboard shall not be required if the panelboard feeder has overcurrent protection not greater than the rating of the panelboard.*

*Exception No. 2: For existing installations, individual protection for lighting and appliance branch-circuit panelboards is not required where such panelboards are used as service equipment in supplying an individual residential occupancy.*

**(b) Snap Switches Rated at 30 Amperes or Less:** Panelboards equipped with snap switches rated at 30 amperes or less shall have overcurrent protection not in excess of 200 amperes.

**(c) Continuous Load.** The total load on any overcurrent device located in a panelboard shall not exceed 80 percent of its rating where in normal operation the load will continue for 3 hours or more.

*Exception: Where the assembly including the overcurrent device is approved for continuous duty at 100 percent of its rating.*

**(d) Supplied through a Transformer.** Where a panelboard is supplied through a transformer, the overcurrent protection required in (a) and (b) above shall be located on the secondary side of the transformer.

*Exception: A panelboard supplied by the secondary side of a single-phase transformer having a two-wire (single-voltage) secondary shall be considered as protected by overcurrent protection provided on the primary (supply) side of the transformer, provided this protection is in accordance with Section 450-3(b)(1) and does not exceed the value determined by multiplying the panelboard rating by the secondary-to-primary voltage ratio.*

**(e) Delta Breakers.** A three-phase disconnect or overcurrent device shall not be connected to the bus of any panelboard that has less than three-phase buses.

(FPN): This is intended to prohibit the use of "delta breakers" in panelboards.

**384-17. Panelboards in Damp or Wet Locations.** Panelboards in damp or wet locations shall be installed to comply with Section 373-2(a).

**384-18. Enclosure.** Panelboards shall be mounted in cabinets, cutout boxes, or enclosures designed for the purpose and shall be dead front.

*Exception: Panelboards other than of the dead front externally operable type shall be permitted where accessible only to qualified persons.*

**384-19. Relative Arrangement of Switches and Fuses.** In panelboards, fuses of any type shall be installed on the load side of any switches.

*Exception: As provided in Section 230-94 for use as service equipment.*

### C. Construction Specifications

**384-20. Panels.** The panels of switchboards shall be made of moisture-resistant, noncombustible material.

**384-21. Busbars.** Insulated or bare busbars shall be rigidly mounted.

**384-22. Protection of Instrument Circuits.** Instruments, pilot lights, potential transformers, and other switchboard devices with potential coils shall be supplied by a circuit that is protected by standard overcurrent devices rated 15 amperes or less.

*Exception No. 1: Where the operation of the overcurrent device might introduce a hazard in the operation of devices.*

*Exception No. 2: For ratings of 2 amperes or less, special types of enclosed fuses shall be permitted.*

**384-23. Component Parts.** Switches, fuses, and fuseholders used on panelboards shall comply with the applicable requirements of Articles 240 and 380.

**384-24. Knife Switches.** Exposed blades of knife switches shall be deenergized when open.

**384-25. Wire Bending Space in Panelboards.** The enclosure for a panelboard shall have the top and bottom wire bending space sized in accordance with Table 373-6(b) for the largest conductor entering or leaving

the enclosure. Side wire bending space shall be in accordance with Table 373-6(a) for the largest conductor to be terminated in that space.

*Exception No. 1: Either the top or bottom wire bending space shall be permitted to be sized in accordance with Table 373-6(a) for a lighting and appliance branch-circuit panelboard rated 225 amperes or less.*

*Exception No. 2: Either the top or bottom wire bending space for any panelboard shall be permitted to be sized in accordance with Table 373-6(a) where at least one side wire bending space is sized in accordance with Table 373-6(b) for the largest conductor to be terminated in any side wire bending space.*

*Exception No. 3: The top and bottom wire bending space shall be permitted to be sized in accordance with Table 373-6(a) spacings if the panelboard is designed and constructed for wiring using only one single 90 degree bend for each conductor including the neutral and the wiring diagram shows and specifies the method of wiring that shall be used.*

*Exception No. 4: Either the top or the bottom wire bending space, but not both, shall be permitted to be sized in accordance with Table 373-6(a) where there are no conductors terminated in that space.*

**384-26. Minimum Spacings.** The distance between bare metal parts, busbars, etc., shall not be less than specified in Table 384-26.

*Exception No. 1: At switches or circuit breakers.*

*Exception No. 2: Inherent spacings in listed components.*

Where close proximity does not cause excessive heating, parts of the same polarity at switches, enclosed fuses, etc., shall be permitted to be placed as close together as convenience in handling will allow.

**Table 384-26. Minimum Spacings Between Bare Metal Parts**

	Opposite Polarity Where Mounted on the Same Surface	Opposite Polarity Where Held Free in Air	*Live Parts to Ground
Not over 125 volts, nominal	¾ inch	½ inch	½ inch
Not over 250 volts, nominal	1¼ inch	¾ inch	½ inch
Not over 600 volts, nominal	2 inches	1 inch	1 inch

For SI units: one inch = 25.4 millimeters.

\* For spacing between live parts and doors of cabinets, see Section 373-11(a) (1); (2), and (3).

**384-27. Grounding of Panelboards.** Panelboard cabinets shall be grounded in the manner specified in Article 250 or Section 384-3(c). An approved terminal bar for equipment grounding conductors shall be provided and secured inside of the cabinet for the attachment of all the feeder and branch-circuit equipment grounding conductors, where the panelboard is used with nonmetallic raceway or cable, or where separate grounding conductors are provided. The terminal bar shall be bonded to the cabinet or panelboard frame, or at the first system disconnecting means or overcurrent device for a

separately derived system, and shall not be connected to the neutral bar in other than service equipment.

*Exception No. 1: Where an isolated equipment grounding conductor is provided as permitted by Section 250-74, Exception No. 4, this insulated equipment grounding conductor which is run with the circuit conductors shall be permitted to pass through the panelboard without being connected to the panelboard's equipment grounding terminal bar.*

*Exception No. 2: The terminal bar for equipment grounding conductors shall be permitted to be connected to the neutral bar at separate buildings in accordance with the provisions of Section 250-24.*

## Chapter 4. Equipment for General Use

### ARTICLE 400 — FLEXIBLE CORDS AND CABLES

#### A. General

**400-1. Scope.** This article covers general requirements, applications, and construction specifications for flexible cords and flexible cables.

**400-2. Other Articles.** Flexible cords and flexible cables shall comply with this article and with the applicable provisions of other articles of this Code.

**400-3. Suitability.** Flexible cords and cables and their associated fittings shall be suitable for the conditions of use and location.

**400-4. Types.** Flexible cords and flexible cables shall conform to the description in Table 400-4. Types of flexible cords and flexible cables other than those listed in the table shall be the subject of special investigation.

#### Notes to Table 400-4

1. Except for Types SP-1, SPE-1, SP-2, SPE-2, AFPO, SP-3, SPE-3, SPT-1, SPT-2, SPT-3, HPN, TPT, and 3-conductor parallel versions of SRD, SRDE, SRDT, individual conductors are twisted together.

2. Cables constructed differently than specified herein and listed as component parts of a data processing system shall be permitted.

3. Types TPT, TS, and TST shall be permitted in lengths not exceeding 8 feet (2.44 m) when attached directly, or by means of a special type of plug, to a portable appliance rated at 50 watts or less and of such nature that extreme flexibility of the cord is essential.

4. Rubber-filled or varnished cambric tapes shall be permitted as a substitute for the inner braids.

5. Types S, SO, SE, SEO, SOO, ST, STO, STOO, G, and W shall be permitted for use on theater stages, in garages, and elsewhere where flexible cords are permitted by this Code.

6. Elevator traveling cables for operating control and signal circuits shall contain nonmetallic fillers as necessary to maintain concentricity. Cables exceeding 100 feet (30.5 m) between supports shall have steel supporting members. In locations subject to excessive moisture or corrosive vapors or gases, supporting members of other materials shall be permitted. Where steel supporting members are used, they shall run straight through the center of the cable assembly and shall not be cabled with the copper strands of any conductor.

In addition to conductors used for control and signaling circuits, Types E, EO, EN, ET, ETP, ETLB and ETT elevator cables shall be permitted to incorporate in the construction one or more No. 20 AWG telephone conductor pairs and/or one or more coaxial cables. The No. 20 AWG conductor pairs shall be permitted to be covered with suitable shielding for

**Table 400-4. Flexible Cords and Cables**  
(See Section 400-4)

Trade Name	Type Letter	Size, AWG	No. of Conductors	Insulation	Nominal Insulation Thickness		Braid on Each Conductor	Outer Covering	Use		
					AWG	Mils					
Asbestos-Covered Heat-Resistant Cord	AFC	18-10	2 or 3	Impregnated Asbestos	18-14	30	Cotton or Rayon	None	Pendant	Dry Locations	Not Hard Usage
	AFPD		2					None			
Thermoset-Jacketed Heat-Resistant Cord	AFPO				12-10	45					
	AFS	18-10	2 or 3	Impregnated Asbestos	18-14	30	None	Thermoset	Portable Heaters	Damp Locations	Extra Hard Usage
AFSJ	18-16	Hard Usage									
Lamp Cord	C	18-10	2 or more	Thermoset or Thermoplastic	18-16	30	Cotton	None	Pendant or Portable	Dry Locations	Not Hard Usage
					14-10	45					
Data Processing Cable	DP See Note 2.	32 Min.	2 or More	Thermoplastic, Thermoset or Cross-linked Synthetic Polymer	32-27 ( 50V)	8	None	Thermoplastic, Thermoset or Crosslinked Synthetic Polymer	Data Processing Systems	Dry Locations	Power and Signaling Circuits
					26-23 ( 50V)	12					
					22-20 ( 50V)	16					
					32-16 (300V)	20					
					14-10 (300V)	30					
					8- 2 (300V)	60					

See Notes 1 through 9.  
\* See Note 9.

**Table 400-4 (Continued)**

Elevator Cable	E See Note 6.	20-14	2 or More	Thermoset	20-16	20	Cotton	Three Cotton, Outer one Flame- Retardant & Moisture-Resist. See Note 4.	Elevator Lighting and Control	Nonhazardous Locations
	EN See Note 6.				20-16	20	Flexible Nylon Jacket	One Cotton and a Neoprene or Thermoplastic Jacket See Note 4.		
Elevator Cable	EO See Note 6.	20-14	2 or More	Thermoset	20-16	20	Cotton	Three Cotton, Outer one Flame- Retardant & Moisture-Resist. See Note 4.	Elevator Lighting and Control	Nonhazardous Locations
					14	30		One Cotton and a Neoprene Jacket See Note 4.		
Elevator Cable	ET See Note 6.	20-14	2 or More	Thermo- plastic	20-16	20	Rayon	Three Cotton, Outer one Flame- Retardant & Moisture-Resist. See Note 4.		Nonhazardous Locations
	ETLB See Note 6.				14	30	None			
	ETP See Note 6.					Rayon	Thermoplastic			
	ETT See Note 6.					Thermo- plastic	None	One Cotton and a Thermo- plastic jacket		

See Notes 1 through 9.

\* See Note 9.



Table 400-4 (Continued)

Trade Name	Type Letter	Size AWG	No. of Conductors	Insulation	Nominal Insulation Thickness		Braid on Each Conductor	Outer Covering	Use		
					AWG	Mils					
Portable Power Cable	G	8-500 MCM	2-6 plus Grounding Conductor(s)	Thermoset	8-2 1-4/0 250 MCM- 500 MCM	60 80 95		Oil-Resistant Thermoset	Portable, Extra Hard Usage, and as Permitted in Sections 520-68 and 530-12.		
Heater Cord	HPD	18-12	2, 3, or 4	Thermoset with Asbestos or All Thermoset	Thermoset 18-16 14-12	15 30	None	Cotton or Rayon	Portable Heaters	Dry Locations	Not Hard Usage
Parallel Heater Cord	HPN See Note 7.	18-12	2 or 3	Thermosetting	18-16 14 12	45 80 95	None	Thermosetting	Portable	Damp Locations	Not Hard Usage
Thermoset Jacketed Heater Cord	HS	14-12	2, 3 or 4	Thermoset with Asbestos or All Thermoset	18-16 (Thermoset/Asbestos)	15	None	Cotton and Thermoset	Portable or Portable Heaters	Damp Locations	Extra Hard Usage
	HSJ See Note 8.	18-12			18-16 (All Thermoset)	30					
	HSJO See Note 8.	14-12			14-12 (Thermoset/Asbestos)	30					
	HSO				14-12 (All Thermoset)	45		Extra Hard Usage			
Twisted Portable Cord	PD	18-10	2 or more	Thermoset or Thermo-plastic	18-16 14-10	30 45	Cotton	Cotton or Rayon	Pendant or Portable	Dry Locations	Not Hard Usage

See Notes 1 through 9.

\* See Note 9.

**Table 400-4 (Continued)**

Hard Service Cord	S See Note 5.	18-2	2 or more	Thermoset	18-16	30	None	Thermoset	Pendant or Portable	Damp Locations	Extra Hard Usage		
	SE See Note 5.			Thermoplastic Elastomer	14-10	45		Thermoplastic Elastomer					
	SEO See Note 5.				8-2	60		Oil-Resistant Thermoplastic Elastomer					
Junior Hard Service Cord	SJ	18-10	2, 3, 4, or 5	Thermoset	18-12	30	None	Thermoset	Pendant or Portable	Damp Locations	Hard Usage		
	SJE			Thermoplastic Elastomer									Thermoplastic Elastomer
	SJEO												Oil-Resistant Thermoplastic Elastomer
	SJO			Thermoset									Oil-Resistant Thermoset
	SJOO			Oil-Resistant Thermoset									Oil-Resistant Thermoset
	SJT			Thermoplastic or Thermoset				10				45	Thermoplastic
	SJTO			Thermoset or Thermoplastic									Oil-Resistant Thermoplastic
	SJTOO			Oil-Resistant Thermoplastic or Thermoset									Oil-Resistant Thermoplastic

See Notes 1 through 9.

\* See Note 9.

Table 400-4 (Continued)

Trade Name	Type Letter	Size AWG	No. of Conductors	Insulation	Nominal Insulation Thickness		Braid on Each Conductor	Outer Covering	Use		
					AWG	Mils					
Hard Service Cord	SO See Note 5.	18-2	2 or more	Thermoset	18-16	30		Oil-Resistant Thermoset	Pendant or Portable	Damp Locations	Extra Hard Usage
	SOO See Note 5.			Oil-Resistant Thermoset	14-10	45		Oil-Resistant Thermoset			
					8-2	60					
All Thermoset Parallel Cord	SP-1 See Note 7.	18	2 or 3	Thermoset	18	30	None	Thermoset	Pendant or Portable	Damp Locations	Not Hard Usage
	SP-2 See Note 7.	18-16			18-16	45					
	SP-3 See Note 7.	18-12		Thermoset	18-16 14 12 10	60 80 95 110	None	Thermoset	Refrigerators, Room Air Conditioners and as permitted in Section 422-8(d)	Damp Locations	Not Hard Usage

See Notes 1 through 9.  
\* See Note 9.

**Table 400-4 (Continued)**

All Elastomer (thermoplastic) Parallel Cord	SPE-1 See Note 7.	18	2 or 3	Thermoplastic Elastomer	18	30	None	Thermoplastic Elastomer	Pendant or Portable	Damp Locations	Not Hard Usage
	SPE-2 See Note 7.	18-16			18-16	45					
	SPE-3 See Note 7.	18-12		18-16 14 12 10	60 80 95 110	None	Thermoplastic Elastomer	Refrigerators, Room Air Conditioners and as permitted in Section 422-8(d)	Damp Locations	Not Hard Usage	
All Plastic Parallel Cord	SPT-1 See Note 7.	18	2 or 3	Thermoplastic	18	30	None	Thermoplastic	Pendant or Portable	Damp Locations	Not Hard Usage
	SPT-2 See Note 7.	18-16			18-16	45					
	SPT-3 See Note 7.	18-10		18-16 14 12 10	60 80 95 110	None	Thermoplastic	Refrigerators, Room Air Conditioners and as permitted in Section 422-8(d)	Damp Locations	Not Hard Usage	

See Notes 1 through 9.

\* See Note 9.

Table 400-4 (Continued)

Trade Name	Type Letter	Size AWG	No. of Conductors	Insulation	Nominal Insulation Thickness		Braid on Each Conductor	Outer Covering	Use		
					AWG	Mils					
Range, Dryer Cable	SRD	10-4	3 or 4	Thermoset	10-4	45	None	Thermoset	Portable	Damp Locations	Ranges, Dryers
	SRDE	10-4	3 or 4	Thermoplastic Elastomer				Thermoplastic Elastomer			
	SRDT	10-4	3 or 4	Thermoplastic				Thermoplastic			
Hard Service Cord	ST See Note 5.	18-2	2 or more	Thermoplastic or Thermoset	18-16 14-10 8- 2	30 45 60	None	Thermoplastic	Pendant or Portable	Damp Locations	Extra Hard Usage
	STO See Note 5.							Oil-Resistant Thermoplastic			
	STOO See Note 5.			Oil-Resistant Thermoplastic or Thermoset							
Vacuum Cleaner Cord	SV See Note 7.	18-17	2 or 3	Thermoset	18-17	15	None	Thermoset	Pendant or Portable	Damp Locations	Not Hard Usage
	SVE See Note 7.			Thermoplastic Elastomer							
	SVO			Thermoset							

See Notes 1 through 9.

\* See Note 9.

Table 400-4 (Continued)

Vacuum Cleaner Cord	SVOO	18-17	2 or 3	Oil-Resistant Thermoset	18-17	15	None	Oil-Resistant Thermoset	Pendant or Portable	Damp Locations	Not Hard Usage
	SVT See Note 7.			Thermoset or Thermoplastic				Thermoplastic			
	SVTO See Note 7.			Thermoset or Thermoplastic				Oil-Resistant Thermoplastic			
	SVTOO			Oil-Resistant Thermoplastic or Thermoset				Oil-Resistant Thermoplastic			
Parallel Tinsel Cord	TPT See Note 3.	27	2	Thermoplastic	27	30	None	Thermoplastic	Attached to an Appliance	Damp Locations	Not Hard Usage
Jacketed Tinsel Cord	TS See Note 3.	27	2	Thermoset	27	15	None	Thermoset	Attached to an Appliance	Damp Locations	Not Hard Usage
	TST See Note 3.	27	2	Thermoplastic			None	Thermoplastic	Attached to an Appliance	Damp Locations	Not Hard Usage
Portable Power Cable	W	8-500 MCM	1-6	Thermoset	8-2 1-4/0 250MCM- 500MCM	60 80 95		Oil-Resistant Thermoset	Portable, Extra Hard Usage, and as Permitted in Sections 520-68 and 530-12.		

See Notes 1 through 9.

\* See Note 9.

telephone, audio or higher frequency communication circuits; the coaxial cables consist of a center conductor, insulation and shield for use in video or other radio frequency communication circuits. The insulation of the conductors shall be rubber or thermoplastic of thickness not less than specified for the other conductors of the particular type of cable. Metallic shields shall have their own protective covering. Where used, these components shall be permitted to be incorporated in any layer of the cable assembly but shall not run straight through the center.

7. A third conductor in these cables is for grounding purposes only.

8. The individual conductors of all cords, except those of heat-resistant cords (Types AFC, AFPD, AFPO, AFS, and AFSJ), shall have a thermoset or thermoplastic insulation, except that the grounding conductor where used shall be in accordance with Section 400-23(b). Unvulcanized rubber compounds shall be permitted to be used for all sizes of heater cord Types HSJ and HSJO, and for sizes 18 and 16 AWG Type HPD.

9. Where the voltage between any two conductors exceeds 300, but does not exceed 600, flexible cord of No. 10 and smaller shall have thermoset or thermoplastic insulation on the individual conductors at least 45 mils in thickness, unless Type S, SO, SE, SEO, SOO, ST, STO, or STOO cord is used.

**400-5. Ampacity of Flexible Cords and Cables.** Table 400-5 gives the allowable ampacity for not more than three current-carrying copper conductors in a cord. If the number of current-carrying conductors in a cord exceeds three, the ampacity of each conductor shall be reduced from the 3-conductor rating as shown in the following table:

Number of Conductors	Percent of Values in Table 400-5
4 through 6	80
7 through 24	70
25 through 42	60
43 and above	50

Subheading C of Table 400-5 gives the allowable ampacity for single-conductor Type W cable only where the individual conductors are not installed in raceways and are not in physical contact with each other except in lengths not to exceed 24 inches when passing through the wall of an enclosure.

A neutral conductor which carries only the unbalanced current from other conductors, as in the case of normally balanced circuits of three or more conductors, shall not be considered as a current-carrying conductor.

In a 3-wire circuit consisting of 2 phase wires and the neutral of a 4-wire, 3-phase wye-connected system, a common conductor carries approximately the same current as the other conductors and shall be considered a current-carrying conductor.

On a 4-wire, 3-phase wye circuit where the major portion of the load consists of electric-discharge lighting, data processing, or similar equipment, there are harmonic currents present in the neutral conductor and the neutral shall be considered to be a current-carrying conductor.

**Table 400-5. Ampacity of Flexible Cords and Cables**

[Based on Ambient Temperature of 30° C (86°F). See Section 400-13 and Table 400-4.]

Size AWG	Thermoset Types TS	Thermoset Types C, E, EN, EO, G, PD, S, SJ, SJO, SJO, SO, SOO, SP, SP-1, SP-2, SP-3, SRD, SV, SVO, SVOO, W			Types AFS, AFSJ, HPD, HPN, HS, HSJ, HSO	Asbestos Types AFC* AFPD* AFPO
	Thermo- plastic Types TPT, TST	Thermoplastic. Types ET, ETT, ETLB, ETP, SE, SEO, SJE, SJO, SJT, SJTO, SJTOO, SPE-1, SPE-2, SPE-3, SPT, SPT-1, SPT-2, SPT-3, ST, STO, STOO, SRDE, SRDT, SVE, SVEO, SVT, SVTO, SVTOO				
27**	0.5	A†	B†	C	..	..
20	..	5***	7***	..	..	..
18	..	7	10	..	10	6
17	..	..	12	..	..	..
16	..	10	13	..	15	8
15	..	..	..	..	17	..
14	..	15	18	..	20	17
12	..	20	25	..	30	23
10	..	25	30	..	35	28
8	..	35	40	60	..	..
6	..	45	55	80	..	..
4	..	60	70	105	..	..
2	..	80	95	140	..	..
1	..	90	110	165	..	..
1/0	..	100	125	195	..	..
2/0	..	115	145	225	..	..
3/0	..	130	165	260	..	..
4/0	..	155	195	300	..	..
250 MCM	..	170	215	340	..	..
300 MCM	..	190	240	375	..	..
350 MCM	..	210	260	420	..	..
400 MCM	..	225	280	455	..	..
500 MCM	..	255	320	515	..	..

\* These types are used almost exclusively in fixtures where they are exposed to high temperatures and ampere ratings are assigned accordingly.

\*\* Tinsel cord.

\*\*\* Elevator cables only.

† The ampacities under sub-heading A apply to 3-conductor cords and other multiconductor cords connected to utilization equipment so that only 3 conductors are current carrying. The ampacities under sub-heading B apply to 2-conductor cords and other multiconductor cords connected to utilization equipment so that only 2 conductors are current carrying.

NOTE. Ultimate Insulation Temperature. In no case shall conductors be associated together in such a way with respect to the kind of circuit, the wiring method used, or the number of conductors that the limiting temperature of the conductors will be exceeded.



An equipment grounding conductor shall not be considered a current-carrying conductor.

Where a single conductor is used for both equipment grounding and to carry unbalanced current from other conductors, as provided for in Section 250-60 for electric ranges and electric clothes dryers, it shall not be considered as a current-carrying conductor.

**400-6. Marking.** Flexible cords and cables shall be marked by means of a printed tag attached to the coil reel or carton. The tag shall contain the information required in Section 310-11(a).

Types SJ, SJE, SJO, SJEO, SJT, SJTO, SJTOO, S, SE, SEO, SO, SOO, ST, STO and STOO flexible cords and G and W flexible cables shall be durably marked on the surface at intervals not exceeding 24 inches (610 mm) with the type designation, size, and number of conductors.

**400-7. Uses Permitted.**

(a) **Uses.** Flexible cords and cables shall be used only for (1) pendants; (2) wiring of fixtures; (3) connection of portable lamps or appliances; (4) elevator cables; (5) wiring of cranes and hoists; (6) connection of stationary equipment to facilitate their frequent interchange; (7) prevention of the transmission of noise or vibration; (8) appliances where the fastening means and mechanical connections are designed to permit removal for maintenance and repair; (9) data processing cables as permitted by Section 645-2; (10) connection of moving parts; or (11) temporary wiring as permitted in Sections 305-4(b) and 305-4(c).

(b) **Attachment Plugs.** Where used as permitted in subsections (a)(3), (a)(6), and (a)(8) of this section, each flexible cord shall be equipped with an attachment plug and shall be energized from a receptacle outlet.

**400-8. Uses Not Permitted.** Unless specifically permitted in Section 400-7 flexible cords and cables shall not be used (1) as a substitute for the fixed wiring of a structure; (2) where run through holes in walls, ceilings, or floors; (3) where run through doorways, windows, or similar openings; (4) where attached to building surfaces; or (5) where concealed behind building walls, ceilings, or floors.

**400-9. Splices.** Flexible cord shall be used only in continuous lengths without splice or tap when initially installed in applications permitted by Section 400-7(a). The repair of hard service cord (see Column 1, Table 400-4) No. 14 and larger shall be permitted if conductors are spliced in accordance with Section 110-14(b) and the completed splice retains the insulation, outer sheath properties, and usage characteristics of the cord being spliced.

**400-10. Pull at Joints and Terminals.** Flexible cords shall be so connected to devices and to fittings that tension will not be transmitted to joints or terminals.

(FPN): Some methods of preventing pull on a cord from being transmitted to joints or terminals are (1) knotting the cord, (2) winding with tape, and (3) fittings designed for the purpose.

**400-11. In Show Windows and Show Cases.** Flexible cords used in show windows and show cases shall be Type S, SO, SE, SEO, SOO, SJ, SJE, SJO, SJEO, SJOO, ST, STO, STOO, SJT, SJTO, SJTOO, or AFS.

*Exception No. 1: For the wiring of chain-supported lighting fixtures.*

*Exception No. 2: As supply cords for portable lamps and other merchandise being displayed or exhibited.*

**400-12. Minimum Size.** The individual conductors of a flexible cord or cable shall not be smaller than the sizes in Table 400-4.

**400-13. Overcurrent Protection.** Flexible cords not smaller than No. 18, and tinsel cords or cords having equivalent characteristics of smaller size approved for use with specific appliances, shall be considered as protected against overcurrent by the overcurrent devices described in Section 240-4.

**400-14. Protection from Damage.** Flexible cords and cables shall be protected by bushings or fittings where passing through holes in covers, outlet boxes, or similar enclosures.

### B. Construction Specifications

**400-20. Labels.** Flexible cords shall be examined and tested at the factory and labeled before shipment.

**400-21. Nominal Insulation Thickness.** The nominal thickness of insulation for conductors of flexible cords and cables shall not be less than specified in Table 400-4.

**400-22. Grounded-Conductor Identification.** One conductor of flexible cords which is intended to be used as a grounded circuit conductor shall have a continuous marker readily distinguishing it from the other conductor or conductors. The identification shall consist of one of the methods indicated in (a) through (f) below.

(a) **Colored Braid.** A braid finished to show a white or natural gray color and the braid on the other conductor or conductors finished to show a readily distinguishable solid color or colors.

(b) **Tracer in Braid.** A tracer in a braid of any color contrasting with that of the braid and no tracer in the braid of the other conductor or conductors. No tracer shall be used in the braid of any conductor of a flexible cord which contains a conductor having a braid finished to show white or natural gray.

*Exception: In the case of Types C and PD, and cords having the braids on the individual conductors finished to show white or natural gray. In such cords the identifying marker shall be permitted to consist of the solid white or natural gray finish on one conductor, provided there is a colored tracer in the braid of each other conductor.*

(c) **Colored Insulation.** A white or natural gray insulation on one conductor and insulation of a readily distinguishable color or colors on the other conductor or conductors for cords having no braids on the individual conductors.

For jacketed cords furnished with appliances, one conductor having its insulation colored light blue, with the other conductors having their insulation of a readily distinguishable color other than white or natural gray.

*Exception: Cords which have insulation on the individual conductors integral with the jacket.*

It shall be permissible to cover the insulation with an outer finish to provide the desired color.

(d) **Colored Separator.** A white or natural gray separator on one conductor and a separator of a readily distinguishable solid color on the other conductor or conductors of cords having insulation on the individual conductors integral with the jacket.

(e) **Tinned Conductors.** One conductor having the individual strands tinned and the other conductor or conductors having the individual strands untinned for cords having insulation on the individual conductors integral with the jacket.

(f) **Surface Marking.** One or more stripes, ridges, or grooves so located on the exterior of the cord as to identify one conductor for cords having insulation on the individual conductors integral with the jacket.

**400-23. Grounding-Conductor Identification.** A conductor intended to be used as a grounding conductor shall have a continuous identifying marker readily distinguishing it from the other conductor or conductors. Conductors having a continuous green color or a continuous green color with one or more yellow stripes shall not be used for other than grounding purposes. The identifying marker shall consist of one of the methods in (a) or (b) below.

(a) **Colored Braid.** A braid finished to show a continuous green color or a continuous green color with one or more yellow stripes.

(b) **Colored Insulation or Covering.** For cords having no braids on the individual conductors, an insulation of a continuous green color or a continuous green color with one or more yellow stripes.

**400-24. Attachment Plugs.** Where a flexible cord is provided with a grounding conductor and equipped with an attachment plug, the attachment plug shall comply with Section 250-59(a) and (b).

### C. Portable Cables Over 600 Volts, Nominal

**400-30. Scope.** This part applies to multiconductor portable cables used to connect mobile equipment and machinery.

**400-31. Construction.**

(a) **Conductors.** The conductors shall be No. 8 AWG copper or larger and shall employ flexible stranding.

(b) **Shields.** Cables operated at over 2000 volts shall be shielded. Shielding shall be for the purpose of confining the voltage stresses to the insulation.

(c) **Grounding Conductor(s).** Grounding conductor(s) shall be provided. The total area shall be not less than that of the size of the conductor required in Section 250-95.

**400-32. Shielding.** All shields shall be grounded.

**400-33. Grounding.** Grounding conductors shall be connected in accordance with Part K of Article 250.

**400-34. Minimum Bending Radii.** The minimum bending radii for portable cables during installation and handling in service shall be adequate to prevent damage to the cable.

**400-35. Fittings.** Connectors used to connect lengths of cable in a run shall be of a type which lock firmly together. Provisions shall be made to prevent opening or closing these connectors while energized. Suitable means shall be used to eliminate tension at connectors and terminations.

**400-36. Splices and Terminations.** Portable cables shall not be operated with splices unless the splices are of the permanent molded, vulcanized types in accordance with Section 110-14(b). Terminations on high-voltage portable cables shall be accessible only to authorized and qualified personnel.

## ARTICLE 402 — FIXTURE WIRES

**402-1. Scope.** This article covers general requirements and construction specifications for fixture wires.

**402-2. Other Articles.** Fixture wires shall comply with this article and also with the applicable provisions of other articles of this Code.

(FPN): For application in lighting fixtures, see Article 410.

**402-3. Types.** Fixture wires shall be of a type listed in Table 402-3, and they shall comply with all requirements of that table. The fixture wires listed in Table 402-3 are all suitable for service at 600 volts, nominal, unless otherwise specified.

(FPN): Thermoplastic insulation may stiffen at temperatures colder than minus 10°C (plus 14°F), requiring care be exercised during installation at such temperatures. Thermoplastic insulation may also be deformed at normal temperatures where subjected to pressure, requiring care be exercised during installation and at points of support.

**402-5. Ampacity of Fixture Wires.** The ampacity of fixture wire shall not exceed the following:

Table 402-5

Size (AWG)	Ampacity
18	6
16	8
14	17
12	23
10	28

No conductor shall be used under such conditions that its operating temperature will exceed the temperature specified in Table 402-3 for the type of insulation involved.

(FPN): See Section 310-10 for temperature limitation of conductors.

**402-6. Minimum Size.** Fixture wires shall not be smaller than No. 18.

**402-7. Number of Conductors in Conduit.** The number of fixture wires permitted in a single conduit shall be as given in Table 2 of Chapter 9.

Table 402-3. Fixture Wire

Trade Name	Type Letter	Insulation	AWG	Thickness of Insulation Mils	Outer Covering	Max. Operating Temp.	Application Provisions
Heat-Resistant Rubber-Covered Fixture Wire Solid or 7-Strand	RFH-1	Heat-Resistant Rubber	18	15	Nonmetallic Covering	75°C 167°F	Fixture wiring. Limited to 300 volts.
	RFH-2	Heat-Resistant Rubber	18-16	30	Nonmetallic Covering	75°C 167°F	Fixture wiring, and as permitted in Sections 725-16 and 760-16.
Heat-Resistant Latex Rubber		18-16	18				
Heat-Resistant Cross-Linked Synthetic Polymer-Insulated Fixture Wire—Solid or Stranded	RFHH-2	Cross-Linked Synthetic Polymer	18-16	30	None or Nonmetallic Covering	90°C 194°F	Fixture wiring, and as permitted in Sections 725-16 and 760-16. Multiconductor cable as permitted in Sections 725-16 and 760-16.
	RFHH-3		18-16	45			
Heat-Resistant Rubber-Covered Fixture Wire Flexible Stranding	FFH-2	Heat-Resistant Rubber	18-16	30	Nonmetallic Covering	75°C 167°F	Fixture wiring, and as permitted in Section 725-16.
		Heat-Resistant Latex Rubber	18-16	18			

**Table 402-3 (Continued)**

Thermoplastic-Covered Fixture Wire—Solid or 7-Strand	TF	Thermoplastic 18-16 .....30	None	60°C 140°F	Fixture wiring, and as permitted in Sections 725-16 and 760-16.
Thermoplastic-Covered Fixture Wire—Flexible Stranding	TFF	Thermoplastic 18-16 .....30	None	60°C 140°F	Fixture wiring, and as permitted in Section 725-16.
Heat-Resistant Thermoplastic-Covered Fixture Wire—Solid or 7-Strand	TFN	Thermoplastic 18-16 .....15	Nylon Jacketed or equivalent	90°C 194°F	Fixture wiring, and as permitted in Sections 725-16 and 760-16.
Heat-Resistant Thermoplastic-Covered Fixture Wire—Flexible Stranded	TFFN	Thermoplastic 18-16 .....15	Nylon Jacketed or equivalent	90°C 194°F	Fixture wiring, and as permitted in Section 725-16.

Table 402-3 (Continued).

Trade Name	Type Letter	Insulation	AWG	Thickness of Insulation		Outer Covering	Max. Operating Temp.	Application Provisions
				Mils	Mils			
Asbestos Covered Heat-Resistant Fixture Wire	AF	Impregnated Asbestos or Moisture-Resistant Insulation and Impregnated Asbestos	18-14	—	30	None	150°C 302°F	Fixture wiring. Limited to 300 volts and indoor dry locations.
				20	10			
			12-10	—	45 20			
Silicone Insulated Fixture Wire Solid or 7-Strand	SF-1	Silicone Rubber	18		15	Nonmetallic Covering	200°C 392°F	Fixture wiring. Limited to 300 volts.
	SF-2	Silicone Rubber	18-14		30	Nonmetallic Covering	200°C 392°F	Fixture wiring, and as permitted in Sections 725-16 and 760-16.
Silicone Insulated Fixture Wire Flexible Stranding	SFF-1	Silicone Rubber	18		15	Nonmetallic Covering	150°C 302°F	Fixture wiring. Limited to 300 volts.

**Table 402-3 (Continued)**

Silicone-Insulated Fixture Wire Flexible Stranding	SFF-2	Silicone Rubber	18-14 ..... 30	Nonmetallic Covering	150°C 302°F	Fixture wiring, and as permitted in Section 725-16.
Fluorinated Ethylene Propylene Fixture Wire Solid or 7-Strand	PF	Fluorinated Ethylene Propylene	18-14 ..... 20	None	200°C 392°F	Fixture wiring, and as permitted in Sections 725-16 and 760-16.
	PGF		18-14 ..... 14	Glass Braid		
Fluorinated Ethylene Propylene Fixture Wire Flexible Stranding	PFF	Fluorinated Ethylene Propylene	18-14 ..... 20	None	150°C 302°F	Fixture wiring, and as permitted in Section 725-16.
	PGFF		18-14 ..... 14	Glass Braid		
Tape Insulated Fixture Wire Solid or 7-Strand	KF-1	Aromatic Polyimide Tape	18-10 ..... 5.5	None	200°C 392°F	Fixture wiring, Limited to 300 volts.
	KF-2	Aromatic Polyimide Tape	18-10 ..... 8.4	None	200°C 392°F	Fixture wiring, and as permitted in Sections 725-16 and 760-16.
Tape Insulated Fixture Wire Flexible Stranding	KFF-1	Aromatic Polyimide Tape	18-10 ..... 5.5	None	200°C 392°F	Fixture wiring, Limited to 300 volts.
	KFF-2	Aromatic Polyimide Tape	18-10 ..... 8.4	None	200°C 392°F	Fixture wiring, and as permitted in Section 725-16.



Table 402-3 (Continued)

Trade Name	Type Letter	Insulation	AWG	Thickness of Insulation Mils	Outer Covering	Max. Operating Temp.	Application Provisions
ECTFE Solid or 7-Strand	HF	Ethylene Chloro Trifluoro Ethylene	18-14	.....15	None	150°C 302°F	Fixture wiring, and as permitted in Section 725-16.
ECTFE Flexible Stranding	HFF	Ethylene Chloro Trifluoro Ethylene	18-14	.....15	None	150°C 302°F	Fixture wiring, and as permitted in Section 725-16.
Crosslinked Polyolefin Insulated Fixture Wire Solid or 7-Strand	XF	Crosslinked Polyolefin	18-14 12-10	.....30 .....45	None	150°C 302°F	Fixture wiring. Limited to 300 volts.
Crosslinked Polyolefin Insulated Fixture Wire Flexible Stranded	XFF	Crosslinked Polyolefin	18-14 12-10	.....30 .....45	None	150°C 302°F	Fixture wiring. Limited to 300 volts.
Modified ETFE Solid or 7-Strand	ZF	Modified Ethylene Tetrafluoro-ethylene	18-14	.....15	None	150°C 302°F	Fixture wiring, and as permitted in Sections 725-16 and 760-16.

**Table 402-3 (Continued)**

Flexible Stranding	ZFF	Modified Ethylene Tetrafluoroethylene	18-14 .....15	None	150°C 302°F	Fixture wiring, and as permitted in Section 725-16.
Extruded Polytetrafluoroethylene Solid or 7-Strand (Nickel or Nickel-Coated Copper)	PTF	Extruded Polytetrafluoroethylene	18-14 .....20	None	250°C 482°F	Fixture wiring, and as permitted in Sections 725-16 and 760-16. (Nickel or nickel-coated copper)
Extruded Polytetrafluoroethylene Flexible Stranding (No. 26-36 AWG Silver or Nickel-Coated Copper)	PTFF	Extruded Polytetrafluoroethylene	18-14 .....20	None	150°C 302°F	Fixture wiring, and as permitted in Section 725-16. (Silver or nickel-coated copper)
Perfluoroalkoxy Solid or 7-Strand (Nickel or Nickel-Coated Copper)	PAF	Perfluoroalkoxy	18-14 .....20	None	250°C 482°F	Fixture wiring, and as permitted in Sections 725-16 and 760-16. (Nickel or nickel-coated copper)
Perfluoroalkoxy Flexible Stranding	PAFF	Perfluoroalkoxy	18-14 .....20	None	150°C 302°F	Fixture wiring, and as permitted in Section 725-16.

**402-8. Grounded-Conductor Identification.** One conductor of fixture wires which is intended to be used as a grounded conductor shall be identified by means of stripes or by the means described in Section 400-22(a) through (e).

**402-9. Marking.**

(a) **Required Information.** All fixture wires shall be marked to indicate the information required in Section 310-11(a).

(b) **Method of Marking.** Thermoplastic-insulated fixture wire shall be durably marked on the surface at intervals not exceeding 24 inches (610 mm). All other fixture wire shall be marked by means of a printed tag attached to the coil, reel, or carton.

**402-10. Uses Permitted.** Fixture wires shall be permitted: (1) for installation in lighting fixtures and in similar equipment where enclosed or protected and not subject to bending or twisting in use, or (2) for connecting lighting fixtures to the branch-circuit conductors supplying the fixtures.

**402-11. Uses Not Permitted.** Fixture wires shall not be used as branch-circuit conductors.

*Exception: As permitted by Section 725-16 for Class 1 circuits and Section 760-16 for fire protective signaling circuits.*

**402-12. Overcurrent Protection.** Overcurrent protection for fixture wires shall be as specified in Section 240-4.

## ARTICLE 410 — LIGHTING FIXTURES, LAMPHOLDERS, LAMPS, RECEPTACLES, AND ROSETTES.

### A. General

**410-1. Scope.** This article covers lighting fixtures, lampholders, pendants, receptacles, and rosettes, incandescent filament lamps, arc lamps, electric-discharge lamps, the wiring and equipment forming part of such lamps, fixtures and lighting installations.

**410-2. Application to Other Articles.** Equipment for use in hazardous (classified) locations shall conform to Articles 500 through 517.

**410-3. Live Parts.** Fixtures, lampholders, lamps, rosettes, and receptacles shall have no live parts normally exposed to contact. Exposed accessible terminals in lampholders, receptacles, and switches shall not be installed in metal fixture canopies or in open-bases of portable table or floor lamps.

*Exception: Cleat-type lampholders, receptacles, and rosettes located at least 8 feet (2.44 m) above the floor shall be permitted to have exposed contacts.*

## B. Fixture Locations

### 410-4. Fixtures in Specific Locations.

(a) **Wet and Damp Locations.** Fixtures installed in wet or damp locations shall be so installed that water cannot enter or accumulate in wiring compartments, lampholders, or other electrical parts. All fixtures installed in wet locations shall be marked, "Suitable for Wet Locations." All fixtures installed in damp locations shall be marked, "Suitable for Wet Locations" or "Suitable for Damp Locations."

Installations underground or in concrete slabs or masonry in direct contact with the earth, and locations subject to saturation with water or other liquids, such as locations exposed to weather and unprotected, vehicle washing areas, and like locations, shall be considered to be wet locations with respect to the above requirement.

Interior locations protected from weather but subject to moderate degrees of moisture, such as some basements, some barns, some cold-storage warehouses and the like, the partially protected locations under canopies, marquees, roofed open porches, and the like, shall be considered to be damp locations with respect to the above requirement.

(FPN): See Article 680 for lighting fixtures in swimming pools, fountains, and similar installations.

(b) **Corrosive Locations.** Fixtures installed in corrosive locations shall be of a type suitable for such locations.

(FPN): See Section 210-7 for receptacles in fixtures.

(c) **In Ducts or Hoods.** Fixtures shall be permitted to be installed in cooking hoods of nonresidential occupancies where all of the following conditions are met:

(1) The fixture shall be identified for use within commercial cooking hoods and installed so that the temperature limits of the materials used are not exceeded.

(2) The fixture shall be so constructed that all exhaust vapors, grease, oil or cooking vapors are excluded from the lamp and wiring compartment. Diffusers shall be resistant to thermal shock.

(3) Parts of the fixture exposed within the hood shall be corrosion resistant or protected against corrosion and the surface shall be smooth so as not to collect deposits and facilitate cleaning.

(4) Wiring methods and materials supplying the fixture(s) shall not be exposed within the cooking hood.

(FPN): See Section 110-11.

(d) **Pendants.** No parts of cord-connected fixtures, hanging fixtures, or pendants shall be located within a zone measured 3 feet (914 mm) horizontally and 8 feet (2.44 m) vertically from the top of the bathtub rim. This zone is all encompassing and includes the zone directly over the tub.

**410-5. Fixtures Near Combustible Material.** Fixtures shall be so constructed, or installed, or equipped with shades or guards that combustible material will not be subjected to temperatures in excess of 90°C (194°F).

**410-6. Fixtures Over Combustible Material.** Lampholders installed over highly combustible material shall be of the unswitched type. Unless an individual switch is provided for each fixture, lampholders shall be located at

least 8 feet (2.44 m) above the floor, or shall be so located or guarded that the lamps cannot be readily removed or damaged.

**410-7. Fixtures in Show Windows.** Externally wired fixtures shall not be used in a show window.

*Exception: Fixtures of the chain-supported type shall be permitted to be externally wired.*

**410-8. Fixtures in Clothes Closets.**

(a) **Location.** A fixture in a clothes closet shall be permitted to be installed:

(1) On the wall above the closet door, provided the clearance between the fixture and a storage area where combustible material may be stored within the closet is not less than 18 inches (457 mm), or

(2) On the ceiling over an area which is unobstructed to the floor, maintaining an 18-inch (457-mm) clearance horizontally between the fixture and a storage area where combustible material may be stored within the closet.

A flush recessed fixture with a solid lens or a ceiling-mounted fluorescent fixture shall be permitted to be installed provided there is a 6-inch (152-mm) clearance, horizontally, between the fixture and the storage area.

(b) **Pendants.** Pendants shall not be installed in clothes closets.

**410-9. Space for Cove Lighting.** Coves shall have adequate space and shall be so located that lamps and equipment can be properly installed and maintained.

### C. Provisions at Fixture Outlet Boxes, Canopies, and Pans

**410-10. Space for Conductors.** Canopies and outlet boxes taken together shall provide adequate space so that fixture conductors and their connecting devices can be properly installed.

**410-11. Temperature Limit of Conductors in Outlet Boxes.** Fixtures shall be of such construction or so installed that the conductors in outlet boxes shall not be subjected to temperatures greater than that for which the conductors are rated.

Branch-circuit wiring shall not be passed through an outlet box that is an integral part of an incandescent fixture unless the fixture is identified for through wiring.

**410-12. Outlet Boxes to Be Covered.** In a completed installation, each outlet box shall be provided with a cover unless covered by means of a fixture canopy, lampholder, receptacle, rosette, or similar device.

**410-13. Covering of Combustible Material at Outlet Boxes.** Any combustible wall or ceiling finish exposed between the edge of a fixture canopy or pan and an outlet box shall be covered with noncombustible material.

**410-14. Connection of Electric-Discharge Lighting Fixtures.**

(a) **Independently of the Outlet Box.** Where electric-discharge lighting fixtures are supported independently of the outlet box, they shall be connected through metal raceways, metal-clad cables, or nonmetallic-sheathed cables.

*Exception: Cord-connected fixtures shall be permitted as provided in Sections 410-30(b) and (c).*

(b) **Access to Boxes.** Electric discharge lighting fixtures surface mounted over concealed outlet, pull, or junction boxes shall be installed with suitable openings in back of the fixture to provide access to the boxes.

**D. Fixture Supports**

**410-15. Supports.**

(a) **General.** Fixtures, lampholders, rosettes, and receptacles shall be securely supported. A fixture that weighs more than 6 pounds (2.72 kg) or exceeds 16 inches (406 mm) in any dimension shall not be supported by the screw shell of a lampholder.

(b) **Metal Poles Supporting Lighting Fixtures.** Metal poles shall be permitted to be used to support lighting fixtures and enclose supply conductors, provided that the following conditions are met.

(1) An accessible handhole not less than 2 inches (50.8 mm) × 4 inches (102 mm) having a raintight cover shall provide access to the supply raceway or cable termination within the pole or pole base. Where raceway risers or cable are not installed within the pole, a threaded fitting or nipple shall be brazed or welded to the pole opposite the handhole, for the supply connection. Other poles shall be permitted to be field welded, brazed, or tapped. Such poles shall be capped or covered.

(2) A terminal for grounding the pole shall be provided; it shall be accessible from the handhole.

(3) Metal raceways or other equipment grounding conductors shall be bonded to the pole with an equipment grounding conductor recognized by Section 250-91(b) and sized in accordance with Section 250-95.

(4) Conductors in vertical metal poles used as raceways shall be supported as provided in Section 300-19.

**410-16. Means of Support.**

(a) **Outlet Boxes.** Where the outlet box or fitting will provide adequate support, a fixture shall be attached thereto or be supported as required by Section 370-13 for boxes. A fixture that weighs more than 50 pounds (22.7 kg) shall be supported independently of the outlet box.

(b) **Inspection.** Fixtures shall be so installed that the connections between the fixture conductors and the circuit conductors can be inspected without requiring the disconnection of any part of the wiring.

*Exception: Fixtures connected by attachment plugs and receptacles.*

(c) **Suspended Ceilings.** Framing members of suspended ceiling systems used to support fixtures shall be securely fastened to each other and shall be securely attached to the building structure at appropriate intervals. Fixtures shall be securely fastened to the ceiling framing member by mechanical means, such as bolts, screws, or rivets. Clips identified for use with the type of ceiling framing member(s) and fixture(s) shall also be permitted.

(d) **Fixture Studs:** Fixture studs that are not a part of outlet boxes, hickies, tripods, and crowfeet shall be made of steel, malleable iron, or other material suitable for the application.

(e) **Insulating Joints.** Insulating joints that are not designed to be mounted with screws or bolts shall have an exterior metal casing, insulated from both screw connections.

(f) **Raceway Fittings.** Raceway fittings used to support lighting fixture(s) shall be capable of supporting the weight of the complete fixture assembly and lamp(s).

(g) **Busways.** Fixtures shall be permitted to be connected to busways in accordance with Section 364-12.

### E. Grounding

**410-17. General.** Fixtures and lighting equipment shall be grounded as provided in Part E of this article.

#### **410-18. Exposed Fixture Parts.**

(a) **With Exposed Conductive Parts.** The exposed conductive parts of lighting fixtures and equipment directly wired or attached to outlets supplied by a wiring method which provides an equipment ground shall be grounded.

(b) **Made of Insulating Material.** Fixtures directly wired or attached to outlets supplied by a wiring method which does not provide a ready means for grounding shall be made of insulating material and shall have no exposed conductive parts.

#### **410-19. Equipment Over 150 Volts to Ground.**

(a) **Metal Fixtures, Transformers, and Transformer Enclosures.** Metal fixtures, transformers, and transformer enclosures on circuits operating at over 150 volts to ground shall be grounded.

(b) **Other Exposed Metal Parts.** Other exposed metal parts shall be grounded or insulated from ground and other conducting surfaces and inaccessible to unqualified persons.

*Exception: Lamp tie wires, mounting screws, clips, and decorative bands on glass lamps spaced not less than 1½ inches (38 mm) from lamp terminals shall not be required to be grounded.*

**410-20. Equipment Grounding Conductor Attachment.** Fixtures with exposed metal parts shall be provided with a means for connecting an equipment grounding conductor for such fixtures.

**410-21. Methods of Grounding.** Fixtures and equipment shall be considered grounded where mechanically connected to an equipment grounding conductor as specified in Section 250-91(b) and sized in accordance with Section 250-95.

## F. Wiring of Fixtures

**410-22. Fixture Wiring — General.** Wiring on or within fixtures shall be neatly arranged and shall not be exposed to physical damage. Excess wiring shall be avoided. Conductors shall be so arranged that they shall not be subjected to temperatures above those for which they are rated.

**410-23. Polarization of Fixtures.** Fixtures shall be so wired that the screw shells of lampholders will be connected to the same fixture or circuit conductor or terminal. The grounded conductor, where connected to a screw-shell lampholder, shall be connected to the screw shell.

### 410-24. Conductors.

(a) **Insulation.** Fixtures shall be wired with conductors having insulation suitable for the environmental conditions, current, voltage, and temperature to which the conductors will be subjected.

(b) **Conductor Size.** Fixture conductors shall not be smaller than No. 18.

(FPN): For ampacity of fixture wire, see Table 402-5.

(FPN): For maximum operating temperature and voltage limitation of fixture wires, see Section 402-3.

### 410-25. Conductors for Certain Conditions.

(a) **Mogul-Base Lampholders.** Fixtures provided with mogul-base, screw-shell lampholders and operating at not over 300 volts between conductors shall be wired with Type AF, SF-1, SF-2, SFF-1, SFF-2, PF, PGF, PFF, PGFF, PTF, PTFF, PAF, PAFF, XF, XFF, ZF or ZFF fixture wire.

(b) **Other than Mogul-Base, Screw-Shell Lampholders.** Fixtures provided with other than mogul-base, screw-shell lampholders and operating at not over 300 volts between conductors shall be wired with Type AF, SF-1, SF-2, PF, PGF, PFF, PGFF, PTF, PTFF, PAF, PAFF, XF, XFF, ZF or ZFF fixture wire or Type AFC or AFD flexible cord.

*Exception No. 1: Where temperatures do not exceed 90°C (194°F), Types CF, TFN and TFFN fixture wire or Type CFPD flexible cord shall be permitted.*

*Exception No. 2: Where temperatures exceed 60°C (140°F) but are not higher than 75°C (167°F), Types RH and RHW rubber-covered wire and Types RFH-1, RFH-2, FFH-1, and FFH-2 fixture wires shall be permitted.*

*Exception No. 3: Where temperatures do not exceed 60°C (140°F), Type T thermoplastic wire, Types TF and TFF fixture wires shall be permitted, including fixtures of decorative types on which lamps of not over 60-watt rating are used in connection with imitation candles.*

(FPN): See Table 402-3 and Section 402-3 for fixture wires and conductors; and Table 400-5 for flexible cords.

### 410-27. Pendant Conductors for Incandescent Filament Lamps.

(a) **Support.** Pendant lampholders with permanently attached leads, where used for other than festoon wiring, shall be hung from separate stranded rubber-covered conductors that are soldered directly to the circuit conductors but supported independently thereof.



**(b) Size.** Such pendant conductors shall not be smaller than No. 14 for mogul-base or medium-base screw-shell lampholders, nor smaller than No. 18 for intermediate or candelabra-base lampholders.

*Exception: Listed Christmas tree and decorative lighting outfits shall be permitted to be smaller than No. 18.*

**(c) Twisted or Cabled.** Pendant conductors longer than 3 feet (914 mm) shall be twisted together where not cabled in a listed assembly.

#### **410-28. Protection of Conductors and Insulation.**

**(a) Properly Secured.** Conductors shall be secured in a manner that will not tend to cut or abrade the insulation.

**(b) Protection Through Metal.** Conductor insulation shall be protected from abrasion where it passes through metal.

**(c) Fixture Stems.** Splices and taps shall not be located within fixture arms or stems.

**(d) Splices and Taps.** No unnecessary splices or taps shall be made within or on a fixture.

(FPN): For approved means of making connections, see Section 110-14.

**(e) Stranding.** Stranded conductors shall be used for wiring on fixture chains and on other movable or flexible parts.

**(f) Tension.** Conductors shall be so arranged that the weight of the fixture or movable parts will not put a tension on the conductors.

**410-29. Cord-Connected Showcases.** Individual showcases, other than fixed, shall be permitted to be connected by flexible cord to permanently installed receptacles, and groups of not more than six such showcases shall be permitted to be coupled together by flexible cord and separable locking-type connectors with one of the group connected by flexible cord to a permanently installed receptacle.

The installation shall comply with (a) through (e) of this section.

**(a) Cord Requirements.** Flexible cord shall be hard-service type, having conductors not smaller than the branch-circuit conductors, having ampacity at least equal to the branch-circuit overcurrent device, and having an equipment grounding conductor.

(FPN): See Table 250-95 for size of grounding conductor.

**(b) Receptacles, Connectors, and Attachment Plugs.** Receptacles, connectors, and attachment plugs shall be of a listed grounding type rated 15 or 20 amperes.

**(c) Support.** Flexible cords shall be secured to the undersides of showcases so that: (1) wiring will not be exposed to mechanical damage; (2) a separation between cases not in excess of 2 inches (50.8 mm), nor more than 12 inches (305 mm) between the first case and the supply receptacle will be assured; and (3) the free lead at the end of a group of showcases will have a female fitting not extending beyond the case.

**(d) No Other Equipment.** Equipment other than showcases shall not be electrically connected to showcases.

**(e) Secondary Circuit(s).** Where showcases are cord connected, the secondary circuit(s) of electric discharge lighting shall be limited to one showcase.

**410-30. Cord-Connected Lampholders and Fixtures.**

(a) **Lampholders.** Where a metal lampholder is attached to a flexible cord, the inlet shall be equipped with an insulating bushing which, if threaded, shall not be smaller than nominal  $\frac{3}{8}$ -inch pipe size. The cord hole shall be of a size appropriate for the cord, and all burrs and fins shall be removed in order to provide a smooth bearing surface for the cord.

Bushing having holes  $\frac{3}{32}$  inch (7.14 mm) in diameter shall be permitted for use with plain pendant cord and holes  $\frac{1}{32}$  inch (10.3 mm) in diameter with reinforced cord.

(b) **Adjustable Fixtures.** Fixtures which require adjusting or aiming after installation shall not be required to be equipped with an attachment plug or cord connector provided the exposed cord is of the hard usage or extra-hard usage type and is not longer than that required for maximum adjustment. The cord shall not be subject to strain or physical damage.

(c) **Electric-Discharge Fixtures.** It shall be permissible to locate cord-equipped fixtures directly below the outlet box, if the cord is continuously visible for its entire length outside the fixture and is not subject to strain or physical damage. Such cord-equipped fixtures shall terminate at the outer end of the cord in a grounding-type attachment plug (cap) or busway plug.

Electric-discharge lighting fixtures provided with mogul-base, screw-shell lampholders shall be permitted to be connected to branch circuits of 50 amperes or less by cords complying with Section 240-4. Receptacles and attachment plugs shall be permitted to be of lower ampere rating than the branch circuit but not less than 125 percent of the fixture full-load current.

Electric-discharge lighting fixtures equipped with a flanged surface inlet shall be permitted to be supplied by cord pendants equipped with cord connectors. Inlets and connectors shall be permitted to be of lower ampere rating than the branch circuit but not less than 125 percent of the fixture load current.

**410-31. Fixtures as Raceways.** Fixtures shall not be used as a raceway for circuit conductors.

*Exception No. 1: Fixtures listed for use as a raceway.*

*Exception No. 2: Fixtures designed for end-to-end assembly to form a continuous raceway or fixtures connected together by recognized wiring methods shall be permitted to carry through conductors of a two-wire or multiwire branch circuit supplying the fixtures.*

*Exception No. 3: One additional two-wire branch circuit separately supplying one or more of the connected fixtures described in Exception No. 2 shall be permitted to be carried through the fixtures.*

(FPN): See Article 100 for definition of multiwire branch circuit.

Branch-circuit conductors within 3 inches (76 mm) of a ballast within the ballast compartment shall be recognized for use at temperatures not lower than 90°C (194°F), such as Types RHH, THW, THHN, FEP, FEPB, SA, XHHW, and AVA.

**G. Construction of Fixtures**

**410-34. Combustible Shades and Enclosures.** Adequate air space shall be provided between lamps and shades or other enclosures of combustible material.

**410-35. Fixture Rating.**

(a) **Marking.** All fixtures requiring ballasts or transformers shall be plainly marked with their electrical rating and the manufacturer's name, trademark, or other suitable means of identification. A fixture requiring supply wire rated higher than 90°C (194°F) shall be so marked, in letters ¼ inch (6.35 mm) high prominently displayed on the fixture and shipping carton or equivalent.

(b) **Electrical Rating.** The electrical rating shall include the voltage and frequency and shall indicate the current rating of the unit, including the ballast, transformer, or autotransformer.

**410-36. Design and Material.** Fixtures shall be constructed of metal, wood, or other material suitable for the application and shall be so designed and assembled as to secure requisite mechanical strength and rigidity. Wiring compartments, including their entrances, shall be such that conductors may be drawn in and withdrawn without physical damage.

**410-37. Nonmetallic Fixtures.** In all fixtures not made entirely of metal or noncombustible material, wiring compartments shall be lined with metal.

*Exception: Where armored or lead-covered conductors with suitable fittings are used.*

**410-38. Mechanical Strength.**

(a) **Tubing for Arms.** Tubing used for arms and stems where provided with cut threads shall not be less than 0.040 inch (0.1 mm) in thickness and where provided with rolled (pressed) threads shall not be less than 0.025 inch (0.635 mm) in thickness. Arms and other parts shall be fastened to prevent turning.

(b) **Metal Canopies.** Metal canopies supporting lampholders, shades, etc., exceeding 8 pounds (3.63 kg), or incorporating attachment-plug receptacles, shall not be less than 0.020 inch (508 micrometers) in thickness. Other canopies shall not be less than 0.016 inch (406 micrometers) if made of steel and not less than 0.020 inch (508 micrometers) if of other metals.

(c) **Canopy Switches.** Pull-type canopy switches shall not be inserted in the rims of metal canopies that are less than 0.025 inch (635 micrometers) in thickness unless the rims are reinforced by the turning of a bead or the equivalent. Pull-type canopy switches, whether mounted in the rims or elsewhere in sheet metal canopies, shall not be located more than 3½ inches (89 mm) from the center of the canopy. Double set-screws, double canopy rings, a screw ring, or equal method shall be used where the canopy supports a pull-type switch or pendant receptacle.

The above thickness requirements shall apply to measurements made on finished (formed) canopies.

**410-39. Wiring Space.** Bodies of fixtures, including portable lamps, shall provide ample space for splices and taps and for the installation of devices, if any. Splice compartments shall be of nonabsorbent, noncombustible material.

**410-42. Portable Lamps.**

(a) **General.** Portable lamps shall be wired with flexible cord, recognized by Section 400-4 and an attachment plug of the polarized or grounding type.

When used with Edison-based lampholders, the grounded conductor shall be identified and attached to the screw shell and the identified blade of the attachment plug.

**(b) Portable Handlamps.** In addition to the provisions of Section 410-42(a), portable handlamps shall comply with the following: (1) metal shell, paperlined lampholders shall not be used; (2) handlamps shall be equipped with a handle of molded composition or other insulating material; (3) handlamps shall be equipped with a substantial guard attached to the lampholder or handle; (4) metallic guards shall be grounded by the means of an equipment grounding conductor run with circuit conductors within the power supply cord.

**410-44. Cord Bushings.** A bushing or the equivalent shall be provided where flexible cord enters the base or stem of a portable lamp. The bushing shall be of insulating material unless a jacketed type of cord is used.

**410-45. Tests.** All wiring shall be free from short circuits and grounds and shall be tested for these defects prior to being connected to the circuit.

**410-46. Live Parts.** Exposed live parts within porcelain fixtures shall be suitably recessed and so located as to make it improbable that wires will come in contact with them. There shall be a spacing of at least  $\frac{1}{2}$  inch (12.7 mm) between live parts and the mounting plane of the fixture.

#### H. Installation of Lampholders

**410-47. Screw-Shell Type.** Lampholders of the screw-shell type shall be installed for use as lampholders only. Where supplied by a circuit having a grounded conductor, the grounded conductor shall be connected to the screw shell.

**410-48. Double-Pole Switched Lampholders.** Where supplied by the ungrounded conductors of a circuit, the switching device of lampholders of the switched type shall simultaneously disconnect both conductors of the circuit.

**410-49. Lampholders in Wet or Damp Locations.** Lampholders installed in wet or damp locations shall be of the weatherproof type.

#### J. Construction of Lampholders

**410-50. Insulation.** The outer metal shell and the cap shall be lined with insulating material which shall prevent the shell and cap from becoming a part of the circuit. The lining shall not extend beyond the metal shell more than  $\frac{1}{8}$  inch (3.17 mm); but shall prevent any current-carrying part of the lamp base from being exposed when a lamp is in the lampholding device.

**410-51. Lead Wires.** Lead wires, furnished as a part of weatherproof lampholders and intended to be exposed after installation, shall be of approved stranded, rubber-covered conductors not less than No. 14 and shall be sealed in place or otherwise made raintight.

*Exception: No. 18 rubber-covered conductors shall be permitted for candelabra sockets.*

**410-52. Switched Lampholders.** Switched lampholders shall be of such construction that the switching mechanism interrupts the electrical connection to the center contact. The switching mechanism shall also be permitted to interrupt the electrical connection to the screw shell if the connection to the center contact is simultaneously interrupted.

### K. Lamps and Auxiliary Equipment

**410-53. Bases, Incandescent Lamps.** An incandescent lamp for general use on lighting branch circuits shall not be equipped with a medium base if rated over 300 watts, nor with a mogul base if rated over 1500 watts. Special bases or other devices shall be used for over 1500 watts.

#### 410-54. Electric-Discharge Lamp Auxiliary Equipment.

(a) **Enclosures.** Auxiliary equipment for electric-discharge lamps shall be enclosed in noncombustible cases and treated as sources of heat.

(b) **Switching.** Where supplied by the ungrounded conductors of a circuit, the switching device of auxiliary equipment shall simultaneously disconnect all conductors.

**410-55. Arc Lamps.** Arc lamps used in theaters shall comply with Section 520-61, and arc lamps used in projection machines shall comply with Section 540-20. Arc lamps used on constant-current systems shall comply with the general requirements of Article 710.

### L. Receptacles, Cord Connectors, and Attachment Plugs (Caps)

#### 410-56. Rating and Type.

(a) **Receptacles.** Receptacles installed for the attachment of portable cords shall be rated at not less than 15 amperes, 125 volts, or 15 amperes, 250 volts, and shall be of a type not suitable for use as lampholders.

*Exception: The use of receptacles of 10-ampere, 250-volt rating used in nonresidential occupancies for the supply of equipment other than portable hand tools, portable handlamps, and extension cords shall be permitted.*

(b) **CO/ALR Receptacles.** Receptacles rated 20 amperes or less and directly connected to aluminum conductors shall be marked CO/ALR.

(c) **Faceplates.** Metal faceplates shall be of ferrous metal not less than 0.030 inch (762 micrometers) in thickness or of nonferrous metal not less than 0.040 inch (1 mm) in thickness. Metal faceplates shall be grounded. Faceplates of insulating material shall be noncombustible and not less than 0.10 inch (2.54 mm) in thickness but shall be permitted to be less than 0.10 inch (2.54 mm) in thickness if formed or reinforced to provide adequate mechanical strength.

(d) **Position of Receptacle Faces.** After installation, receptacle faces shall be flush with or project from faceplates of insulating material and shall project a minimum of 0.015 inch (381 micrometers) from metal faceplates. Faceplates shall be installed so as to completely cover the opening and seat against the mounting surface. Receptacles mounted in boxes that are set back of the wall surface, as permitted in Section 370-10, shall be installed so that the mounting yoke or strap of the receptacle is held rigidly at the surface of

the wall. Receptacles mounted in boxes that are flush with the wall surface or project therefrom shall be so installed that the mounting yoke or strap of the receptacle is seated against the box or raised box cover:

(e) **Attachment Plugs.** All 15- and 20-ampere attachment plugs and connectors shall be so constructed that there are no exposed current-carrying parts except the prongs, blades, or pins. The cover for wire terminations shall be a part, which is essential for the operation of an attachment plug or connector (dead-front construction).

(f) **Attachment Plug-Ejector Mechanisms.** Attachment plug-ejector mechanisms shall not adversely affect engagement of the blades of the attachment plug with the contacts of the receptacle.

(g) **Noninterchangeability.** Receptacles, cord connectors, and attachment plugs shall be constructed so that the receptacle or cord connectors will not accept an attachment plug with a different voltage or current rating than that for which the device is intended. Nongrounding-type receptacles and connectors shall not accept grounding-type attachment plugs:

*Exception: A 20-ampere T-slot receptacle or cord connector shall be permitted to accept a 15-ampere attachment plug of the same voltage rating.*

#### 410-57. Receptacles in Damp or Wet Locations.

(a) **Damp Locations.** A receptacle installed outdoors in a location protected from the weather or in other damp locations shall have an enclosure for the receptacle that is weatherproof when the receptacle is covered (attachment plug cap not inserted and receptacle covers closed).

An installation suitable for wet locations shall also be considered suitable for damp locations.

A receptacle shall be considered to be in a location protected from the weather where located under roofed open porches, canopies, marquees, and the like, and will not be subjected to a beating rain or water run-off.

(b) **Wet Locations.** A receptacle installed outdoors where exposed to weather or in other wet locations shall be in a weatherproof enclosure, the integrity of which is not affected when the receptacle is in use (attachment plug cap inserted).

*Exception: An enclosure that is weatherproof only when a self-closing receptacle cover is closed shall be permitted to be used for a receptacle installed outdoors where the receptacle is not to be used with other than portable tools or other portable equipment not left connected to the outlet indefinitely.*

(c) **Protection for Floor Receptacles.** Standpipes of floor receptacles shall allow floor-cleaning equipment to be operated without damage to receptacles.

(d) **Flush Mounting with Faceplate.** The enclosure for a receptacle installed in an outlet box flush-mounted on a wall surface shall be made weatherproof by means of a weatherproof faceplate assembly that provides a watertight connection between the plate and the wall surface.

(e) **Installation.** A receptacle outlet installed outdoors shall be located so that water accumulation is not likely to touch the outlet cover or plate.

**410-58. Grounding-type Receptacles, Adapters, Cord Connectors, and Attachment Plugs.**

(a) **Grounding Poles.** Grounding-type receptacles, cord connectors, and attachment plugs shall be provided with one fixed grounding pole in addition to the circuit poles.

*Exception: The grounding contacting pole of grounding-type attachment plugs on the power supply cords of portable hand-held, hand-guided, or hand-supported tools or appliances shall be permitted to be of the movable self-restoring type on circuits operating at not over 150 volts between any two conductors nor over 150 volts between any conductor and ground.*

(b) **Grounding-Pole Identification.** Grounding-type receptacles, adapters, cord connections and attachment plugs shall have a means for connection of a grounding conductor to the grounding pole. A terminal for connection to the grounding pole shall be designated by:

(1) A green-colored hexagonal headed or shaped terminal screw or nut, not readily removable; or

(2) A green-colored pressure wire connector body (a wire barrel); or

(3) A similar green-colored connection device in the case of adapters.

The grounding terminal of a grounding adapter shall be a green-colored rigid ear, lug, or similar device. The grounding connection shall be so designed that it cannot make contact with current-carrying parts of the receptacle, adapter, or attachment plug. The adapter shall be polarized.

(4) If the terminal for the equipment grounding conductor is not visible, the conductor entrance hole shall be marked with the word "Green" or otherwise identified by a distinctive green color.

(c) **Grounding Terminal Use.** A grounding terminal or grounding-type device shall not be used for purposes other than grounding.

(d) **Grounding-Pole Requirements.** Grounding-type attachment plugs and mating cord connectors and receptacles shall be so designed that the grounding connection is made before the current-carrying connections. Grounding-type devices shall be designed so grounding poles of attachment plugs cannot be brought into contact with current-carrying parts of receptacles or cord connectors.

(e) **Use.** Grounding-type attachment plugs shall be used only where an equipment ground is to be provided.

**M. Rosettes****410-59. Unapproved Types.**

(a) **Fusible Rosettes.** Fusible rosettes shall not be installed.

(b) **Separable Rosettes.** Separable rosettes that may change polarity shall not be used.

**410-60. Rosettes in Damp or Wet Locations.** Rosettes installed in damp or wet locations shall be of the weatherproof type.

**410-61. Rating.** Rosettes shall be rated at 660 watts, 250 volts, with a maximum current rating of 6 amperes.

**410-62. Rosettes for Exposed Wiring.** Rosettes for exposed wiring shall be provided with bases that shall have at least two holes for supporting screws, shall be high enough to keep the wires and terminals at least  $\frac{1}{2}$  inch (12.7 mm) from the surface wired over, and shall have a lug of insulating material under each terminal to prevent the rosette from being placed over projections that would reduce the separation to less than  $\frac{1}{2}$  inch (12.7 mm).

**410-63. Rosettes for Use with Boxes or Raceways.** Rosettes for use with conduit boxes or raceways shall have bases high enough to keep wires and terminals at least  $\frac{3}{8}$  inch (9.52 mm) from the surface wired over.

#### N. Special Provisions for Flush and Recessed Fixtures

**410-64. General.** Fixtures installed in recessed cavities in walls or ceilings shall comply with Sections 410-65 through 410-72.

##### 410-65. Temperature.

(a) **Combustible Material.** Fixtures shall be so installed that adjacent combustible material will not be subjected to temperatures in excess of 90°C (194°F).

(b) **Fire-Resistant Construction.** Where a fixture is recessed in fire-resistant material in a building of fire-resistant construction, a temperature higher than 90°C (194°F), but not higher than 150°C (302°F); shall be considered acceptable if the fixture is plainly marked that it is listed for that service.

(c) **Recessed Incandescent Fixtures.** Incandescent fixtures shall have thermal protection and shall so be identified as thermally protected.

*Exception No. 1: Recessed incandescent fixtures identified for use and installed in poured concrete.*

*Exception No. 2: Listed recessed incandescent fixtures that provide, by construction design, the equivalent temperature performance characteristics of thermally protected fixtures and are so identified.*

##### 410-66. Clearance and Installation.

(a) **Clearance.** Recessed portions of lighting fixture enclosures, other than at the points of support, shall be spaced at least  $\frac{1}{2}$  inch (12.7 mm) from combustible materials.

*Exception No. 1: Recessed fixtures identified as suitable for insulation to be in direct contact with the fixture.*

*Exception No. 2: Recessed fluorescent fixtures.*

(b) **Installation.** Thermal insulation shall not be installed within 3 inches (76 mm) of the recessed fixture enclosure, wiring compartment, or ballast, and shall not be so installed above the fixture so as to entrap heat and prevent the free circulation of air.

*Exception No. 1: Recessed fixtures identified as suitable for insulation to be in direct contact with the fixture.*

*Exception No. 2: Recessed fluorescent fixtures.*

##### 410-67. Wiring.

(a) **General.** Conductors having insulation suitable for the temperature encountered shall be used.



(b) **Circuit Conductors.** Branch-circuit conductors having an insulation suitable for the temperature encountered shall be permitted to terminate in the fixture.

(c) **Tap Conductors:** Tap conductors of a type suitable for the temperature encountered shall be permitted to run from the fixture terminal connection to an outlet box placed at least 1 foot (305 mm) from the fixture. Such tap conductors shall be in a suitable raceway of at least 4 feet (1.22 m) but not more than 6 feet (1.83 m) in length.

#### P. Construction of Flush and Recessed Fixtures

**410-68. Temperature.** Fixtures shall be so constructed that adjacent combustible material will not be subject to temperatures in excess of 90°C (194°F).

**410-69. Enclosure.** Sheet metal enclosures shall be protected against corrosion and shall not be less than No. 22 MSG.

*Exception: Where a wireway cover is within the No. 22 MSG enclosure, it shall be permitted to be of No. 24 MSG metal.*

**410-70. Lamp Wattage Marking:** Incandescent lamp fixtures shall be marked to indicate the maximum allowable wattage of lamps. The markings shall be permanently installed, in letters at least 1/4 inch (6.35 mm) high, and shall be located where visible during relamping.

**410-71. Solder Prohibited.** No solder shall be used in the construction of a fixture box.

**410-72. Lampholders.** Lampholders of the screw-shell type shall be of porcelain or other suitable insulating materials. Where used, cements shall be of the high-heat type.

#### Q. Special Provisions for Electric-Discharge Lighting Systems of 1000 Volts or Less

**410-73. General.**

(a) **Open-Circuit Voltage of 1000 Volts or Less.** Equipment for use with electric-discharge lighting systems and designed for an open-circuit voltage of 1000 volts or less shall be of a type intended for such service.

(b) **Considered as Alive.** The terminals of an electric-discharge lamp shall be considered as alive where any lamp terminal is connected to a circuit of over 300 volts.

(c) **Transformers of the Oil-Filled Type.** Transformers of the oil-filled type shall not be used.

(d) **Additional Requirements.** In addition to complying with the general requirements for lighting fixtures, such equipment shall comply with Part Q of this article.

(e) **Thermal Protection.** Where fluorescent fixtures are installed indoors, the ballasts shall have thermal protection integral within the ballast. Replacement ballasts for all fluorescent fixtures installed indoors shall also have thermal protection integral within the ballast.

*Exception to (e) above: Fluorescent fixtures with simple reactance ballasts.*

(f) **Recessed High-Intensity Discharge Fixtures.** Where recessed high-intensity discharge fixtures are installed indoors, they shall be thermally protected and shall be identified. Where fixtures are operated by remote ballasts, the ballasts shall also be thermally protected.

**410-74. Direct-Current Equipment.** Fixtures installed on direct-current circuits shall be equipped with auxiliary equipment and resistors especially designed and for direct-current operation, and the fixtures shall be so marked.

**410-75. Voltages — Dwelling Occupancies.**

(a) **Open-Circuit Voltage Exceeding 1000 Volts.** Equipment having an open-circuit voltage exceeding 1000 volts shall not be installed in dwelling occupancies.

(b) **Open-Circuit Voltage Exceeding 300 Volts.** Equipment having an open-circuit voltage exceeding 300 volts shall not be installed in dwelling occupancies unless such equipment is so designed that there will be no exposed live parts when lamps are being inserted, are in place, or are being removed.

**410-76. Fixture Mounting.**

(a) **Exposed Ballasts.** Fixtures having exposed ballasts or transformers shall be so installed that such ballasts or transformers will not be in contact with combustible material.

(b) **Combustible Low-Density Cellulose Fiberboard.** Where a surface-mounted fixture containing a ballast is to be installed on combustible low-density cellulose fiberboard, it shall be listed for this condition or shall be spaced not less than 1½ inches (38 mm) from the surface of the fiberboard. Where such fixtures are partially or wholly recessed, the provisions of Sections 410-64 through 410-72 shall apply.

(FPN): Combustible low-density cellulose fiberboard includes sheets, panels, and tiles that have a density of 20 pounds per cubic foot (320.36 kg/cu m) or less, and that are formed of bonded plant fiber material but does not include solid or laminated wood, nor fiberboard that has a density in excess of 20 pounds per cubic foot (320.36 kg/cu m) or is a material that has been integrally treated with fire-retarding chemicals to the degree that the flame spread in any plane of the material will not exceed 25, determined in accordance with tests for surface burning characteristics of building materials. See Test Method for Surface Burning Characteristics of Building Materials, ANSI/ASTM E84-1984.

**410-77. Equipment Not Integral with Fixture.**

(a) **Metal Cabinets.** Auxiliary equipment, including reactors, capacitors, resistors, and similar equipment, where not installed as part of a lighting fixture assembly, shall be enclosed in accessible, permanently installed metal cabinets.

(b) **Separate Mounting.** Separately mounted ballasts that are intended for direct connection to a wiring system shall not be required to be separately enclosed.

**410-78. Autotransformers.** An autotransformer which is used to raise the voltage to more than 300 volts, as part of a ballast for supplying lighting units, shall be supplied only by a grounded system.

**410-79. Switches.** Snap switches shall comply with Section 380-14.

### **R. Special Provisions for Electric-Discharge Lighting Systems of More than 1000 Volts**

**410-80. General.**

(a) **Open-Circuit Voltage Exceeding 1000 Volts.** Equipment for use with electric-discharge lighting systems and designed for an open-circuit voltage exceeding 1000 volts shall be of a type intended for such service.

(b) **Considered as Alive.** The terminal of an electric-discharge lamp shall be considered as alive when any lamp terminal is connected to a circuit of over 300 volts.

(c) **Additional Requirements.** In addition to complying with the general requirements for lighting fixtures, such equipment shall comply with Part R of this article.

(FPN): For signs and outline lighting, see Article 600.

**410-81. Control.**

(a) **Disconnection.** Fixtures or lamp installations shall be controlled either singly or in groups by an externally operable switch or circuit breaker that opens all ungrounded primary conductors.

(b) **Within Sight or Locked Type.** The switch or circuit breaker shall be located within sight from the fixtures or lamps, or it shall be permitted elsewhere if it is provided with a means for locking in the open position.

**410-82. Lamp Terminals and Lampholders.** Parts that must be removed for lamp replacement shall be hinged or held captive. Lamps or lampholders will be so designed that there shall be no exposed live parts when lamps are being inserted or are being removed.

**410-83. Transformer Ratings.** Transformers and ballasts shall have a secondary open-circuit voltage of not over 15,000 volts with an allowance on test of 1000 volts additional. The secondary-current rating shall not be more than 120 milliamperes if the open-circuit voltage is over 7500 volts, and not more than 240 milliamperes if the open-circuit voltage is 7500 volts or less.

**410-84. Transformer Type.** Transformers shall be enclosed and listed.

**410-85. Transformer Secondary Connections.**

(a) **High-Voltage Windings.** The high-voltage windings of transformers shall not be connected in series or in parallel.

*Exception: Two transformers, each having one end of its high-voltage winding grounded and connected to the enclosure, shall be permitted to have their high-voltage windings connected in series to form the equivalent of a midpoint grounded transformer.*

(b) **Grounded Ends of Paralleled Transformers.** The grounded ends of paralleled transformers as permitted in (a) above shall be connected by an insulated conductor not smaller than No. 14.

**410-86. Transformer Locations.**

- (a) **Accessible.** Transformers shall be accessible after installation.
- (b) **Secondary Conductors.** Transformers shall be installed as near to the lamps as practicable to keep the secondary conductors as short as possible.
- (c) **Adjacent to Combustible Materials.** Transformers shall be so located that adjacent combustible materials will not be subjected to temperatures in excess of 90°C (194°F).

**410-87. Transformer Loading.** The lamps connected to any transformer shall be of such length and characteristics as not to cause a condition of continuous overvoltage on the transformer.

**410-88. Wiring Method — Secondary Conductors.** Conductors shall be installed in accordance with Section 600-31.

**410-89. Lamp Supports.** Lamps shall be adequately supported as required in Section 600-33.

**410-90. Exposure to Damage.** Lamps shall not be located where normally exposed to physical damage.

**410-91. Marking.** Each fixture or each secondary circuit of tubing having an open-circuit voltage of over 1000 volts shall have a clearly legible marking in letters not less than ¼ inch (6.35 mm) high reading "Caution. . . volts." The voltage indicated shall be the rated open-circuit voltage.

**410-92. Switches.** Snap switches shall comply with Section 380-14.

### S. Lighting Track

**410-100. Definition.** Lighting track is a manufactured assembly designed to support and energize lighting fixtures which are capable of being readily repositioned on the track. Its length may be altered by the addition or subtraction of sections of track.

**410-101. Installation.**

(a) **Lighting Track.** Lighting track shall be permanently installed and permanently connected to a branch circuit. Only lighting track fittings shall be installed on lighting track. Lighting track fittings shall not be equipped with general-purpose receptacles.

(b) **Connected Load.** The connected load on lighting track shall not exceed the rating of the track. Lighting track shall be supplied by a branch circuit having a rating not more than that of the track.

(c) **Locations Not Permitted.** Lighting track shall not be installed: (1) where subject to physical damage; (2) in wet or damp locations; (3) where subject to corrosive vapors; (4) in storage battery rooms; (5) in hazardous (classified) locations; (6) where concealed; (7) where extended through walls or partitions; (8) less than 5 feet (1.52 m) above the finished floor except where protected from physical damage.

(d) **Support.** Fittings identified for use on lighting track shall be designed specifically for the track on which they are to be installed. They shall be securely fastened to the track, maintain polarization and grounding, and shall be designed to be suspended directly from the track.

**410-102. Track Load.** For branch-circuit calculations a maximum of 2 feet (609.6 mm) of lighting track or fraction thereof shall be considered 180 VA. Where multicircuit track is installed, the load requirement of this section shall be considered to be divided equally between the circuits.

**410-103. Heavy-Duty Track.** Heavy-duty lighting track is lighting track identified for use exceeding 20 amperes. Each fitting attached to a heavy-duty lighting track shall have individual overcurrent protection.

**410-104. Fastening.** Lighting track shall be securely mounted so that each fastening will be suitable for supporting the maximum weight of fixtures which can be installed. Unless identified for supports at greater intervals, a single section 4 feet (1.22 m) or shorter in length shall have two supports, and when installed in a continuous row each individual section of not more than 4 feet (1.22 m) in length shall have one additional support.

**410-105. Construction Requirements.**

(a) **Construction.** The housing for the lighting track system shall be of substantial construction to maintain rigidity. The conductors shall be installed within the track housing permitting insertion of a fixture, and designed to prevent tampering and accidental contact with live parts. Components of lighting track systems of different voltages shall not be interchangeable. The track conductors shall be a minimum No. 12 AWG or equal, and shall be copper. The track system ends shall be insulated and capped.

*Exception: Fittings which incorporate an integral device to reduce the line voltage for a lower voltage lamp.*

(b) **Grounding.** Lighting track shall be grounded in accordance with Article 250 and the track sections shall be securely coupled to maintain continuity of the circuitry, polarization and grounding throughout.

## ARTICLE 422 — APPLIANCES

### A. General

**422-1. Scope.** This article covers electric appliances used in any occupancy.

**422-2. Live Parts.** Appliances shall have no live parts normally exposed to contact.

*Exception: Toasters, grills, or other appliances in which the current-carrying parts at high temperatures are necessarily exposed.*

**422-3. Other Articles.** All requirements of this Code shall apply where applicable. Appliances for use in hazardous (classified) locations shall comply with Articles 500 through 517.

The requirements of Article 430 shall apply to the installation of motor-operated appliances and the requirements of Article 440 shall apply to the installation of appliances containing hermetic refrigerant motor-compressor(s), except as specifically amended in this article.

## B. Branch-Circuit Requirements

**422-5. Branch-Circuit Sizing.** This section specifies sizes of conductors capable of carrying appliance current without overheating under the conditions specified. This section shall not apply to conductors that form an integral part of an appliance.

(a) **Individual Circuits.** The rating of an individual branch circuit shall not be less than the marked rating of the appliance or the marked rating of an appliance having combined loads as provided in Section 422-32.

*Exception No. 1: For motor-operated appliances not having a marked rating the branch-circuit size shall be in accordance with Part B of Article 430.*

*Exception No. 2: For an appliance, other than a motor-operated appliance, that is continuously loaded, the branch-circuit rating shall not be less than 125 percent of the marked rating; or not less than 100 percent if the branch-circuit device and its assembly is approved for continuous loading at 100 percent of its rating.*

*Exception No. 3: Branch circuits for household cooking appliances shall be permitted to be in accordance with Table 220-19.*

(b) **Circuits Supplying Two or More Loads.** For branch circuits supplying appliance and other loads, the rating shall be determined in accordance with Section 210-23.

**422-6. Branch-Circuit Overcurrent Protection.** Branch circuits shall be protected in accordance with Section 240-3.

If a protective device rating is marked on an appliance, the branch-circuit overcurrent device rating shall not exceed the protective device rating marked on the appliance.

## C. Installation of Appliances

**422-7. General.** All appliances shall be installed in an approved manner.

**422-8. Flexible Cords.**

(a) **Heater Cords.** All cord- and plug-connected smoothing irons and electrically heated appliances that are rated at more than 50 watts and produce temperatures in excess of 121°C (250°F) on surfaces with which the cord is likely to be in contact shall be provided with one of the types of approved heater cords listed in Table 400-4.

(b) **Other Heating Appliances.** All other cord- and plug-connected electrically heated appliances shall be connected with one of the approved types of cord listed in Table 400-4, selected in accordance with the usage specified in that table.

(c) **Other Appliances.** Flexible cord shall be permitted: (1) for connection of appliances to facilitate their frequent interchange or to prevent the transmission of noise or vibration, or (2) to facilitate the removal or disconnection of appliances, that are fastened in place, for maintenance or repair.

**(d) Specific Appliances.**

(1) Electrically operated kitchen waste disposers intended for dwelling unit use and provided with a Type S, SO, ST, STO, SJ, SJO, SJT, SJTO, SP-3, SPE-3, or SPT-3, three-conductor cord terminated with a grounding-type attachment plug shall be permitted where all of the following conditions are met:

a. The length of the cord shall not be less than 18 inches (457 mm) and not over 36 inches (914 mm).

b. Receptacles shall be located to avoid physical damage to the flexible cord.

c. The receptacle shall be accessible.

(2) Built-in dishwashers and trash compactors intended for dwelling unit use and provided with a Type S, SO, ST, STO, SJ, SJO, SJT, SJTO, SP-3, SPE-3, or SPT-3, three-conductor cord terminated with a grounding-type attachment plug shall be permitted where all of the following conditions are met:

a. The length of the cord shall be 3 to 4 feet (0.914 to 1.22 m).

b. Receptacles shall be located to avoid physical damage to the flexible cord.

c. The receptacle shall be located in the space occupied by the appliance or adjacent thereto.

d. The receptacle shall be accessible.

*Exception: Listed kitchen waste disposers, dishwashers and trash compactors protected by a system of double insulation, or its equivalent, shall not be required to be grounded. Where such a system is employed, the equipment shall be distinctively marked.*

(3) The supply cord conductors and internal wiring of portable high-pressure spray washing machines shall have ground-fault circuit-interrupter protection for personnel. The ground-fault circuit-interrupter shall be identified for use with portable equipment and permitted as an integral part of the attachment plug.

**422-9. Cord- and Plug-Connected Immersion Heaters.** Electric heaters of the cord- and plug-connected immersion type shall be so constructed and installed that current-carrying parts are effectively insulated from electrical contact with the substance in which they are immersed.

**422-10. Protection of Combustible Material.** Each electrically heated appliance that is intended by size, weight, and service to be located in a fixed position shall be so placed as to provide ample protection between the appliance and adjacent combustible material.

**422-11. Stands for Cord- and Plug-Connected Appliances.** Each smoothing iron and other cord- and plug-connected electrically heated appliance intended to be applied to combustible material shall be equipped with an approved stand, which shall be permitted to be a separate piece of equipment or a part of the appliance.

**422-12. Signals for Heated Appliances.** In other than dwelling-type occupancies, each electrically heated appliance or group of appliances intended to be applied to combustible material shall be provided with a signal.

*Exception: If an appliance is provided with an integral temperature-limiting device.*

**422-13. Flatirons.** Electrically heated smoothing irons shall be equipped with an identified temperature-limiting means.

**422-14. Water Heaters.**

(a) **Storage- and Instantaneous-type Water Heaters.** Each storage- or instantaneous-type water heater shall be equipped with a temperature-limiting means in addition to its control thermostat to disconnect all ungrounded conductors, and such means shall be: (1) installed to sense maximum water temperature and, (2) either a trip-free, manually reset type or a type having a replacement element. Such water heaters shall be marked to require the installation of a temperature and pressure relief valve.

(FPN): See Listing Requirements for Relief Valves and Automatic Gas Shutoff Devices for Hot Water Supply Systems (ANSI Z21.22-1979).

*Exception: Water heaters with supply water temperature of 82°C (180°F) or above and a capacity of 60 kW or above and identified as being suitable for this use; and water heaters with a capacity of 1 gallon (3.785 L) or less and identified as being suitable for such use.*

(b) **Storage-type Water Heaters.** A branch circuit supplying a fixed storage-type water heater having a capacity of 120 gallons (454.2 L) or less shall have a rating not less than 125 percent of the nameplate rating of the water heater.

(FPN): For branch-circuit sizing, see Section 422-5(a), Exception No. 2.

**422-15. Infrared Lamp Industrial Heating Appliances.**

(a) **300 Watts or Less.** Infrared heating lamps rated at 300 watts or less shall be permitted with lampholders of the medium-base, unswitched porcelain type or other types identified as suitable for use with infrared heating lamps rated 300 watts or less.

(b) **Over 300 Watts.** Screw-shell lampholders shall not be used with infrared lamps over 300 watts rating.

*Exception: Lampholders identified as suitable for use with infrared heating lamps rated more than 300 watts.*

(c) **Lampholders.** Lampholders shall be permitted to be connected to any of the branch circuits of Article 210 and, in industrial occupancies, shall be permitted to be operated in series on circuits of over 150 volts to ground provided the voltage rating of the lampholders is not less than the circuit voltage.

Each section, panel, or strip carrying a number of infrared lampholders (including the internal wiring of such section, panel, or strip) shall be considered an appliance. The terminal connection block of each such assembly shall be considered an individual outlet.

**422-16. Grounding.** Appliances required by Article 250 to be grounded shall have exposed noncurrent-carrying metal parts grounded in the manner specified in Article 250.

(FPN): See Sections 250-42, 250-43 and 250-45 for equipment grounding of refrigerators and freezers and Sections 250-57 and 250-60 for equipment grounding of electric ranges, wall-mounted ovens, counter-mounted cooking units, and clothes dryers.



**422-17. Wall-Mounted Ovens and Counter-Mounted Cooking Units.**

(a) **Permitted to Be Cord- and Plug-Connected or Permanently Connected.** Wall-mounted ovens and counter-mounted cooking units complete with provisions for mounting and for making electrical connections shall be permitted to be permanently connected or, only for ease in servicing or for installation, cord- and plug-connected.

(b) **Separable Connector or a Plug and Receptacle Combination.** A separable connector or a plug and receptacle combination in the supply line to an oven or cooking unit shall:

(1) Not be installed as the disconnecting means required by Section 422-20.

(2) Be approved for the temperature of the space in which it is located.

**422-18. Support of Ceiling Fans.** Listed ceiling fans that do not exceed 35 pounds in weight, with or without accessories, shall be permitted to be supported by outlet boxes identified for such use and supported in accordance with Sections 370-13 and 370-17.

**422-19. Other Installation Methods.** Appliances employing methods of installation other than covered by this article shall be permitted to be used only by special permission.

**D. Control and Protection of Appliances**

**422-20. Disconnecting Means.** A means shall be provided to disconnect each appliance from all ungrounded conductors in accordance with the following sections of Part D. If an appliance is supplied by more than one source, the disconnecting means shall be grouped and identified.

**422-21. Disconnection of Permanently Connected Appliances.**

(a) **Rated at Not Over 300 Volt Amperes or 1/8 Horsepower.** For permanently connected appliances rated at not over 300 volt amperes or 1/8 horsepower, the branch-circuit overcurrent device shall be permitted to serve as the disconnecting means.

(b) **Permanently Connected Appliances of Greater Rating.** For permanently connected appliances of greater rating the branch-circuit switch or circuit breaker shall be permitted to serve as the disconnecting means where readily accessible to the user of the appliance.

(FPN): For motor-driven appliances of more than 1/8 horsepower, see Section 422-26.

*Exception: Appliances employing unit switches as permitted by Section 422-24.*

**422-22. Disconnection of Cord- and Plug-Connected Appliances.**

(a) **Separable Connector or an Attachment Plug and Receptacle.** For cord- and plug-connected appliances, an accessible separable connector or an accessible plug and receptacle shall be permitted to serve as the disconnecting means. Other cord- and plug-connected appliances shall be provided with disconnecting means in accordance with Section 422-21.

(b) **Connection at the Rear Base of a Range.** For cord- and plug-connected household electric ranges, an attachment plug and receptacle connec-

tion at the rear base of a range, if it is accessible from the front by removal of a drawer, shall be considered as meeting the intent of Section 422-22(a).

(c) **Rating.** The rating of a receptacle or of a separable connector shall not be less than the rating of any appliance connected thereto.

*Exception: Demand factors authorized elsewhere in this Code shall be permitted to be applied.*

(d) **Requirements for Attachment Plugs and Connectors.** Attachment plugs and connectors shall conform to the following:

(1) **Live Parts.** They shall be so constructed and installed as to guard against inadvertent contact with live parts.

(2) **Interrupting Capacity.** They shall be capable of interrupting their rated current without hazard to the operator.

(3) **Interchangeability.** They shall be so designed that they will not fit into receptacles of lesser rating.

(4) **Polarity.** If the appliance is provided with a single-pole switching device, the attachment plug shall be polarized or of the grounding type.

(FPN): See also Section 410-42.

**422-24. Unit Switch(es) as Disconnecting Means.** A unit switch(es) with a marked "off" position that is a part of an appliance and disconnects all ungrounded conductors shall be permitted as the disconnecting means required by this article where other means for disconnection are provided in the following types of occupancies:

(a) **Multifamily Dwellings.** In multifamily dwellings, the other disconnecting means shall be within the dwelling unit, or on the same floor as the dwelling unit in which the appliance is installed, and shall be permitted to control lamps and other appliances.

(b) **Two-Family Dwellings.** In two-family dwellings, the other disconnecting means shall be permitted either inside or outside of the dwelling unit in which the appliance is installed. In this case, an individual switch or circuit breaker for the dwelling unit shall be permitted and shall also be permitted to control lamps and other appliances.

(c) **One-Family Dwellings.** In one-family dwellings, the service disconnecting means shall be permitted to be the other disconnecting means.

(d) **Other Occupancies.** In other occupancies, the branch-circuit switch or circuit breaker, where readily accessible for servicing of the appliance, shall be permitted as the other disconnecting means.

**422-25. Switch and Circuit Breaker to Be Indicating.** Switches and circuit breakers used as disconnecting means shall be of the indicating type.

**422-26. Disconnecting Means for Motor-Driven Appliances.** If a switch or circuit breaker serves as the disconnecting means for a permanently connected motor-driven appliance of more than  $\frac{1}{8}$  horsepower, it shall be located within sight from the motor controller and shall comply with Part H of Article 430.

*Exception: A switch or circuit breaker that serves as the other disconnecting means as required in Section 422-24(a), (b), (c) or (d) shall be permitted to be out of sight from the motor controller of an appliance provided with a*

unit switch(es) with a marked "off" position and which disconnects all ungrounded conductors.

#### 422-27. Overcurrent Protection.

(a) **Appliances.** Appliances shall be protected against overcurrent in accordance with (b) through (f) below and Sections 422-5 and 422-6.

*Exception: Motors of motor-operated appliances shall be provided with overload protection in accordance with Part C of Article 430. Hermetic refrigerant motor-compressors in air-conditioning or refrigerating equipment shall be provided with overload protection in accordance with Part F of Article 440. When appliance overcurrent protective devices separate from the appliance are required, data for selection of these devices shall be marked on the appliance. The minimum marking shall be that specified in Sections 430-7 and 440-4.*

(b) **Household-type Appliance with Surface Heating Elements.** A household-type appliance with surface heating elements having a maximum demand of more than 60 amperes computed in accordance with Table 220-19 shall have its power supply subdivided into two or more circuits, each of which is provided with overcurrent protection rated at not over 50 amperes.

(c) **Infrared Lamp Commercial and Industrial Heating Appliances.** Infrared lamp commercial and industrial heating appliances shall have overcurrent protection not exceeding 50 amperes.

(d) **Open-Coil or Exposed Sheathed-Coil Types of Surface Heating Elements in Commercial-type Heating Appliances.** Open-coil or exposed sheathed-coil types of surface heating elements in commercial-type heating appliances shall be protected by overcurrent protective devices rated at not over 50 amperes.

(e) **Single Nonmotor-Operated Appliance.** If the branch circuit supplies a single nonmotor-operated appliance, the overcurrent device rating shall not exceed a protective device rating marked on the appliance or, if there is no marking, the value specified as follows:

Appliance rating not exceeding 13.3 amperes	20 amperes
Appliance rating greater than 13.3 amperes	150 percent of appliance rating.

(f) **Electric Heating Appliances Employing Resistance-type Heating Elements Rated More than 48 Amperes.** Electric heating appliances employing resistance-type heating elements rated more than 48 amperes shall have the heating elements subdivided. Each subdivided load shall not exceed 48 amperes and shall be protected at not more than 60 amperes.

These supplementary overcurrent protective devices shall be: (1) factory installed within or on the heater enclosure or provided as a separate assembly by the heater manufacturer; (2) accessible, but need not be readily accessible; and (3) suitable for branch-circuit protection.

The main conductors supplying these overcurrent protective devices shall be considered branch-circuit conductors.

*Exception No. 1: Household-type appliances with surface heating elements as covered in Section 422-27(b) and commercial-type heating appliances as covered in Section 422-27(d).*

*Exception No. 2: Commercial kitchen and cooking appliances using sheathed-type heating elements not covered in Section 422-27(d) shall be*

permitted to be subdivided into circuits not exceeding 120 amperes and protected at not more than 150 amperes where one of the following is met:

- a. Elements are integral with and enclosed within a cooking surface;
- b. Elements are completely contained within an enclosure identified as suitable for this use; or
- c. Elements are contained within an ASME rated and stamped vessel.

*Exception No. 3: Water heaters and steam boilers employing resistance-type immersion electric heating elements contained in an ASME rated and stamped vessel shall be permitted to be subdivided into circuits not exceeding 120 amperes and protected at not more than 150 amperes.*

## E. Marking of Appliances

### 422-30. Nameplate.

(a) **Nameplate Marking.** Each electric appliance shall be provided with a nameplate, giving the identifying name and the rating in volts and amperes, or in volts and watts. If the appliance is to be used on a specific frequency or frequencies, it shall be so marked.

When motor overload protection external to the appliance is required, the appliance shall be so marked.

(FPN): See Section 422-27(a), Exception for overcurrent protection requirements.

(b) **To Be Visible.** Marking shall be located so as to be visible or easily accessible after installation.

**422-31. Marking of Heating Elements.** All heating elements that are rated over one ampere, replaceable in the field, and a part of an appliance shall be legibly marked with the ratings in volts and amperes, or in volts and watts, or with the manufacturer's part number.

**422-32. Appliances Consisting of Motors and Other Loads.** Appliances shall be marked in accordance with (a) or (b) below.

(a) **Marking.** In addition to the marking required in Section 422-30, the marking on an appliance consisting of a motor with other load(s) or motors with or without other load(s) shall specify the minimum circuit size and the maximum rating of the circuit overcurrent protective device.

*Exception No. 1: Appliances factory-equipped with cords and attachment plugs, complying with Section 422-30.*

*Exception No. 2: An appliance where both the minimum circuit size and maximum rating of the circuit overcurrent protective device are not more than 15 amperes and complies with Section 422-30.*

(b) **Alternate Marking Method.** An alternate marking method shall be permitted to specify the rating of the largest motor in volts and amperes; and the additional load(s) in volts and amperes, or volts and watts in addition to the marking required in Section 422-30.

*Exception No. 1: Appliances factory-equipped with cords and attachment plugs, complying with Section 422-30.*

*Exception No. 2: The ampere rating of a motor 1/8 horsepower or less or a nonmotor load 1 ampere or less shall be permitted to be omitted unless such loads constitute the principal load.*

## ARTICLE 424 — FIXED ELECTRIC SPACE HEATING EQUIPMENT

### A. General

**424-1. Scope.** This article covers fixed electric equipment used for space heating. For the purpose of this article, heating equipment shall include heating cable, unit heaters, boilers, central systems, or other approved fixed electric space heating equipment. This article shall not apply to process heating and room air conditioning.

**424-2. Other Articles.** All requirements of this Code shall apply where applicable. Fixed electric space heating equipment for use in hazardous (classified) locations shall comply with Articles 500 through 517. Fixed electric space heating equipment incorporating a hermetic refrigerant motor-compressor shall also comply with Article 440.

#### 424-3. Branch Circuits.

**(a) Branch-Circuit Requirements.** Individual branch circuits shall be permitted to supply any size fixed electric space heating equipment.

Branch circuits supplying two or more outlets for fixed electric space heating equipment shall be rated 15, 20, or 30 amperes.

*Exception: In other than residential occupancies, fixed infrared heating equipment shall be permitted to be supplied from branch circuits rated not over 50 amperes.*

**(b) Branch-Circuit Sizing.** The ampacity of the branch-circuit conductors and the rating or setting of overcurrent protective devices supplying fixed electric space heating equipment consisting of resistance elements with or without a motor shall not be less than 125 percent of the total load of the motors and the heaters. The rating or setting of overcurrent protective devices shall be permitted in accordance with Section 240-3, Exception No. 1. A contactor, thermostat, relay, or similar device, approved for continuous operation at 100 percent of its rating, shall be permitted to supply its full-rated load as provided in Section 210-22(c), Exception No. 2.

The size of the branch-circuit conductors and overcurrent protective devices supplying fixed electric space heating equipment including a hermetic refrigerant motor-compressor with or without resistance units shall be computed in accordance with Sections 440-34 and 440-35.

The provisions of this section shall not apply to conductors which form an integral part of approved fixed electric space heating equipment.

### B. Installation

**424-9. General.** All fixed electric space heating equipment shall be installed in an approved manner.

**424-10. Special Permission.** Fixed electric space heating equipment and systems installed by methods other than covered by this article shall be permitted only by special permission.

**424-11. Supply Conductors.** Fixed electric space heating equipment requiring supply conductors with over 60°C insulation shall be clearly and

permanently marked. This marking shall be plainly visible after installation and shall be permitted to be adjacent to the field-connection box.

#### **424-12. Locations.**

(a) **Exposed to Severe Physical Damage.** Fixed electric space-heating equipment shall not be used where exposed to severe physical damage unless adequately protected.

(b) **Damp or Wet Locations.** Heaters and related equipment installed in damp or wet locations shall be approved for such locations and shall be constructed and installed so that water cannot enter or accumulate in or on wired sections, electrical components, or duct work.

(FPN): See Section 110-11 for equipment exposed to deteriorating agents.

**424-13. Spacing from Combustible Materials.** Fixed electric space heating equipment shall be installed to provide the required spacing between the equipment and adjacent combustible material, unless it has been found to be acceptable where installed in direct contact with combustible material.

**424-14. Grounding.** All exposed noncurrent-carrying metal parts of fixed electric space heating equipment likely to become energized shall be grounded as required in Article 250.

### **C. Control and Protection of Fixed Electric Space Heating Equipment**

**424-19. Disconnecting Means.** Means shall be provided to disconnect the heater, motor controller(s), and supplementary overcurrent protective device(s) of all fixed electric space heating equipment from all ungrounded conductors. Where heating equipment is supplied by more than one source, the disconnecting means shall be grouped and identified.

(a) **Heating Equipment with Supplementary Overcurrent Protection.** The disconnecting means for fixed electric space heating equipment with supplementary overcurrent protection shall be within sight from and on the supply side of the supplementary overcurrent protective device(s), and in addition shall comply with either (1) or (2) below.

(1) **Heater Containing No Motor Rated Over  $\frac{1}{8}$  Horsepower.** The above disconnecting means or unit switches complying with Section 424-19(c) shall be permitted to serve as the required disconnecting means for both the motor controller(s) and heater under either (a) or (b) below.

a. The disconnecting means provided is also within sight from the motor controller(s) and the heater; or

b. The disconnecting means provided shall be capable of being locked in the open position.

#### **(2) Heater Containing a Motor(s) Rated Over $\frac{1}{8}$ Horsepower.**

a. The above disconnecting means shall be permitted to serve as the required disconnecting means for both the motor controller(s) and heater if this disconnecting means is also in sight from the motor controller(s) and the heater.

b. Where the disconnecting means is not within sight from the heater a separate disconnecting means shall be installed, or the disconnecting means

shall be capable of being locked in the open position, or unit switches complying with Section 424-19(c) shall be permitted.

c. Where the disconnecting means is not within sight from the motor controller location a disconnecting means complying with Section 430-102 shall be provided.

d. Where the motor is not in sight from the motor controller location, Section 430-102(b) shall apply.

**(b) Heating Equipment Without Supplementary Overcurrent Protection.**

(1) **Without Motor or with Motor Not Over  $\frac{1}{8}$  Horsepower.** For fixed electric space heating equipment without a motor rated over  $\frac{1}{8}$  horsepower, the branch-circuit switch or circuit breaker shall be permitted to serve as the disconnecting means, where readily accessible for servicing.

(2) **Over  $\frac{1}{8}$  Horsepower.** For motor-driven electric space heating equipment with a motor rated over  $\frac{1}{8}$  horsepower, a disconnecting means shall be located within sight from the motor controller.

*Exception: As permitted by Section 424-19(a)(2).*

(c) **Unit Switch(es) as Disconnecting Means.** A unit switch(es) with a marked "off" position that is part of a fixed heater and disconnects all ungrounded conductors shall be permitted as the disconnecting means required by this article where other means for disconnection are provided in the following types of occupancies.

(1) **Multifamily Dwellings.** In multifamily dwellings, the other disconnecting means shall be within the dwelling unit, or on the same floor as the dwelling unit in which the fixed heater is installed, and shall also be permitted to control lamps and appliances.

(2) **Two-Family Dwellings.** In two-family dwellings, the other disconnecting means shall be permitted either inside or outside of the dwelling unit in which the fixed heater is installed. In this case, an individual switch or circuit breaker for the dwelling unit shall be permitted and shall also be permitted to control lamps and appliances.

(3) **One-Family Dwellings.** In one-family dwellings, the service disconnecting means shall be permitted to be the other disconnecting means.

(4) **Other Occupancies.** In other occupancies, the branch-circuit switch or circuit breaker, where readily accessible for servicing of the fixed heater, shall be permitted as the other disconnecting means.

**424-20. Thermostatically Controlled Switching Devices.**

(a) **Serving as Both Controllers and Disconnecting Means.** Thermostatically controlled switching devices and combination thermostats and manually controlled switches shall be permitted to serve as both controllers and disconnecting means provided all of the following conditions are met:

(1) Provided with a marked "off" position.

(2) Directly open all ungrounded conductors when manually placed in the "off" position.

(3) Designed so that the circuit cannot be energized automatically after the device has been manually placed in the "off" position.

(4) Located as specified in Section 424-19.

**(b) Thermostats that Do Not Directly Interrupt All Ungrounded Conductors.** Thermostats that do not directly interrupt all ungrounded conductors and thermostats that operate remote control circuits shall not be required to meet the requirements of (a). These devices shall not be permitted as the disconnecting means.

**424-21. Switch and Circuit Breaker to Be Indicating.** Switches and circuit breakers used as disconnecting means shall be of the indicating type.

**424-22. Overcurrent Protection.**

**(a) Branch-Circuit Devices.** Electric space heating equipment, other than such motor-operated equipment as required by Articles 430 and 440 to have additional overcurrent protection, shall be permitted to be protected against overcurrent where supplied by one of the branch circuits in Article 210.

**(b) Resistance Elements.** Resistance-type heating elements in electric space heating equipment shall be protected at not more than 60 amperes. Equipment rated more than 48 amperes and employing such elements shall have the heating elements subdivided, and each subdivided load shall not exceed 48 amperes. Where a subdivided load is less than 48 amperes the rating of the supplementary overcurrent protective device shall comply with Section 424-3(b).

*Exception: As provided in Section 424-72(a).*

**(c) Overcurrent Protective Devices.** The supplementary overcurrent protective devices for the subdivided loads specified in (b) above shall be: (1) factory installed within or on the heater enclosure or supplied for use with the heater as a separate assembly by the heater manufacturer; (2) accessible, but shall not be required to be readily accessible; and (3) suitable for branch-circuit protection.

(FPN): See Section 240-10.

Where cartridge fuses are used to provide this overcurrent protection, a single disconnecting means shall be permitted to be used for the several subdivided loads.

(FPN): See Section 240-40.

**(d) Branch-Circuit Conductors.** The conductors supplying the supplementary overcurrent protective devices shall be considered branch-circuit conductors.

*Exception: For heaters rated 50 kW or more, the conductors supplying the supplementary overcurrent protective devices specified in (c) above shall be permitted to be sized at not less than 100 percent of the nameplate rating of the heater provided all of the following conditions are met:*

- a. The heater is marked with a minimum conductor size; and*
- b. The conductors are not smaller than the marked minimum size; and*
- c. A temperature-actuated device controls the cyclic operation of the equipment.*

**(e) Conductors for Subdivided Loads.** Field-wired conductors between the heater and the supplementary overcurrent protective devices shall be sized at not less than 125 percent of the load served. The supplementary overcurrent protective devices specified in (c) shall protect these conductors in accordance with Section 240-3.



*Exception: For heaters rated 50 kW or more, the ampacity of field-wired conductors between the heater and the supplementary overcurrent protective devices shall be permitted to be not less than 100 percent of the load of their respective subdivided circuits provided all of the following conditions are met:*

- a. The heater is marked with a minimum conductor size; and*
- b. The conductors are not smaller than the marked minimum size; and*
- c. A temperature-activated device controls the cyclic operation of the equipment.*

#### **D. Marking of Heating Equipment**

##### **424-28. Nameplate.**

**(a) Marking Required.** Each unit of fixed electric space heating equipment shall be provided with a nameplate giving the identifying name and the normal rating in volts and watts, or in volts and amperes.

Electric space heating equipment intended for use on alternating current only or direct current only shall be marked to so indicate. The marking of equipment consisting of motors over  $\frac{1}{8}$  horsepower and other loads shall specify the rating of the motor in volts, amperes, and frequency, and the heating load in volts and watts, or in volts and amperes.

**(b) Location.** This nameplate shall be located so as to be visible or easily accessible after installation.

**424-29. Marking of Heating Elements.** All heating elements that are replaceable in the field and are a part of an electric heater shall be legibly marked with the ratings in volts and watts, or in volts and amperes.

#### **E. Electric Space Heating Cables**

**424-34. Heating Cable Construction.** Heating cables shall be furnished complete with factory-assembled nonheating leads at least 7 feet (2.13 m) in length.

**424-35. Marking of Heating Cables.** Each unit shall be marked with the identifying name or identification symbol, catalog number, ratings in volts and watts, or in volts and amperes.

Each unit length of heating cable shall have a permanent legible marking on each nonheating lead located within 3 inches (76 mm) of the terminal end. The lead wire shall have the following color identification to indicate the circuit voltage on which it is to be used: 120-volt nominal, yellow; 208-volt nominal, blue; 240-volt nominal, red; and 277-volt nominal, brown.

**424-36. Clearances of Wiring in Ceilings.** Wiring located above heated ceilings shall be spaced not less than 2 inches (50.8 mm) above the heated ceiling and shall be considered as operating at an ambient of 50°C. The ampacity of conductors shall be computed on the basis of the correction factors given in Tables 310-16 through 310-31.

*Exception: Wiring above heated ceilings and located above thermal insulation having a minimum thickness of 2 inches (50.8 mm) shall not require correction for temperature.*

**424-37. Location of Branch-Circuit and Feeder Wiring in Exterior Walls.** Wiring methods shall comply with Article 300 and Section 310-10.

**424-38. Area Restrictions.**

(a) **Shall Not Extend Beyond the Room or Area.** Heating cables shall not extend beyond the room or area in which they originate.

(b) **Uses Prohibited.** Cables shall not be installed in closets, over walls or partitions that extend to the ceiling, or over cabinets whose clearance from the ceiling is less than the minimum horizontal dimension of the cabinet to the nearest cabinet edge that is open to the room or area.

*Exception: Isolated single runs of cable shall be permitted to pass over partitions where they are embedded.*

(c) **In Closet Ceilings as Low Temperature Heat Sources to Control Relative Humidity.** This provision shall not prevent the use of cable in closet ceilings as low temperature heat sources to control relative humidity, provided they are used only in those portions of the ceiling that are unobstructed to the floor by shelves or other permanent fixtures.

**424-39. Clearance from Other Objects and Openings.** Heating elements of cables shall be separated at least 8 inches (203 mm) from the edge of outlet boxes and junction boxes that are to be used for mounting surface lighting fixtures. A clearance of not less than 2 inches (50.8 mm) shall be provided from recessed fixtures and their trims, ventilating openings, and other such openings in room-surfaces. Sufficient area shall be provided to assure that no heating cable will be covered by any surface-mounted units.

**424-40. Splices.** Embedded cables shall be spliced only where necessary and only by approved means, and in no case shall the length of the heating cable be altered.

**424-41. Installation of Heating Cables on Dry Board, in Plaster and on Concrete Ceilings.**

(a) **Shall Not Be Installed in Walls.** Cables shall not be installed in walls.

*Exception: Isolated single runs of cable shall be permitted to run down a vertical surface to reach a dropped ceiling.*

(b) **Adjacent Runs.** Adjacent runs of cable not exceeding  $2\frac{3}{4}$  watts per foot shall be installed not less than  $1\frac{1}{2}$  inches (38 mm) on centers.

(c) **Surfaces to Be Applied.** Heating cables shall be applied only to gypsum board, plaster lath or other fire-resistant material. With metal lath or other electrically conductive surfaces, a coat of plaster shall be applied to completely separate the metal lath or conductive surface from the cable.

(FPN): See also (f) below.

(d) **Splices.** All heating cables, the splice between the heating cable and nonheating leads, and 3-inch (76-mm) minimum of the nonheating lead at the splice shall be embedded in plaster or dry board in the same manner as the heating cable.

(e) **Ceiling Surface.** The entire ceiling surface shall have a finish of thermally noninsulating sand plaster having a nominal thickness of  $\frac{1}{2}$  inch (12.7 mm), or other noninsulating material identified as suitable for this use and applied according to specified thickness and directions.

(f) **Secured.** Cables shall be secured at intervals not exceeding 16 inches (406 mm) by means of approved stapling, tape, plaster, nonmetallic spreaders, or other approved means. Staples or metal fasteners that straddle the cable shall not be used with metal lath or other electrically conductive surfaces.

*Exception: Cables identified to be secured at intervals not to exceed 6 feet (1.83 m).*

(g) **Dry Board Installations.** In dry board installations, the entire ceiling below the heating cable shall be covered with gypsum board not exceeding ½ inch (12.7 mm) thickness. The void between the upper layer of gypsum board, plaster lath, or other fire-resistant material and the surface layer of gypsum board shall be completely filled with thermally conductive nonshrinking plaster or other approved material or equivalent thermal conductivity.

(h) **Free from Contact with Conductive Surfaces.** Cables shall be kept free from contact with metal or other electrical conductive surfaces.

(i) **Joists.** In dry board applications, cable shall be installed parallel to the joist, leaving a clear space centered under the joist of 2½ inches (64 mm) (width) between centers of adjacent runs of cable. Surface layer of gypsum board shall be mounted so that the nails or other fasteners do not pierce the heating cable.

(j) **Crossing Joists.** Cables shall cross joists only at the ends of the room.

*Exception: Where the cable is required to cross joists elsewhere in order to satisfy the manufacturer's instructions that the installer avoid placing the cable too close to ceiling penetrations and light fixtures.*

**424-42. Finished Ceilings.** Finished ceilings shall not be covered with decorative panels or beams constructed of materials which have thermal insulating properties, such as wood, fiber, or plastic. Finished ceilings shall be permitted to be covered with paint, wallpaper, or other approved surface finishes.

#### **424-43. Installation of Nonheating Leads of Cables.**

(a) **Free Nonheating Leads.** Free nonheating leads of cables shall be installed in accordance with approved wiring methods from the junction box to a location within the ceiling. Such installations shall be permitted to be single conductors in approved raceways, single or multiconductor Type UF, Type NMC, Type MI, or other approved conductors.

(b) **Leads in Junction Box.** Not less than 6 inches (152 mm) of free nonheating lead shall be within the junction box. The marking of the leads shall be visible in the junction box.

(c) **Excess Leads.** Excess leads of heating cables shall not be cut but shall be secured to the underside of the ceiling and embedded in plaster or other approved material, leaving only a length sufficient to reach the junction box with not less than 6 inches (152 mm) of free lead within the box.

#### **424-44. Installation of Cables in Concrete or Poured Masonry Floors.**

(a) **Watts per Linear Foot.** Heating cables shall not exceed 16½ watts per linear foot (305 mm) of cable.

**(b) Spacing Between Adjacent Runs.** The spacing between adjacent runs of cable shall not be less than 1 inch (25.4 mm) on centers.

**(c) Secured in Place.** Cables shall be secured in place by nonmetallic frames or spreaders or other approved means while the concrete or other finish is applied.

Cables shall not be installed where they bridge expansion joints unless protected from expansion and contraction.

**(d) Spacings Between Heating Cable and Metal Embedded in the Floor.** Spacings shall be maintained between the heating cable and metal embedded in the floor.

*Exception: Grounded metal-clad cable shall be permitted to be in contact with metal embedded in the floor.*

**(e) Leads Protected.** Leads shall be protected where they leave the floor by rigid metal conduit, intermediate metal conduit, rigid nonmetallic conduit, electrical metallic tubing, or by other approved means.

**(f) Bushings or Approved Fittings.** Bushings or approved fittings shall be used where the leads emerge within the floor slab.

**424-45. Inspection and Tests.** Cable installations shall be made with due care to prevent damage to the cable assembly and shall be inspected and approved before cables are covered or concealed.

## F. Duct Heaters

**424-57. General.** Part F shall apply to any heater mounted in the air stream of a forced-air system where the air moving unit is not provided as an integral part of the equipment.

**424-58. Identification.** Heaters installed in an air duct shall be identified as suitable for the installation.

**424-59. Air Flow.** Means shall be provided to assure uniform and adequate air flow over the face of the heater in accordance with the manufacturer's instructions.

(FPN): Heaters installed within 4 feet (1.22 m) of the outlet of an air-moving device, heat pump, air conditioner, elbows, baffle plates, or other obstructions in duct work may require turning vanes, pressure plates, or other devices on the inlet side of the duct heater to assure an even distribution of air over the face of the heater.

**424-60. Elevated Inlet Temperature.** Duct heaters intended for use with elevated inlet air temperature shall be identified as suitable for use at the elevated temperatures.

**424-61. Installation of Duct Heaters with Heat Pumps and Air Conditioners.** Heat pumps and air conditioners having duct heaters closer than 4 feet (1.22 m) to the heat pump or air conditioner shall have both the duct heater and heat pump or air conditioner identified as suitable for such installation and so marked.

**424-62. Condensation.** Duct heaters used with air conditioners or other air-cooling equipment that may result in condensation of moisture shall be identified as suitable for use with air conditioners.

**424-63. Fan Circuit Interlock.** Means shall be provided to ensure that the fan circuit is energized when any heater circuit is energized. However, time- or temperature-controlled delay in energizing the fan motor shall be permitted.

**424-64. Limit Controls.** Each duct heater shall be provided with an approved, integral, automatic-reset temperature-limiting control or controllers to de-energize the circuit or circuits.

In addition, an integral independent supplementary control or controllers shall be provided in each duct heater that will disconnect a sufficient number of conductors to interrupt current flow. This device shall be manually resettable or replaceable.

**424-65. Location of Disconnecting Means.** Duct heater controller equipment shall be accessible with the disconnecting means installed at or within sight from the controller.

*Exception: As permitted by Section 424-19(a).*

**424-66. Installation.** Duct heaters shall be installed in accordance with the manufacturer's instructions in a manner so that operation will not create a hazard to persons or property. Furthermore, duct heaters shall be located with respect to building construction and other equipment so as to permit access to the heater. Sufficient clearance shall be maintained to permit replacement of controls and heating elements and for adjusting and cleaning of controls and other parts requiring such attention. See Section 110-16.

(FPN): For additional installation information, see Air Conditioning and Ventilating Systems, NFPA 90A-1985 (ANSI) and Warm Air Heating and Air Conditioning Systems, NFPA 90B-1984 (ANSI).

### G. Resistance-type Boilers

**424-70. Scope.** The provisions in Part G of this article shall apply to boilers employing resistance-type heating elements. Electrode-type boilers shall not be considered as employing resistance-type heating elements. See Part H of this article.

**424-71. Identification.** Resistance-type boilers shall be identified as suitable for the installation.

**424-72. Overcurrent Protection.**

(a) **Boiler Employing Resistance-type Immersion Heating Elements in an ASME Rated and Stamped Vessel.** A boiler employing resistance-type immersion heating elements contained in an ASME rated and stamped vessel shall have the heating elements protected at not more than 150 amperes. Such a boiler rated more than 120 amperes shall have the heating elements subdivided into loads not exceeding 120 amperes.

Where a subdivided load is less than 120 amperes, the rating of the overcurrent protective device shall comply with Section 424-3(b).

(b) **Boiler Employing Resistance-type Heating Elements Rated More than 48 Amperes and Not Contained in an ASME Rated and Stamped Vessel.** A boiler employing resistance-type heating elements not contained in an ASME rated and stamped vessel shall have the heating elements protected at not

more than 60 amperes. Such a boiler rated more than 48 amperes shall have the heating elements subdivided into loads not exceeding 48 amperes.

Where a subdivided load is less than 48 amperes, the rating of the overcurrent protective device shall comply with Section 424-3(b).

**(c) Supplementary Overcurrent Protective Devices.** The supplementary overcurrent protective devices for the subdivided loads as required by Section 424-72(a) and (b) shall be: (1) factory installed within or on the boiler enclosure or provided as a separate assembly by the boiler manufacturer; and (2) accessible, but need not be readily accessible; and (3) suitable for branch-circuit protection.

Where cartridge fuses are used to provide this overcurrent protection, a single disconnecting means shall be permitted for the several subdivided circuits. See Section 240-40.

**(d) Conductors Supplying Supplementary Overcurrent Protective Devices.** The conductors supplying these supplementary overcurrent protective devices shall be considered branch-circuit conductors.

*Exception: Where the heaters are rated 50 kW or more, the conductors supplying the overcurrent protective device specified in (c) above shall be permitted to be sized at not less than 100 percent of the nameplate rating of the heater provided all of the following conditions are met:*

- a. The heater is marked with a minimum conductor size; and*
- b. The conductors are not smaller than the marked minimum size; and*
- c. A temperature or pressure-actuated device controls the cyclic operation of the equipment.*

**(e) Conductors for Subdivided Loads.** Field-wired conductors between the heater and the supplementary overcurrent protective devices shall be sized at not less than 125 percent of the load served. The supplementary overcurrent protective devices specified in (c) shall protect these conductors in accordance with Section 240-3.

*Exception: For heaters rated 50 kW or more, the ampacity of field-wired conductors between the heater and the supplementary overcurrent protective devices shall be permitted to be not less than 100 percent of the load of their respective subdivided circuits provided all of the following conditions are met:*

- a. The heater is marked with a minimum conductor size; and*
- b. The conductors are not smaller than the marked minimum size; and*
- c. A temperature-activated device controls the cyclic operation of the equipment.*

**424-73. Over-Temperature Limit Control.** Each boiler designed, so that in normal operation there is no change in state of the heat transfer medium, shall be equipped with a temperature sensitive limiting means. It shall be installed to limit maximum liquid temperature and shall directly or indirectly disconnect all ungrounded conductors to the heating elements. Such means shall be in addition to a temperature regulating system and other devices protecting the tank against excessive pressure.

**424-74. Over-Pressure Limit Control.** Each boiler designed, so that in normal operation there is a change in state of the heat transfer medium from liquid to vapor, shall be equipped with a pressure sensitive limiting means. It

shall be installed to limit maximum pressure and shall directly or indirectly disconnect all ungrounded conductors to the heating elements. Such means shall be in addition to a pressure regulating system and other devices protecting the tank against excessive pressure.

**424-75. Grounding.** All noncurrent-carrying metal parts shall be grounded in accordance with Article 250. Means for connection of equipment grounding conductor(s) sized in accordance with Table 250-95 shall be provided.

#### H. Electrode-type Boilers

**424-80. Scope.** The provisions in Part H of this article shall apply to boilers for operation at 600 volts, nominal, or less, in which heat is generated by the passage of current between electrodes through the liquid being heated.

**424-81. Identification.** Electrode-type boilers shall be identified as suitable for the installation.

**424-82. Branch-Circuit Requirements.** The size of branch-circuit conductors and overcurrent protective devices shall be calculated on the basis of 125 percent of the total load (motors not included). A contactor, relay or other device, approved for continuous operation at 100 percent of its rating, shall be permitted to supply its full-rated load. See Section 210-22(c), Exception No. 2. The provisions of this section shall not apply to conductors that form an integral part of an approved boiler.

*Exception: For an electrode boiler rated 50 kW or more, the conductors supplying the boiler electrode(s) shall be permitted to be sized at not less than 100 percent of the nameplate rating of the electrode boiler provided all the following conditions are met:*

- a. The electrode boiler is marked with a minimum conductor size; and*
- b. The conductors are not smaller than the marked minimum size; and*
- c. A temperature or pressure-actuated device controls the cyclic operation of the equipment.*

**424-83. Over-Temperature Limit Control.** Each boiler designed, so that in normal operation there is no change in state of the heat transfer medium, shall be equipped with a temperature sensitive limiting means. It shall be installed to limit maximum liquid temperature and shall directly or indirectly interrupt all current flow through the electrodes. Such means shall be in addition to the temperature regulating system and other devices protecting the tank against excessive pressure.

**424-84. Over-Pressure Limit Control.** Each boiler designed, so that in normal operation there is a change in state of the heat transfer medium from liquid to vapor, shall be equipped with a pressure sensitive limiting means. It shall be installed to limit maximum pressure and shall directly or indirectly interrupt all current flow through the electrodes. Such means shall be in addition to a pressure regulating system and other devices protecting the tank against excessive pressure.

**424-85. Grounding.** For those boilers designed such that fault currents do not pass through the pressure vessel and the pressure vessel is electrically isolated from the electrodes, all exposed noncurrent-carrying metal parts

including the pressure vessel, supply, and return connecting piping shall be grounded in accordance with Article 250.

For all other designs the pressure vessel containing the electrodes shall be isolated and electrically insulated from ground.

**424-86. Markings.** All electrode-type boilers shall be marked to show: (1) the manufacturer's name; (2) the normal rating in volts, amperes, and kilowatts; (3) the electrical supply required specifying frequency, number of phases, and number of wires; (4) the marking: "Electrode-type Boiler"; (5) a warning marking — "ALL POWER SUPPLIES SHALL BE DISCONNECTED BEFORE SERVICING INCLUDING SERVICING THE PRESSURE VESSEL."

The nameplate shall be located so as to be visible after installation.

#### J. Electric Radiant Heating Panels and Heating Panel Sets

**424-90. Scope.** The provisions of Part J of this article shall apply to radiant heating panels and heating panel sets.

##### 424-91. Definitions.

(a) **Heating Panel.** A heating panel is a complete assembly provided with a junction box or a length of flexible conduit for connection to a branch circuit.

(b) **Heating Panel Set.** A heating panel set is a rigid or nonrigid assembly provided with nonheating leads or a terminal junction assembly identified as being suitable for connection to a wiring system.

##### 424-92. Markings.

(1) Markings shall be permanent and in a location that is visible prior to application of panel finish.

(2) Each unit shall be identified as suitable for the installation.

(3) Each unit shall be marked with the identifying name or identification symbol, catalog number, rating in volts and watts, or in volts and amperes.

(4) The manufacturers of heating panels or heating panel sets shall provide marking labels which indicate that the space heating installation incorporates heating panels or heating panel sets and instructions that the labels shall be affixed to the panelboards to identify which branch circuits supply the circuits to those space heating installations.

*Exception: Heating panels and heating panel set installations that are visible and distinguishable after installation shall not be required to have labels provided.*

##### 424-93. Installation.

###### (a) General.

(1) Heating panels and heating panel sets shall be installed in accordance with the manufacturer's instructions.

(2) The heating portion shall not:

a. Be installed in or behind surfaces where subject to physical damage.

b. Be run through or above walls, partitions, cupboards or similar portions of structures that extend to the ceiling.



c. Be run in or through thermal insulation, but shall be permitted to be in contact with the surface of thermal insulation.

(3) Edges of panels and panel sets shall be separated by not less than 8 inches (203 mm) from the edges of any outlet boxes and junction boxes that are to be used for mounting surface lighting fixtures. A clearance of not less than 2 inches (50.8 mm) shall be provided from recessed fixtures and their trims, ventilating openings and other such openings in room surfaces. Sufficient area shall be provided to assure that no heating panel or heating panel set is to be covered by any surface-mounted units.

*Exception: Heating panels and panel sets listed and marked for lesser clearances shall be permitted to be installed at the marked clearances.*

(4) After the heating panels or heating panel sets are installed and inspected, it shall be permitted to install a surface which has been identified by the manufacturer's instructions as being suitable for the installation. The surface shall be secured so that the nails or other fastenings do not pierce the heating panels or heating panel sets.

(5) Surfaces permitted by Section 424-93(a)(4) shall be permitted to be covered with paint, wallpaper or other approved surfaces identified in the manufacturer's instructions as being suitable.

**(b) Heating Panel Sets.**

(1) Heating panel sets shall be permitted to be secured to the lower face of joists or mounted in between joists, headers or nailing strips.

(2) Heating panel sets shall be installed parallel to joists or nailing strips.

(3) Nailing or stapling of heating panel sets shall be done only through the unheated portions provided for this purpose. Heating panel sets shall not be cut through or nailed through any point closer than  $\frac{1}{4}$  inch (6.35 mm) to the element. Nails, staples or other fasteners shall not be used where they penetrate current-carrying parts.

(4) Heating panel sets shall be installed as complete units unless identified as suitable for field cutting in an approved manner.

**424-94. Clearances of Wiring in Ceilings.** Wiring located above heated ceilings shall be spaced not less than 2 inches (50.3 mm) above the heated ceiling and shall be considered as operating at an ambient of 50°C (122°F). The ampacity shall be computed on the basis of the correction factors given in Tables 310-16 through 310-31.

*Exception: Wiring above heated ceilings and located above thermal insulations having a minimum thickness of 2 inches (50.8 mm) shall not require correction for temperature.*

**424-95. Location of Branch-Circuit and Feeder Wiring in Walls.**

(a) **Exterior Walls.** Wiring methods shall comply with Article 300 and Section 310-10.

(b) **Interior Walls.** Any wiring behind heating panels or heating panel sets located in interior walls or partitions shall be considered as operating at an ambient of 40°C (104°F) and the ampacity shall be computed on the basis of the correction factors given in Tables 310-16 through 310-31.

**424-96. Connection to Branch-Circuit Conductors.**

(a) **General.** Heating panels or heating panel sets assembled together in the field to form a heating installation in one room or area shall be connected in accordance with the manufacturer's instructions.

(b) **Heating Panels.** Heating panels shall be connected to branch-circuit wiring by an approved wiring method.

(c) **Heating Panel Sets.**

(1) Heating panel sets shall be connected to branch-circuit wiring by a method identified as being suitable for the purpose.

(2) A heating panel set provided with terminal junction assembly shall be permitted to have the nonheating leads attached at the time of installation in accordance with the manufacturer's instructions.

**424-97. Nonheating Leads.** Excess nonheating leads of heating panels or heating panel sets shall be permitted to be cut to the required length. They shall meet the installation requirements of the wiring method employed in accordance with Section 424-96. Nonheating leads shall be an integral part of a heating panel and a heating panel set and shall not be subjected to the ampacity requirements of Section 424-3(b) for branch circuits.

**424-98. Installation in Concrete or Poured Masonry.**

(a) **Maximum Heated Area.** Heating panels or heating panel sets shall not exceed 33 watts per square foot (0.093 sq m) of heated area.

(b) **Secured in Place and Identified as Suitable.** Heating panels or heating panel sets shall be secured in place by means specified in the manufacturer's instructions and identified as suitable for the installation.

(c) **Expansion Joints.** Heating panels or heating panel sets shall not be installed where they bridge expansion joints unless protected from expansion and contraction.

(d) **Spacings.** Spacings shall be maintained between heating panels or heating panel sets and metal embedded in the floor.

*Exception: Grounded metal-clad heating panels shall be permitted to be in contact with metal embedded in the floor.*

(e) **Protection of Leads.** Leads shall be protected where they leave the floor by rigid metal conduit, intermediate metal conduit, rigid nonmetallic conduit, electrical metallic tubing or by other approved means.

(f) **Bushings or Fittings Required.** Bushings or approved fittings shall be used where the leads emerge within the floor slabs.

**424-99. Installation Under Floor Covering.**

(a) **Identification.** Heating panels or heating panel sets for installation under floor covering shall be identified as suitable for installation under floor covering.

(b) **Maximum Heated Area.** Heating panels or panel sets, installed under floor covering, shall not exceed 15 watts per square foot (0.093 m<sup>2</sup>) of heated area.

(c) **Installation.** Listed heating panels or panel sets, if installed under floor covering, shall be installed on floor surfaces which are smooth and flat in accordance with the manufacturer's instructions and shall also comply with the following:

(1) **Expansion Joints.** Heating panels or heating panel sets shall not be installed where they bridge expansion joints unless protected from expansion and contraction.

(2) **Connection to Conductors.** Heating panels and heating panel sets shall be connected to branch-circuit and supply wiring by wiring methods recognized in Chapter 3.

(3) **Anchoring.** Heating panels and heating panel sets shall be firmly anchored to the floor using an adhesive or anchoring system identified for this use.

(4) **Coverings.** After heating panels or heating panel sets are installed and inspected, they shall be permitted to be covered by a floor covering which has been identified by the manufacturer as being suitable for the installation. The covering shall be secured to the heating panel or heating panel sets with release-type adhesives.

(5) **Fault Protection.** A device to open all ungrounded conductors supplying the heating panels or heating panel sets, provided by the manufacturer, shall function when a low or high resistance line to line, line to grounded conductor or line to ground fault occurs such as the result of a penetration of the element/element assembly.

(FPN): An integral grounding shield may be required to provide this protection.

## ARTICLE 426 — FIXED OUTDOOR ELECTRIC DE-ICING AND SNOW-MELTING EQUIPMENT

### A. General

**426-1. Scope.** The requirements of this article shall apply to electrically energized heating systems and the installation of these systems.

(a) **Embedded.** Embedded in driveways, walks, steps, and other areas.

(b) **Exposed.** Exposed on drainage systems, bridge structures, roofs, and other structures.

**426-2. Definitions.** For the purpose of this article:

**Heating System.** A complete system consisting of components such as heating elements, fastening devices, nonheating circuit wiring, leads, temperature controllers, safety signs, junction boxes, raceways, and fittings.

**Resistance Heating Element.** A specific separate element to generate heat which is embedded in or fastened to the surface to be heated.

(FPN): Tubular heaters, strip heaters, heating cable, heating tape, and heating panels are examples of resistance heaters.

**Impedance Heating System.** A system in which heat is generated in a pipe or rod, or combination of pipes and rods, by causing current to flow through the pipe or rod by direct connection to an ac voltage source from a dual-winding transformer. The pipe or rod shall be permitted to be embedded in the surface to be heated, or constitute the exposed components to be heated.

**Skin Effect Heating System.** A system in which heat is generated on the inner surface of a ferromagnetic envelope embedded in or fastened to the surface to be heated.

(FPN): Typically, an electrically insulated conductor is routed through and connected to the envelope at the other end. The envelope and the electrically insulated conductor are connected to an ac voltage source from a dual-winding transformer.

**426-3. Application of Other Articles.** All requirements of this Code shall apply except as specifically amended in this article. Cord- and plug-connected fixed outdoor electric de-icing and snow-melting equipment intended for specific use and identified as suitable for this use shall be installed according to Article 422. Fixed outdoor electric de-icing and snow-melting equipment for use in hazardous (classified) locations shall comply with Articles 500 through 516.

**426-4. Branch-Circuit Sizing.** The ampacity of branch-circuit conductors and the rating or setting of overcurrent protective devices supplying fixed outdoor electric de-icing and snow-melting equipment shall not be less than 125 percent of the total load of the heaters. The rating or setting of overcurrent protective devices shall be permitted in accordance with Section 240-3, Exception No. 1.

## B. Installation

**426-10. General.** Equipment for outdoor electric de-icing and snow melting shall be identified as being suitable for:

- (1) The chemical, thermal, and physical environment, and
- (2) Installation in accordance with the manufacturer's drawings and instructions.

**426-11. Use.** Electrical heating equipment shall be installed in such a manner as to be afforded protection from physical damage.

**426-12. Thermal Protection.** External surfaces of outdoor electric de-icing and snow-melting equipment which operate at temperatures exceeding 60°C (140°F) shall be physically guarded, isolated, or thermally insulated to protect against contact by personnel in the area.

**426-13. Identification.** The presence of outdoor electric de-icing and snow-melting equipment shall be evident by the posting of appropriate caution signs or markings where clearly visible.

**426-14. Special Permission.** Fixed outdoor de-icing and snow-melting equipment employing methods of construction or installation other than covered by this article shall be permitted only by special permission.

## C. Resistance Heating Elements

**426-20. Embedded De-Icing and Snow-Melting Equipment.**

- (a) **Watt Density.** Panels or units shall not exceed 120 watts per square foot (0.093 sq m) of heated area.

(b) **Spacing.** The spacing between adjacent cable runs is dependent upon the rating of the cable, and shall be not less than 1 inch (25.4 mm) on centers.

(c) **Cover.** Units, panels, or cables shall be installed:

(1) On a substantial asphalt or masonry base at least 2 inches (50.8 mm) thick and have at least 1½ inches (38 mm) of asphalt or masonry applied over the units, panels, or cables; or

(2) They shall be permitted to be installed over other approved bases and embedded within 3½ inches (89 mm) of masonry or asphalt but not less than 1½ inches (38 mm) from the top surface; or

(3) Equipment that has been specially investigated for other forms of installation shall be installed only in the manner for which it has been investigated.

(d) **Secured.** Cables, units, and panels shall be secured in place by frames or spreaders or other approved means while the masonry or asphalt finish is applied.

(e) **Expansion and Contraction.** Cables, units, and panels shall not be installed where they bridge expansion joints unless adequately protected from expansion and contraction.

#### 426-21. Exposed De-Icing and Snow-Melting Equipment.

(a) **Secured.** Heating element assemblies shall be secured to the surface being heated by approved means.

(b) **Overtemperature.** Where the heating element is not in direct contact with the surface being heated, the design of the heater assembly shall be such that its temperature limitations shall not be exceeded.

(c) **Expansion and Contraction.** Heating elements and assemblies shall not be installed where they bridge expansion joints unless provision is made for expansion and contraction.

(d) **Flexural Capability.** Where installed on flexible structures, the heating elements and assemblies shall have a flexural capability compatible with the structure.

#### 426-22. Installation of Nonheating Leads for Embedded Equipment.

(a) **Grounding Sheath or Braid.** Nonheating leads having a grounding sheath or braid shall be permitted to be embedded in the masonry or asphalt in the same manner as the heating cable without additional physical protection.

(b) **Raceways.** All but 1 to 6 inches (25.4 to 152 mm) of nonheating leads of Type TW and other approved types not having a grounding sheath shall be enclosed in a rigid conduit, electrical metallic tubing, intermediate metal conduit, or other raceways within asphalt or masonry; and the distance from the factory splice to raceway shall be not less than 1 inch (25.4 mm) or more than 6 inches (152 mm).

(c) **Bushings.** Insulating bushings shall be used in the asphalt or masonry where leads enter conduit or tubing.

(d) **Expansion and Contraction.** Leads shall be protected in expansion joints and where they emerge from masonry or asphalt by rigid conduit, electrical metallic tubing, intermediate metal conduit, other raceways, or other approved means.

(e) **Leads in Junction Boxes.** Not less than 6 inches (152 mm) of free nonheating lead shall be within the junction box.

#### **426-23. Installation of Nonheating Leads for Exposed Equipment.**

(a) **Nonheating Leads.** Power supply nonheating leads (cold leads) for resistance elements shall be suitable for the temperature encountered. Preassembled nonheating leads on approved heaters shall be permitted to be shortened if the markings specified in Section 426-25 are retained. Not less than 6 inches (152 mm) of nonheating leads shall be provided within the junction box.

(b) **Protection.** Nonheating power supply leads shall be enclosed in a rigid conduit, intermediate metal conduit, electrical metallic tubing, or other approved means.

#### **426-24. Electrical Connection.**

(a) **Heating Element Connections.** Electrical connections, other than factory connections of heating elements to nonheating elements embedded in masonry or asphalt or on exposed surfaces, shall be made with insulated connectors identified for the use.

(b) **Circuit Connections.** Splices and terminations at the end of the nonheating leads, other than the heating element end, shall be installed in a box or fitting in accordance with Sections 110-14 and 300-15.

**426-25. Marking.** Each factory-assembled heating unit shall be legibly marked within 3 inches (76 mm) of each end of the nonheating leads with the permanent identification symbol, catalog number, and ratings in volts and watts, or in volts and amperes.

**426-26. Corrosion Protection.** Ferrous and nonferrous metal raceways, cable armor, cable sheaths, boxes, fittings, supports, and support hardware shall be permitted to be installed in concrete or in direct contact with the earth, or in areas subject to severe corrosive influences, when made of material suitable for the condition, or when provided with corrosion protection identified as suitable for the condition.

#### **426-27. Grounding.**

(a) **Metal Parts.** Exposed noncurrent-carrying metal parts of equipment likely to become energized shall be grounded as required in Article 250.

(b) **Grounding Braid or Sheath.** Grounding means, such as copper braid, metal sheath, or other approved means, shall be provided as part of the heated section of the cable, panel, or unit.

(c) **Bonding and Grounding.** All noncurrent-carrying metal parts that are likely to become energized shall be bonded together and connected to an equipment grounding conductor sized in accordance with Table 250-95, extending to the distribution panelboard.

### **D. Impedance Heating**

**426-30. Personnel Protection.** Exposed elements of impedance heating systems shall be physically guarded, isolated, or thermally insulated with weatherproof jacket to protect against contact by personnel in the area.

**426-31. Voltage Limitations.** The impedance heating elements shall not operate at a voltage greater than 30 volts ac.

*Exception: The voltage shall be permitted to be greater than 30 volts, but not more than 80 volts, if a ground-fault circuit-interrupter for personnel protection is provided.*

**426-32. Isolation Transformer.** A dual-winding transformer with a grounded shield between the primary and secondary windings shall be used to isolate the distribution system from the heating system.

**426-33. Induced Currents.** All current-carrying components shall be installed in accordance with Section 300-20.

**426-34. Grounding.** An impedance heating system that is operating at a voltage greater than 30, but not more than 80, shall be grounded at designated point(s).

### E. Skin Effect Heating

**426-40. Conductor Ampacity.** The ampacity of the electrically insulated conductor inside the ferromagnetic envelope shall be permitted to exceed the values shown in Article 310, provided it is identified as suitable for this use.

**426-41. Pull Boxes.** Where pull boxes are used they shall be accessible without excavation by location in suitable vaults or above grade. Outdoor pull boxes shall be of watertight construction.

**426-42. Single Conductor in Enclosure.** The provisions of Section 300-20 shall not apply to the installation of a single conductor in a ferromagnetic envelope (metal enclosure).

**426-43. Corrosion Protection.** Ferromagnetic envelopes, ferrous or nonferrous metal raceways, boxes, fittings, supports, and support hardware shall be permitted to be installed in concrete or in direct contact with the earth, or in areas subjected to severe corrosive influences, where made of material suitable for the condition, or where provided with corrosion protection identified as suitable for the condition. Corrosion protection shall maintain the original wall thickness of the ferromagnetic envelope.

**426-44. Grounding.** The ferromagnetic envelope shall be grounded at both ends; and, in addition, it shall be permitted to be grounded at intermediate points as required by its design.

The provisions of Section 250-26 shall not apply to the installation of skin effect heating systems.

(FPN): See Section 250-26(d).

### F. Control and Protection

**426-50. Disconnecting Means.**

(a) **Disconnection.** All fixed outdoor de-icing and snow-melting equipment shall be provided with a means for disconnection from all ungrounded conductors. Where readily accessible to the user of the equipment, the branch-circuit switch or circuit breaker shall be permitted to serve as the

disconnecting means. Switches used as the disconnecting means shall be of the indicating type.

(b) **Cord- and Plug-Connected Equipment.** The factory-installed attachment plug of cord- and plug-connected equipment rated 20 amperes or less and 150 volts or less to ground shall be permitted to be the disconnecting means.

#### **426-51. Controllers.**

(a) **Temperature Controller with "Off" Position.** Temperature controlled switching devices which indicate an "off" position and which interrupt line current shall open all ungrounded conductors when the control device is in the "off" position. These devices shall not be permitted to serve as the disconnecting means unless provided with a positive lockout in the "off" position.

(b) **Temperature Controller Without "Off" Position.** Temperature controlled switching devices which do not have an "off" position shall not be required to open all ungrounded conductors and shall not be permitted to serve as the disconnecting means.

(c) **Remote Temperature Controller.** Remote controlled temperature actuated devices shall not be required to meet the requirements of Section 426-51(a). These devices shall not be permitted to serve as the disconnecting means.

(d) **Combined Switching Devices.** Switching devices consisting of combined temperature actuated devices and manually controlled switches which serve both as the controller and the disconnecting means shall comply with all of the following conditions:

- (1) Open all ungrounded conductors when manually placed in the "off" position; and
- (2) Be so designed that the circuit cannot be energized automatically if the device has been manually placed in the "off" position; and
- (3) Be provided with a positive lockout in the "off" position.

**426-52. Overcurrent Protection.** Fixed outdoor electric de-icing and snow-melting equipment shall be permitted to be protected against overcurrent where supplied by a branch circuit as specified in Section 426-4.

## **ARTICLE 427 — FIXED ELECTRIC HEATING EQUIPMENT FOR PIPELINES AND VESSELS**

### **A. General**

**427-1. Scope.** The requirements of this article shall apply to electrically energized heating systems and the installation of these systems used with pipelines and/or vessels.

**427-2. Definitions.** For the purpose of this article:

**Pipeline.** A length of pipe including pumps, valves, flanges, control devices, strainers and/or similar equipment for conveying fluids.



**Vessel.** A container such as a barrel, drum, or tank for holding fluids or other material.

**Integrated Heating System.** A complete system consisting of components such as pipelines, vessels, heating elements, heat transfer medium, thermal insulation, moisture barrier, nonheating leads, temperature controllers, safety signs, junction boxes, raceways, and fittings.

**Resistance Heating Element.** A specific separate element to generate heat which is applied to the pipeline or vessel externally or internally.

(FPN): Tubular heaters, strip heaters, heating cable, heating tape, heating blankets, and immersion heaters are examples of resistance heaters.

**Impedance Heating System.** A system in which heat is generated in a pipeline or vessel wall by causing current to flow through the pipeline or vessel wall by direct connection to an ac voltage source from a dual-winding transformer.

**Induction Heating System.** A system in which heat is generated in a pipeline or vessel wall by inducing current and hysteresis effect in the pipeline or vessel wall from an external isolated ac field source.

**Skin Effect Heating System.** A system in which heat is generated on the inner surface of a ferromagnetic envelope attached to a pipeline and/or vessel.

(FPN): Typically, an electrically insulated conductor is routed through and connected to the envelope at the other end. The envelope and the electrically insulated conductor are connected to an ac voltage source from a dual-winding transformer.

**427-3. Application of Other Articles.** All requirements of this Code shall apply except as specifically amended in this article. Cord-connected pipe heating assemblies intended for specific use and identified as suitable for this use shall be installed according to Article 422. Fixed electric pipeline and vessel heating equipment for use in hazardous (classified) locations shall comply with Articles 500 through 516.

**427-4. Branch-Circuit Sizing.** The ampacity of branch-circuit conductors and the rating or setting of overcurrent protective devices supplying fixed electric heating equipment for pipelines and vessels shall be not less than 125 percent of the total load of the heaters. The rating or setting of overcurrent protective devices shall be permitted in accordance with Section 240-3, Exception No. 1.

## B. Installation

**427-10. General.** Equipment for pipeline and vessel electrical heating shall be identified as being suitable for: (1) the chemical, thermal and physical environment; and (2) installation in accordance with the manufacturer's drawings and instructions.

**427-11. Use.** Electrical heating equipment shall be installed in such a manner as to be afforded protection from physical damage.

**427-12. Thermal Protection.** External surfaces of pipeline and vessel heating equipment which operate at temperatures exceeding 60°C (140°F) shall be

physically guarded, isolated, or thermally insulated to protect against contact by personnel in the area.

**427-13. Identification.** The presence of electrically heated pipelines and/or vessels shall be evident by the posting of appropriate caution signs or markings at frequent intervals along the pipeline or vessel.

### C. Resistance Heating Elements

**427-14. Secured.** Heating element assemblies shall be secured to the surface being heated by means other than the thermal insulation.

**427-15. Not in Direct Contact.** Where the heating element is not in direct contact with the pipeline or vessel being heated, means shall be provided to prevent overtemperature of the heating element unless the design of the heater assembly is such that its temperature limitations will not be exceeded.

**427-16. Expansion and Contraction.** Heating elements and assemblies shall not be installed where they bridge expansion joints unless provisions are made for expansion and contraction.

**427-17. Flexural Capability.** Where installed on flexible pipelines, the heating elements and assemblies shall have a flexural capability compatible with the pipeline.

**427-18. Power Supply Leads.**

(a) **Nonheating Leads.** Power supply nonheating leads (cold leads) for resistance elements shall be suitable for the temperature encountered. Preassembled nonheating leads on approved heaters shall be permitted to be shortened if the markings specified in Section 427-20 are retained. Not less than 6 inches (152 mm) of nonheating leads shall be provided within the junction box.

(b) **Power Supply Leads Protection.** Nonheating power supply leads shall be protected where they emerge from electrically heated pipeline or vessel heating units by rigid metal conduit, intermediate metal conduit, electrical metallic tubing, or other raceways identified as suitable for the application.

(c) **Interconnecting Leads.** Interconnecting nonheating leads connecting portions of the heating system shall be permitted to be covered by thermal insulation in the same manner as the heaters.

**427-19. Electrical Connections.**

(a) **Nonheating Interconnections.** Nonheating interconnections, where required under thermal insulation, shall be made with insulated connectors identified as suitable for this use.

(b) **Circuit Connections.** Splices and terminations outside the thermal insulation shall be installed in a box or fitting in accordance with Sections 110-14 and 300-15.

**427-20. Marking.** Each factory-assembled heating unit shall be legibly marked within 3 inches (76 mm) of each end of the nonheating leads with the permanent identification symbol, catalog number, and ratings in volts and watts, or in volts and amperes.

**427-21. Grounding.** Exposed noncurrent-carrying metal parts of electric heating equipment which are likely to become energized shall be grounded as required in Article 250.

**427-22. Equipment Protection.** Ground-fault protection of equipment shall be provided for branch circuits supplying electric heating equipment not having a metal covering.

#### D. Impedance Heating

**427-25. Personnel Protection.** All accessible external surfaces of the pipeline and/or vessel being heated shall be physically guarded, isolated, or thermally insulated (with weatherproof jacket for outside installations) to protect against contact by personnel in the area.

**427-26. Voltage Limitations.** The pipeline or vessel being heated shall not operate at a voltage greater than 30 volts ac.

*Exception: The voltage shall be permitted to be greater than 30 volts but not more than 80 volts if a ground-fault circuit-interrupter for personnel protection is provided.*

**427-27. Isolation Transformer.** A dual-winding transformer with a grounded shield between the primary and secondary windings shall be used to isolate the distribution system from the heating system.

**427-28. Induced Currents.** All current-carrying components shall be installed in accordance with Section 300-20.

**427-29. Grounding.** The pipeline and/or vessel being heated which is operating at a voltage greater than 30 but not more than 80 shall be grounded at designated points.

**427-30. Secondary Conductor Sizing.** The ampacity of the conductors connected to the secondary of the transformer shall be rated at least 100 percent of the total load of the heater.

#### E. Induction Heating

**427-35. Scope.** This part covers the installation of line frequency induction heating equipment and accessories for pipelines and vessels.

(FPN): See Article 665 for other applications.

**427-36. Personnel Protection.** Induction coils that operate or may operate at a voltage greater than 30 volts ac shall be enclosed in a nonmetallic or split metallic enclosure, isolated or made inaccessible by location to protect personnel in the area.

**427-37. Induced Current.** Induction coils shall be prevented from inducing circulating currents in surrounding metallic equipment, supports, or structures by shielding, isolation, or insulation of the current paths. Stray current paths shall be bonded to prevent arcing.

## F. Skin Effect Heating

**427-45. Conductor Ampacity.** The ampacity of the electrically insulated conductor inside the ferromagnetic envelope shall be permitted to exceed the values given in Article 310 provided it is identified as suitable for this use.

**427-46. Pull Boxes.** Pull boxes for pulling the electrically insulated conductor in the ferromagnetic envelope shall be permitted to be buried under the thermal insulation providing their locations are indicated by permanent markings on the insulation jacket surface and on drawings. For outdoor installations, pull boxes are to be of watertight construction.

**427-47. Single Conductor in Enclosure.** The provisions of Section 300-20 shall not apply to the installation of a single conductor in a ferromagnetic envelope (metal enclosure).

**427-48. Grounding.** The ferromagnetic envelope shall be grounded at both ends and, in addition, it shall be permitted to be grounded at intermediate points as required by its design. The ferromagnetic envelope shall be bonded at all joints to assure electrical continuity.

The provisions of Section 250-26 shall not apply to the installation of skin effect heating systems.

(FPN): See Section 250-26(d).

## G. Control and Protection

### 427-55. Disconnecting Means.

(a) **Switch or Circuit Breaker.** Means shall be provided to disconnect all fixed electric pipeline or vessel heating equipment from all ungrounded conductors. The branch-circuit switch or circuit breaker, where readily accessible to the user of the equipment, shall be permitted to serve as the disconnecting means. Switches used as disconnecting means shall be of the indicating type, and shall be provided with a positive lockout in the "off" position.

(b) **Cord- and Plug-Connected Equipment.** The factory-installed attachment plug of cord- and plug-connected equipment rated 20 amperes or less and 150 volts or less to ground shall be permitted to be the disconnecting means.

### 427-56. Controls.

(a) **Temperature Control with "Off" Position.** Temperature controlled switching devices which indicate an "off" position and which interrupt line current shall open all ungrounded conductors when the control device is in this "off" position. These devices shall not be permitted to serve as the disconnecting means unless provided with a positive lockout in the "off" position.

(b) **Temperature Control Without "Off" Position.** Temperature controlled switching devices which do not have an "off" position shall not be required to open all ungrounded conductors and shall not be permitted to serve as the disconnecting means.

(c) **Remote Temperature Controller.** Remote controlled temperature actuated devices shall not be required to meet the requirements of Section

427-56(a) and (b). These devices shall not be permitted to serve as the disconnecting means.

**(d) Combined Switching Devices.** Switching devices consisting of combined temperature actuated devices and manually controlled switches which serve both as the controllers and the disconnecting means shall comply with all the following conditions:

- (1) Open all ungrounded conductors when manually placed in the "off" position; and
- (2) Be so designed that the circuit cannot be energized automatically if the device has been manually placed in the "off" position; and
- (3) Be provided with a positive lockout in the "off" position.

**427-57. Overcurrent Protection.** Heating equipment shall be considered as protected against overcurrent where supplied by a branch circuit as specified in Section 427-4.

## ARTICLE 430 — MOTORS, MOTOR CIRCUITS, AND CONTROLLERS

### A. General

**430-1. Motor Feeder and Branch Circuits.** The following general requirements cover provisions for motors, motor circuits, and controllers that do not properly fall into the other parts of this article.

(FPN): See Article 440 for air-conditioning and refrigerating equipment.

(FPN): Diagram 430-1 is for information only.

**430-2. Adjustable Speed Drive Systems.** The incoming branch circuit or feeder to power conversion equipment included as a part of an adjustable speed drive system shall be based on the rated input to the power conversion equipment. If the power conversion equipment provides overload protection for the motor, additional overload protection is not required.

The disconnecting means shall be permitted to be in the incoming line to the conversion equipment and shall have a rating not less than 115 percent of the rated input current of the conversion unit.

**430-3. Part-Winding Motors.** A part-winding-start induction or synchronous motor is one arranged for starting by first energizing part of its primary (armature) winding and, subsequently, energizing the remainder of this winding in one or more steps. The purpose is to reduce the initial values of the starting current drawn or the starting torque developed by the motor. A standard part-winding-start induction motor is arranged so that one-half of its primary winding can be energized initially and, subsequently, the remaining half can be energized, both halves then carrying equal current. A hermetic refrigerant compressor motor shall not be considered a standard part-winding-start induction motor.

Where separate overload devices are used with a standard part-winding-start induction motor, each half of the motor winding shall be individually protected in accordance with Sections 430-32 and 430-37 with a trip current one-half that specified.

- Part A. General, Sections 430-1 through 430-18.  
 Part B. Motor Circuit Conductors, Sections 430-21 through 430-29.  
 Part C. Motor and Branch-Circuit Overload Protection, Sections 430-31 through 430-44.  
 Part D. Motor Branch-Circuit Short-Circuit and Ground-Fault Protection, Sections 430-51 through 430-58.  
 Part E. Motor Feeder Short-Circuit and Ground-Fault Protection, Sections 430-61 through 430-63.  
 Part F. Motor Control Circuits, Sections 430-71 through 430-74.  
 Part G. Motor Controllers, Sections 430-81 through 430-91.  
 Part H. Disconnecting Means, Sections 430-101 through 430-113.  
 Part J: Over 600 Volts, Nominal, Sections 430-121 through 430-127.  
 Part K. Protection of Live Parts — All Voltages, Sections 430-131 through 430-133.  
 Part L. Grounding All Voltages, Sections 430-141 through 430-145.  
 Part M. Tables, Tables 430-147 through 430-152.

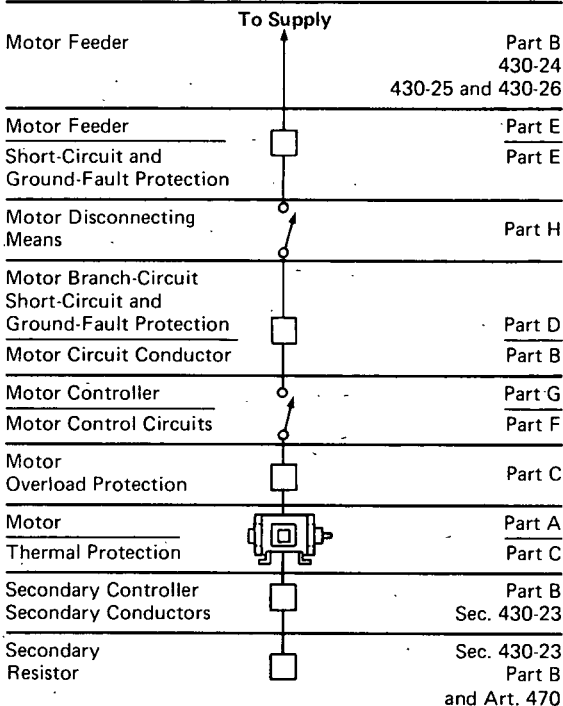

(FPN): Diagram 430-1.

Each motor-winding connection shall have branch-circuit short-circuit and ground-fault protection rated at not more than one-half that specified by Section 430-52.

*Exception: A single device having this half rating shall be permitted for both windings if it will allow the motor to start. Where a time-delay (dual-element) fuse is used as a single device for both windings, it shall be permitted to have a rating not exceeding 150 percent of motor full-load current.*

**430-5. Other Articles.** Motors and controllers shall also comply with the applicable provisions of the following:

Air-Conditioning and Refrigerating Equipment .....	Article 440
Capacitors .....	Section 460-9
Cranes and Hoists .....	Article 610
Electrically Driven or Controlled Irrigation Machines .....	Article 675
Elevators, Dumbwaiters, Escalators, and Moving Walks .....	Article 620
Garages, Aircraft Hangars, Gasoline Dispensing and Service Stations, Bulk Storage Plants, Spray Application, Dipping and Coating Processes, and Inhalation Anesthetizing Locations .....	Articles 511, 513, 514, 515, 516, and 517-G
Hazardous (Classified) Locations .....	Articles 500 thru 503
Industrial Machinery .....	Article 670
Motion-Picture Projectors .....	Sections 540-11, 540-20
Motion-Picture and Television Studios .....	Article 530
Organs .....	Section 650-3
Resistors and Reactors .....	Article 470
Theaters .....	Section 520-48

**430-6. Ampacity and Motor Rating Determination.** Conductors supplying equipment covered by this article shall be selected from Tables 310-16 through 310-31. The required ampacity and motor ratings shall be determined as specified in (a), (b) and (c) below.

**(a) General Motor Applications.** Other than as specified for torque motors in (b) below, where the current rating of a motor is used to determine the ampacity of conductors or ampere ratings of switches, branch-circuit short-circuit and ground-fault protection, etc., the values given in Tables 430-147, 430-148, 430-149, and 430-150, including notes, shall be used instead of the actual current rating marked on the motor nameplate. Separate motor overload protection shall be based on the motor nameplate current rating. Where a motor is marked in amperes, but not horsepower, the horsepower rating shall be assumed to be that corresponding to the value given in Tables 430-147, 430-148, 430-149, and 430-150, interpolated if necessary.

*Exception No. 1: Multispeed motors shall be in accordance with Sections 430-22(a) and 430-52.*

*Exception No. 2: For equipment employing a shaded-pole or permanent-split-capacitor-type fan or blower motor that is marked with the motor type, the full-load current for such motor marked on the nameplate of the equipment in which the fan or blower motor is employed shall be used instead of the horsepower rating to determine the ampacity or rating of the disconnecting means, the branch-circuit conductors, the controller, the branch-circuit short-circuit and ground-fault protection, and the separate*

*overload protection. This marking on the equipment nameplate shall not be less than the current marked on the fan or blower motor nameplate.*

**(b) Torque Motors.** For torque motors the rated current shall be locked-rotor current, and this nameplate current shall be used to determine the ampacity of the branch-circuit conductors covered in Sections 430-22 and 430-24 and the ampere rating of the motor overload protection:

(FPN): For motor controllers and disconnecting means, see Section 430-83, Exception No. 3 and Section 430-110.

**(c) AC Adjustable Voltage Motors.** For motors used in alternating-current, adjustable voltage, variable torque drive systems, the ampacity of conductors, or ampere ratings of switches, branch-circuit short-circuit and ground-fault protection, etc., shall be based on the maximum operating current marked on the motor and/or control nameplate. If the maximum operating current does not appear on the nameplate, the ampacity determination shall be based on 150 percent of the values given in Tables 430-149 and 430-150.

#### **430-7. Marking on Motors and Multimotor Equipment.**

**(a) Usual Motor Applications.** A motor shall be marked with the following information:

- (1) Maker's name.
- (2) Rated volts and full-load amperes. For a multispeed motor full-load amperes for each speed, except shaded-pole and permanent-split capacitor motors where amperes are required only for maximum speed.
- (3) Rated frequency and number of phases, if an alternating-current motor.
- (4) Rated full-load speed.
- (5) Rated temperature rise or the insulation system class and rated ambient temperature.
- (6) Time rating. The time rating shall be 5, 15, 30, or 60 minutes, or continuous.
- (7) Rated horsepower if  $\frac{1}{8}$  horsepower or more. For a multispeed motor  $\frac{1}{8}$  horsepower or more, rated horsepower for each speed, except shaded-pole and permanent-split capacitor motors  $\frac{1}{8}$  horsepower or more where rated horsepower is required only for maximum speed. Motors of arc welders are not required to be marked with the horsepower rating.
- (8) Code letter if an alternating-current motor rated  $\frac{1}{2}$  horsepower or more. On polyphase wound-rotor motors the code letter shall be omitted.  
(FPN): See (b) below.
- (9) Secondary volts and full-load amperes if a wound-rotor induction motor.
- (10) Field current and voltage for direct-current excited synchronous motors.
- (11) Winding: straight shunt, stabilized shunt, compound, or series, if a direct-current motor. Fractional horsepower dc motors 7 inches (178 mm) or less in diameter shall not be required to be marked.
- (12) A motor provided with a thermal protector complying with Section 430-32(a) (2) or (c) (2) shall be marked "Thermally Protected." Thermally protected motors rated 100 watts or less and complying with Section 430-32 (c) (2) shall be permitted to use the abbreviated marking, "T.P."



(13) A motor complying with Section 430-32(c) (4) shall be marked "Impedance Protected." Impedance protected motors rated 100 watts or less and complying with Section 430-32(c) (4) shall be permitted to use the abbreviated marking "Z.P."

(b) **Locked-Rotor Indicating Code Letters.** Code letters marked on motor nameplates to show motor input with locked rotor shall be in accordance with Table 430-7(b).

The code letter indicating motor input with locked rotor shall be in an individual block on the nameplate, properly designated. This code letter shall be used for determining branch-circuit short-circuit and ground-fault protection by reference to Table 430-152, as provided in Section 430-52.

(1) Multispeed motors shall be marked with the code letter designating the locked-rotor kVA per horsepower for the highest speed at which the motor can be started.

*Exception: Constant-horsepower multispeed motors shall be marked with the code letter giving the highest locked-rotor kVA per horsepower.*

(2) Single-speed motors starting on Y connection and running on delta connections shall be marked with a code letter corresponding to the locked-rotor kVA per horsepower for the Y connection.

(3) Dual-voltage motors that have a different locked-rotor kVA per horsepower on the two voltages shall be marked with the code letter for the voltage giving the highest locked-rotor kVA per horsepower.

(4) Motors with 60- and 50-hertz ratings shall be marked with a code letter designating the locked-rotor kVA per horsepower on 60 hertz.

(5) Part-winding-start motors shall be marked with a code letter designating the locked-rotor kVA per horsepower that is based upon the locked-rotor current for the full winding of the motor.

**Table 430-7(b). Locked-Rotor Indicating Code Letters**

Code Letter	Kilovolt-Amperes per Horsepower with Locked Rotor
A	0 — 3.14
B	3.15 — 3.54
C	3.55 — 3.99
D	4.0 — 4.49
E	4.5 — 4.99
F	5.0 — 5.59
G	5.6 — 6.29
H	6.3 — 7.09
J	7.1 — 7.99
K	8.0 — 8.99
L	9.0 — 9.99
M	10.0 — 11.19
N	11.2 — 12.49
P	12.5 — 13.99
R	14.0 — 15.99
S	16.0 — 17.99
T	18.0 — 19.99
U	20.0 — 22.39
V	22.4 — and up

(c) **Torque Motors.** Torque motors are rated for operation at standstill and shall be marked in accordance with (a) above.

*Exception: Locked-rotor torque shall replace horsepower.*

(d) **Multimotor and Combination-Load Equipment.** Multimotor and combination-load equipment shall be provided with a visible nameplate marked with the maker's name, the rating in volts, frequency, number of phases, minimum supply circuit conductor ampacity, and the maximum ampere rating of the circuit short-circuit and ground-fault protective device. The conductor ampacity shall be computed in accordance with Section 430-25 and counting all of the motors and other loads that will be operated at the same time. The short-circuit and ground-fault protective device rating shall not exceed the value computed in accordance with Section 430-53. Multimotor equipment for use on two or more circuits shall be marked with the above information for each circuit.

Where the equipment is not factory-wired and the individual nameplates of motors and other loads are visible after assembly of the equipment, the individual nameplates shall be permitted to serve as the required marking.

**430-8. Marking on Controllers.** A controller shall be marked with the maker's name or identification, the voltage, the current or horsepower rating, and such other necessary data to properly indicate the motors for which it is suitable. A controller that includes motor overload protection suitable for group motor application shall be marked with the motor overload protection and the maximum branch-circuit short-circuit and ground-fault protection for such applications.

Combination controllers employing adjustable instantaneous trip circuit breakers shall be clearly marked to indicate the ampere settings of the adjustable trip element.

Where a controller is built in as an integral part of a motor or of a motor-generator set, individual marking of the controller shall not be required if the necessary data are on the nameplate. For controllers that are an integral part of equipment approved as a unit, the above marking shall be permitted on the equipment nameplate.

#### **430-9. Terminals.**

(a) **Markings.** Terminals of motors and controllers shall be suitably marked or colored where necessary to indicate the proper connections.

(b) **Conductors.** Motor controllers and terminals of control circuit devices shall be connected with copper conductors unless identified for use with a different conductor.

(c) **Torque Requirements.** Control circuit devices with screw-type pressure terminals used with No. 14 AWG or smaller copper conductors shall be torqued to a minimum of 7 pound-inches (0.79 N-m) unless identified for a different torque value.

#### **430-10. Wiring Space in Enclosures.**

(a) **General.** Enclosures for motor controllers and disconnecting means shall not be used as junction boxes, auxiliary gutters, or raceways for conductors feeding through or tapping off to the other apparatus unless designs are employed which provide adequate space for this purpose.

(FPN): See Section 373-8 for switch and overcurrent-device enclosures.

(b) **Wire Bending Space in Enclosures.** Minimum wire bending space within the enclosures for motor controllers shall be in accordance with Table 430-10(b) when measured in a straight line from the end of the lug or wire connector (in the direction the wire leaves the terminal) to the wall or barrier. Where alternate wire termination means is substituted for that supplied by the manufacturer of the controller, it shall be of a type identified by the manufacturer for use with the controller and shall not reduce the minimum wire bending space.

Where the enclosure is a motor control center, the minimum wire bending space shall be in accordance with requirements of Article 373.

**Table 430-10(b). Minimum Wire Bending Space at the Terminals of Enclosed Motor Controllers (in Inches)**

AWG or Circular-Mil Size of Wire	*Wires per Terminal	
	1	2
14-10	Not specified	—
8-6	1½	—
4-3	2	—
2	2½	—
1	3	—
1/0	5	5
2/0	6	6
3/0-4/0	7	7
250	8	8
300	10	10
350-500	12	12
600-700	14	16
750-900	18	19

\* Where provision for 3 or more wires per terminal exists the minimum wire bending space shall be in accordance with the requirements of Article 373.

**430-11. Protection Against Liquids.** Suitable guards or enclosures shall be provided to protect exposed current-carrying parts of motors and the insulation of motor leads where installed directly under equipment, or in other locations where dripping or spraying oil, water, or other injurious liquid may occur, unless the motor is designed for the existing conditions.

#### **430-12. Motor Terminal Housings.**

(a) **Material.** Where motors are provided with terminal housings, the housings shall be of metal and of substantial construction.

*Exception: In other than hazardous (classified) locations, substantial, nonmetallic, nonburning housings shall be permitted provided an internal grounding means between the motor frame and the equipment grounding connection is incorporated within the housing.*

(b) **Dimensions and Space — Wire-to-Wire Connections.** When these terminal housings enclose wire-to-wire connections, they shall have minimum dimensions and usable volumes in accordance with Table 430-12(b).

**Table 430-12(b). Terminal Housings — Wire-to-Wire Connections — Motors 11 Inches in Diameter or Less**

HP	Cover Opening, Minimum Dimension, Inches	Usable Volume, Minimum, Cubic Inches
1 and smaller*	1 $\frac{3}{8}$	7 $\frac{1}{2}$
1 $\frac{1}{2}$ , 2 and 3†	1 $\frac{3}{4}$	12
5 and 7 $\frac{1}{2}$	2	16
10 and 15	2 $\frac{1}{2}$	26

For SI units: one inch = 25.4 millimeters.

\* For motors rated 1 horsepower and smaller and with the terminal housing partially or wholly integral with the frame or end shield, the volume of the terminal housing shall be not less than 0.8 cubic inch per wire-to-wire connection. The minimum cover opening dimension is not specified.

† For motors rated 1 $\frac{1}{2}$ , 2 and 3 horsepower and with the terminal housing partially or wholly integral with the frame or end shield, the volume of the terminal housing shall not be less than 1.0 cubic inch per wire-to-wire connection. The minimum cover opening dimension is not specified.

### Motors Over 11 Inches in Diameter

#### Alternating-Current Motors

Max. Full-load Current for Three- phase Motors with Max. of Twelve Leads Amperes	Terminal Box Minimum Dimension Inches	Usable Volume Minimum Cubic Inches	Typical Maximum Horsepower Three Phase	
			230 Volt	460 Volt
45	2.5	26	15	30
70	3.3	55	25	50
110	4.0	100	40	75
160	5.0	180	60	125
250	6.0	330	100	200
400	7.0	600	150	300
600	8.0	1100	250	500

For SI units: one inch = 25.4 millimeters.

#### Direct-Current Motors

Maximum Full-Load Current for Motors with Maximum of Six Leads Amperes	Terminal Box Minimum Dimensions Inches	Usable Volume, Minimum, Cubic Inches
68	2.5	26
105	3.3	55
165	4.0	100
240	5.0	180
375	6.0	330
600	7.0	600
900	8.0	1100

For SI units: one inch = 25.4 millimeters.

Auxiliary leads for such items as brakes, thermostats, space heater, exciting fields, etc., may be neglected if their current-carrying area does not exceed 25 percent of the current-carrying area of the machine power leads.

(c) **Dimensions and Space — Fixed Terminal Connections.** Where these terminal housings enclose rigidly mounted motor terminals, the terminal housing shall be of sufficient size to provide minimum terminal spacings and usable volumes in accordance with Tables 430-12(c)(1) and (c)(2).

**Table 430-12(c) (1). Terminal Spacings — Fixed Terminals**

Nominal Volts	Minimum Spacing, Inches	
	Between Line Terminals	Between Line Terminals and Other Uninsulated Metal Parts
240 or less	¼	¼
Over 250 through 600	⅜	⅜

For SI units: one inch = 25.4 millimeters.

**Table 430-12(c) (2). Usable Volumes — Fixed Terminals**

Power-Supply Conductor Size, AWG	Minimum Usable Volume per Power-Supply Conductor, Cubic Inches
14	1.0
12 and 10	1¼
8 and 6	2¼

For SI units: one inch = 25.4 millimeters.

(d) **Large Wire or Factory Connections.** For motors with larger ratings, greater number of leads, or larger wire sizes, or where motors are installed as a part of factory-wired equipment, without additional connection being required at the motor terminal housing during equipment installation, the terminal housing shall be of ample size to make connections, but the foregoing provisions for the volumes of terminal housings shall not be considered applicable.

(e) **Equipment Grounding Connections.** A means for attachment of an equipment grounding conductor termination in accordance with Section 250-113 shall be provided at motor terminal housings for wire-to-wire connections or fixed terminal connections. The means for such connections shall be permitted to be located either inside or outside the motor terminal housing.

*Exception: Where a motor is installed as a part of factory-wired equipment, which is required to be grounded and without additional connection being required at the motor terminal housing during equipment installation, a separate means for motor grounding at the motor terminal housing shall not be required.*

**430-13. Bushing.** Where wires pass through an opening in an enclosure, conduit box, or barrier, a bushing shall be used to protect the conductors from the edges of openings having sharp edges. The bushing shall have

smooth well-rounded surfaces where it may be in contact with the conductors. If used where oils, greases, or other contaminants may be present, the bushing shall be made of material not deleteriously affected.

(FPN): For conductors exposed to deteriorating agents; see Section 310-9.

#### **430-14. Location of Motors.**

(a) **Ventilation and Maintenance.** Motors shall be located so that adequate ventilation is provided and so that maintenance, such as lubrication of bearings and replacing of brushes, can be readily accomplished.

(b) **Open Motors.** Open motors having commutators or collector rings shall be located or protected so that sparks cannot reach adjacent combustible material, but this shall not prohibit the installation of these motors on wooden floors or supports.

**430-16. Exposure to Dust Accumulations.** In locations where dust or flying material will collect on or in motors in such quantities as to seriously interfere with the ventilation or cooling of motors and thereby cause dangerous temperatures, suitable types of enclosed motors that will not overheat under the prevailing conditions shall be used.

(FPN): Especially severe conditions may require the use of enclosed pipe-ventilated motors, or enclosure in separate dusttight rooms, properly ventilated from a source of clean air.

**430-17. Highest Rated (Largest) Motor.** In determining compliance with Sections 430-24, 430-53(b), and 430-53(c), the highest rated (largest) motor shall be considered to be that motor having the highest rated full-load current. The full-load current used to determine the highest rated motor shall be the equivalent value corresponding to the motor horsepower rating selected from Tables 430-147, 430-148, 430-149, and 430-150.

**430-18. Nominal Voltage of Rectifier Systems.** The nominal value of the ac voltage being rectified shall be used to determine the voltage of a rectifier derived system.

*Exception: The nominal dc voltage of the rectifier shall be used if it exceeds the peak value of the ac voltage being rectified.*

### **B. Motor Circuit Conductors**

**430-21. General.** Part B specifies sizes of conductors capable of carrying the motor current without overheating under the conditions specified:

*Exception: The provisions of Section 430-124 shall apply over 600 volts, nominal.*

The provisions of Articles 250, 300, and 310 shall not apply to conductors that form an integral part of approved equipment, or to integral conductors of motors, motor controllers, and the like.

(FPN): See Sections 300-1(b) and 310-1.

(FPN): See Section 430-9(b) for equipment device terminal requirements.

#### **430-22. Single Motor.**

(a) **General.** Branch-circuit conductors supplying a single motor shall have an ampacity not less than 125 percent of the motor full-load current rating.

In case of a multispeed motor, the selection of branch-circuit conductors on the line side of the controller shall be based on the highest of the full-load current ratings shown on the motor nameplate; selection of branch-circuit conductors between the controller and the motor, which are energized for that particular speed, shall be based on the current rating for that speed.

(FPN): See Example No. 8, Chapter 9 and Diagram 430-1.

*Exception No. 1: Conductors for a motor used for short-time, intermittent, periodic, or varying duty shall have an ampacity not less than the percentage of the motor nameplate current rating shown in Table 430-22(a) Exception unless the authority having jurisdiction grants special permission for conductors of smaller size.*

*Exception No. 2: For direct-current motors operating from a rectified single-phase power supply, the conductors between the controller and the motor shall have an ampacity of not less than the following percent of the motor full-load current rating:*

a. Where a rectifier bridge of the single-phase half-wave type is used, 190 percent.

b. Where a rectifier bridge of the single-phase full-wave type is used, 150 percent.

**Table 430-22(a) Exception. Duty-Cycle Service**

Classification of Service	Percentages of Nameplate Current Rating			
	5-Minute Rated Motor	15-Minute Rated Motor	30 & 60 Minute Rated Motor	Continuous Rated Motor
Short-Time Duty Operating valves, raising or lowering rolls, etc. ....	110	120	150	...
Intermittent Duty Freight and passenger elevators, tool heads, pumps, drawbridges, turntables, etc. For arc welders, see Section 630-21 .....	85	85	90	140
Periodic Duty Rolls, ore- and coal-handling machines, etc. ....	85	90	95	140
Varying Duty .....	110	120	150	200

Any motor application shall be considered as continuous duty unless the nature of the apparatus it drives is such that the motor will not operate continuously with load under any condition of use.

**(b) Separate Terminal Enclosure.** The conductors between a stationary motor rated 1 horsepower or less and the separate terminal enclosure permitted in Section 430-145(b) shall be permitted to be smaller than No. 14 but not smaller than No. 18, provided they have an ampacity as specified in (a) above.

**430-23. Wound-Rotor Secondary.**

(a) **Continuous Duty.** For continuous duty, the conductors connecting the secondary of a wound-rotor alternating-current motor to its controller shall have an ampacity not less than 125 percent of the full-load secondary current of the motor.

(b) **Other than Continuous Duty.** For other than continuous duty, these conductors shall have an ampacity, in percent of full-load secondary current, not less than that specified in Table 430-22(a) Exception.

(c) **Resistor Separate from Controller.** Where the secondary resistor is separate from the controller, the ampacity of the conductors between controller and resistor shall not be less than that given in Table 430-23(c).

**Table 430-23(c). Secondary Conductor**

Resistor Duty Classification	Ampacity of Conductor in Percent of Full-Load Secondary Current
Light starting duty .....	35
Heavy starting duty .....	45
Extra-heavy starting duty .....	55
Light intermittent duty .....	65
Medium intermittent duty .....	75
Heavy intermittent duty .....	85
Continuous duty .....	110

**430-24. Conductors Supplying Several Motors.** Conductors supplying two or more motors shall have an ampacity equal to the sum of the full-load current rating of all the motors plus 25 percent of the highest rated motor in the group.

Where one or more motors of the group are used on short-time, intermittent, periodic, or varying duty, the ampacity of the conductors shall be computed as follows:

(1) Determine the needed ampere rating for each motor used for other than continuous duty from Table 430-22(a) Exception.

(2) Determine the needed ampere rating for each continuous-duty motor based on 100 percent motor full-load current rating.

(3) Multiply the largest single motor ampere rating determined from (1) or (2) above by 1.25. Add all other motor ampere ratings from (1) and (2) above and select the conductor ampacity for this total ampere rating.

*Exception: Where the circuitry is so interlocked as to prevent the starting and running of a second motor or group of motors, the conductor size shall be determined from the larger motor or group of motors that is to be operated at a given time.*

(FPN): See Example No. 8, Chapter 9.

**430-25. Conductors Supplying Motors and Other Loads.**

(a) **Combination Load.** Conductors supplying a motor load and in addition a lighting or appliance load shall have an ampacity sufficient for the lighting or appliance load computed in accordance with Article 220 and other



applicable sections plus the motor load determined in accordance with Section 430-24 or, for a single motor, in accordance with Section 430-22.

*Exception: The ampacity of conductors supplying motor-operated fixed electric space heating equipment shall conform with Section 424-3(b).*

**(b) Multimotor and Combination-Load Equipment.** The ampacity of the conductors supplying multimotor and combination-load equipment shall not be less than the minimum circuit ampacity marked on the equipment in accordance with Section 430-7(d).

**430-26. Feeder Demand Factor.** Where reduced heating of the conductors results from motors operating on duty-cycle, intermittently, or from all motors not operating at one time, the authority having jurisdiction may grant permission for feeder conductors to have an ampacity less than specified in Sections 430-24 and 430-25, provided the conductors have sufficient ampacity for the maximum load determined in accordance with the sizes and number of motors supplied and the character of their loads and duties.

**430-27. Capacitors with Motors:** Where capacitors are installed in motor circuits, conductors shall comply with Sections 460-8 and 460-9.

**430-28. Feeder Taps.** Feeder tap conductors shall have an ampacity not less than that required by Part B, shall terminate in a branch-circuit protective device and, in addition, shall meet one of the following requirements: (1) be enclosed by either an enclosed controller or by a raceway and be not more than 10 feet (3.05 m) in length; or (2) have an ampacity of at least one-third that of the feeder conductors, be protected from physical damage and be not more than 25 feet (7.62 m) in length; or (3) have the same ampacity as the feeder conductors.

*Exception: Feeder Taps Over 25 Feet (7.62 m) Long. In high-bay manufacturing buildings (over 35 feet (10.67 m) high at walls) conductors tapped to a feeder shall be permitted to be not over 25 feet (7.62 m) long horizontally and not over 100 feet (30.5) total length where all of the following conditions are met:*

*a. The ampacity of the tap conductors is not less than one-third that of the feeder conductors.*

*b. The tap conductors terminate with a single circuit breaker or a single set of fuses conforming with (1) Part D if the tap is a branch circuit or (2) Part E if the tap is a feeder.*

*c. The tap conductors are suitably protected from physical damage and are installed in raceways.*

*d. The tap conductors are continuous from end-to-end and contain no splices.*

*e. The tap conductors shall be No. 6 AWG copper or No. 4 AWG aluminum or larger.*

*f. The tap conductors shall not penetrate walls, floors, or ceilings.*

**430-29. Constant Voltage DC Motors — Power Resistors.** Conductors connecting the motor-controller to separately mounted power accelerating and dynamic braking resistors in the armature circuit shall have an ampacity not less than the value calculated from Table 430-29 using motor full-load current. If an armature shunt resistor is used, the power accelerating resistor

conductor ampacity shall be calculated using the total of motor full-load current and armature shunt resistor current.

Armature shunt resistor conductors shall have an ampacity of not less than that calculated from Table 430-29 using rated shunt resistor current as full-load current.

**Table 430-29. Conductor Rating Factors for Power Resistors**

Time in Seconds		Ampacity of Conductor in Percent of Full-Load Current
On	Off	
5	75	35
10	70	45
15	75	55
15	45	65
15	30	75
15	15	85
Continuous Duty		110

### C. Motor and Branch-Circuit Overload Protection

**430-31. General.** Part C specifies overload devices intended to protect motors, motor-control apparatus, and motor branch-circuit conductors against excessive heating due to motor overloads and failure to start.

Overload in electrical apparatus is an operating overcurrent which, when it persists for a sufficient length of time, would cause damage or dangerous overheating of the apparatus. It does not include short circuits or ground faults.

These provisions shall not be interpreted as requiring overload protection where it might introduce additional or increased hazards, as in the case of fire pumps.

(FPN): See Installation of Centrifugal Fire Pumps, NFPA 20-1983 (ANSI).

The provisions of Part C shall not apply to motor circuits rated over 600 volts, nominal. See Part J.

(FPN): See Example No. 8, Chapter 9.

### 430-32. Continuous-Duty Motors.

(a) **More than 1 Horsepower.** Each continuous-duty motor rated more than 1 horsepower shall be protected against overload by one of the following means:

(1) A separate overload device that is responsive to motor current. This device shall be selected to trip or rated at no more than the following percent of the motor nameplate full-load current rating.

Motors with a marked service factor not less than 1.15 .....	125%
Motors with a marked temperature rise not over 40°C .....	125%
All other motors .....	115%

Modification of this value shall be permitted as provided in Section 430-34.

For a multispeed motor, each winding connection shall be considered separately.

Where a separate motor overload device is so connected that it does not carry the total current designated on the motor nameplate, such as for wye-delta starting, the proper percentage of nameplate current applying to the selection or setting of the overload device shall be clearly designated on the equipment, or the manufacturer's selection table shall take this into account.

(2) A thermal protector integral with the motor, approved for use with the motor it protects on the basis that it will prevent dangerous overheating of the motor due to overload and failure to start. The ultimate trip current of a thermally protected motor shall not exceed the following percentage of motor full-load current given in Tables 430-148, 430-149, and 430-150.

Motor full-load current not exceeding 9 amperes .....	170%
Motor full-load current 9.1 to and including 20 amperes .....	156%
Motor full-load current greater than 20 amperes .....	140%

If the motor current-interrupting device is separate from the motor and its control circuit is operated by a protective device integral with the motor, it shall be so arranged that the opening of the control circuit will result in interruption of current to the motor.

(3) A protective device integral with a motor that will protect the motor against damage due to failure to start shall be permitted if the motor is part of an approved assembly that does not normally subject the motor to overloads.

(4) For motors larger than 1500 horsepower, a protective device having embedded temperature detectors that cause current to the motor to be interrupted when the motor attains a temperature rise greater than marked on the nameplate in an ambient of 40°C.

**(b) One Horsepower or Less, Nonautomatically Started.**

(1) Each continuous-duty motor rated at 1 horsepower or less that is not permanently installed, is nonautomatically started, and is within sight from the controller location shall be permitted to be protected against overload by the branch-circuit short-circuit and ground-fault protective device. This branch-circuit protective device shall not be larger than that specified in Part D of Article 430.

*Exception: Any such motor shall be permitted on a nominal 120-volt branch circuit protected at not over 20 amperes.*

(2) Any such motor that is not in sight from the controller location shall be protected as specified in Section 430-32(c). Any motor rated at 1 horsepower or less that is permanently installed shall be protected in accordance with Section 430-32(c).

**(c) One Horsepower or Less, Automatically Started.** Any motor of 1 horsepower or less that is started automatically shall be protected against overload by one of the following means:

(1) A separate overload device that is responsive to motor current. This device shall be selected to trip or rated at no more than the following percentage of the motor nameplate full-load current rating.

Motors with a marked service factor not less than 1.15 .....	125%
Motors with a marked temperature rise not over 40°C .....	125%
All other motors .....	115%

For a multispeed motor, each winding connection shall be considered separately. Modification of this value shall be permitted as provided in Section 430-34.

(2) A thermal protector integral with the motor, approved for use with the motor which it protects on the basis that it will prevent dangerous overheating of the motor due to overload and failure to start. Where the motor current interrupting device is separate from the motor and its control circuit is operated by a protective device integral with the motor, it shall be so arranged that the opening of the control circuit will result in interruption of current to the motor.

(3) A protective device integral with a motor that will protect the motor against damage due to failure to start shall be permitted (1) if the motor is part of an approved assembly that does not subject the motor to overloads, or (2) if the assembly is also equipped with other safety controls (such as the safety combustion controls on a domestic oil burner) that protect the motor against damage due to failure to start. Where the assembly has safety controls that protect the motor, it shall be so indicated on the nameplate of the assembly where it will be visible after installation.

(4) In case the impedance of the motor windings is sufficient to prevent overheating due to failure to start, the motor shall be permitted to be protected as specified in Section 430-32(b)(1) for manually started motors if the motor is part of an approved assembly in which the motor will limit itself so that it will not be dangerously overheated.

(FPN): Many alternating-current motors of less than  $\frac{1}{20}$  horsepower, such as clock motors, series motors, etc., and also some larger motors such as torque motors, come within this classification. It does not include split-phase motors having automatic switches that disconnect the starting windings.

(d) **Wound-Rotor Secondaries.** The secondary circuits of wound-rotor alternating-current motors, including conductors, controllers, resistors, etc., shall be permitted to be protected against overload by the motor-overload device.

**430-33. Intermittent and Similar Duty.** A motor used for a condition of service that is inherently short-time, intermittent, periodic, or varying duty, as illustrated by Table 430-22(a) Exception, shall be permitted to be protected against overload by the branch-circuit short-circuit and ground-fault protective device, provided the protective device rating or setting does not exceed that specified in Table 430-152.

Any motor application shall be considered to be for continuous duty unless the nature of the apparatus it drives is such that the motor cannot operate continuously with load under any condition of use.

**430-34. Selection of Overload Relay.** Where the overload relay selected in accordance with Section 430-32(a)(1) and (c)(1) is not sufficient to start the motor or to carry the load, the next higher size overload relay shall be permitted to be used provided the trip current of the overload relay does not exceed the following percentage of motor full-load current rating.

Motors with marked service factor not less than 1.15 .....	140%
Motors with a marked temperature rise not over 40°C .....	140%
All other motors .....	130%

If not shunted during the starting period of the motor as provided in Section 430-35, the overload device shall have sufficient time delay to permit the motor to start and accelerate its load.

#### **430-35. Shunting During Starting Period.**

(a) **Nonautomatically Started.** For a nonautomatically started motor the overload protection shall be permitted to be shunted or cut out of the circuit during the starting period of the motor if the device by which the overload protection is shunted or cut out cannot be left in the starting position and if fuses or inverse time circuit breakers rated or set at not over 400 percent of the full-load current of the motor are so located in the circuit as to be operative during the starting period of the motor.

(b) **Automatically Started.** The motor overload protection shall not be shunted or cut out during the starting period if the motor is automatically started.

*Exception: The motor overload protection shall be permitted to be shunted or cut out during the starting period on an automatically started motor where:*

(1) *The motor starting period exceeds the time delay of available motor overload protective devices, and*

(2) *Listed means are provided to:*

a. *Sense motor rotation and to automatically prevent the shunting or cutout in the event that the motor fails to start, and*

b. *Limit the time of overload protection shunting or cutout to less than the locked rotor time rating of the protected motor, and*

c. *Provide for shutdown and manual restart if motor running condition is not reached.*

**430-36. Fuses — In Which Conductor.** Where fuses are used for motor overload protection, a fuse shall be inserted in each ungrounded conductor.

A fuse shall also be inserted in the grounded conductor if the supply system is 3-wire, 3-phase ac with one conductor grounded.

**430-37. Devices Other than Fuses — In Which Conductor.** Where devices other than fuses are used for motor overload protection, Table 430-37 shall govern the minimum allowable number and location of overload units such as trip coils, relays, or thermal cutouts.

**430-38. Number of Conductors Opened by Overload Device.** Motor overload devices other than fuses, thermal cutouts, or thermal protectors shall simultaneously open a sufficient number of ungrounded conductors to interrupt current flow to the motor.

**430-39. Motor Controller as Overload Protection.** A motor controller shall also be permitted to serve as an overload device if the number of overload units complies with Table 430-37 and if these units are operative in both the

**Table 430-37. Overload Units**

Kind of Motor	Supply System	Number and location of overload units, such as trip coils, relays, or thermal cutouts
1-phase ac or dc	2-wire, 1-phase ac or dc ungrounded	1 in either conductor
1-phase ac or dc	2-wire, 1-phase ac or dc, one conductor grounded	1 in ungrounded conductor
1-phase ac or dc	3-wire, 1-phase ac or dc, grounded-neutral	1 in either ungrounded conductor
2-phase ac	3-wire, 2-phase ac, ungrounded	2, one in each phase
2-phase ac	3-wire, 2-phase ac, one conductor grounded	2 in ungrounded conductors
2-phase ac	4-wire, 2-phase ac, grounded or ungrounded	2, one per phase in ungrounded conductors
2-phase ac	5-wire, 2-phase ac, grounded neutral or ungrounded	2, one per phase in any ungrounded phase wire
3-phase ac	Any 3-phase	*3, one in each phase

\* *Exception: Where protected by other approved means.*

starting and running position in the case of a direct-current motor, and in the running position in the case of an alternating-current motor.

**430-40. Thermal Cutouts and Overload Relays.** Thermal cutouts, overload relays, and other devices for motor overload protection that are not capable of opening short circuits shall be protected by fuses or circuit breakers with ratings or settings in accordance with Section 430-52 or by a motor short-circuit protector in accordance with Section 430-52.

*Exception No. 1: Where approved for group installation and marked to indicate the maximum size of fuse or inverse time circuit breaker by which they must be protected.*

*Exception No. 2: The fuse or circuit breaker ampere rating shall be permitted to be marked on the nameplate of approved equipment in which the thermal cutout or overload relay is used.*

(FPN): For instantaneous trip circuit breakers or motor short-circuit protectors, see Section 430-52.

**430-42. Motors on General-Purpose Branch Circuits.** Overload protection for motors used on general-purpose branch circuits as permitted in Article 210 shall be provided as specified in (a), (b), (c), or (d) below.

(a) **Not Over 1 Horsepower.** One or more motors without individual overload protection shall be permitted to be connected to a general-purpose branch circuit only where the installation complies with the limiting conditions specified in Section 430-32(b) and (c) and Section 430-53(a)(1) and (a)(2).

(b) **Over 1 Horsepower.** Motors of larger ratings than specified in Section 430-53(a) shall be permitted to be connected to general-purpose branch circuits only where each motor is protected by overload protection selected to protect the motor as specified in Section 430-32. Both the controller and the motor overload device shall be approved for group installation with the short-circuit and ground-fault protective device selected in accordance with Section 430-53.

(c) **Cord- and Plug-Connected.** Where a motor is connected to a branch circuit by means of an attachment plug and receptacle and individual overload protection is omitted as provided in (a) above, the rating of the attachment plug and receptacle shall not exceed 15 amperes at 125 volts or 10 amperes at 250 volts. Where individual overload protection is required as provided in (b) above for a motor or motor-operated appliance that is attached to the branch circuit through an attachment plug and receptacle, the overload device shall be an integral part of the motor or of the appliance. The rating of the attachment plug and receptacle shall determine the rating of the circuit to which the motor may be connected, as provided in Article 210.

(d) **Time Delay.** The branch-circuit short-circuit and ground-fault protective device protecting a circuit to which a motor or motor-operated appliance is connected shall have sufficient time delay to permit the motor to start and accelerate its load.

**430-43. Automatic Restarting.** A motor overload device that can restart a motor automatically after overload tripping shall not be installed unless approved for use with the motor it protects. A motor that can restart automatically after shutdown shall not be installed if its automatic restarting can result in injury to persons.

**430-44. Orderly Shutdown.** If immediate automatic shutdown of a motor by a motor overload protective device(s) would introduce additional or increased hazard(s) to a person(s) and continued motor operation is necessary for safe shutdown of equipment or process, a motor overload sensing device(s) conforming with the provisions of Part C of this article shall be permitted to be connected to a supervised alarm instead of causing immediate interruption of the motor circuit, so that corrective action or an orderly shutdown can be initiated.

#### **D. Motor Branch-Circuit Short-Circuit and Ground-Fault Protection**

**430-51. General.** Part D specifies devices intended to protect the motor branch-circuit conductors, the motor control apparatus, and the motors against overcurrent due to short circuits or grounds. They add to or amend the provisions of Article 240. The devices specified in Part D do not include the types of devices required by Sections 210-8, 230-95, and 305-6.

The provisions of Part D do not apply to motor circuits rated over 600 volts, nominal. See Part J.

(FPN): See Example No. 8, Chapter 9.

**430-52. Rating or Setting for Individual Motor Circuit.** The motor branch-circuit short-circuit and ground-fault protective device shall be capable of carrying the starting current of the motor. A protective device having a rating

or setting not exceeding the value calculated according to the values given in Table 430-152 shall be used.

*Exception No. 1: Where the values for branch-circuit short-circuit and ground-fault protective devices determined by Table 430-152 do not correspond to the standard sizes or ratings of fuses, nonadjustable circuit breakers, thermal protective devices, or possible settings of adjustable circuit breakers, any of which are adequate to carry the load, the next higher size, rating, or setting shall be permitted.*

*Exception No. 2: Where the rating specified in Table 430-152 is not sufficient for the starting current of the motor:*

*a. The rating of a nontime-delay fuse not exceeding 600 amperes shall be permitted to be increased but shall in no case exceed 400 percent of the full-load current.*

*b. The rating of a time-delay (dual element) fuse shall be permitted to be increased but shall in no case exceed 225 percent of the full-load current.*

*c. The rating of an inverse time circuit breaker shall be permitted to be increased but shall in no case exceed (1) 400 percent for full-load currents of 100 amperes or less, or (2) 300 percent for full-load currents greater than 100 amperes.*

*d. The rating of a fuse of 601-6000 ampere classification shall be permitted to be increased but shall in no case exceed 300 percent of the full-load current.*

*Exception No. 3: Torque motor branch circuits shall be protected at the motor nameplate current rating in accordance with Section 240-3, Exception No. 1.*

(FPN): See Section 240-6 for standard ratings of fuses and circuit breakers.

An instantaneous trip circuit breaker shall be used only if adjustable, and if part of a combination controller having motor overload and also short-circuit and ground-fault protection in each conductor. A motor short-circuit protector shall be permitted in lieu of devices listed in Table 430-152 if the motor short-circuit protector is part of a combination controller having both motor overload protection and short-circuit and ground-fault protection in each conductor and if it will operate at not more than 1300 percent of full-load motor current. An instantaneous trip circuit breaker or motor short-circuit protector shall be used only as part of a combination motor controller which provides coordinated motor branch-circuit overload and short-circuit and ground-fault protection.

*Exception: Where the setting specified in Table 430-152 is not sufficient for the starting current of the motor, the setting of an instantaneous trip circuit breaker shall be permitted to be increased but shall in no case exceed 1300 percent of the motor full-load current.*

For a multispeed motor, a single short-circuit and ground-fault protective device shall be permitted for two or more windings of the motor, provided the rating of the protective device does not exceed the above applicable percentage of the nameplate rating of the smallest winding protected.

Where maximum branch-circuit short-circuit and ground-fault protective device ratings are shown in the manufacturer's overload relay table for use with a motor controller or are otherwise marked on the equipment, they shall not be exceeded even if higher values are allowed as shown above.



(FPN): See Example No. 8 in Chapter 9 and Diagram 430-1.

Suitable fuses shall be permitted in lieu of devices listed in Table 430-152 for an adjustable speed drive system provided that the marking for replacement fuses is provided adjacent to the fuses.

**430-53. Several Motors or Loads on One Branch Circuit.** Two or more motors or one or more motors and other loads shall be permitted to be connected to the same branch circuit under the conditions specified in (a), (b), or (c) below.

**(a) Not Over 1 Horsepower.** Several motors each not exceeding 1 horsepower in rating shall be permitted on a nominal 120 volt branch circuit protected at not over 20 amperes or a branch circuit of 600 volts, nominal, or less, protected at not over 15 amperes, if all of the following conditions are met:

- (1) The full-load rating of each motor does not exceed 6 amperes.
- (2) The rating of the branch-circuit short-circuit and ground-fault protective device marked on any of the controllers is not exceeded.
- (3) Individual overload protection conforms to Section 430-32.

**(b) If Smallest Motor Protected.** If the branch-circuit short-circuit and ground-fault protective device is selected not to exceed that allowed by Section 430-52 for the motor of the smallest rating, two or more motors or one or more motors and other load(s), with each motor having individual overload protection, shall be permitted to be connected to a branch circuit where it can be determined that the branch-circuit short-circuit and ground-fault protective device will not open under the most severe normal conditions of service that might be encountered.

**(c) Other Group Installations.** Two or more motors of any rating or one or more motors and other load(s), with each motor having individual overload protection, shall be permitted to be connected to one branch circuit where the motor controller(s) and overload device(s) are (1) installed as a listed factory assembly and the motor branch-circuit short-circuit and ground-fault protective device is either provided as part of the assembly or is specified by a marking on the assembly, or (2) the motor branch-circuit short-circuit and ground-fault protective device, the motor controller(s) and overload device(s) are field-installed as separate assemblies listed for such use and provided with manufacturers' instructions for use with each other, and (3) all of the following conditions are complied with:

- (1) Each motor overload device is listed for group installation with a specified maximum rating of fuse and/or inverse time circuit breaker.
- (2) Each motor controller is listed for group installation with a specified maximum rating of fuse and/or circuit breaker.
- (3) Each circuit breaker is one of the inverse time type and listed for group installation.

(4) The branch circuit shall be protected by fuses or inverse time circuit breakers having a rating not exceeding that specified in Section 430-52 for the largest motor connected to the branch circuit plus an amount equal to the sum of the full-load current ratings of all other motors and the ratings of other loads connected to the circuit. Where this calculation results in a rating less than the ampacity of the supply conductors, it shall be permitted to increase

the maximum rating of the fuses or circuit breaker to a value not exceeding that permitted by Section 240-3, Exception No. 1.

(5) The branch-circuit fuses or inverse time circuit breakers are not larger than allowed by Section 430-40 for the thermal cutout or overload relay protecting the smallest motor of the group.

(FPN): See Section 110-10.

(d) **Single Motor Taps.** For group installations described above, the conductors of any tap supplying a single motor shall not be required to have an individual branch-circuit short-circuit and ground-fault protective device, provided they comply with either of the following: (1) no conductor to the motor shall have an ampacity less than that of the branch-circuit conductors, or (2) no conductor to the motor shall have an ampacity less than one-third that of the branch-circuit conductors, with a minimum in accordance with Section 430-22; the conductors to the motor overload device being not more than 25 feet (7.62 m) long and being protected from physical damage.

**430-54. Multimotor and Combination-Load Equipment.** The rating of the branch-circuit short-circuit and ground-fault protective device for multimotor and combination-load equipment shall not exceed the rating marked on the equipment in accordance with Section 430-7(d).

**430-55. Combined Overcurrent Protection.** Motor branch-circuit short-circuit and ground-fault protection and motor overload protection shall be permitted to be combined in a single protective device where the rating or setting of the device provides the overload protection specified in Section 430-32.

**430-56. Branch-Circuit Protective Devices — In Which Conductor.** Branch-circuit protective devices shall comply with the provisions of Section 240-20.

**430-57. Size of Fuseholder.** Where fuses are used for motor branch-circuit short-circuit and ground-fault protection, the fuseholders shall not be of a smaller size than required to accommodate the fuses specified by Table 430-152.

*Exception: Where fuses having time delay appropriate for the starting characteristics of the motor are used, fuseholders of smaller size than specified in Table 430-152 shall be permitted.*

**430-58. Rating of Circuit Breaker.** A circuit breaker for motor branch-circuit short-circuit and ground-fault protection shall have a current rating in accordance with Sections 430-52 and 430-110.

### **E. Motor Feeder Short-Circuit and Ground-Fault Protection**

**430-61. General.** Part E specifies protective devices intended to protect feeder conductors supplying motors against overcurrents due to short circuits or grounds.

(FPN): See Example No. 8, Chapter 9.

**430-62. Rating or Setting — Motor Load.**

(a) **Specific Load.** A feeder supplying a specific fixed motor load(s) and consisting of conductor sizes based on Section 430-24 shall be provided with

a protective device having a rating or setting not greater than the largest rating or setting of the branch-circuit short-circuit and ground-fault protective device for any motor of the group (based on Table 430-152, or Section 440-22(a) for hermetic refrigerant motor-compressors), plus the sum of the full-load currents of the other motors of the group.

Where the same rating or setting of the branch-circuit short-circuit and ground-fault protective device is used on two or more of the branch circuits of the group, one of the protective devices shall be considered the largest for the above calculations.

(FPN): See Example No. 8, Chapter 9.

**(b) Future Additions.** For large-capacity installations, where heavy-capacity feeders are installed to provide for future additions or changes, the rating or setting of the feeder protective devices shall be permitted to be based on the ampacity of the feeder conductors.

**430-63. Rating or Setting — Power and Light Loads.** Where a feeder supplies a motor load, and in addition a lighting or a lighting and appliance load, the feeder protective device shall be permitted to have a rating or setting sufficient to carry the lighting or the lighting and appliance load as determined in accordance with Articles 210 and 220, plus for a single motor, the rating permitted by Section 430-52, and for two or more motors, the rating permitted by Section 430-62.

## F. Motor Control Circuits

**430-71. General.** Part F contains modifications of the general requirements and applies to the particular conditions of motor control circuits.

(FPN): See Section 430-9(b).

**Definition of Motor Control Circuit:** The circuit of a control apparatus or system that carries the electric signals directing the performance of the controller, but does not carry the main power current.

### 430-72. Overcurrent Protection.

**(a) General.** A motor control circuit tapped from the load side of a motor branch-circuit short-circuit and ground-fault protective device(s) and functioning to control the motor(s) connected to that branch circuit shall be protected against overcurrent in accordance with Section 430-72. Such a tapped control circuit shall not be considered to be a branch circuit and shall be permitted to be protected by either a supplementary or branch-circuit overcurrent protective device(s). A motor control circuit other than such a tapped control circuit shall be protected against overcurrent in accordance with Section 725-12 or 725-35, as applicable.

**(b) Conductor Protection.** The overcurrent protection for conductors shall not exceed the values specified in Column A of Table 430-72(b).

*Exception No. 1: Conductors which do not extend beyond the motor control equipment enclosure shall require only short-circuit and ground-fault protection and shall be permitted to be protected by the motor branch-circuit short-circuit and ground-fault protective device(s) where the rating of the protective device(s) is not over the value specified in Column B of Table 430-72(b).*

*Exception No. 2: Conductors which extend beyond the motor control equipment enclosure shall require only short-circuit and ground-fault protection and shall be permitted to be protected by the motor branch-circuit short-circuit and ground-fault protective device(s) where the rating of the protective device(s) is not over the value specified in Column C of Table 430-72(b).*

*Exception No. 3: Conductors supplied by the secondary side of a single-phase transformer having only a two-wire (single-voltage) secondary shall be permitted to be protected by overcurrent protection provided on the primary (supply) side of the transformer, provided this protection does not exceed the value determined by multiplying the appropriate maximum rating of the overcurrent device for the secondary conductor from Table 430-72(b) by the secondary-to-primary voltage ratio. Transformer secondary conductors (other than two-wire) are not considered to be protected by the primary overcurrent protection.*

*Exception No. 4: Conductors of control circuits shall require only short-circuit and ground-fault protection and shall be permitted to be protected by the motor branch-circuit short-circuit and ground-fault protective device(s) where the opening of the control circuit would create a hazard as, for example, the control circuit of a fire pump motor, and the like.*

**Table 430-72(b). Maximum Rating of Overcurrent Protective Device-Amperes**

Control Circuit Conductor Size, AWG	Column A Basic Rule		Column B Exception No. 1.		Column C Exception No. 2	
	Copper	Alum. or Copper-Clad Alum.	Copper	Alum. or Copper-Clad Alum.	Copper	Alum. or Copper-Clad Alum.
18	7	—	25	—	7	—
16	10	—	40	—	10	—
14	Note 1	—	100	—	45	—
12	Note 1	Note 1	120	100	60	45
10	Note 1	Note 1	160	140	90	75
larger than 10	Note 1	Note 1	Note 2	Note 2	Note 3.	Note 3

Note 1: Value specified in Tables 310-16 through 310-31, as applicable.

Note 2: 400 percent of value specified in Table 310-17 for 60°C conductors.

Note 3: 300 percent of value specified in Table 310-16 for 60°C conductors:

**(c) Control Circuit Transformer.** Where a motor control circuit transformer is provided, the transformer shall be protected in accordance with Article 450.

*Exception No. 1: Control circuit transformers rated less than 50 VA and an integral part of the motor controller and located within the motor controller enclosure.*

*Exception No. 2: Where the control circuit transformer rated primary current is less than 2 amperes, an overcurrent device rated or set at not more than 500 percent of the rated primary current shall be permitted in the primary circuit.*

*Exception No. 3: Where the transformer supplies a Class 1 power-limited, circuit [see Section 725-11(a)] Class 2, or Class 3 remote control circuit conforming with the requirements of Article 725 (see Article 725 Part C).*

*Exception No. 4: Where protection is provided by other approved means.*

*Exception No. 5: Overcurrent protection shall be omitted where the opening of the control circuit would create a hazard, as, for example, the control circuit of a fire pump motor and the like.*

**430-73. Mechanical Protection of Conductor.** Where damage to a motor control circuit would constitute a hazard, all conductors of such a remote motor control circuit that are outside the control device itself shall be installed in a raceway or be otherwise suitably protected from physical damage.

Where one side of the motor control circuit is grounded, the motor control circuit shall be so arranged that an accidental ground in the remote-control devices will not start the motor.

**430-74. Disconnection.**

(a) **General.** Motor control circuits shall be so arranged that they will be disconnected from all sources of supply when the disconnecting means is in the open position. The disconnecting means shall be permitted to consist of two or more separate devices, one of which disconnects the motor and the controller from the source(s) of power supply for the motor, and the other(s), the motor control circuit(s) from its power supply. Where separate devices are used, they shall be located immediately adjacent one to each other.

*Exception No. 1: Where more than twelve motor control circuit conductors are required to be disconnected, the disconnecting means shall be permitted to be located other than immediately adjacent one to each other where all of the following conditions are complied with:*

a. Access to live parts is limited to qualified persons in accordance with Part K of this article.

b. A warning sign is permanently located on the outside of each equipment enclosure door or cover permitting access to the live parts in the motor control circuit(s), warning that motor control circuit disconnecting means are remotely located and specifying the location and identification of each disconnect. Where live parts are not in an equipment enclosure as permitted by Sections 430-132 and 430-133, an additional warning sign(s) shall be located where visible to persons who may be working in the area of the live parts.

*Exception No. 2: Where the opening of one or more motor control circuit disconnect means may result in potentially unsafe conditions for personnel or property and the conditions a. and b. of Exception No. 1 above are complied with.*

(b) **Control Transformer in Controller.** Where a transformer or other device is used to obtain a reduced voltage for the motor control circuit and is located in the controller, such transformer or other device shall be connected to the load side of the disconnecting means for the motor control circuit.

### G. Motor Controllers

**430-81. General.** Part G is intended to require suitable controllers for all motors.

(a) **Definition.** For definition of "Controller," see Article 100. For the purpose of this article, a controller is any switch or device normally used to start and stop a motor by making and breaking the motor circuit current.

(b) **Stationary Motor of  $\frac{1}{8}$  Horsepower or Less.** For a stationary motor rated at  $\frac{1}{8}$  horsepower or less that is normally left running and is so constructed that it cannot be damaged by overload or failure to start, such as clock motors and the like, the branch-circuit protective device shall be permitted to serve as the controller.

(c) **Portable Motor of  $\frac{1}{3}$  Horsepower or Less.** For a portable motor rated at  $\frac{1}{3}$  horsepower or less, the controller shall be permitted to be an attachment plug and receptacle.

#### 430-82. Controller Design.

(a) **Starting and Stopping.** Each controller shall be capable of starting and stopping the motor it controls, and shall be capable of interrupting the stalled-rotor current of the motor.

(b) **Autotransformer.** An autotransformer starter shall provide an "off" position, a running position, and at least one starting position. It shall be so designed that it cannot rest in the starting position or in any position that will render the overload device in the circuit inoperative.

(c) **Rheostats.** Rheostats shall be in compliance with the following:

(1) Motor-starting rheostats shall be so designed that the contact arm cannot be left on intermediate segments. The point or plate on which the arm rests when in the starting position shall have no electrical connection with the resistor.

(2) Motor-starting rheostats for direct-current motors operated from a constant voltage supply shall be equipped with automatic devices that will interrupt the supply before the speed of the motor has fallen to less than one-third its normal value.

**430-83. Rating.** The controller shall have a horsepower rating not lower than the horsepower rating of the motor.

*Exception No. 1: For a stationary motor rated at 2 horsepower or less, and 300 volts or less, the controller shall be permitted to be a general-use switch having an ampere rating not less than twice the full-load current rating of the motor.*

*On ac circuits, general-use snap switches suitable only for use on ac (not general-use ac-dc snap switches) shall be permitted to control a motor rated at 2 horsepower or less and 300 volts or less having a full-load current rating not more than 80 percent of the ampere rating of the switch.*

*Exception No. 2: A branch-circuit inverse time circuit breaker rated in amperes only shall be permitted as a controller. Where this circuit breaker is also used for overload protection, it shall conform to the appropriate provisions of this article governing overload protection.*

*Exception No. 3: The motor controller for a torque motor shall have a continuous-duty, full-load current rating not less than the nameplate current*

rating of the motor. For a motor controller rated in horsepower but not marked with the foregoing current rating, the equivalent current rating shall be determined from the horsepower rating by using Tables 430-147, 430-148, 430-149, or 430-150.

**430-84. Need Not Open All Conductors.** The controller shall not be required to open all conductors to the motor.

*Exception: Where the controller serves also as a disconnecting means, it shall open all ungrounded conductors to the motor as provided in Section 430-111.*

**430-85. In Grounded Conductors.** One pole of the controller shall be permitted to be placed in a permanently grounded conductor, provided the controller is so designed that the pole in the grounded conductor cannot be opened without simultaneously opening all conductors of the circuit.

**430-87. Number of Motors Served by Each Controller.** Each motor shall be provided with an individual controller.

*Exception: For motors rated 600 volts or less, a single controller rated at not less than the sum of the horsepower ratings of all of the motors of the group shall be permitted to serve the group of motors under any one of the following conditions:*

a. *Where a number of motors drive several parts of a single machine or piece of apparatus, such as metal and woodworking machines, cranes, hoists, and similar apparatus.*

b. *Where a group of motors is under the protection of one overcurrent device as permitted in Section 430-53(a).*

c. *Where a group of motors is located in a single room within sight from the controller location.*

**430-88. Adjustable-Speed Motors.** Adjustable-speed motors that are controlled by means of field regulation shall be so equipped and connected that they cannot be started under weakened field.

*Exception: Where the motor is designed for such starting.*

**430-89. Speed Limitation.** Machines of the following types shall be provided with speed limiting devices or other speed limiting means:

(a) **Separately Excited DC Motors.** Separately excited direct-current motors.

(b) **Series Motors.** Series motors.

(c) **Motor-Generators and Converters.** Motor-generators and converters that can be driven at excessive speed from the direct-current end, as by a reversal of current or decrease in load.

*Exception No. 1: When the inherent characteristics of the machines, the system, or the load and the mechanical connection thereto are such as to safely limit the speed.*

*Exception No. 2: When the machine is always under the manual control of a qualified operator.*

**430-90. Combination Fuseholder and Switch as Controller.** The rating of a combination fuseholder and switch used as a motor controller shall be such

that the fuseholder will accommodate the size of the fuse specified in Part C of this article for motor overload protection.

*Exception: Where fuses having time delay appropriate for the starting characteristics of the motor are used, fuseholders of smaller size than specified in Part C of this article shall be permitted.*

**430-91: Motor Controller Enclosure Types.** Table 430-91 provides the basis for selecting enclosures for use in specific nonhazardous locations. The enclosures are not intended to protect against conditions such as condensation, icing, corrosion or contamination which may occur within the enclosure or enter via the conduit or unsealed openings. These internal conditions require special consideration by the installer and/or user.

**Table 430-91. Motor Controller Enclosure Selection Table**

Provides a Degree of Protection Against the Following Environmental Conditions	For Outdoor Use						
	Enclosure Type Number†						
	3	3R	3S	4	4X	6	6P
Incidental contact with the enclosed equipment	X	X	X	X	X	X	X
Rain, snow and sleet	X	X	X	X	X	X	X
Sleet*	—	—	X	—	—	—	—
Windblown dust	X	—	X	X	X	X	X
Hosedown	—	—	—	X	X	X	X
Corrosive agents	—	—	—	—	X	—	X
Occasional temporary submersion	—	—	—	—	—	X	X
Occasional prolonged submersion	—	—	—	—	—	—	X

\* Mechanism shall be operable when ice covered.

Provides a Degree of Protection Against the Following Environmental Conditions	For Indoor Use										
	Enclosure Type Number†										
	1	2	4	4X	5	6	6P	11	12	12K	13
Incidental contact with the enclosed equipment	X	X	X	X	X	X	X	X	X	X	X
Falling dirt	X	X	X	X	X	X	X	X	X	X	X
Falling liquids and light splashing	—	X	X	X	—	X	X	X	X	X	X
Dust, lint, fibers and flyings	—	—	X	X	X	X	X	—	X	X	X
Hosedown and splashing water	—	—	X	X	—	X	X	—	—	—	—
Oil and coolant seepage	—	—	—	—	—	—	—	—	X	X	X
Oil or coolant spraying and splashing	—	—	—	—	—	—	—	—	—	—	X
Corrosive agents	—	—	—	X	—	—	X	X	—	—	—
Occasional temporary submersion	—	—	—	—	—	X	X	—	—	—	—
Occasional prolonged submersion	—	—	—	—	—	—	X	—	—	—	—

† Enclosure type number, except type number 1, shall be marked on the motor controller enclosure.



## H. Disconnecting Means

**430-101. General.** Part H is intended to require disconnecting means capable of disconnecting motors and controllers from the circuit.

(FPN): See Diagram 430-1.

(FPN): See Section 110-22 for identification of disconnecting means.

### **430-102. Location.**

**(a) Controller.** A disconnecting means shall be located in sight from the controller location.

*Exception No. 1: For motor circuits over 600 volts, nominal, the controller disconnecting means shall be permitted to be out of sight of the controller, provided the controller is marked with a warning label giving the location and identification of the disconnecting means to be locked in the open position.*

*Exception No. 2: A single disconnecting means shall be permitted to be located adjacent to a group of coordinated controllers mounted adjacent one to each other on a multimotor continuous process machine.*

**(b) Motor.** A disconnecting means shall be located in sight from the motor location and the driven machinery location.

*Exception: Where the disconnecting means provided in accordance with Section 430-102(a) is capable of being locked in the open position.*

**430-103. To Disconnect Both Motor and Controller.** The disconnecting means shall disconnect the motor and the controller from all ungrounded supply conductors and shall be so designed that no pole can be operated independently. The disconnecting means shall be permitted in the same enclosure with the controller.

(FPN): See Section 430-113 for equipment receiving energy from more than one source.

**430-104. To Be Indicating.** The disconnecting means shall plainly indicate whether it is in the open (off) or closed (on) position.

**430-105. Grounded Conductors.** One pole of the disconnecting means shall be permitted to disconnect a permanently grounded conductor, provided the disconnecting means is so designed that the pole in the grounded conductor cannot be opened without simultaneously disconnecting all conductors of the circuit.

**430-106. Service Switch as Disconnecting Means.** Where an installation consists of a single motor, the service switch may serve as the disconnecting means if it complies with this article and is within sight from the controller location.

**430-107. Readily Accessible.** One of the disconnecting means shall be readily accessible.

**430-108. Every Switch.** Every disconnecting means in the motor circuit between the point of attachment to the feeder and the point of connection to the motor shall comply with the requirements of Sections 430-109 and 430-110.

**430-109. Type.** The disconnecting means shall be a motor-circuit switch rated in horsepower, a circuit breaker, or a molded case switch (nonautomatic circuit interrupter).

*Exception No. 1: For stationary motors of 1/8 horsepower or less, the branch-circuit overcurrent device shall be permitted to serve as the disconnecting means.*

*Exception No. 2: For stationary motors rated at 2 horsepower or less and 300 volts or less; the disconnecting means shall be permitted to be a general-use switch having an ampere rating not less than twice the full-load current rating of the motor.*

*On ac circuits, general-use snap switches suitable only for use on ac (not general-use ac-dc snap switches) shall be permitted to disconnect a motor rated 2 horsepower or less and 300 volts or less having a full-load current rating not more than 80 percent of the ampere rating of the switch.*

*Exception No. 3: For motors of over 2 horsepower to and including 100 horsepower, the separate disconnecting means required for a motor with an autotransformer-type controller shall be permitted to be a general-use switch where all of the following provisions are met:*

*a. The motor drives a generator that is provided with overload protection.*

*b. The controller (1) is capable of interrupting the locked-rotor current of the motor; (2) is provided with a no-voltage release; and (3) is provided with running overload protection not exceeding 125 percent of the motor full-load current rating.*

*c. Separate fuses or an inverse time circuit breaker rated or set at not more than 150 percent of the motor full-load current are provided in the motor branch circuit.*

*Exception No. 4: For stationary motors rated at more than 40 horsepower direct-current or 100 horsepower alternating-current, the disconnecting means shall be permitted to be a general-use or isolating switch when plainly marked "Do not operate under load."*

*Exception No. 5: For a cord- and plug-connected motor, a horsepower-rated attachment plug and receptacle having ratings no less than the motor ratings shall be permitted to serve as the disconnecting means. A horsepower rated attachment plug and receptacle shall not be required for a cord- and plug-connected appliance in accordance with Section 422-22 or a room air conditioner in accordance with Section 440-63.*

*Exception No. 6: For torque motors the disconnecting means shall be permitted to be a general-use switch.*

**430-110. Ampere Rating and Interrupting Capacity.**

**(a) General.** The disconnecting means for motor circuits rated 600 volts, nominal, or less, shall have an ampere rating of at least 115 percent of the full-load current rating of the motor.

**(b) For Torque Motors.** Disconnecting means for a torque motor shall have an ampere rating of at least 115 percent of the motor nameplate current.

**(c) For Combination Loads.** Where two or more motors are used together or where one or more motors are used in combination with other loads, such as resistance heaters, and where the combined load may be simultaneous on

a single disconnecting means, the ampere and horsepower ratings of the combined load shall be determined as follows:

(1) The rating of the disconnecting means shall be determined from the summation of all currents, including resistance loads, at the full-load condition and also at the locked-rotor condition. The combined full-load current and the combined locked-rotor current so obtained shall be considered as a single motor for the purpose of this requirement as follows:

The full-load current equivalent to the horsepower rating of each motor shall be selected from Table 430-148, 430-149, or 430-150. These full-load currents shall be added to the rating in amperes of other loads to obtain an equivalent full-load current for the combined load.

The locked-rotor current equivalent to the horsepower rating of each motor shall be selected from Table 430-151. The locked-rotor currents shall be added to the rating in amperes of other loads to obtain an equivalent locked-rotor current for the combined load. Where two or more motors and/or other loads cannot be started simultaneously, appropriate combinations of locked-rotor and full-load current shall be permitted to be used to determine the equivalent locked-rotor current for the simultaneous combined loads.

*Exception: Where part of the concurrent load is resistance load, and where the disconnecting means is a switch rated in horsepower and amperes, the switch used shall be permitted to have a horsepower rating not less than the combined load of the motor(s), if the ampere rating of the switch is not less than the locked-rotor current of the motor(s) plus the resistance load.*

(2) The ampere rating of the disconnecting means shall not be less than 115 percent of the summation of all currents at the full-load condition determined in accordance with (c)(1) above.

(3) For small motors not covered by Tables 430-147, 430-148, 430-149, or 430-150, the locked-rotor current shall be assumed to be six times the full-load current.

**430-111. Switch or Circuit Breaker as Both Controller and Disconnecting Means.** A switch or circuit breaker complying with Section 430-83 shall be permitted to serve as both controller and disconnecting means if it opens all ungrounded conductors to the motor, if it is protected by an overcurrent device (which shall be permitted to be the branch-circuit fuses) that opens all ungrounded conductors to the switch or circuit breaker, and if it is of one of the following types:

(a) **Air-Break Switch.** An air-break switch, operable directly by applying the hand to a lever or handle.

(b) **Inverse Time Circuit Breaker.** An inverse time circuit breaker operable directly by applying the hand to a lever or handle.

(c) **Oil Switch.** An oil switch used on a circuit whose rating does not exceed 600 volts or 100 amperes, or by special permission on a circuit exceeding this capacity where under expert supervision.

The oil switch or circuit breaker specified above shall be permitted to be both power and manually operable.

The overcurrent device protecting the controller shall be permitted to be part of the controller assembly or shall be permitted to be separate.

An autotransformer-type controller shall be provided with a separate disconnecting means.

**430-112. Motors Served by Single Disconnecting Means.** Each motor shall be provided with an individual disconnecting means.

*Exception: A single disconnecting means shall be permitted to serve a group of motors under any one of the following conditions:*

*a. Where a number of motors drive several parts of a single machine or piece of apparatus, such as metal and woodworking machines, cranes, and hoists.*

*b. Where a group of motors is under the protection of one set of branch-circuit protective devices as permitted by Section 430-53(a).*

*c. Where a group of motors is in a single room within sight from the location of the disconnecting means.*

The single disconnecting means shall have a rating not less than is required by Section 430-110 for a single motor, the rating of which equals the sum of the horsepower or currents of all the motors of the group.

**430-113. Energy from More than One Source.** Motor and motor-operated equipment receiving electrical energy from more than one source shall be provided with disconnecting means from each source of electrical energy immediately adjacent to the equipment served. Each source shall be permitted to have a separate disconnecting means.

*Exception No. 1: Where a motor receives electrical energy from more than one source, the disconnecting means for the main power supply to the motor shall not be required to be immediately adjacent to the motor provided the controller disconnecting means is capable of being locked in the open position.*

*Exception No. 2: A separate disconnecting means shall not be required for a Class 2 remote-control circuit conforming with Article 725, rated not more than 30 volts, and which is isolated and ungrounded.*

## J. Over 600 Volts, Nominal

**430-121. General.** Part J recognizes the additional hazard due to the use of higher voltages. It adds to or amends the other provisions of this article. Other requirements for circuits and equipment operating at over 600 volts, nominal, are in Article 710.

**430-122. Marking on Controllers.** In addition to the marking required by Section 430-8, a controller shall be marked with the control voltage.

**430-123. Conductor Enclosures Adjacent to Motors.** Flexible metal conduit or liquidtight flexible metal conduit not exceeding 6 feet (1.83 m) in length shall be permitted to be employed for raceway connection to a motor terminal enclosure.

**430-124. Size of Conductors.** Conductors supplying motors shall have an ampacity not less than the current at which the motor overload protective device(s) is selected to trip.

**430-125. Motor Circuit Overcurrent Protection.**

(a) **General.** The high-voltage circuit for each motor shall include coordinated protection to automatically interrupt overload and fault currents in the motor, the motor circuit conductors, and the motor control apparatus.

*Exception: Where a motor is vital to operation of the plant and the motor should operate to failure if necessary to prevent a greater hazard to persons, the sensing device(s) is permitted to be connected to a supervised annunciator or alarm instead of interrupting the motor circuit.*

**(b) Overload Protection.**

(1) Each motor shall be protected against dangerous heating due to motor overloads and failure to start by a thermal protector integral with the motor or external current sensing devices, or both.

(2) The secondary circuits of wound-rotor alternating-current motors including conductors, controllers, and resistors rated for the application shall be considered as protected against overcurrent by the motor overload protection means.

(3) Operation of the overload interrupting device shall simultaneously disconnect all ungrounded conductors.

(4) Overload sensing devices shall not automatically reset after trip unless resetting of the overload sensing device does not cause automatic restarting of the motor or there is no hazard to persons created by automatic restarting of the motor and its connected machinery.

**(c) Fault-Current Protection.**

(1) Fault-current protection shall be provided in each motor circuit by one of the following means:

a. A circuit breaker of suitable type and rating so arranged that it can be serviced without hazard. The circuit breaker shall simultaneously disconnect all ungrounded conductors. The circuit breaker shall be permitted to sense the fault current by means of integral or external sensing elements.

b. Fuses of a suitable type and rating placed in each ungrounded conductor. Fuses shall be used with suitable disconnecting means or they shall be of a type that can also serve as the disconnecting means. They shall be so arranged that they cannot be serviced while they are energized.

(2) Fault-current interrupting devices shall not reclose the circuit automatically.

*Exception: Where circuits are exposed to transient faults and where automatic reclosing of the circuit does not create a hazard to persons.*

(3) Overload protection and fault-current protection shall be permitted to be provided by the same device.

**430-126. Rating of Motor Control Apparatus.** Motor controllers and motor branch-circuit disconnecting means shall have a continuous ampere rating not less than the current at which the overload protective device(s) is selected to trip.

**430-127. Disconnecting Means.** The controller disconnecting means shall be capable of being locked in the open position.

## **K. Protection of Live Parts — All Voltages**

**430-131. General.** Part K specifies that live parts shall be protected in a manner judged adequate to the hazard involved.

**430-132. Where Required.** Exposed live parts of motors and controllers operating at 50 volts or more between terminals shall be guarded against accidental contact by enclosure or by location as follows:

(a) **In a Room or Enclosure.** By installation in a room or enclosure that is accessible only to qualified persons.

(b) **On a Suitable Balcony.** By installation on a suitable balcony, gallery, or platform, so elevated and arranged as to exclude unqualified persons.

(c) **Elevation.** By elevation 8 feet (2.44 m) or more above the floor.

*Exception: Stationary motors having commutators, collectors, and brush rigging located inside of motor-end brackets and not conductively connected to supply circuits operating at more than 150 volts to ground.*

**430-133. Guards for Attendants.** Where live parts of motors or controllers operating at over 150 volts to ground are guarded against accidental contact only by location as specified in Section 430-132, and where adjustment or other attendance may be necessary during the operation of the apparatus, suitable insulating mats or platforms shall be provided so that the attendant cannot readily touch live parts unless standing on the mats or platforms.

(FPN): For working space, see Sections 110-16 and 110-34.

#### L. Grounding All Voltages

**430-141. General.** Part L specifies the grounding of motor and controller frames to prevent a voltage above ground in the event of accidental contact between live parts and frames. Insulation, isolation, or guarding are suitable alternatives to grounding of motors under certain conditions.

**430-142. Stationary Motors.** The frames of stationary motors shall be grounded under any of the following conditions: (1) where supplied by metal-enclosed wiring; (2) where in a wet location and not isolated or guarded; (3) if in a hazardous (classified) location as covered in Articles 500 through 517; (4) if the motor operates with any terminal at over 150 volts to ground.

Where the frame of the motor is not grounded, it shall be permanently and effectively insulated from the ground.

**430-143. Portable Motors.** The frames of portable motors that operate at over 150 volts to ground shall be guarded or grounded.

(FPN): See Section 250-45(d) for grounding of portable appliances in other than residential occupancies.

(FPN): See Section 250-59(b) for color of grounding conductor.

**430-144. Controllers.** Controller enclosures shall be grounded regardless of voltage. Controller enclosures shall have means for attachment of an equipment grounding conductor termination in accordance with Section 250-113.

*Exception No. 1: Enclosures attached to ungrounded portable equipment.*

*Exception No. 2: Lined covers of snap switches.*

**430-145. Method of Grounding.** Where required, grounding shall be done in the manner specified in Article 250.

(a) **Grounding Through Terminal Housings.** Where the wiring to fixed motors is metal-enclosed cable or in metal raceways, junction boxes to house

motor terminals shall be provided, and the armor of the cable or the metal raceways shall be connected to them in the manner specified in Article 250.

(FPN): See Section 430-12(e) for grounding connection means required at motor terminal housings.

**(b) Separation of Junction Box from Motor.** The junction box required by (a) above shall be permitted to be separated from the motor not more than 6 feet (1.83 m), provided the leads to the motor are Type AC cable or armored cord or are stranded leads enclosed in liquidtight flexible metal conduit, liquidtight flexible nonmetallic conduit, flexible metal conduit, intermediate metal conduit, rigid metal conduit or electrical metallic tubing not smaller than 3/8-inch electrical trade size, the armor or raceway being connected both to the motor and to the box. Where stranded leads are used, protected as specified above, they shall not be larger than No. 10, and shall comply with other requirements of this Code for conductors to be used in raceways.

**(c) Grounding of Controller Mounted Devices.** Instrument transformer secondaries and exposed noncurrent-carrying metal or other conductive parts or cases of instrument transformers, meters, instruments, and relays shall be grounded as specified in Sections 250-121 through 250-125.

### M. Tables

**Table 430-147. Full-Load Current in Amperes, Direct-Current Motors**

The following values of full-load currents\* are for motors running at base speed.

HP	Armature Voltage Rating*					
	90V	120V	180V	240V	500V	550V
1/4	4.0	3.1	2.0	1.6		
1/2	5.2	4.1	2.6	2.0		
3/4	6.8	5.4	3.4	2.7		
1	9.6	7.6	4.8	3.8		
1 1/2	12.2	9.5	6.1	4.7		
2		13.2	8.3	6.6		
3		17	10.8	8.5		
5		25	16	12.2		
7 1/2		40	27	20		
10		58		29	13.6	12.2
15		76		38	18	16
20				55	27	24
25				72	34	31
30				89	43	38
40				106	51	46
50				140	67	61
60				173	83	75
75				206	99	90
100				255	123	111
125				341	164	148
150				425	205	185
200				506	246	222
				675	330	294

\* These are average direct-current quantities.

**Table 430-148. Full-Load Currents in Amperes—  
Single-Phase Alternating-Current Motors**

The following values of full-load currents are for motors running at usual speeds and motors with normal torque characteristics. Motors built for especially low speeds or high torques may have higher full-load currents, and multispeed motors will have full-load current varying with speed, in which case the nameplate current ratings shall be used.

To obtain full-load currents of 208- and 200-volt motors, increase corresponding 230-volt motor full-load currents by 10 and 15 percent, respectively.

The voltages listed are rated motor voltages. The currents listed shall be permitted for system voltage ranges of 110 to 120 and 220 to 240.

HP	115V	230V
1/6	4.4	2.2
1/4	5.8	2.9
1/3	7.2	3.6
1/2	9.8	4.9
3/4	13.8	6.9
1	16	8
1 1/2	20	10
2	24	12
3	34	17
5	56	28
7 1/2	80	40
10	100	50



**Table 430-149. Full-Load Current  
Two-Phase Alternating-Current Motors (4-Wire)**

The following values of full-load current are for motors running at speeds usual for belted motors and motors with normal torque characteristics. Motors built for especially low speeds or high torques may require more running current, and multispeed motors will have full-load current varying with speed, in which case the nameplate current rating shall be used. Current in the common conductor of a 2-phase, 3-wire system will be 1.41 times the value given.

The voltages listed are rated motor voltages. The currents listed shall be permitted for system voltage ranges of 110 to 120, 220 to 240, 440 to 480, and 550 to 600 volts.

HP	Induction Type Squirrel-Cage and Wound-Rotor Amperes				
	115V	230V	460V	575V	2300V
1/2	4	2	1	.8	
3/4	4.8	2.4	1.2	1.0	
1	6.4	3.2	1.6	1.3	
1 1/2	9	4.5	2.3	1.8	
2	11.8	5.9	3	2.4	
3		8.3	4.2	3.3	
5		13.2	6.6	5.3	
7 1/2		19	9	8	
10		24	12	10	
15		36	18	14	
20		47	23	19	
25		59	29	24	
30		69	35	28	
40		90	45	36	
50		113	56	45	
60		133	67	53	14
75		166	83	66	18
100		218	109	87	23
125		270	135	108	28
150		312	156	125	32
200		416	208	167	43

**Table 430-150. Full-Load Current\*  
Three-Phase Alternating-Current Motors**

HP	Induction Type Squirrel-Cage and Wound-Rotor Amperes					Synchronous Type †Unity Power Factor Amperes			
	115V	230V	460V	575V	2300V	230V	460V	575V	2300V
½	4	2	1	.8					
¾	5.6	2.8	1.4	1.1					
1	7.2	3.6	1.8	1.4					
1½	10.4	5.2	2.6	2.1					
2	13.6	6.8	3.4	2.7					
3		9.6	4.8	3.9					
5		15.2	7.6	6.1					
7½		22	11	9					
10		28	14	11					
15		42	21	17					
20		54	27	22					
25		68	34	27		53	26	21	
30		80	40	32		63	32	26	
40		104	52	41		83	41	33	
50		130	65	52		104	52	42	
60		154	77	62	16	123	61	49	12
75		192	96	77	20	155	78	62	15
100		248	124	99	26	202	101	81	20
125		312	156	125	31	253	126	101	25
150		360	180	144	37	302	151	121	30
200		480	240	192	49	400	201	161	40

For full-load currents of 208- and 200-volt motors, increase the corresponding 230-volt motor full-load current by 10 and 15 percent, respectively.

\* These values of full-load current are for motors running at speeds usual for belted motors and motors with normal torque characteristics. Motors built for especially low speeds or high torques may require more running current, and multispeed motors will have full-load current varying with speed, in which case the nameplate current rating shall be used.

† For 90 and 80 percent power factor the above figures shall be multiplied by 1.1 and 1.25 respectively.

The voltages listed are rated motor voltages. The currents listed shall be permitted for system voltage ranges of 110 to 120, 220 to 240, 440 to 480, and 550 to 600 volts.

**Table 430-151. Conversion Table of Locked-Rotor Currents  
for Selection of Disconnecting Means and Controllers  
as Determined from Horsepower and Voltage Rating**  
For use only with Sections 430-110, 440-12 and 440-41.

Motor Locked-Rotor Current Amperes*							Max. HP Rating
Single Phase		Two or Three Phase					
115V	230V	115V	200V	230V	460V	575V	
58.8	29.4	24	18.8	12	6	4.8	½
82.8	41.4	33.6	19.3	16.8	8.4	6.6	¾
96	48	43.2	24.8	21.6	10.8	8.4	1
120	60	62	35.9	31.2	15.6	12.6	1½
144	72	81	46.9	40.8	20.4	16.2	2
204	102	—	66.	58	26.8	23.4	3
336	168	—	105	91	45.6	36.6	5
480	240	—	152	132	66	54	7½
600	300	—	193	168	84	66	10
—	—	—	290	252	126	102	15
—	—	—	373	324	162	132	20
—	—	—	469	408	204	162	25
—	—	—	552	480	240	192	30
—	—	—	718	624	312	246	40
—	—	—	897	780	390	312	50
—	—	—	1063	924	462	372	60
—	—	—	1325	1152	576	462	75
—	—	—	1711	1488	744	594	100
—	—	—	2153	1872	936	750	125
—	—	—	2484	2160	1080	864	150
—	—	—	3312	2880	1440	1152	200

\* These values of motor locked-rotor current are approximately six times the full-load current values given in Tables 430-148 and 430-150.

**Table 430-152. Maximum Rating or Setting of Motor Branch-Circuit Short-Circuit and Ground-Fault Protective Devices**

Type of Motor	Percent of Full-Load Current			
	Nontime Delay Fuse	Dual Element (Time-Delay) Fuse	Instantaneous Trip Breaker	* Inverse Time Breaker
Single-phase, all types				
No code letter .....	300	175	700	250
All ac single-phase and polyphase squirrel-cage and synchronous motors† with full-voltage, resistor or reactor starting:				
No code letter .....	300	175	700	250
Code letter F to V .....	300	175	700	250
Code letter B to E .....	250	175	700	200
Code letter A .....	150	150	700	150
All ac squirrel-cage and synchronous motors† with autotransformer starting:				
Not more than 30 amps				
No code letter .....	250	175	700	200
More than 30 amps				
No code letter .....	200	175	700	200
Code letter F to V .....	250	175	700	200
Code letter B to E .....	200	175	700	200
Code letter A .....	150	150	700	150
High-reactance squirrel-cage				
Not more than 30 amps				
No code letter .....	250	175	700	250
More than 30 amps				
No code letter .....	200	175	700	200
Wound-rotor —				
No code letter .....	150	150	700	150
Direct-current (constant voltage)				
No more than 50 hp				
No code letter .....	150	150	250	150
More than 50 hp				
No code letter .....	150	150	175	150

For explanation of Code Letter Marking, see Table 430-7(b).

For certain exceptions to the values specified, see Sections 430-52 through 430-54.

\* The values given in the last column also cover the ratings of nonadjustable inverse time types of circuit breakers that may be modified as in Section 430-52.

† Synchronous motors of the low-torque, low-speed type (usually 450 rpm or lower), such as are used to drive reciprocating compressors, pumps, etc. that start unloaded, do not require a fuse rating or circuit-breaker setting in excess of 200 percent of full-load current.

## ARTICLE 440 — AIR-CONDITIONING AND REFRIGERATING EQUIPMENT

### A. General

**440-1. Scope.** The provisions of this article apply to electric motor-driven air-conditioning and refrigerating equipment, and to the branch circuits and controllers for such equipment. It provides for the special considerations necessary for circuits supplying hermetic refrigerant motor-compressors and for any air-conditioning and/or refrigerating equipment which is supplied from an individual branch circuit which supplies a hermetic refrigerant motor-compressor.

#### 440-2. Definitions.

**Hermetic Refrigerant Motor-Compressor:** A combination consisting of a compressor and motor, both of which are enclosed in the same housing, with no external shaft or shaft seals, the motor operating in the refrigerant.

#### 440-3. Other Articles.

(a) **Article 430.** These provisions are in addition to, or amendatory of, the provisions of Article 430 and other articles in this Code, which apply except as modified in this article.

(b) **Article 422, 424, or 430.** The rules of Article 422, 424, or 430, as applicable, shall apply to air-conditioning and refrigerating equipment which does not incorporate a hermetic refrigerant motor-compressor. Examples of such equipment are devices which employ refrigeration compressors driven by conventional motors, furnaces with air-conditioning evaporator coils installed, fan-coil units, remote forced air-cooled condensers, remote commercial refrigerators, etc.

(c) **Article 422.** Devices such as room air conditioners, household refrigerators and freezers, drinking water coolers, and beverage dispensers shall be considered appliances and the provisions of Article 422 shall also apply.

(d) **Other Applicable Articles.** Hermetic refrigerant motor-compressors, circuits, controllers, and equipment shall also comply with the applicable provisions of the following:

Capacitors .....	Section 460-9
Garages, Aircraft Hangars, Gasoline Dispensing and Service Stations, Bulk Storage Plants, Spray Application, Dipping and Coating Processes, Inhalation Anesthetizing Locations .....	Articles 511, 513, 514, 515, 516, and 517-G
Hazardous (Classified) Locations .....	Articles 500 through 503
Motion-Picture and Television Studios .....	Article 530
Resistors and Reactors .....	Article 470

#### 440-4. Marking on Hermetic Refrigerant Motor-Compressors and Equipment.

(a) **Hermetic Refrigerant Motor-Compressor Nameplate.** A hermetic refrigerant motor-compressor shall be provided with a nameplate which shall give the manufacturer's name, trademark or symbol; identifying designation; phase; voltage; and frequency. The rated load current in amperes of the motor-compressor shall be marked by the equipment manufacturer on either

or both the motor-compressor nameplate and the nameplate of the equipment in which the motor-compressor is used. The locked-rotor current of each single-phase motor-compressor having a rated-load current of more than 9 amperes at 115 volts or more than 4.5 amperes at 230 volts and each polyphase motor-compressor shall be marked on the motor-compressor nameplate. Where a thermal protector complying with Section 440-52(a)(2) and (b)(2) is used, the motor-compressor nameplate or the equipment nameplate shall be marked with the words, "Thermally Protected." Where a protective system, complying with Section 440-52(a)(4) and (b)(4), is used and is furnished with the equipment, the equipment nameplate shall be marked with the words, "Thermally Protected System." Where a protective system complying with Section 440-52(a)(4) and (b)(4) is specified, the equipment nameplate shall be appropriately marked.

(FPN): Definition: The rated-load current for a hermetic refrigerant motor-compressor is the current resulting when the motor-compressor is operated at the rated load, rated voltage and rated frequency of the equipment it serves.

**(b) Multimotor and Combination-Load Equipment.** Multimotor and combination-load equipment shall be provided with a visible nameplate marked with the maker's name, the rating in volts, frequency and number of phases, minimum supply circuit conductor ampacity, and the maximum rating of the branch-circuit short-circuit and ground-fault protective device. The ampacity shall be calculated by using Part D and counting all the motors and other loads which will be operated at the same time. The branch-circuit short-circuit and ground-fault protective device rating shall not exceed the value calculated by using Part C. Multimotor or combination-load equipment for use on two or more circuits shall be marked with the above information for each circuit.

*Exception No. 1: Multimotor and combination-load equipment which is suitable under the provisions of this article for connection to a single 15- or 20-ampere, 120-volt, or a 15-ampere, 208- or 240-volt single-phase branch circuit shall be permitted to be marked as a single load.*

*Exception No. 2: Room air conditioners as provided in Part G of Article 440.*

**(c) Branch-Circuit Selection Current.** Hermetic refrigerant motor-compressors or equipment containing such compressor(s) in which the protection system, approved for use with the motor-compressor which it protects, permits continuous current in excess of the specified percentage of nameplate rated-load current given in Section 440-52(b)(2) or (b)(4) shall also be marked with a branch-circuit selection current that complies with Section 440-52(b)(2) or (b)(4). This marking shall be provided by the equipment manufacturer and shall be on the nameplate(s) where the rated-load current(s) appears.

(FPN): Definition: Branch-circuit selection current is the value in amperes to be used instead of the rated-load current in determining the ratings of motor branch-circuit conductors, disconnecting means, controllers and branch-circuit short-circuit and ground-fault protective devices wherever the running overload protective device permits a sustained current greater than the specified percentage of the rated-load current. The value of branch-circuit selection current will always be equal to or greater than the marked rated-load current.

**440-5. Marking on Controllers.** A controller shall be marked with the maker's name, trademark, or symbol; identifying designation; the voltage; phase; full-load and locked-rotor current (or horsepower) rating; and such

other data as may be needed to properly indicate the motor-compressor for which it is suitable.

**440-6. Ampacity and Rating.** Conductors for equipment covered by this article shall be selected from Tables 310-16 through 310-31 as applicable. The required ampacity of conductors and rating of equipment shall be determined as follows.

**(a) Hermetic Refrigerant Motor-Compressor.** For a hermetic refrigerant motor-compressor, the rated-load current marked on the nameplate of the equipment in which the motor-compressor is employed shall be used in determining the rating or ampacity of the disconnecting means, the branch-circuit conductors, the controller, the branch-circuit short-circuit and ground-fault protection, and the separate motor overload protection. Where no rated-load current is shown on the equipment nameplate, the rated-load current shown on the compressor nameplate shall be used. For disconnecting means and controllers, see also Sections 440-12 and 440-41.

*Exception No. 1: When so marked, the branch-circuit selection current shall be used instead of the rated-load current to determine the rating or ampacity of the disconnecting means, the branch-circuit conductors, the controller, and the branch-circuit short-circuit and ground-fault protection.*

*Exception No. 2: As permitted in Section 440-22(b) for branch-circuit short-circuit and ground-fault protection of cord- and plug-connected equipment.*

**(b) Multimotor Equipment.** For multimotor equipment employing a shaded-pole or permanent split-capacitor-type fan or blower motor, the full-load current for such motor marked on the nameplate of the equipment in which the fan or blower motor is employed shall be used instead of the horsepower rating to determine the ampacity or rating of the disconnecting means, the branch-circuit conductors, the controller, the branch-circuit short-circuit and ground-fault protection, and the separate overload protection. This marking on the equipment nameplate shall not be less than the current marked on the fan or blower motor nameplate.

**440-7. Highest Rated (Largest) Motor.** In determining compliance with this article and with Sections 430-24, 430-53(b) and (c), and 430-62(a), the highest rated (largest) motor shall be considered to be that motor which has the highest rated-load current. Where two or more motors have the same rated-load current, only one of them shall be considered as the highest rated (largest) motor. For other than hermetic refrigerant motor-compressors, and fan or blower motors as covered in Section 440-6(b), the full-load current used to determine the highest rated motor shall be the equivalent value corresponding to the motor horsepower rating selected from Tables 430-148, 430-149, or 430-150.

*Exception: When so marked, the branch-circuit selection current shall be used instead of the rated-load current in determining the highest rated (largest) motor-compressor.*

**440-8. Single Machine.** An air-conditioning or refrigerating system shall be considered to be a single machine under the provisions of Section 430-87, Exception and Section 430-112, Exception. The motors shall be permitted to be located remotely from each other.

## B. Disconnecting Means

**440-11. General.** The provisions of Part B are intended to require disconnecting means capable of disconnecting air-conditioning and refrigerating equipment including motor-compressors, and controllers, from the circuit feeder. See Diagram 430-1.

### 440-12. Rating and Interrupting Capacity.

(a) **Hermetic Refrigerant Motor-Compressor.** A disconnecting means serving a hermetic refrigerant motor-compressor shall be selected on the basis of the nameplate rated-load current or branch-circuit selection current, whichever is greater, and locked-rotor current, respectively, of the motor-compressor as follows:

(1) The ampere rating shall be at least 115 percent of the nameplate rated-load current or branch-circuit selection current; whichever is greater.

(2) To determine the equivalent horsepower in complying with the requirements of Section 430-109, the horsepower rating shall be selected from Tables 430-148, 430-149, or 430-150 corresponding to the rated-load current or branch-circuit selection current, whichever is greater, and also the horsepower rating from Table 430-151 corresponding to the locked-rotor current. In case the nameplate rated-load current or branch-circuit selection current and locked-rotor current do not correspond to the currents shown in Tables 430-148, 430-149, 430-150, or 430-151, the horsepower rating corresponding to the next higher value shall be selected. In case different horsepower ratings are obtained when applying these tables, a horsepower rating at least equal to the larger of the values obtained shall be selected.

(b) **Combination Loads.** Where one or more hermetic refrigerant motor-compressors are used together or are used in combination with other motors and/or loads such as resistance heaters and where the combined load may be simultaneous on a single disconnecting means, the rating for the combined load shall be determined as follows:

(1) The horsepower rating of the disconnecting means shall be determined from the summation of all currents, including resistance loads, at the rated-load condition and also at the locked-rotor condition: The combined rated-load current and the combined locked-rotor current so obtained shall be considered as a single motor for the purpose of this requirement as follows:

a. The full-load current equivalent to the horsepower rating of each motor, other than a hermetic refrigerant motor-compressor, and fan or blower motors as covered in Section 440-6(b) shall be selected from Tables 430-148, 430-149, or 430-150. These full-load currents shall be added to the motor-compressor rated-load current(s) or branch-circuit selection current(s), whichever is greater, and to the rating in amperes of other loads to obtain an equivalent full-load current for the combined load.

b. The locked-rotor current equivalent to the horsepower rating of each motor, other than a hermetic refrigerant motor-compressor, shall be selected from Table 430-151, and for fan and blower motors of the shaded-pole or permanent split-capacitor type marked with the locked-rotor current, the marked value shall be used. The locked-rotor currents shall be added to the motor-compressor locked-rotor current(s) and to the rating in amperes of other loads to obtain an equivalent locked-rotor current for the combined



load. Where two or more motors and/or other loads cannot be started simultaneously, appropriate combinations of locked-rotor and rated-load current or branch-circuit selection current, whichever is greater, shall be an acceptable means of determining the equivalent locked-rotor current for the simultaneous combined load.

*Exception: Where part of the concurrent load is a resistance load and the disconnecting means is a switch rated in horsepower and amperes, the switch used shall be permitted to have a horsepower rating not less than the combined load to the motor-compressor(s) and other motor(s) at the locked-rotor condition, if the ampere rating of the switch is not less than this locked-rotor load plus the resistance load.*

(2) The ampere rating of the disconnecting means shall be at least 115 percent of the summation of all currents at the rated-load condition determined in accordance with Section 440-12(b)(1).

(c) **Small Motor-Compressors.** For small motor-compressors not having the locked-rotor current marked on the nameplate, or for small motors not covered by Tables 430-147, 430-148, 430-149, or 430-150, the locked-rotor current shall be assumed to be six times the rated-load current. See Section 440-3(a).

(d) **Every Switch.** Every disconnecting means in the refrigerant motor-compressor circuit between the point of attachment to the feeder and the point of connection to the refrigerant motor-compressor shall comply with the requirements of Section 440-12.

(e) **Disconnecting Means Rated in Excess of 100 Horsepower.** Where the rated-load or locked-rotor current as determined above would indicate a disconnecting means rated in excess of 100 horsepower, the provisions of Section 430-109, Exception No. 4 shall apply.

**440-13. Cord-Connected Equipment.** For cord-connected equipment such as room air conditioners, household refrigerators and freezers, drinking water coolers, and beverage dispensers, a separable connector or an attachment plug and receptacle shall be permitted to serve as the disconnecting means. See also Section 440-63.

**440-14. Location.** Disconnecting means shall be located within sight from and readily accessible from the air-conditioning or refrigerating equipment. The disconnecting means shall be permitted to be installed on or within the air-conditioning or refrigerating equipment.

*Exception: Cord- and plug-connected appliances.*

(FPN): See Parts G and H of Article 430 for additional requirements.

### C. Branch-Circuit Short-Circuit and Ground-Fault Protection

**440-21. General.** The provisions of Part C specify devices intended to protect the branch-circuit conductors, control apparatus and motors in circuits supplying hermetic refrigerant motor-compressors against overcurrent due to short circuits and grounds. They are in addition to or amendatory of the provisions of Article 240.

**440-22. Application and Selection.**

(a) **Rating or Setting for Individual Motor-Compressor.** The motor-compressor branch-circuit short-circuit and ground-fault protective device shall be capable of carrying the starting current of the motor. A protective device having a rating or setting not exceeding 175 percent of the motor-compressor rated-load current or branch-circuit selection current, whichever is greater, shall be permitted, provided that where the protection specified is not sufficient for the starting current of the motor, the rating or setting shall be permitted to be increased, but shall not exceed 225 percent of the motor-rated-load current or branch-circuit selection current, whichever is greater.

*Exception: The rating of the branch-circuit short-circuit and ground-fault protective device shall not be required to be less than 15 amperes.*

(b) **Rating or Setting for Equipment.** The equipment branch-circuit short-circuit and ground-fault protective device shall be capable of carrying the starting current of the equipment. Where the hermetic refrigerant motor-compressor is the only load on the circuit, the protection shall conform with Section 440-22(a). Where the equipment incorporates more than one hermetic refrigerant motor-compressor or a hermetic refrigerant motor-compressor and other motors or other loads, the equipment short-circuit and ground-fault protection shall conform with Section 430-53 and the following:

(1) Where a hermetic refrigerant motor-compressor is the largest load connected to the circuit, the rating or setting of the branch-circuit short-circuit and ground-fault protective device shall not exceed the value specified in Section 440-22(a) for the largest motor-compressor plus the sum of the rated-load current or branch-circuit selection current, whichever is greater, of the other motor-compressor(s) and the ratings of the other loads supplied.

(2) Where a hermetic refrigerant motor-compressor is not the largest load connected to the circuit, the rating or setting of the branch-circuit short-circuit and ground-fault protective device shall not exceed a value equal to the sum of the rated-load current or branch-circuit selection current, whichever is greater, rating(s) for the motor-compressor(s) plus the value specified in Section 430-53(c)(4) where other motor loads are supplied, or the value specified in Section 240-3 where only nonmotor loads are supplied in addition to the motor-compressor(s).

*Exception No. 1: Equipment which will start and operate on a 15- or 20-ampere 120-volt, or 15-ampere 208- or 240-volt single-phase branch circuit shall be permitted to be protected by the 15- or 20-ampere overcurrent device protecting the branch circuit, but if the maximum branch-circuit short-circuit and ground-fault protective device rating marked on the equipment is less than these values, the circuit protective device shall not exceed the value marked on the equipment nameplate.*

*Exception No. 2: The nameplate marking of cord- and plug-connected equipment rated not greater than 250 volts, single-phase, such as household refrigerators and freezers, drinking water coolers, and beverage dispensers, shall be used in determining the branch-circuit requirements, and each unit shall be considered as a single motor unless the nameplate is marked otherwise.*

(c) **Protective Device Rating Not to Exceed the Manufacturer's Values:** Where maximum protective device ratings shown on a manufacturer's heater table for use with a motor controller are less than the rating or setting

selected in accordance with Section 440-22(a) and (b), the protective device rating shall not exceed the manufacturer's values marked on the equipment.

#### D. Branch-Circuit Conductors

**440-31. General.** The provisions of Part D and Articles 300 and 310 specify sizes of conductors required to carry the motor current without overheating under the conditions specified, except as modified in Section 440-6(a), Exception No. 1.

The provisions of these articles shall not apply to integral conductors of motors, motor controllers and the like, or to conductors which form an integral part of approved equipment.

(FPN): See Sections 300-1(b) and 310-1 for similar requirements.

**440-32. Single Motor-Compressor.** Branch-circuit conductors supplying a single motor-compressor shall have an ampacity not less than 125 percent of either the motor-compressor rated-load current or the branch-circuit selection current, whichever is greater.

**440-33. Motor-Compressor(s) With or Without Additional Motor Loads.** Conductors supplying one or more motor-compressor(s) with or without additional load(s) shall have an ampacity not less than the sum of the rated-load or branch-circuit selection current ratings, whichever is larger, of all the motor-compressor(s) plus the full-load currents of the other motor(s), plus 25 percent of the highest motor or motor-compressor rating in the group.

*Exception No. 1: When the circuitry is so interlocked as to prevent the starting and running of a second motor-compressor or group of motor-compressors, the conductor size shall be determined from the largest motor-compressor or group of motor-compressors that is to be operated at a given time.*

*Exception No. 2: Room air conditioners as provided in Part G of Article 440.*

**440-34. Combination Load.** Conductors supplying a motor-compressor load in addition to a lighting or appliance load as computed from Article 220 and other applicable articles shall have an ampacity sufficient for the lighting or appliance load plus the required ampacity for the motor-compressor load determined in accordance with Section 440-33, or, for a single motor-compressor, in accordance with Section 440-32.

*Exception: When the circuitry is so interlocked as to prevent simultaneous operation of the motor-compressor(s) and all other loads connected, the conductor size shall be determined from the largest size required for the motor-compressor(s) and other loads to be operated at a given time.*

**440-35. Multimotor and Combination-Load Equipment.** The ampacity of the conductors supplying multimotor and combination-load equipment shall not be less than the minimum circuit ampacity marked on the equipment in accordance with Section 440-4(b).

### E. Controllers for Motor-Compressors

#### 440-41. Rating.

(a) **Motor-Compressor Controller.** A motor-compressor controller shall have both a continuous-duty full-load current rating, and a locked-rotor current rating, not less than the nameplate rated-load current or branch-circuit selection current, whichever is greater, and locked-rotor current, respectively (see Sections 440-6 and 440-7) of the compressor. In case the motor controller is rated in horsepower, but is without one or both of the foregoing current ratings, equivalent currents shall be determined from the ratings as follows: use Tables 430-148, 430-149, or 430-150 to determine the equivalent full-load current rating. Use Table 430-151 to determine the equivalent locked-rotor current ratings.

(b) **Controller Serving More than One Load.** A controller, serving more than one motor-compressor or a motor-compressor and other loads, shall have a continuous-duty full-load current rating, and a locked-rotor current rating not less than the combined load as determined in accordance with Section 440-12(b).

### F. Motor-Compressor and Branch-Circuit Overload Protection

**440-51. General.** The provisions of Part F specify devices intended to protect the motor-compressor, the motor-control apparatus, and the branch-circuit conductors against excessive heating due to motor overload and failure to start. See Section 240-3, Exception No. 3.

(FPN): Note: Overload in electrically driven apparatus is an operating overcurrent which, when it persists for a sufficient length of time, would cause damage or dangerous overheating. It does not include short circuits or ground faults.

#### 440-52. Application and Selection.

(a) **Protection of Motor-Compressor.** Each motor-compressor shall be protected against overload and failure to start by one of the following means:

(1) A separate overload relay which is responsive to motor-compressor current. This device shall be selected to trip at not more than 140 percent of the motor-compressor rated-load current.

(2) A thermal protector integral with the motor-compressor, approved for use with the motor-compressor which it protects on the basis that it will prevent dangerous overheating of the motor-compressor due to overload and failure to start. If the current-interrupting device is separate from the motor-compressor and its control circuit is operated by a protective device integral with the motor-compressor, it shall be so arranged that the opening of the control circuit will result in interruption of current to the motor-compressor.

(3) A fuse or inverse time circuit breaker responsive to motor current, which shall also be permitted to serve as the branch-circuit short-circuit and ground-fault protective device. This device shall be rated at not more than 125 percent of the motor-compressor rated-load current. It shall have sufficient time delay to permit the motor-compressor to start and accelerate its load. The equipment or the motor-compressor shall be marked with this maximum branch-circuit fuse or inverse time circuit breaker rating.

(4) A protective system, furnished or specified and approved for use with the motor-compressor which it protects on the basis that it will prevent dangerous overheating of the motor-compressor due to overload and failure to start. If the current interrupting device is separate from the motor-compressor and its control circuit is operated by a protective device which is not integral with the current-interrupting device, it shall be so arranged that the opening of the control circuit will result in interruption of current to the motor-compressor.

**(b) Protection of Motor-Compressor Control Apparatus and Branch-Circuit Conductors.** The motor-compressor controller(s), the disconnecting means and branch-circuit conductors shall be protected against overcurrent due to motor overload and failure to start by one of the following means which shall be permitted to be the same device or system protecting the motor-compressor in accordance with Section 440-52(a).

*Exception: For motor-compressors and equipment on 15- or 20-ampere single-phase branch circuits as provided in Sections 440-54 and 440-55.*

(1) An overload relay selected in accordance with Section 440-52(a)(1).

(2) A thermal protector applied in accordance with Section 440-52(a)(2) and which will not permit a continuous current in excess of 156 percent of the marked rated-load current or branch-circuit selection current.

(3) A fuse or inverse time circuit breaker selected in accordance with Section 440-52(a)(3).

(4) A protective system in accordance with Section 440-52(a)(4) and which will not permit a continuous current in excess of 156 percent of the marked rated-load current or branch-circuit selection current.

**440-53. Overload Relays.** Overload relays and other devices for motor overload protection, which are not capable of opening short circuits, shall be protected by fuses or inverse time circuit breakers with ratings or settings in accordance with Part C unless approved for group installation or for part-winding motors and marked to indicate the maximum size of fuse or inverse time circuit breaker by which they shall be protected.

*Exception: The fuse or inverse time circuit breaker size marking shall be permitted on the nameplate of approved equipment in which the overload relay or other overload device is used.*

**440-54. Motor-Compressors and Equipment on 15- or 20-Ampere Branch Circuits — Not Cord-and-Attachment Plug-Connected.** Overload protection for motor-compressors and equipment used on 15- or 20-ampere 120-volt, or 15-ampere 208- or 240-volt single-phase branch circuits as permitted in Article 210 shall be permitted as indicated in (a) and (b) below.

**(a) Overload Protection.** The motor-compressor shall be provided with overload protection selected as specified in Section 440-52(a). Both the controller and motor overload protective device shall be approved for installation with the short-circuit and ground-fault protective device for the branch circuit to which the equipment is connected.

**(b) Time Delay.** The short-circuit and ground-fault protective device protecting the branch circuit shall have sufficient time delay to permit the motor-compressor and other motors to start and accelerate their loads.

**440-55. Cord-and-Attachment Plug-Connected Motor-Compressors and Equipment on 15- or 20-Ampere Branch Circuits.** Overload protection for motor-compressors and equipment that are cord-and-attachment plug-connected and used on 15- or 20-ampere 120-volt, or 15-ampere 208- or 240-volt single-phase branch circuits as permitted in Article 210 shall be permitted as indicated in (a), (b), and (c) below.

(a) **Overload Protection.** The motor-compressor shall be provided with overload protection as specified in Section 440-52(a). Both the controller and the motor overload protective device shall be approved for installation with the short-circuit and ground-fault protective device for the branch circuit to which the equipment is connected.

(b) **Attachment Plug and Receptacle Rating.** The rating of the attachment plug and receptacle shall not exceed 20 amperes at 125 volts or 15 amperes at 250 volts.

(c) **Time Delay.** The short-circuit and ground-fault protective device protecting the branch circuit shall have sufficient time delay to permit the motor-compressor and other motors to start and accelerate their loads.

### G. Provisions for Room Air Conditioners

**440-60. General.** The provisions of Part G shall apply to electrically energized room air conditioners that control temperature and humidity. For the purpose of Part G, a room air conditioner (with or without provisions for heating) shall be considered as an alternating-current appliance of the air-cooled window, console, or in-wall type that is installed in the conditioned room and which incorporates a hermetic refrigerant motor-compressor(s). The provisions of Part G cover equipment rated not over 250 volts, single phase, and such equipment shall be permitted to be cord-and-attachment plug-connected.

A room air conditioner that is rated three phase or rated over 250 volts shall be directly connected to a wiring method recognized in Chapter 3, and provisions of Part G shall not apply.

**440-61. Grounding.** Room air conditioners shall be grounded in accordance with Sections 250-42, 250-43, and 250-45.

#### 440-62. Branch-Circuit Requirements.

(a) **Room Air Conditioner as a Single Motor Unit.** A room air conditioner shall be considered as a single motor unit in determining its branch-circuit requirements when all the following conditions are met:

- (1) It is cord-and-attachment plug-connected.
- (2) Its rating is not more than 40 amperes and 250 volts, single phase.
- (3) Total rated-load current is shown on the room air-conditioner nameplate rather than individual motor currents, and
- (4) The rating of the branch-circuit short-circuit and ground-fault protective device does not exceed the ampacity of the branch-circuit conductors or the rating of the receptacle, whichever is less.

(b) **Where No Other Loads Are Supplied.** The total marked rating of a cord-and-attachment plug-connected room air conditioner shall not exceed 80 percent of the rating of a branch circuit where no other loads are supplied.

(c) **Where Lighting Units or Other Appliances Are also Supplied.** The total marked rating of a cord-and-attachment plug-connected room air conditioner shall not exceed 50 percent of the rating of a branch circuit where lighting units or other appliances are also supplied.

**440-63. Disconnecting Means.** An attachment plug and receptacle shall be permitted to serve as the disconnecting means for a single-phase room air conditioner rated 250 volts or less if: (1) the manual controls on the room air conditioner are readily accessible and located within 6 feet (1.83 m) of the floor, or (2) an approved manually operable switch is installed in a readily accessible location within sight from the room air conditioner.

**440-64. Supply Cords.** Where a flexible cord is used to supply a room air conditioner, the length of such cord shall not exceed: (1) 10 feet (3.05 m) for a nominal, 120-volt rating, or (2) 6 feet (1.83 m) for a nominal 208- or 240-volt rating.

## ARTICLE 445 — GENERATORS

**445-1. General.** Generators and their associated wiring and equipment shall also comply with the applicable provisions of Articles 230, 250, 700, 701, and 702.

**445-2. Location.** Generators shall be of a type suitable for the locations in which they are installed. They shall also meet the requirements for motors in Section 430-14. Generators installed in hazardous (classified) locations as described in Articles 500 through 503, or in other locations as described in Articles 510 through 517, and in Articles 520, 530, and 665 shall also comply with the applicable provisions of those articles.

**445-3. Marking.** Each generator shall be provided with a nameplate giving the maker's name, the rated frequency, power factor, number of phases if of alternating current, the rating in kilowatts or kilovolt amperes, the normal volts and amperes corresponding to the rating, rated revolutions per minute, insulation system class and rated ambient temperature or rated temperature rise, and time rating.

**445-4. Overcurrent Protection.**

(a) **Constant-Voltage Generators.** Constant-voltage generators, except alternating-current generator exciters, shall be protected from overloads by inherent design, circuit breakers, fuses, or other acceptable overcurrent protective means, suitable for the conditions of use.

(b) **Two-Wire Generators.** Two-wire, direct-current generators shall be permitted to have overcurrent protection in one conductor only if the overcurrent device is actuated by the entire current generated other than the current in the shunt field. The overcurrent device shall not open the shunt field.

(c) **65 Volts or Less.** Generators operating at 65 volts or less and driven by individual motors shall be considered as protected by the overcurrent device protecting the motor if these devices will operate when the generators are delivering not more than 150 percent of their full-load rated current.

**(d) Balancer Sets.** Two-wire, direct-current generators used in conjunction with balancer sets to obtain neutrals for 3-wire systems shall be equipped with overcurrent devices that will disconnect the 3-wire system in case of excessive unbalancing of voltages or currents.

**(e) 3-Wire, Direct-Current Generators.** Three-wire, direct-current generators, whether compound or shunt wound, shall be equipped with overcurrent devices, one in each armature lead, and so connected as to be actuated by the entire current from the armature. Such overcurrent devices shall consist either of a double-pole, double-coil circuit breaker, or of a 4-pole circuit breaker connected in the main and equalizer leads and tripped by two overcurrent devices, one in each armature lead. Such protective devices shall be so interlocked that no one pole can be opened without simultaneously disconnecting both leads of the armature from the system.

*Exception to (a) through (e): Where deemed by the authority having jurisdiction, a generator is vital to the operation of an electrical system and the generator should operate to failure to prevent a greater hazard to persons, the overload sensing device(s) shall be permitted to be connected to an annunciator or alarm supervised by authorized personnel instead of interrupting the generator circuit.*

**445-5. Ampacity of Conductors.** The ampacity of the phase conductors from the generator terminals to the first overcurrent device shall not be less than 115 percent of the nameplate current rating of the generator. It shall be permitted to size the neutral conductors in accordance with Section 220-22. Conductors which must carry ground-fault currents shall not be smaller than required by Section 250-23(b).

*Exception No. 1: Where the design and operation of the generator prevent overloading, the ampacity of the conductors shall not be less than 100 percent of the nameplate current rating of the generator.*

*Exception No. 2: Where the generator manufacturer's leads are connected directly to an overcurrent device that is an integral part of the generator set assembly.*

**445-6. Protection of Live Parts.** Live parts of generators operated at more than 50 volts to ground shall not be exposed to accidental contact where accessible to unqualified persons.

**445-7. Guards for Attendants.** Where necessary for the safety of attendants, the requirements of Section 430-133 shall apply.

**445-8. Bushings.** Where wires pass through an opening in an enclosure, conduit box, or barrier, a bushing shall be used to protect the conductors from the edges of an opening having sharp edges. The bushing shall have smooth, well-rounded surfaces where it may be in contact with the conductors. If used where oils, grease, or other contaminants may be present, the bushing shall be made of a material not deleteriously affected.



## ARTICLE 450 — TRANSFORMERS AND TRANSFORMER VAULTS

### (Including Secondary Ties)

**450-1. Scope.** This article covers the installation of all transformers.

*Exception No. 1: Current transformers.*

*Exception No. 2: Dry-type transformers that constitute a component part of other apparatus and comply with the requirements for such apparatus.*

*Exception No. 3: Transformers which are an integral part of an X-ray, high-frequency, or electrostatic-coating apparatus.*

*Exception No. 4: Transformers used with Class 2 and Class 3 circuits that comply with Article 725.*

*Exception No. 5: Transformers for sign and outline lighting that comply with Article 600.*

*Exception No. 6: Transformers for electric-discharge lighting that comply with Article 410.*

*Exception No. 7: Transformers used for power-limited fire protective signaling circuits that comply with Part C of Article 760.*

*Exception No. 8: Liquid-filled or dry-type transformers used for research, development, or testing, where effective arrangements are provided to safeguard unqualified persons from contacting high-voltage terminals or energized conductors.*

This article also covers the installation of transformers in hazardous (classified) locations as modified by Articles 501 through 503.

### A. General Provisions

**450-2. Definitions.** For the purpose of this article:

**Transformer:** The word transformer is intended to mean an individual transformer, single- or polyphase, identified by a single nameplate, unless otherwise indicated in this article.

**450-3. Overcurrent Protection.** Overcurrent protection shall comply with (a), (b), or (c) below. As used in this section, the word "transformer" shall mean a transformer or polyphase bank of two or three single-phase transformers operating as a unit.

#### (a) Transformers Over 600 Volts, Nominal.

(1) **Primary and Secondary.** Each transformer over 600 volts, nominal, shall have primary and secondary protective devices rated or set to open at no more than the values noted in Table 450-3(a)(1).

*Exception No. 1: Where the required fuse rating or circuit breaker setting does not correspond to a standard rating or setting, the next higher standard rating or setting shall be permitted.*

*Exception No. 2: As provided in (a)(2) below.*

(2) **Supervised Installations.** Where conditions of maintenance and supervision assure that only qualified persons will monitor and service the

**Table 450-3(a)(1)**  
**Transformers Over 600 Volts**

Maximum Rating or Setting for Overcurrent Device					
Primary			Secondary		
Transformer Rated Impedance	Over 600 Volts		Over 600 Volts	600 Volts or Below	
	Circuit Breaker Setting	Fuse Rating	Circuit Breaker Setting	Fuse Rating	Circuit Breaker Setting or Fuse Rating
Not more than 6%	600%	300%	300%	250%	125%
More than 6% and not more than 10%	400%	300%	250%	225%	125%

transformer installation, overcurrent protection as provided in (a)(2) shall be permitted.

a. Primary. Each transformer over 600 volts, nominal, shall be protected by an individual overcurrent device on the primary side. Where fuses are used, their continuous current rating shall not exceed 250 percent of the rated primary current of the transformer. Where circuit breakers are used, they shall be set at not more than 300 percent of the rated primary current of the transformer.

*Exception No. 1: Where the required fuse rating or circuit breaker setting does not correspond to a standard rating or setting, the next higher standard rating or setting shall be permitted.*

*Exception No. 2: An individual overcurrent device shall not be required where the primary circuit overcurrent device provides the protection specified in this section.*

*Exception No. 3: As provided in (a)(2)b. below:*

b. Primary and Secondary. A transformer over 600 volts, nominal, having an overcurrent device on the secondary side rated or set to open at not more than the values noted in Table 450-3(a)(2)b., or a transformer equipped with a coordinated thermal overload protection by the manufacturer, shall not be required to have an individual overcurrent device in the primary connection provided the primary feeder overcurrent device is rated or set to open at not more than the values noted in Table 450-3(a)(2)b.

**(b) Transformers 600 Volts, Nominal, or Less.**

**(1) Primary.** Each transformer 600 volts, nominal, or less, shall be protected by an individual overcurrent device on the primary side, rated or set at not more than 125 percent of the rated primary current of the transformer.

*Exception No. 1: Where the rated primary current of a transformer is 9 amperes or more and 125 percent of this current does not correspond to a standard rating of a fuse or nonadjustable circuit breaker, the next higher standard rating described in Section 240-6 shall be permitted. Where the rated primary current is less than 9 amperes, an overcurrent device rated or set at not more than 167 percent of the primary current shall be permitted.*

**Table 450-3(a)(2)b.**  
**Transformers Over 600 Volts in Supervised Locations**

Maximum Rating or Setting for Overcurrent Device					
Primary			Secondary		
Over 600 Volts			Over 600 Volts		600 Volts or Below
Transformer Rated Impedance	Circuit Breaker Setting	Fuse Rating	Circuit Breaker Setting	Fuse Rating	Circuit Breaker Setting or Fuse Rating
Not more than 6%	600%	300%	300%	250%	250%
More than 6% and not more than 10%	400%	300%	250%	225%	250%

Where the rated primary current is less than 2 amperes, an overcurrent device rated or set at not more than 300 percent shall be permitted.

*Exception No. 2:* An individual overcurrent device shall not be required where the primary circuit overcurrent device provides the protection specified in this section.

*Exception No. 3:* As provided in (b)(2) below.

**(2) Primary and Secondary.** A transformer 600 volts, nominal, or less, having an overcurrent device on the secondary side rated or set at not more than 125 percent of the rated secondary current of the transformer shall not be required to have an individual overcurrent device on the primary side if the primary feeder overcurrent device is rated or set at a current value not more than 250 percent of the rated primary current of the transformer.

A transformer 600 volts, nominal, or less, equipped with coordinated thermal overload protection by the manufacturer and arranged to interrupt the primary current, shall not be required to have an individual overcurrent device on the primary side if the primary feeder overcurrent device is rated or set at a current value not more than six times the rated current of the transformer for transformers having not more than 6 percent impedance, and not more than four times the rated current of the transformer for transformers having more than 6 but not more than 10 percent impedance.

*Exception:* Where the rated secondary current of a transformer is 9 amperes or more and 125 percent of this current does not correspond to a standard rating of a fuse or nonadjustable circuit breaker, the next higher standard rating described in Section 240-6 shall be permitted.

Where the rated secondary current is less than 9 amperes, an overcurrent device rated or set at not more than 167 percent of the rated secondary current shall be permitted.

**(c) Potential (Voltage) Transformers.** Potential transformers installed indoors or enclosed shall be protected with primary fuses.

(FPN): See also Section 384-22.

#### **450-4. Autotransformers 600 Volts, Nominal, or Less.**

**(a) Overcurrent Protection.** Each autotransformer 600 volts, nominal, or less shall be protected by an individual overcurrent device installed in series

with each ungrounded input conductor. Such overcurrent device shall be rated or set at not more than 125 percent of the rated full-load input current of the autotransformer. An overcurrent device shall not be installed in series with the shunt winding (the winding common to both the input and the output circuits) of the autotransformer between Points A and B as shown in Diagram 450-4.

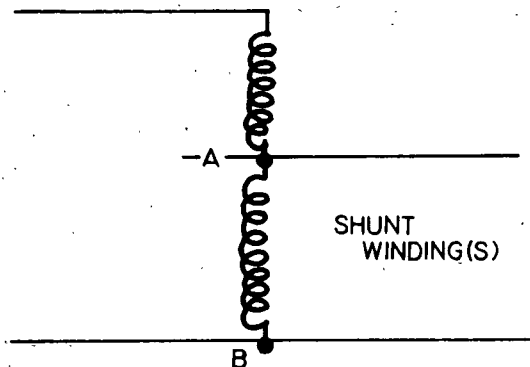

Diagram 450-4

*Exception:* Where the rated input current of an autotransformer is 9 amperes or more and 125 percent of this current does not correspond to a standard rating of a fuse or nonadjustable circuit breaker, the next higher standard rating described in Section 240-6 shall be permitted. Where the rated input current is less than 9 amperes, an overcurrent device rated or set at not more than 167 percent of the input current shall be permitted.

**(b) Transformer Field-Connected as an Autotransformer.** A transformer field-connected as an autotransformer shall be identified for use at elevated voltage.

(FPN): For information on permitted uses of autotransformers, see Section 210-9.

**450-5. Grounding Autotransformers.** Grounding autotransformers covered in this section are zig-zag or T-connected transformers connected to 3-phase, 3-wire ungrounded systems for the purpose of creating a 3-phase, 4-wire distribution system or to provide a neutral reference for grounding purposes. Such transformers shall have a continuous per phase current rating and a continuous neutral current rating.

(FPN): The phase current in a grounding autotransformer is one-third the neutral current.

**(a) Three-Phase, 4-Wire System.** A grounding autotransformer used to create a 3-phase, 4-wire distribution system from a 3-phase, 3-wire ungrounded system shall conform to the following:

**(1) Connections.** The transformer shall be directly connected to the ungrounded phase conductors and shall not be switched or provided with overcurrent protection which is independent of the main switch and common-trip overcurrent protection for the 3-phase, 4-wire system.

**(2) Overcurrent Protection.** An overcurrent sensing device shall be provided that will cause the main switch or common-trip overcurrent protection referred to in (a)(1) above to open if the load on the autotransformer reaches or exceeds 125 percent of its continuous current per phase or neutral rating. Delayed tripping for temporary overcurrents sensed at the autotransformer overcurrent device shall be permitted for the purpose of allowing proper operation of branch or feeder protective devices on the 4-wire system.

**(3) Transformer Fault Sensing.** A fault sensing system that will cause the opening of a main switch or common-trip overcurrent device for the 3-phase, 4-wire system shall be provided to guard against single-phasing or internal faults.

(FPN): This can be accomplished by the use of two subtractive-connected donut-type current transformers installed to sense and signal when an unbalance occurs in the line current to the autotransformer of 50 percent or more of rated current.

**(4) Rating.** The autotransformer shall have a continuous neutral current rating sufficient to handle the maximum possible neutral unbalanced load current of the 4-wire system.

**(b) Ground Reference for Fault Protection Devices.** A grounding autotransformer used to make available a specified magnitude of ground-fault current for operation of a ground responsive protective device on a 3-phase, 3-wire ungrounded system shall conform to the following requirements:

**(1) Rating.** The autotransformer shall have a continuous neutral current rating sufficient for the specified ground-fault current.

**(2) Overcurrent Protection.** An overcurrent protective device of adequate short-circuit rating that will open simultaneously all ungrounded conductors when it operates shall be applied in the grounding autotransformer branch circuit and rated or set at a current not exceeding 125 percent of the autotransformer continuous per phase current rating or 42 percent of the continuous current rating of any series connected devices in the autotransformer neutral connection. Delayed tripping for temporary overcurrents to permit the proper operation of ground responsive tripping devices on the main system shall be permitted, but shall not exceed values which would be more than the short-time current rating of the grounding autotransformer or any series connected devices in the neutral connection thereto.

**(c) Ground Reference for Damping Transitory Overvoltages.** A grounding autotransformer used to limit transitory overvoltages shall be of suitable rating and connected in accordance with (a)(1) above.

**450-6. Secondary Ties.** A secondary tie is a circuit operating at 600 volts, nominal, or less, between phases that connects two power sources or power supply points, such as the secondaries of two transformers. The tie shall be permitted to consist of one or more conductors per phase.

As used in this section, the word "transformer" means a transformer or a bank of transformers operating as a unit.

**(a) Tie Circuits.** Tie circuits shall be provided with overcurrent protection at each end as required in Article 240.

*Exception: Under the conditions described in (a)(1) and (a)(2) below, the overcurrent protection shall be permitted to be in accordance with (a)(3) below.*

**(1) Loads at Transformer Supply Points Only.** Where all loads are connected at the transformer supply points at each end of the tie and overcurrent protection is not provided in accordance with Article 240, the rated ampacity of the tie shall not be less than 67 percent of the rated secondary current of the largest transformer connected to the secondary tie system.

**(2) Loads Connected Between Transformer Supply Points.** Where load is connected to the tie at any point between transformer supply points and overcurrent protection is not provided in accordance with Article 240, the rated ampacity of the tie shall not be less than 100 percent of the rated secondary current of the largest transformer connected to the secondary tie system.

*Exception: As otherwise provided in (a)(4) below.*

**(3) Tie Circuit Protection.** Under the conditions described in (a)(1) and (a)(2) above, both ends of each tie conductor shall be equipped with a protective device that will open at a predetermined temperature of the tie conductor under short-circuit conditions. This protection shall consist of one of the following: (1) a fusible link cable connector, terminal, or lug, commonly known as a limiter, each being of a size corresponding with that of the conductor and of construction and characteristics according to the operating voltage and the type of insulation on the tie conductors, or (2) automatic circuit breakers actuated by devices having comparable current-time characteristics.

**(4) Interconnection of Phase Conductors Between Transformer Supply Points.** Where the tie consists of more than one conductor per phase, the conductors of each phase shall be interconnected in order to establish a load supply point, and the protection specified in (a)(3) above shall be provided in each tie conductor at this point.

*Exception: Loads shall be permitted to be connected to the individual conductors of a paralleled conductor tie without interconnecting the conductors of each phase and without the protection specified in (a)(3) above at load connection points provided the tie conductors of each phase have a combined capacity of not less than 133 percent of the rated secondary current of the largest transformer connected to the secondary tie system; the total load of such taps does not exceed the rated secondary current of the largest transformer; and the loads are equally divided on each phase and on the individual conductors of each phase as far as practicable.*

**(5) Tie Circuit Control.** Where the operating voltage exceeds 150 volts to ground, secondary ties provided with limiters shall have a switch at each end that, when open, will de-energize the associated tie conductors and limiters. The current rating of the switch shall not be less than the rated current of the conductors connected to the switch. It shall be capable of opening its rated current, and it shall be constructed so that it will not open under the magnetic forces resulting from short-circuit current.

**(b) Overcurrent Protection for Secondary Connections.** Where secondary ties are used, an overcurrent device rated or set at not more than 250 percent of the rated secondary current of the transformers shall be provided in the secondary connections of each transformer. In addition, an automatic circuit breaker actuated by a reverse-current relay set to open the circuit at not more than the rated secondary current of the transformer shall be provided in the secondary connection of each transformer.

**450-7. Parallel Operation.** Transformers shall be permitted to be operated in parallel and switched as a unit provided that the overcurrent protection for each transformer meets the requirements of Section 450-3 (a)(1) or (b)(2).

**450-8. Guarding.** Transformers shall be guarded as specified in (a) through (d) below.

**(a) Mechanical Protection.** Appropriate provisions shall be made to minimize the possibility of damage to transformers from external causes where the transformers are exposed to physical damage.

**(b) Case or Enclosure.** Dry-type transformers shall be provided with a noncombustible moisture-resistant case or enclosure that will provide reasonable protection against the accidental insertion of foreign objects.

**(c) Exposed Live Parts.** Transformers shall be so installed that live parts are guarded in accordance with Sections 110-17 and 110-34.

**(d) Voltage Warning.** The operating voltage of exposed live parts of transformer installations shall be indicated by signs or visible markings on the equipment or structures.

**450-9. Ventilation.** The ventilation shall be adequate to dispose of the transformer full-load losses without creating temperature rise which is in excess of the transformer rating.

(FPN): See ANSI/IEEE C57.12.00-1980, General Requirements for Liquid-Immersed Distribution, Power, and Regulating Transformers and ANSI/IEEE C57.12.01-1979, General Requirements for Dry-Type Distribution and Power Transformers.

**450-10. Grounding.** Exposed noncurrent-carrying metal parts of transformer installations, including fences, guards, etc., shall be grounded where required under the conditions and in the manner specified for electric equipment and other exposed metal parts in Article 250.

**450-11. Marking.** Each transformer shall be provided with a nameplate giving the name of the manufacturer; rated kilovolt-amperes; frequency; primary and secondary voltage; impedance of transformers 25 kVA and larger; and the amount and kind of insulating liquid where used. In addition, the nameplate of each dry-type transformer shall include the temperature class for the insulation system.

**450-12. Terminal Wiring Space.** The minimum wire bending space at fixed, 600 volts and below terminals of transformer line and load connections shall be as required in Section 373-6. Wiring space for pigtail connections shall conform to Table 370-6(b).

**450-13. Location.** Transformers and transformer vaults shall be readily accessible to qualified personnel for inspection and maintenance.

*Exception No. 1: Dry-type transformers, 600 volts, nominal, or less, located in the open on walls, columns, or structures, shall not be required to be readily accessible.*

*Exception No. 2: Dry-type transformers not exceeding 600 volts, nominal, and 50 kVA shall be permitted in fire-resistant hollow spaces of buildings not permanently closed in by structure and provided they meet the ventilation requirements of Section 450-9.*

Unless specified otherwise in this article, the term "fire resistant" means a construction having a minimum fire rating of 1 hour.

(FPN): See ANSI/ASTM E119-83, and Fire Tests of Building Construction and Materials, NFPA 251-1985.

(FPN): The location of different types of transformers is covered in Part B of Article 450. The location of transformer vaults is covered in Section 450-41.

## B. Specific Provisions Applicable to Different Types of Transformers

### 450-21. Dry-type Transformers Installed Indoors.

(a) **Not Over 112½ kVA.** Dry-type transformers installed indoors and rated 112½ kVA or less shall have a separation of at least 12 inches (305 mm) from combustible material unless separated therefrom by a fire-resistant, heat-insulating barrier, or unless of a rating not over 600 volts and completely enclosed except for ventilating openings.

(b) **Over 112½ kVA.** Individual dry-type transformers of more than 112½ kVA rating shall be installed in a transformer room of fire-resistant construction.

*Exception No. 1 to (b): Transformers with 80°C rise or higher ratings and separated from combustible material by a fire-resistant, heat-insulating barrier or by not less than 6 feet (1.83 m) horizontally and 12 feet (3.66 m) vertically.*

*Exception No. 2 to (b): Transformers with 80°C rise or higher ratings and of completely enclosed and ventilated-type construction.*

(c) **Over 35,000 Volts.** Dry-type transformers rated over 35,000 volts shall be installed in a vault complying with Part C of this article.

**450-22. Dry-type Transformers Installed Outdoors.** Dry-type transformers installed outdoors shall have a weatherproof enclosure.

Transformers exceeding 112½ kVA shall not be located within 12 inches (305 mm) of combustible materials of buildings.

**450-23. Less-Flammable Liquid-Insulated Transformers.** Transformers insulated with listed less-flammable liquids shall be permitted to be installed without a vault in Type I and Type II buildings in areas in which no combustible materials are stored, provided there is a liquid confinement area, the liquid has a fire point of not less than 300°C, and the installation complies with all restrictions provided for in the listing of the liquid. Such indoor transformer installations not meeting the restrictions of the liquid listing, or installed in other than Type I or Type II buildings, or in areas where combustible materials are stored, shall (1) be provided with an automatic fire extinguishing system and a liquid confinement area, or (2) be installed in a vault complying with Part C of this article.



Transformers installed indoors and rated over 35,000 volts shall be installed in a vault.

Transformers installed outdoors shall comply with the safeguards of Section 450-27.

(FPN): As used in this section, "noncombustible" refers to Type I and Type II building construction and noncombustible materials as defined in Types of Building Construction, NFPA 220-1985 (ANSI).

(FPN): See definition of "listed" in Article 100.

**450-24. Nonflammable Fluid-Insulated Transformers.** Transformers insulated with a dielectric fluid identified as nonflammable shall be permitted to be installed indoors or outdoors. Such transformers installed indoors and rated over 35,000 volts shall be installed in a vault.

For the purposes of this section, a nonflammable dielectric fluid is one which does not have a flash point or fire point, and is not flammable in air.

**450-25. Askarel-Insulated Transformers Installed Indoors.** Askarel-insulated transformers installed indoors and rated over 25 kVA shall be furnished with a pressure-relief vent. Where installed in a poorly ventilated place, they shall be furnished with a means for absorbing any gases generated by arcing inside the case, or the pressure-relief vent shall be connected to a chimney or flue that will carry such gases outside the building. Askarel-insulated transformers rated over 35,000 volts shall be installed in a vault.

**450-26. Oil-Insulated Transformers Installed Indoors.** Oil-insulated transformers installed indoors shall be installed in a vault constructed as specified in Part C of this article.

*Exception No. 1: Where the total capacity does not exceed 112½ kVA, the vault specified in Part C of this article shall be permitted to be constructed of reinforced concrete not less than 4 inches (102 mm) thick.*

*Exception No. 2: Where the nominal voltage does not exceed 600, a vault shall not be required if suitable arrangements are made to prevent a transformer oil fire from igniting other materials, and the total capacity in one location does not exceed 10 kVA in a section of the building classified as combustible, or 75 kVA where the surrounding structure is classified as fire-resistant construction.*

*Exception No. 3: Electric furnace transformers having a total rating not exceeding 75 kVA shall be permitted to be installed without a vault in a building or room of fire-resistant construction, provided suitable arrangements are made to prevent a transformer oil fire from spreading to other combustible material.*

*Exception No. 4: Transformers shall be permitted to be installed in a detached building that does not comply with Part C of this article if neither the building nor its contents presents a fire hazard to any other building or property, and if the building is used only in supplying electric service and the interior is accessible only to qualified persons.*

*Exception No. 5: Oil-insulated transformers shall be permitted to be used without a vault in portable and mobile surface mining equipment (such as electric excavators) if each of the following conditions is met:*

- a. Provision is made for draining leaking fluid to the ground.
- b. Safe egress is provided for personnel.

c. A minimum 1/4-inch (6.35-mm) steel barrier is provided for personnel protection.

**450-27. Oil-Insulated Transformers Installed Outdoors.** Combustible material, combustible buildings, and parts of buildings, fire escapes, and door and window openings shall be safeguarded from fires originating in oil-insulated transformers installed on roofs, attached to, or adjacent to a building or combustible material.

Space separations, fire-resistant barriers, automatic water spray systems, and enclosures that confine the oil of a ruptured transformer tank are recognized safeguards. One or more of these safeguards shall be applied according to the degree of hazard involved in cases where the transformer installation presents a fire hazard.

Oil enclosures shall be permitted to consist of fire-resistant dikes, curbed areas or basins, or trenches filled with coarse-crushed stone. Oil enclosures shall be provided with trapped drains where the exposure and the quantity of oil involved are such that removal of oil is important.

(FPN): For additional information on transformers installed on poles or structures or underground, see National Electrical Safety Code, ANSI C2-1984.

**450-28. Modification of Transformers.** When modifications are made to a transformer in an existing installation which changes the type of the transformer with respect to Part B of this article, such transformer shall be marked to show the type of insulating liquid installed and the modified transformer installation shall comply with the applicable requirements for that type of transformer.

### C. Transformer Vaults

**450-41. Location.** Vaults shall be located where they can be ventilated to the outside air without using flues or ducts wherever such an arrangement is practicable.

**450-42. Walls, Roof and Floor.** The walls and roofs of vaults shall be constructed of materials which have adequate structural strength for the conditions with a minimum fire resistance of 3 hours. The floors of vaults in contact with the earth shall be of concrete not less than 4 inches (102 mm) thick, but when the vault is constructed with a vacant space or other stories below it, the floor shall have adequate structural strength for the load imposed thereon and a minimum fire resistance of 3 hours.

(FPN): For additional information, see ANSI/ASTM E119-83, and Fire Tests of Building Construction and Materials, NFPA 251-1985.

(FPN): Six-inch (152-mm) thick reinforced concrete is a typical 3-hour construction.

*Exception: Where transformers are protected with automatic sprinkler, water spray, carbon dioxide, or halon, construction of 1-hour rating shall be permitted.*

**450-43. Doorways.** Vault doorways shall be protected as follows:

(a) **Type of Door.** Each doorway leading into a vault from the building interior shall be provided with a tight-fitting door having a minimum fire rating of 3 hours. The authority having jurisdiction shall be permitted to require such a door for an exterior wall opening where conditions warrant.

*Exception: Where transformers are protected with automatic sprinkler, water spray, carbon dioxide, or halon, construction of 1-hour rating shall be permitted.*

(FPN): For additional information, see Standard for Fire Doors and Windows, NFPA 80-1983 (ANSI).

**(b) Sills.** A door sill or curb of sufficient height to confine within the vault the oil from the largest transformer shall be provided, and in no case shall the height be less than 4 inches (102 mm).

**(c) Locks.** Entrance doors shall be equipped with locks, and doors shall be kept locked, access being allowed only to qualified persons. Locks and latches shall be so arranged that the door can be readily and quickly opened from the inside.

**450-45. Ventilation Openings.** Where required by Section 450-9, openings for ventilation shall be provided in accordance with (a) through (f) below.

**(a) Location.** Ventilation openings shall be located as far away as possible from doors, windows, fire escapes, and combustible material.

**(b) Arrangement.** A vault ventilated by natural circulation of air shall be permitted to have roughly half of the total area of openings required for ventilation in one or more openings near the floor and the remainder in one or more openings in the roof or in the sidewalls near the roof, or all of the area required for ventilation shall be permitted in one or more openings in or near the roof.

**(c) Size.** For a vault ventilated by natural circulation of air to an outdoor area, the combined net area of all ventilating openings, after deducting the area occupied by screens, gratings, or louvers, shall not be less than 3 square inches (1936 sq mm) per kVA of transformer capacity in service, and in no case shall the net area be less than 1 square foot (0.093 sq m) for any capacity under 50 kVA.

**(d) Covering.** Ventilation openings shall be covered with durable gratings, screens, or louvers, according to the treatment required in order to avoid unsafe conditions.

**(e) Dampers.** All ventilation openings to the indoors shall be provided with automatic closing fire dampers that operate in response to a vault fire. Such dampers shall possess a standard fire rating of not less than 1½ hours.

(FPN): See Standard for Fire Dampers, ANSI/UL 555-1972.

**(f) Ducts.** Ventilating ducts shall be constructed of fire-resistant material.

**450-46. Drainage.** Where practicable, vaults containing more than 100 kVA transformer capacity shall be provided with a drain or other means that will carry off any accumulation of oil or water in the vault unless local conditions make this impracticable. The floor shall be pitched to the drain where provided.

**450-47. Water Pipes and Accessories.** Any pipe or duct system foreign to the electrical installation shall not enter or pass through a transformer vault. Piping or other facilities provided for vault fire protection, or for transformer cooling, shall not be considered foreign to the electrical installation.

**450-48. Storage in Vaults.** Materials shall not be stored in transformer vaults.

## ARTICLE 460 — CAPACITORS

**460-1. Scope.** This article covers the installation of capacitors on electric circuits.

Surge capacitors or capacitors included as a component part of other apparatus and conforming with the requirements of such apparatus are excluded from these requirements.

This article also covers the installation of capacitors in hazardous (classified) locations as modified by Articles 501 through 503.

**460-2. Enclosing and Guarding.**

(a) **Containing More than 3 Gallons (11.36 L) of Flammable Liquid.** Capacitors containing more than 3 gallons (11.36 L) of flammable liquid shall be enclosed in vaults or outdoor fenced enclosures complying with Article 710.

(b) **Accidental Contact.** Capacitors shall be enclosed, located, or guarded so that persons cannot come into accidental contact or bring conducting materials into accidental contact with exposed energized parts, terminals, or buses associated with them.

*Exception: No additional guarding is required for enclosures accessible only to authorized and qualified persons.*

### A. 600 Volts, Nominal, and Under

**460-6. Drainage of Stored Charge.** Capacitors shall be provided with a means of draining the stored charge.

(a) **Time of Discharge.** The residual voltage of a capacitor shall be reduced to 50 volts, nominal, or less, within 1 minute after the capacitor is disconnected from the source of supply.

(b) **Means of Discharge.** The discharge circuit shall be either permanently connected to the terminals of the capacitor or capacitor bank, or provided with automatic means of connecting it to the terminals of the capacitor bank on removal of voltage from the line. Manual means of switching or connecting the discharge circuit shall not be used.

**460-8. Conductors.**

(a) **Ampacity.** The ampacity of capacitor circuit conductors shall not be less than 135 percent of the rated current of the capacitor. The ampacity of conductors that connect a capacitor to the terminals of a motor or to motor circuit conductors shall not be less than one third the ampacity of the motor circuit conductors and in no case less than 135 percent of the rated current of the capacitor.

(b) **Overcurrent Protection.**

(1) An overcurrent device shall be provided in each ungrounded conductor for each capacitor bank.

*Exception: A separate overcurrent device shall not be required for a capacitor connected on the load side of a motor overload protective device.*

(2) The rating or setting of the overcurrent device shall be as low as practicable.

**(c) Disconnecting Means.**

(1) A disconnecting means shall be provided in each ungrounded conductor for each capacitor bank.

*Exception: Where a capacitor is connected on the load side of a motor overload protective device.*

(2) The disconnecting means shall open all ungrounded conductors simultaneously.

(3) The disconnecting means shall be permitted to disconnect the capacitor from the line as a regular operating procedure.

(4) The rating of the disconnecting means shall not be less than 135 percent of the rated current of the capacitor.

**460-9. Rating or Setting of Motor Overload Device.** Where a motor installation includes a capacitor connected on the load side of the motor overload device, the rating or setting of the motor overload device shall be determined in accordance with Section 430-32.

*Exception: Instead of using the full-load rated current of the motor as provided in Section 430-32, a lower value corresponding with the improved power factor of the motor circuit shall be used. Section 430-22 applies with respect to the rating of the motor circuit conductors.*

**460-10. Grounding.** Capacitor cases shall be grounded in accordance with Article 250.

*Exception: Where the capacitor units are supported on a structure which is designed to operate at other than ground potential.*

**460-12. Marking.** Each capacitor shall be provided with a nameplate giving the name of the manufacturer, rated voltage, frequency, kilovar or amperes, number of phases, and, if filled with a combustible liquid, the amount of liquid in gallons. When filled with a nonflammable liquid, the nameplate shall so state. The nameplate shall also indicate if a capacitor has a discharge device inside the case.

## **B. Over 600 Volts, Nominal**

### **460-24. Switching.**

(a) **Load Current.** Group-operated switches shall be used for capacitor switching and shall be capable of (1) carrying continuously not less than 135 percent of the rated current of the capacitor installation; (2) interrupting the maximum continuous load current of each capacitor, capacitor bank, or capacitor installation that will be switched as a unit; (3) withstanding the maximum inrush current, including contributions from adjacent capacitor installations; (4) carrying currents due to faults on capacitor side of switch.

**(b) Isolation.**

(1) A means shall be installed to isolate from all sources of voltage each capacitor, capacitor bank, or capacitor installation that will be removed from service as a unit.

(2) The isolating means shall provide a visible gap in the electrical circuit adequate for the operating voltage.

(3) Isolating or disconnecting switches (with no interrupting rating) shall be interlocked with the load interrupting device or shall be provided with prominently displayed caution signs in accordance with Section 710-22 to prevent switching load current.

(c) **Additional Requirements for Series Capacitors.** The proper switching sequence shall be assured by use of one of the following: (1) mechanically sequenced isolating and bypass switches; (2) interlocks; or (3) switching procedure prominently displayed at the switching location.

**460-25. Overcurrent Protection.**

(a) **Provided to Detect and Interrupt Fault-Current.** A means shall be provided to detect and interrupt fault current likely to cause dangerous pressure within an individual capacitor.

(b) **Single-Phase or Multiphase Devices.** Single-phase or multiphase devices shall be permitted for this purpose.

(c) **Protected Individually or in Groups.** Capacitors shall be permitted to be protected individually or in groups.

(d) **Protective Devices Rated or Adjusted.** Protective devices for capacitors or capacitor equipment shall be rated or adjusted to operate within the limits of the Safe Zone for individual capacitors.

*Exception: If the protective devices are rated or adjusted to operate within the limits for Zone 1 or Zone 2, the capacitors shall be enclosed or isolated.*

In no event shall the rating or adjustment of the protective devices exceed the maximum limit of Zone 2.

(FPN): For definitions of the Safe Zone, Zone 1, and Zone 2, see the Standard for Shunt Power Capacitors, ANSI/IEEE 18-1980.

**460-26. Identification.** Each capacitor shall be provided with a permanent nameplate giving the maker's name, rated voltage, frequency, kilovar or amperes, number of phases, and the amount of liquid in gallons identified as flammable, if such is the case.

**460-27. Grounding.** Capacitor neutrals and cases, if grounded, shall be grounded in accordance with Article 250:

*Exception: Where the capacitor units are supported on a structure which is designed to operate at other than ground potential.*

**460-28. Means for Discharge.**

(a) **Means to Reduce the Residual Voltage.** A means shall be provided to reduce the residual voltage of a capacitor to 50 volts or less within 5 minutes after the capacitor is disconnected from the source of supply.

(b) **Connection to Terminals.** A discharge circuit shall be either permanently connected to the terminals of the capacitor or provided with automatic means of connecting it to the terminals of the capacitor bank after discon-

nection of the capacitor from the source of supply. The windings of motors, or transformers, or of other equipment directly connected to capacitors without a switch or overcurrent device interposed shall meet the requirements of (a) above.

## ARTICLE 470 — RESISTORS AND REACTORS

For Rheostats, see Section 430-82.

### A. 600 Volts, Nominal, and Under

**470-1. Scope.** This article covers the installation of separate resistors and reactors on electric circuits.

*Exception: Resistors and reactors that are component parts of other apparatus.*

This article also covers the installation of resistors and reactors in hazardous (classified) locations as modified by Articles 501 through 503.

**470-2. Location.** Resistors and reactors shall not be placed where exposed to physical damage.

**470-3. Space Separation.** A thermal barrier shall be required if the space between the resistors and reactors and any combustible material is less than 12 inches (305 mm).

**470-4. Conductor Insulation.** Insulated conductors used for connections between resistance elements and controllers shall be suitable for an operating temperature of not less than 90°C (194°F).

*Exception: Other conductor insulations shall be permitted for motor starting service.*

### B. Over 600 Volts, Nominal

#### 470-18. General.

(a) **Protected Against Physical Damage.** Resistors and reactors shall be protected against physical damage.

(b) **Isolated by Enclosure or Elevation.** Resistors and reactors shall be isolated by enclosure or elevation to protect personnel from accidental contact with energized parts.

(c) **Combustible Materials.** Resistors and reactors shall not be installed in close enough proximity to combustible materials to constitute a fire hazard and in no case closer than within 1 foot (305 mm) of combustible materials.

(d) **Clearances.** Clearances from resistors and reactors to grounded surfaces shall be adequate for the voltage involved.

(FPN): See Article 710.

(e) **Temperature Rise from Induced Circulating Currents.** Metallic enclosures of reactors and adjacent metal parts shall be installed so that the

temperature rise from induced circulating currents will not be hazardous to personnel or constitute a fire hazard.

**470-19. Grounding.** Resistor and reactor cases or enclosures shall be grounded in accordance with Article 250.

**470-20. Oil-Filled Reactors.** Installation of oil-filled reactors, in addition to the above requirements, shall comply with applicable requirements of Article 450.

## ARTICLE 480 — STORAGE BATTERIES

**480-1. Scope.** The provisions of this article shall apply to all stationary installations of storage batteries.

**480-2. Definitions.**

**Storage Battery:** A battery comprised of one or more rechargeable cells of the lead-acid, nickel-cadmium, or other rechargeable electrochemical types.

**Sealed Cell or Battery:** A sealed cell or battery is one which has no provision for the addition of water or electrolyte or for external measurement of electrolyte specific gravity. The individual cells shall be permitted to contain a venting arrangement as described in Section 480-9(b).

**Nominal Battery Voltage:** The voltage computed on the basis of 2.0 volts per cell for the lead-acid type and 1.2 volts per cell for the alkali type.

**480-3. Wiring and Equipment Supplied from Batteries.** Wiring and equipment supplied from storage batteries shall be subject to the requirements of this Code applying to wiring and equipment operating at the same voltage.

*Exception: As otherwise provided for communication systems in Article 800.*

**480-4. Grounding.** The requirements of Article 250 shall apply.

**480-5. Insulation of Batteries of Not Over 250 Volts.** This section shall apply to storage batteries having cells so connected as to operate at a nominal battery voltage of not over 250 volts.

(a) **Vented Lead-Acid Batteries.** Cells and multicompartiment batteries with covers sealed to containers of nonconductive, heat-resistant material shall not require additional insulating support.

(b) **Vented Alkaline-type Batteries.** Cells with covers sealed to jars of nonconductive, heat-resistant material shall require no additional insulation support. Cells in jars of conductive material shall be installed in trays of nonconductive material with not more than 20 cells (24 volts, nominal) in the series circuit in any one tray.

(c) **Rubber Jars.** Cells in rubber or composition containers shall require no additional insulating support where the total nominal voltage of all cells in series does not exceed 150 volts. Where the total voltage exceeds 150 volts, batteries shall be sectionalized into groups of 150 volts or less and each group shall have the individual cells installed in trays or on racks.



(d) **Sealed Cells or Batteries.** Sealed cells and multicompart ment sealed batteries constructed of nonconductive, heat-resistant material shall not require additional insulating support. Batteries constructed of a conducting container shall have insulating support if a voltage is present between the container and ground.

**480-6. Insulation of Batteries of Over 250 Volts.** The provisions of Section 480-5 shall apply to storage batteries having the cells so connected as to operate at a nominal voltage exceeding 250 volts, and, in addition, the provisions of this section shall also apply to such batteries. Cells shall be installed in groups having a total nominal voltage of not over 250 volts on any one rack. Insulation, which can be air, shall be provided between racks and shall have a minimum separation between live battery parts of opposite polarity of 2 inches (50.8 mm) for battery voltages not exceeding 600 volts. Maximum protection can be secured by sectionalizing high-voltage batteries into groups.

**480-7. Racks and Trays.** Racks and trays shall comply with (a) and (b) below.

(a) **Racks.** Racks, as required in this article, are rigid frames designed to support cells or trays. They shall be substantial and made of:

(1) Metal, so treated as to be resistant to deteriorating action by the electrolyte and provided with nonconducting members directly supporting the cells or with continuous insulating material other than paint or conducting members; or

(2) Other construction such as fiberglass or other suitable nonconductive materials.

(b) **Trays.** Trays are frames, such as crates or shallow boxes usually of wood or other nonconductive material, so constructed or treated as to be resistant to deteriorating action by the electrolyte.

**480-8. Battery Locations.** Battery locations shall conform to (a) and (b) below.

(a) **Ventilation.** Provisions shall be made for sufficient diffusion and ventilation of the gases from the battery to prevent the accumulation of an explosive mixture.

(b) **Live Parts.** Guarding of live parts shall comply with Section 110-17.

**480-9. Vents.**

(a) **Vented Cells.** Each vented cell shall be equipped with a flame arrestor designed to prevent destruction of the cell due to ignition of gases within the cell by an external spark or flame under normal operating conditions.

(b) **Sealed Cells.** Sealed battery/cells shall be equipped with a pressure-release vent to prevent excessive accumulation of gas pressure or the battery/cell shall be designed to prevent scatter of cell parts in event of a cell explosion.

## Chapter 5. Special Occupancies

### ARTICLE 500 — HAZARDOUS (CLASSIFIED) LOCATIONS

**500-1. Scope — Articles 500 Through 503.** Articles 500 through 503 cover the requirements for electrical equipment and wiring for all voltages in locations where fire or explosion hazards may exist due to flammable gases or vapors, flammable liquids, combustible dust, or ignitable fibers or flyings.

**500-2. Location and General Requirements.** Locations are classified depending on the properties of the flammable vapors, liquids or gases, or combustible dusts or fibers which may be present and the likelihood that a flammable or combustible concentration or quantity is present. Where pyrophoric materials are the only materials used or handled, these locations shall not be classified.

Each room, section, or area shall be considered individually in determining its classification.

*Exception: Except as modified in Articles 500 through 503, all other applicable rules contained in this Code shall apply to electric equipment and wiring installed in hazardous (classified) locations.*

(FPN No. 1): For definitions of "approved" and "explosionproof" as used in these articles, see Article 100; "dust-ignition-proof" is defined in Section 502-1.

Equipment and associated wiring approved as intrinsically safe shall be permitted in any hazardous (classified) location for which it is approved, and the provisions of Articles 500 through 517 shall not be considered applicable to such installations. Wiring of intrinsically safe circuits shall be physically separated from wiring of all other circuits that are not intrinsically safe. Means shall be provided to prevent the passage of gases and vapors. Intrinsically safe equipment and wiring shall not be capable of releasing sufficient electrical or thermal energy under normal or abnormal conditions to cause ignition of a specific flammable or combustible atmospheric mixture in its most easily ignitable concentration.

Abnormal conditions shall include accidental damage to any field-installed wiring, failure of electrical components, application of overvoltage, adjustment and maintenance operations, and other similar conditions.

(FPN No. 2): For further information, see *Intrinsically Safe Apparatus and Associated Apparatus for Use in Class I, II, and III, Division 1 Hazardous Locations*, NFPA 493-1978 (ANSI) and *Installation of Intrinsically Safe Instrument Systems in Class I Hazardous Locations* (ANSI/ISA RP 12.6-1976).

(FPN No. 3): Through the exercise of ingenuity in the layout of electrical installations for hazardous (classified) locations, it is frequently possible to locate much of the equipment in less hazardous or in nonhazardous locations and thus to reduce the amount of special equipment required. In some cases, hazards may be reduced or hazardous (classified) locations limited or eliminated by adequate positive-pressure ventilation from a source of clean air in conjunction with effective safeguards against ventilation failure. For further information, see *Purged and Pressurized Enclosures for Electrical Equipment in Hazardous Locations*, NFPA 496-1982 (ANSI).

(FPN No. 4): It is important that the authority having jurisdiction be familiar with such recorded industrial experience as well as with such standards of the National Fire Protection Association as may be of use in the classification of various areas with respect to hazard.

(FPN No. 5): For further information, see Flammable and Combustible Liquids Code, NFPA 30-1984; Drycleaning Plants, NFPA 32-1985; Manufacture of Organic Coatings, NFPA 35-1982 (ANSI); Solvent Extraction Plants, NFPA 36-1985 (ANSI); Storage and Handling of Liquefied Petroleum Gases, NFPA 58-1986; Storage and Handling of Liquefied Petroleum Gases at Utility Gas Plants, NFPA 59-1984; and Classification of Class I Hazardous Locations for Electrical Installations in Chemical Plants, NFPA 497A-1986 (ANSI).

(FPN No. 6): For protection against static electricity hazards, see Recommended Practice on Static Electricity, NFPA 77-1983 (ANSI).

(FPN No. 7): For electrical classification of laboratory areas, see Standard for Fire Protection of Laboratories Using Chemicals, NFPA 45-1982.

All conduit referred to herein shall be threaded with a NPT standard conduit cutting die that provides  $\frac{3}{4}$ -inch taper per foot. Such conduit shall be made up wrenchtight to minimize sparking when fault current flows through the conduit system. Where it is impractical to make a threaded joint tight, a bonding jumper shall be utilized.

**500-3. Special Precaution.** Articles 500 through 503 require equipment construction and installation that will ensure safe performance under conditions of proper use and maintenance.

(FPN No. 1): It is important that inspection authorities and users exercise more than ordinary care with regard to installation and maintenance.

(FPN No. 2): The explosion characteristics of air mixtures of gases, vapors, or dusts vary with the specific material involved. For Class I locations, Groups A, B, C, and D, the classification involves determinations of maximum explosion pressure, maximum safe clearance between parts of a clamped joint in an enclosure, and the minimum ignition temperature of the atmospheric mixture. For Class II locations, Groups E, F, and G, the classification involves the tightness of the joints of assembly and shaft openings, to prevent entrance of dust in the dust-ignition-proof enclosure, the blanketing effect of layers of dust on the equipment that may cause overheating, electrical conductivity of the dust, and the ignition temperature of the dust. It is necessary, therefore, that equipment be approved not only for the class, but also for the specific group of the gas, vapor, or dust that will be present.

(FPN No. 3): Low ambient conditions require special consideration. Explosionproof or dust-ignition-proof equipment may not be suitable for use at temperatures lower than  $-25^{\circ}\text{C}$  ( $-13^{\circ}\text{F}$ ) unless they are approved for low-temperature service. However at low ambient temperatures flammable concentrations of vapors may not exist in a location classified Class I, Division 1 at normal ambient temperature.

(FPN No. 4): For purposes of testing, approval, and area classification, various air mixtures (not oxygen-enriched) have been grouped on the basis of their characteristics and facilities have been made available for testing and approving equipment for use in the following atmospheric groups:

(FPN No. 5): Group A: Atmospheres containing acetylene.

(FPN No. 6): Group B: Atmospheres such as butadiene,\* ethylene oxide,\*\* propylene oxide,\*\* acrolein,\*\* or hydrogen (or gases or vapors equivalent in hazard to hydrogen, such as manufactured gas).

(FPN No. 7): Group C: Atmospheres such as cyclopropane, ethyl ether, ethylene, or gases or vapors of equivalent hazard.

(FPN No. 8): Group D: Atmospheres such as acetone, alcohol, ammonia,\*\*\* benzene, benzol, butane, gasoline, hexane, lacquer solvent vapors, naphtha, natural gas, propane, or gases or vapors of equivalent hazard.

(FPN No. 9): \*Group D equipment may be used for this atmosphere if such equipment is isolated in accordance with Section 501-5(a) by sealing all conduit 1/2-inch size or larger.

(FPN No. 10): \*\*Group C equipment may be used for this atmosphere if such equipment is isolated in accordance with Section 501-5(a) by sealing all conduit 1/2-inch size or larger.

(FPN No. 11): \*\*\*For classification of areas involving ammonia atmosphere, see Safety Code for Mechanical Refrigeration (ANSI/ASHRAE 15-1978) and Safety Requirements for the Storage and Handling of Anhydrous Ammonia (ANSI/CGA G2.1-1981).

(FPN No. 12): For properties of flammable liquids, gases, and solids, see Classification of Gases, Vapors and Dusts for Electrical Equipment in Hazardous (Classified) Locations, NFPA 497M-1986, and Fire Hazard Properties of Flammable Liquids, Gases, and Volatile Solids, NFPA 325M-1984.

(FPN No. 13): Group E: Atmospheres containing combustible metal dusts regardless of resistivity, or other combustible dusts of similarly hazardous characteristics having resistivity of less than  $10^5$  ohm-centimeter.

(FPN No. 14): Group F: Atmospheres containing carbon black, charcoal, coal or coke dusts which have more than 8 percent total volatile material (carbon black per ASTM D1620; charcoal, coal and coke dusts per ASTM D271) or atmospheres containing these dusts sensitized by other materials so that they present an explosion hazard, and having resistivity greater than  $10^2$  ohm-centimeter but equal to or less than  $10^8$  ohm-centimeter.

(FPN No. 15): Group G: Atmospheres containing combustible dusts having resistivity of  $10^5$  ohm-centimeter or greater.

(FPN No. 16): Certain chemical atmospheres may have characteristics that require safeguards beyond those required for any of the above groups. Carbon disulfide is one of these chemicals because of its low ignition temperature, 100°C (212°F), and the small joint clearance to arrest its flame.

(FPN No. 17): Certain metal dusts may have characteristics that require safeguards beyond those required for atmospheres containing the dusts of aluminum, magnesium, and their commercial alloys. For example, zirconium, thorium and uranium dusts have extremely low ignition temperatures [as low as 20°C (68°F)], and minimum ignition energies lower than any material classified in any of the Class I or Class II Groups.

(FPN No. 18): Certain dusts may require additional precautions due to chemical phenomena that can result in the generation of ignitable gases. See National Electrical Safety Code (ANSI C2-1984), Section 127A-Coal Handling Areas.

**(a) Approval for Class and Properties.** Equipment shall be approved not only for the class of location but also for the explosive, combustible, or ignitable properties of the specific gas, vapor, dust, fiber, or flyings that will be present. In addition, Class I equipment shall not have any exposed surface that operates at a temperature in excess of the ignition temperature of the specific gas or vapor. Class II equipment shall not have an external temperature higher than that specified in Section 500-3(d). Class III equipment shall not exceed the maximum surface temperatures specified in Section 503-1.

Equipment that has been approved for a Division 1 location shall be permitted in a Division 2 location of the same class and group.

Where specifically permitted in Articles 501 through 503, general-purpose equipment or equipment in general-purpose enclosures shall be permitted to be installed in Division 2 locations if the equipment does not constitute a source of ignition under normal operating conditions.

Unless otherwise specified, normal operating conditions for motors shall be assumed to be rated full-load steady conditions.

Where flammable gases or combustible dusts are or may be present at the same time, the simultaneous presence of both shall be considered when determining the safe operating temperature of the electrical equipment.

(FPN): The characteristics of various atmospheric mixtures of gases, vapors, and dusts depend on the specific material involved.

**(b) Marking.** Approved equipment shall be marked to show the Class, Group, and operating temperature or temperature range referenced to a 40°C ambient.

The temperature range, if provided, shall be indicated in identification numbers, as shown in Table 500-3(b).

Identification numbers marked on equipment nameplates shall be in accordance with Table 500-3(b).

Equipment which is approved for Class I and Class II shall be marked with the maximum safe operating temperature, as determined by simultaneous exposure to the combinations of Class I and Class II conditions.

*Exception No. 1: Equipment of the nonheat-producing type, such as junction boxes, conduit, and fittings and equipment of the heat-producing type having a maximum temperature not more than 100°C (212°F), shall not be required to have a marked operating temperature or temperature range.*

*Exception No. 2: Fixed lighting fixtures marked for use in Class I, Division 2 or Class II, Division 2 locations only shall not be required to be marked to indicate the group.*

*Exception No. 3: Fixed general-purpose equipment in Class I locations, other than fixed lighting fixtures, which is acceptable for use in Class I, Division 2 locations shall not be required to be marked with the Class, Group, Division or operating temperature.*

*Exception No. 4: Fixed dusttight equipment other than fixed lighting fixtures which are acceptable for use in Class II, Division 2 and Class III locations shall not be required to be marked with the Class, Group, Division or operating temperature.*

(FPN): For purposes of testing and approval, various atmospheric mixtures (not oxygen-enriched) have been grouped on the basis of their characteristics, and facilities have been made available for testing and approving equipment for use in the atmospheric groups listed in Classification of Gases, Vapors, and Dusts for Electrical Equipment in Hazardous (Classified) Locations, NFPA 497M-1986. Since there is no consistent relationship between explosion properties and ignition temperature, the two are independent requirements.

**(c) Class I Temperature.** The temperature marking specified in (b) above shall not exceed the ignition temperature of the specific gas or vapor to be encountered.

(FPN): For information regarding ignition temperatures of gases and vapors, see Classification of Gases, Vapors, and Dusts for Electrical Equipment in Hazardous (Classified) Locations, NFPA 497M-1986, and Fire Hazard Properties of Flammable Liquids, Gases, and Volatile Solids, NFPA 325M-1984.

Table 500-3(b). Identification Numbers

Degrees C	Maximum Temperature Degrees F	Identification Number
450	842	T1
300	572	T2
280	536	T2A
260	500	T2B
230	446	T2C
215	419	T2D
200	392	T3
180	356	T3A
165	329	T3B
160	320	T3C
135	275	T4
120	248	T4A
100	212	T5
85	185	T6

Formerly the temperature limit of each Group was assumed to be the lowest ignition temperature of any material in the Group, i.e., 280°C for Group D, 180°C for Group C.

(FPN): To avoid revising this limit as new gases are added (see hexane in Group D and acetaldehyde in Group C), temperature will be specified in future markings.

The ignition temperature for which equipment was approved prior to this requirement shall be assumed to be as follows:

Group A — 280°C (536°F)	Group C — 180°C (356°F)
Group B — 280°C (536°F)	Group D — 280°C (536°F)

(d) **Class II Temperature.** The surface temperature marking specified in (b) above shall be less than the ignition temperature of the specific dust and in no case shall it be greater than the temperature given below for Groups E, F, and G. (See Classification of Gases, Vapors, and Dusts for Electrical Equipment in Hazardous (Classified) Locations, NFPA 497M-1986 for minimum ignition temperatures of specific dusts.)

*Exception: Equipment subject to overloads shall not exceed 150°C (302°F) in normal operation and shall not exceed the ignition temperature of the specific dust or 200°C (392°F), whichever is lower, when installed in locations which are classified due to carbonaceous dusts.*

The maximum surface temperature for which equipment was approved prior to this requirement shall be assumed to be as follows:

Class II Group	Equipment that Is Not Subject to Overloading		Equipment (such as Motors or Power Transformers) that May Be Overloaded			
	Degrees C	Degrees F	Normal Operation		Abnormal Operation	
	Degrees C	Degrees F	Degrees C	Degrees F	Degrees C	Degrees F
E	200	392	200	392	200	392
F	200	392	150	302	200	392
G	165	329	120	248	165	329

**500-4. Specific Occupancies.** Articles 510 through 517 cover garages, aircraft hangars, gasoline dispensing and service stations, bulk storage plants, spray application, dipping and coating processes, and health care facilities.

**500-5. Class I Locations.** Class I locations are those in which flammable gases or vapors are or may be present in the air in quantities sufficient to produce explosive or ignitable mixtures. Class I locations shall include those specified in (a) and (b) below.

**(a) Class I, Division 1.** A Class I, Division 1 location is a location: (1) in which ignitable concentrations of flammable gases or vapors can exist under normal operating conditions; or (2) in which ignitable concentrations of such gases or vapors may exist frequently because of repair or maintenance operations or because of leakage; or (3) in which breakdown or faulty operation of equipment or processes might release ignitable concentrations of flammable gases or vapors, and might also cause simultaneous failure of electric equipment.

(FPN): This classification usually includes locations where volatile flammable liquids or liquefied flammable gases are transferred from one container to another; interiors of spray booths and areas in the vicinity of spraying and painting operations where volatile flammable solvents are used; locations containing open tanks or vats of volatile flammable liquids; drying rooms or compartments for the evaporation of flammable solvents; locations containing fat and oil extraction equipment using volatile flammable solvents; portions of cleaning and dyeing plants where flammable liquids are used; gas generator rooms and other portions of gas manufacturing plants where flammable gas may escape; inadequately ventilated pump rooms for flammable gas or for volatile flammable liquids; the interiors of refrigerators and freezers in which volatile flammable materials are stored in open, lightly stoppered, or easily ruptured containers; and all other locations where ignitable concentrations of flammable vapors or gases are likely to occur in the course of normal operations.

**(b) Class I, Division 2.** A Class I, Division 2 location is a location: (1) in which volatile flammable liquids or flammable gases are handled, processed, or used, but in which the liquids, vapors, or gases will normally be confined within closed containers or closed systems from which they can escape only in case of accidental rupture or breakdown of such containers or systems, or in case of abnormal operation of equipment; or (2) in which ignitable concentrations of gases or vapors are normally prevented by positive mechanical ventilation, and which might become hazardous through failure or abnormal operation of the ventilating equipment; or (3) that is adjacent to a Class I, Division 1 location, and to which ignitable concentrations of gases or vapors might occasionally be communicated unless such communication is prevented by adequate positive-pressure ventilation from a source of clean air, and effective safeguards against ventilation failure are provided.

(FPN): This classification usually includes locations where volatile flammable liquids or flammable gases or vapors are used, but which, in the judgment of the authority having jurisdiction, would become hazardous only in case of an accident or of some unusual operating condition. The quantity of flammable material that might escape in case of accident, the adequacy of ventilating equipment, the total area involved, and the record of the industry or business with respect to explosions or fires are all factors that merit consideration in determining the classification and extent of each location.

(FPN): Piping without valves, checks, meters, and similar devices would not ordinarily introduce a hazardous condition even though used for flammable liquids

or gases. Locations used for the storage of flammable liquids or of liquefied or compressed gases in sealed containers would not normally be considered hazardous unless subject to other hazardous conditions also.

Electrical conduits and their associated enclosures separated from process fluids by a single seal or barrier shall be classed as a Division 2 location if the outside of the conduit and enclosures is a nonhazardous location.

**500-6. Class II Locations.** Class II locations are those that are hazardous because of the presence of combustible dust. Class II locations shall include those specified in (a) and (b) below.

**(a) Class II, Division 1.** A Class II, Division 1 location is a location: (1) in which combustible dust is in the air under normal operating conditions in quantities sufficient to produce explosive or ignitable mixtures; or (2) where mechanical failure or abnormal operation of machinery or equipment might cause such explosive or ignitable mixtures to be produced, and might also provide a source of ignition through simultaneous failure of electric equipment, operation of protection devices, or from other causes; or (3) in which combustible dusts of an electrically conductive nature may be present in hazardous quantities.

(FPN): Combustible dusts which are electrically nonconductive include dusts produced in the handling and processing of grain and grain products, pulverized sugar and cocoa, dried egg and milk powders, pulverized spices, starch and pastes, potato and woodflour, oil meal from beans and seed, dried hay, and other organic materials which may produce combustible dusts when processed or handled. Electrically conductive dusts are dusts with a resistivity less than  $10^5$  ohm-centimeter. Dusts containing magnesium or aluminum are particularly hazardous and the use of extreme precaution will be necessary to avoid ignition and explosion.

**(b) Class II, Division 2.** A Class II Division 2 location is a location where combustible dust is not normally in the air in quantities sufficient to produce explosive or ignitable mixtures, and dust accumulations are normally insufficient to interfere with the normal operation of electrical equipment or other apparatus, but combustible dust may be in suspension in the air as a result of infrequent malfunctioning of handling or processing equipment and where combustible dust accumulations on, in, or in the vicinity of the electrical equipment may be sufficient to interfere with the safe dissipation of heat from electrical equipment or may be ignitable by abnormal operation or failure of electrical equipment.

(FPN): The quantity of combustible dust that may be present and the adequacy of dust removal systems are factors that merit consideration in determining the classification and may result in an unclassified area.

(FPN): Where products such as seed are handled in a manner which produces low quantities of dust, the amount of dust deposited may not warrant classification.

**500-7. Class III Locations.** Class III locations are those that are hazardous because of the presence of easily ignitable fibers or flyings, but in which such fibers or flyings are not likely to be in suspension in the air in quantities sufficient to produce ignitable mixtures. Class III locations shall include those specified in (a) and (b) below.

**(a) Class III, Division 1.** A Class III, Division 1 location is a location in which easily ignitable fibers or materials producing combustible flyings are handled, manufactured, or used.



(FPN): Such locations usually include some parts of rayon, cotton, and other textile mills; combustible fiber manufacturing and processing plants; cotton gins and cotton-seed mills; flax-processing plants; clothing manufacturing plants; woodworking plants; and establishments and industries involving similar hazardous processes or conditions.

(FPN): Easily ignitable fibers and flyings include rayon, cotton (including cotton linters and cotton waste), sisal or henequen, istle, jute, hemp, tow, cocoa fiber, oakum, baled waste kapok, Spanish moss, excelsior, and other materials of similar nature.

**(b) Class III, Division 2.** A Class III, Division 2 location is a location in which easily ignitable fibers are stored or handled.

*Exception: In process of manufacture.*

## ARTICLE 501 — CLASS I LOCATIONS

**501-1. General.** The general rules of this Code shall apply to the electric wiring and equipment in locations classified as Class I in Section 500-5.

*Exception: As modified by this article.*

**501-2. Transformers and Capacitors.**

**(a) Class I, Division 1.** In Class I, Division 1 locations, transformers and capacitors shall comply with the following:

**(1) Containing Liquid that Will Burn.** Transformers and capacitors containing a liquid that will burn shall be installed only in approved vaults that comply with Sections 450-41 through 450-48, and in addition: (1) there shall be no door or other communicating opening between the vault and the Division 1 location; and (2) ample ventilation shall be provided for the continuous removal of flammable gases or vapors; and (3) vent openings or ducts shall lead to a safe location outside of buildings; and (4) vent ducts and openings shall be of sufficient area to relieve explosion pressures within the vault, and all portions of vent ducts within the buildings shall be of reinforced concrete construction.

**(2) Not Containing Liquid that Will Burn.** Transformers and capacitors that do not contain a liquid that will burn shall: (1) be installed in vaults complying with (a)(1) above, or (2) be approved for Class I locations.

**(b) Class I, Division 2.** In Class I, Division 2 locations, transformers and capacitors shall comply with Sections 450-21 through 450-27.

**501-3. Meters, Instruments, and Relays.**

**(a) Class I, Division 1.** In Class I, Division 1 locations, meters, instruments, and relays, including kilowatt-hour meters, instrument transformers, resistors, rectifiers, and thermionic tubes, shall be provided with enclosures approved for Class I, Division 1 locations.

Enclosures approved for Class I, Division 1 locations include: (1) explosionproof enclosures, and (2) purged and pressurized enclosures.

(FPN): See NFPA 496-1982 (ANSI), Purged and Pressurized Enclosures for Electrical Equipment in Hazardous Locations.

**(b) Class I, Division 2.** In Class I, Division 2 locations, meters, instruments, and relays shall comply with the following:

**(1) Contacts.** Switches, circuit breakers, and make-and-break contacts of pushbuttons, relays, alarm bells, and horns shall have enclosures approved for Class I, Division 1 locations in accordance with (a) above.

*Exception: General-purpose enclosures shall be permitted, if current-interrupting contacts are:*

- a. Immersed in oil; or,*
- b. Enclosed within a chamber hermetically sealed against the entrance of gases or vapors; or,*
- c. In circuits that under normal conditions do not release sufficient energy to ignite a specific ignitable atmospheric mixture; i.e., are nonincendive.*

**(2) Resistors and Similar Equipment.** Resistors, resistance devices, thermionic tubes, rectifiers, and similar equipment that is used in or in connection with meters, instruments, and relays shall comply with (a) above.

*Exception: General-purpose-type enclosures shall be permitted if such equipment is without make-and-break or sliding contacts (other than as provided in (b)(1) above) and if the maximum operating temperature of any exposed surface will not exceed 80 percent of the ignition temperature in degrees Celsius of the gas or vapor involved or has been tested and found incapable of igniting the gas or vapor.*

**(3) Without Make-or-Break Contacts.** Transformer windings, impedance coils, solenoids, and other windings that do not incorporate sliding or make-or-break contacts shall be provided with enclosures. General-purpose type enclosures shall be permitted.

**(4) General-Purpose Assemblies.** Where an assembly is made up of components for which general-purpose enclosures are acceptable as provided in (b)(1), (b)(2), and (b)(3) above, a single general-purpose enclosure shall be acceptable for the assembly. Where such an assembly includes any of the equipment described in (b)(2) above, the maximum obtainable surface temperature of any component of the assembly shall be clearly and permanently indicated on the outside of the enclosure. Alternatively, approved equipment shall be permitted to be marked to indicate the temperature range for which it is suitable, using the identification numbers of Table 500-3(b).

**(5) Fuses.** Where general-purpose enclosures are permitted in (b)(1), (b)(2), (b)(3) and (b)(4) above, fuses for overcurrent protection of instrument circuits not subject to overloading in normal use shall be permitted to be mounted in general-purpose enclosures if each such fuse is preceded by a switch complying with (b)(1) above.

**(6) Connections.** To facilitate replacements, process control instruments shall be permitted to be connected through flexible cord, attachment plug, and receptacle, provided: (1) a switch complying with (b)(1) above is provided so that the attachment plug is not depended on to interrupt current; and (2) the current does not exceed 3 amperes at 120 volts, nominal; and (3) the power-supply cord does not exceed 3 feet (914 mm), is of a type approved for extra-hard usage or for hard usage if protected by location; and is supplied through an attachment plug and receptacle of the locking and grounding type; and (4) only necessary receptacles are provided; and (5) the receptacle carries a label warning against unplugging under load.

**501-4. Wiring Methods.** Wiring methods shall comply with (a) and (b) below.

(a) **Class I, Division 1.** In Class I, Division 1 locations, threaded rigid metal conduit, threaded steel intermediate metal conduit, or Type MI cable with termination fittings approved for the location shall be the wiring method employed. All boxes, fittings, and joints shall be threaded for connection to conduit or cable terminations, and shall be explosionproof. Threaded joints shall be made up with at least five threads fully engaged. Type MI cable shall be installed and supported in a manner to avoid tensile stress at the termination fittings. Where necessary to employ flexible connections, as at motor terminals, flexible fittings approved for Class I locations shall be used.

(b) **Class I, Division 2.** In Class I, Division 2 locations, threaded rigid metal conduit, threaded steel intermediate metal conduit, enclosed gasketed busways, enclosed gasketed wireways, or Type PLTC cable in accordance with the provisions of Article 725, Type MI, MC, MV, TC, or SNM cable with approved termination fittings shall be the wiring method employed. Type PLTC, MI, MC, MV, TC, or SNM cable shall be permitted to be installed in cable tray systems and shall be installed in a manner to avoid tensile stress at the termination fittings. Boxes, fittings, and joints shall not be required to be explosionproof except as required by Sections 501-3(b)(1), 501-6(b)(1), and 501-14(b)(1). Where provision must be made for limited flexibility, as at motor terminals, flexible metal fittings, flexible metal conduit with approved fittings, liquidtight flexible metal conduit with approved fittings, or flexible cord approved for extra-hard usage and provided with approved bushed fittings shall be used. An additional conductor for grounding shall be included in the flexible cord unless other acceptable means of grounding are provided.

*Exception: Wiring, which under normal conditions cannot release sufficient energy to ignite a specific ignitable atmospheric mixture by opening, shorting or grounding, shall be permitted using any of the methods suitable for wiring in ordinary locations.*

**501-5. Sealing and Drainage.** Seals in conduit and cable systems shall comply with (a) through (f) below. Sealing compound shall be of a type approved for the conditions and use. Sealing compound shall be used in Type MI cable termination fittings to exclude moisture and other fluids from the cable insulation.

(FPN): Seals are provided in conduit and cable systems to minimize the passage of gases and vapors and prevent the passage of flames from one portion of the electrical installation to another through the conduit. Such communication through Type MI cable is inherently prevented by construction of the cable. Unless specifically designed and tested for the purpose, conduit and cable seals are not intended to prevent the passage of liquids, gases or vapors at a continuous pressure differential across the seal. Even at differences in pressure across the seal equivalent to a few inches of water, there may be a slow passage of gas or vapor through a seal, and through conductors passing through the seal. See Section 501-5(e)(2). Temperature extremes and highly corrosive liquids and vapors can affect the ability of seals to perform their intended function. See Section 501-5(c)(2).

(a) **Conduit Seals, Class I, Division 1.** In Class I, Division 1 locations, conduit seals shall be located as follows:

(1) In each conduit run entering an enclosure for switches, circuit breakers, fuses, relays, resistors, or other apparatus which may produce arcs, sparks, or high temperatures. Seals shall be placed as close as practicable and in no case more than 18 inches (457 mm) from such enclosures. Explosionproof unions, couplings, elbows, capped elbows and conduit bodies similar to "L," "T," and "Cross" type shall be the only enclosures or fittings permitted between the sealing fitting and the enclosure. The conduit bodies shall not be larger than the largest trade size of the conduits.

*Exception: Conduit 1½ inches and smaller entering an explosionproof enclosure for switches, circuit breakers, fuses, relays, or other apparatus which may produce arcs or sparks shall not be required to be sealed if the current-interrupting contacts are:*

a. Enclosed within a chamber hermetically sealed against the entrance of gases or vapors, or,

b. Immersed in oil in accordance with Section 501-6(b)(1)(2).

(2) In each conduit of 2-inch size or larger entering the enclosure or fitting housing terminals, splices, or taps and within 18 inches (457 mm) of such enclosure or fitting.

(FPN): See notes under Group B in sixth Fine Print Note to Section 500-3.

(3) Where two or more enclosures for which seals are required under (a)(1) and (a)(2) above are connected by nipples or by runs of conduit not more than 36 inches (914 mm) long, a single seal in each such nipple connection or run of conduit shall be considered sufficient if located not more than 18 inches (457 mm) from either enclosure.

(4) In each conduit run leaving the Class I, Division 1 location. The sealing fitting shall be permitted on either side of the boundary of such location but shall be so designed and installed to minimize the amount of gas or vapor which may have entered the conduit system within the Division 1 location from being communicated to the conduit beyond the seal. There shall be no union, coupling, box, or fitting in the conduit between the sealing fitting and the point at which the conduit leaves the Division 1 location.

*Exception: Metal conduit containing no unions, couplings, boxes, or fittings that passes completely through a Class I, Division 1 location with no fittings less than 12 inches (305 mm) beyond each boundary shall not be required to be sealed if the termination points of the unbroken conduit are in nonhazardous locations.*

**(b) Conduit Seals, Class I, Division 2.** In Class I, Division 2 locations, conduit seals shall be located as follows:

(1) For connections to explosionproof enclosures that are required to be approved for Class I locations, seals shall be provided in accordance with (a)(1), (a)(2) and (a)(3) above. All portions of the conduit run or nipple between the seal and such enclosure shall comply with Section 501-4(a).

(2) In each conduit run passing from a Class I, Division 2 location into a nonhazardous location. The sealing fitting shall be permitted on either side of the boundary of such location but shall be so designed and installed to minimize the amount of gas or vapor which may have entered the conduit system within the Division 2 location from being communicated to the conduit beyond the seal. Rigid metal conduit or threaded steel intermediate metal conduit shall be used between the sealing fitting and the point at which

the conduit leaves the Division 2 location, and a threaded connection shall be used at the sealing fitting. There shall be no union, coupling, box, or fitting in the conduit between the sealing fitting and the point at which the conduit leaves the Division 2 location.

*Exception: Metal conduit containing no unions, couplings, boxes or fittings that passes completely through a Class I, Division 2 location with no fittings less than 12 inches (305 mm) beyond each boundary shall not be required to be sealed if the termination points of the unbroken conduit are in nonhazardous locations.*

**(c) Class I, Divisions 1 and 2.** Where required, seals in Class I, Division 1 and 2 locations shall comply with the following:

**(1) Fittings.** Enclosures for connections or equipment shall be provided with an approved integral means for sealing, or sealing fittings approved for Class I locations shall be used. Sealing fittings shall be accessible.

**(2) Compound.** Sealing compound shall be approved and shall provide a seal against passage of gas or vapors through the seal fitting, shall not be affected by the surrounding atmosphere or liquids, and shall not have a melting point of less than 93°C (200°F).

**(3) Thickness of Compounds.** In a completed seal, the minimum thickness of the sealing compound shall not be less than the trade size of the conduit, and in no case less than 3/8 inch (16 mm).

**(4) Splices and Taps.** Splices and taps shall not be made in fittings intended only for sealing with compound, nor shall other fittings in which splices or taps are made be filled with compound.

**(5) Assemblies.** In an assembly where equipment that may produce arcs, sparks, or high temperatures is located in a compartment separate from the compartment containing splices or taps, and an integral seal is provided where conductors pass from one compartment to the other, the entire assembly shall be approved for Class I locations. Seals in conduit connections to the compartment containing splices or taps shall be provided in Class I, Division 1 locations where required by (a)(2) above.

**(d) Cable Seals, Class I, Division 1.** In Class I, Division 1 locations each multiconductor cable in conduit shall be considered as a single conductor if the cable is incapable of transmitting gases or vapors through the cable core. These cables shall be sealed in accordance with (a) above.

Cables with a gas/vapor-tight continuous sheath capable of transmitting gases or vapors through the cable core shall be sealed in the Division 1 location after removing the jacket and any other coverings so that the sealing compound will surround each individual insulated conductor and the outer jacket.

**(e) Cable Seals, Class I, Division 2.** In Class I, Division 2 locations, cable seals shall be located as follows:

**(1)** Cables entering enclosures which are required to be approved for Class I locations shall be sealed at the point of entrance. The sealing fitting shall comply with (b)(1) above. Multiconductor cables with a gas/vapor-tight continuous sheath capable of transmitting gases or vapors through the cable core shall be sealed in an approved fitting in the Division 2 location after removing the jacket and any other coverings so that the sealing compound will surround each individual insulated conductor in such a manner as to

minimize the passage of gases and vapors. Multiconductor cables in conduit shall be sealed as described in (d) above.

(2) Cables with a gas/vapor-tight continuous sheath and which will not transmit gases or vapors through the cable core in excess of the quantity permitted for seal fittings shall not be required to be sealed except as required in (e)(1) above. The minimum length of such cable run shall not be less than that length which limits gas or vapor flow through the cable core to the rate permitted for seal fittings [0.007 cubic feet per hour (198 cubic centimeters per hour) of air at a pressure of 6 inches of water (1493 pascals)].

(FPN): See Outlet Boxes and Fittings for Use in Hazardous Locations, ANSI/UL 886-1980.

(FPN): The cable core does not include the interstices of the conductor strands.

(3) Cables with a gas/vapor-tight continuous sheath capable of transmitting gases or vapors through the cable core shall not be required to be sealed except as required in (e)(1) above, unless the cable is attached to process equipment or devices that may cause a pressure in excess of 6 inches (1493 pascals) of water to be exerted at a cable end, in which case a seal, barrier or other means shall be provided to prevent migration of flammables into an unclassified area.

*Exception: Cables with an unbroken gas/vapor-tight continuous sheath shall be permitted to pass through a Class I, Division 2 location without seals.*

(4) Cables which do not have gas/vapor-tight continuous sheath shall be sealed at the boundary of the Division 2 and nonhazardous location in such a manner as to minimize the passage of gases or vapors into a nonhazardous location.

(FPN): The sheath mentioned in (d) and (e) above may be either metal or a nonmetallic material.

**(f) Drainage.**

(1) **Control Equipment.** Where there is a probability that liquid or other condensed vapor may be trapped within enclosures for control equipment or at any point in the raceway system, approved means shall be provided to prevent accumulation or to permit periodic draining of such liquid or condensed vapor.

(2) **Motors and Generators.** Where the authority having jurisdiction judges that there is a probability that liquid or condensed vapor may accumulate within motors or generators, joints and conduit systems shall be arranged to minimize entrance of liquid. If means to prevent accumulation or to permit periodic draining are judged necessary, such means shall be provided at the time of manufacture and shall be considered an integral part of the machine.

(3) **Canned Pumps, Process Connections, Etc.** For canned pumps, process connections for flow, pressure, or analysis measurement, etc., that depend upon a single seal diaphragm or tube to prevent process fluids from entering the electrical conduit system, an additional approved seal, barrier or other means shall be provided to prevent the process fluid from entering the conduit system beyond the additional devices or means, if the primary seal fails.

The additional approved seal or barrier and the interconnecting enclosure shall meet the temperature and pressure conditions to which they will be subjected upon failure of the primary seal unless other approved means are provided to accomplish the purpose above.

Drains, vents or other devices shall be provided so that primary seal leakage will be obvious.

(FPN): See also the last paragraph of Section 500-5(b) and Fine Print Note to Section 501-5.

#### **501-6. Switches, Circuit Breakers, Motor Controllers, and Fuses.**

**(a) Class I, Division 1.** In Class I, Division 1 locations, switches, circuit breakers, motor controllers, and fuses, including pushbuttons, relays, and similar devices, shall be provided with enclosures and the enclosure in each case, together with the enclosed apparatus, shall be approved as a complete assembly for use in Class I locations.

**(b) Class I, Division 2.** Switches, circuit breakers, motor controllers, and fuses in Class I, Division 2 locations shall comply with the following:

**(1) Type Required.** Circuit breakers, motor controllers, and switches intended to interrupt current in the normal performance of the function for which they are installed shall be provided with enclosures approved for Class I, Division 1 locations in accordance with Section 501-3(a), unless general-purpose enclosures are provided and (1) the interruption of current occurs within a chamber hermetically sealed against the entrance of gases and vapors, or (2) the current make-and-break contacts are oil-immersed, and of the general-purpose type having a 2-inch (50.8-mm) minimum immersion for power and a 1-inch (25.4-mm) minimum immersion for control.

**(2) Isolating Switches.** Fused or unfused disconnect and isolating switches for transformers or capacitor banks that are not intended to interrupt current in the normal performance of the function for which they are installed, shall be permitted to be installed in general-purpose enclosures.

**(3) Fuses.** For the protection of motors, appliances, and lamps, other than as provided in (b)(4) below, standard plug or cartridge fuses shall be permitted, provided they are placed within enclosures approved for the location; or fuses shall be permitted if they are within general-purpose enclosures, and if they are of a type in which the operating element is immersed in oil or other approved liquid or the operating element is enclosed within a chamber hermetically sealed against the entrance of gases and vapors.

**(4) Fuses or Circuit Breakers for Overcurrent Protection.** Where not more than ten sets of approved enclosed fuses or not more than ten circuit breakers that are not intended to be used as switches for the interruption of current are installed for branch-circuit or feeder protection in any one room, area, or section of the Class I, Division 2 location, general-purpose-type enclosures for such fuses or circuit breakers shall be permitted if the fuses or circuit breakers are for the protection of circuits or feeders supplying lamps in fixed positions only.

(FPN): A set of fuses is all the fuses required to protect all the ungrounded conductors of a circuit. For example, a group of three fuses protecting an ungrounded 3-phase circuit and a single fuse protecting the ungrounded conductor of an identified 2-wire single-phase circuit is a set of fuses in each instance.

Fuses complying with (b)(3) above shall not be required to be included in counting the ten sets of fuses permitted in general-purpose enclosures.

(5) **Fuses Internal to Lighting Fixtures.** Approved cartridge fuses shall be permitted as supplementary protection within lighting fixtures.

**501-7. Control Transformers and Resistors.** Transformers, impedance coils, and resistors used as, or in conjunction with, control equipment for motors, generators, and appliances shall comply with (a) and (b) below.

(a) **Class I, Division 1.** In Class I, Division 1 locations, transformers, impedance coils, and resistors, together with any switching mechanism associated with them, shall be provided with enclosures approved for Class I, Division 1 locations in accordance with Section 501-3(a).

(b) **Class I, Division 2.** In Class I, Division 2 locations, control transformers and resistors shall comply with the following:

(1) **Switching Mechanisms.** Switching mechanisms used in conjunction with transformers, impedance coils, and resistors shall comply with Section 501-6(b).

(2) **Coils and Windings.** Enclosures for windings of transformers, solenoids, or impedance coils shall be permitted to be of the general-purpose type.

(3) **Resistors.** Resistors shall be provided with enclosures; and the assembly shall be approved for Class I locations, unless resistance is nonvariable and maximum operating temperature, in degrees Celsius, will not exceed 80 percent of the ignition temperature of the gas or vapor involved, or has been tested and found incapable of igniting the gas or vapor.

#### **501-8. Motors and Generators.**

(a) **Class I, Division 1.** In Class I, Division 1 locations, motors, generators, and other rotating electric machinery shall be: (1) approved for Class I, Division 1 locations; or (2) of the totally enclosed type supplied with positive-pressure ventilation from a source of clean air with discharge to a safe area, so arranged to prevent energizing of the machine until ventilation has been established and the enclosure has been purged with at least 10 volumes of air; and also arranged to automatically de-energize the equipment when the air supply fails; or (3) of the totally enclosed inert gas-filled type supplied with a suitable reliable source of inert gas for pressuring the enclosure, with devices provided to ensure a positive pressure in the enclosure and arranged to automatically de-energize the equipment when the gas supply fails; or (4) of a type designed to be submerged in a liquid which is flammable only when vaporized and mixed with air, or in a gas or vapor at a pressure greater than atmospheric and which is flammable only when mixed with air; and the machine is so arranged to prevent energizing it until it has been purged with the liquid or gas to exclude air, and also arranged to automatically de-energize the equipment when the supply of liquid, or gas or vapor fails or the pressure is reduced to atmospheric.

Totally enclosed motors of Types (2) or (3) shall have no external surface with an operating temperature in degrees Celsius in excess of 80 percent of the ignition temperature of the gas or vapor involved. Appropriate devices shall be provided to detect and automatically de-energize the motor or provide an adequate alarm if there is any increase in temperature of the motor



beyond designed limits. Auxiliary equipment shall be of a type approved for the location in which it is installed.

(FPN): See ASTM Test Procedure (Designation D 2155-69).

**(b) Class I, Division 2.** In Class I, Division 2 locations, motors, generators, and other rotating electric machinery in which are employed sliding contacts, centrifugal or other types of switching mechanism (including motor overcurrent, overloading and overtemperature devices), or integral resistance devices, either while starting or while running, shall be approved for Class I, Division 1 locations, unless such sliding contacts, switching mechanisms, and resistance devices are provided with enclosures approved for Class I, Division 2 locations in accordance with Section 501-3(b). When operated at rated voltage, the exposed surface of space heaters used to prevent condensation of moisture during shut-down periods shall not exceed 80 percent of the ignition temperature in degrees Celsius of the gas or vapor involved.

In Class I, Division 2 locations, the installation of open or nonexplosionproof enclosed motors, such as squirrel-cage induction motors without brushes, switching mechanisms, or similar arc-producing devices shall be permitted.

(FPN): It is important to consider the temperature of internal and external surfaces which may be exposed to the flammable atmosphere.

**501-9. Lighting Fixtures.** Lighting fixtures shall comply with (a) or (b) below.

**(a) Class I, Division 1.** In Class I, Division 1 locations, lighting fixtures shall comply with the following:

**(1) Approved Fixtures.** Each fixture shall be approved as a complete assembly for the Class I, Division 1 location and shall be clearly marked to indicate the maximum wattage of lamps for which it is approved. Fixtures intended for portable use shall be specifically approved as a complete assembly for that use.

**(2) Physical Damage.** Each fixture shall be protected against physical damage by a suitable guard or by location.

**(3) Pendant Fixtures.** Pendant fixtures shall be suspended by and supplied through threaded rigid metal conduit stems or threaded steel intermediate conduit stems, and threaded joints shall be provided with set-screws or other effective means to prevent loosening. For stems longer than 12 inches (305 mm), permanent and effective bracing against lateral displacement shall be provided at a level not more than 12 inches (305 mm) above the lower end of the stem, or flexibility in the form of a fitting or flexible connector approved for the Class I, Division 1 location shall be provided not more than 12 inches (305 mm) from the point of attachment to the supporting box or fitting.

**(4) Supports.** Boxes, box assemblies, or fittings used for the support of lighting fixtures shall be approved for Class I locations.

**(b) Class I, Division 2.** In Class I, Division 2 locations, lighting fixtures shall comply with the following:

**(1) Portable Lighting Equipment.** Portable lighting equipment shall comply with (a)(1) above.

*Exception: Where portable lighting equipment are mounted on movable stands and are connected by flexible cords, as covered in Section 501-11, they shall be permitted, when mounted in any position, provided that they conform to Section 501-9(b)(2) below.*

**(2) Fixed Lighting.** Lighting fixtures for fixed lighting shall be protected from physical damage by suitable guards or by location. Where there is danger that falling sparks or hot metal from lamps or fixtures might ignite localized concentrations of flammable vapors or gases, suitable enclosures or other effective protective means shall be provided. Where lamps are of a size or type that may, under normal operating conditions, reach surface temperatures exceeding 80 percent of the ignition temperature in degrees Celsius of the gas or vapor involved, fixtures shall comply with (a)(1) above or shall be of a type which has been tested and found incapable of igniting the gas or vapor if the ignition temperature is not exceeded.

**(3) Pendant Fixtures.** Pendant fixtures shall be suspended by threaded rigid metal conduit stems, threaded steel intermediate metal conduit stems or by other approved means. For rigid stems longer than 12 inches (305 mm); permanent and effective bracing against lateral displacement shall be provided at a level not more than 12 inches (305 mm) above the lower end of the stem, or flexibility in the form of an approved fitting or flexible connector shall be provided not more than 12 inches (305 mm) from the point of attachment to the supporting box or fitting.

**(4) Switches.** Switches that are a part of an assembled fixture or of an individual lampholder shall comply with Section 501-6(b)(1).

**(5) Starting Equipment.** Starting and control equipment for electric-discharge lamps shall comply with Section 501-7(b).

*Exception: A thermal protector potted into a thermally protected fluorescent lamp ballast if the lighting fixture is approved for locations of this Class and Division.*

#### **501-10. Utilization Equipment.**

**(a) Class I, Division 1.** In Class I, Division 1 locations, all utilization equipment shall be approved for Class I, Division 1 locations.

**(b) Class I, Division 2.** In Class I, Division 2 locations, all utilization equipment shall comply with the following:

**(1) Heaters.** Electrically heated utilization equipment shall conform with either a. or b. below.

a. The heater shall not exceed 80 percent of the ignition temperature in degrees Celsius of the gas or vapor involved on any surface which is exposed to the gas or vapor when continuously energized at the maximum rated ambient temperature. If a temperature controller is not provided, these conditions shall apply when the heater is operated at 120 percent of rated voltage.

*Exception: For motor-mounted anti-condensation space heaters see Section 501-8(b).*

b. The heater shall be approved for Class I, Division 1 locations.

**(2) Motors.** Motors of motor-driven utilization equipment shall comply with Section 501-8(b).

**(3) Switches, Circuit Breakers, and Fuses.** Switches, circuit breakers, and fuses shall comply with Section 501-6(b).

**501-11. Flexible Cords, Class I, Divisions 1 and 2.** A flexible cord shall be permitted only for connection between portable lighting equipment or other portable utilization equipment and the fixed portion of its supply circuit; and where used shall: (1) be of a type approved for extra-hard usage; (2) contain, in addition to the conductors of the circuit, a grounding conductor complying with Section 400-23; (3) be connected to terminals or to supply conductors in an approved manner; (4) be supported by clamps or by other suitable means in such a manner that there will be no tension on the terminal connections; and (5) be provided with suitable seals where the flexible cord enters boxes, fittings, or enclosures of the explosionproof type.

*Exception: As provided in Sections 501-3(b)(6) and 501-4(b).*

Electric submersible pumps with means for removal without entering the wet-pit shall be considered portable utilization equipment.

(FPN): See Section 501-13 for flexible cords exposed to liquids having a deleterious effect on the conductor insulation.

**501-12. Receptacles and Attachment Plugs, Class I, Divisions 1 and 2.** Receptacles and attachment plugs shall be of the type providing for connection to the grounding conductor of a flexible cord and shall be approved for Class I locations.

*Exception: As provided in Section 501-3(b)(6).*

**501-13. Conductor Insulation, Class I, Divisions 1 and 2.** Where condensed vapors or liquids may collect on, or come in contact with, the insulation on conductors, such insulation shall be of a type approved for use under such conditions; or the insulation shall be protected by a sheath of lead or by other approved means.

**501-14. Signaling, Alarm, Remote-Control, and Communication Systems.**

**(a) Class I, Division 1.** In Class I, Division 1 locations, all apparatus and equipment of signaling, alarm, remote-control, and communication systems, regardless of voltage, shall be approved for Class I, Division 1 locations, and all wiring shall comply with Sections 501-4(a) and 501-5(a) and (c).

**(b) Class I, Division 2.** In Class I, Division 2 locations, signaling, alarm, remote-control, and communication systems shall comply with the following:

**(1) Contacts.** Switches, circuit breakers, and make-and-break contacts of pushbuttons, relays, alarm bells, and horns shall have enclosures approved for Class I, Division 1 locations in accordance with Section 501-3(a).

*Exception: General-purpose enclosures shall be permitted if current interrupting contacts are:*

*a. Immersed in oil; or*

*b. Enclosed within a chamber hermetically sealed against the entrance of gases or vapors; or*

*c. In circuits that under normal conditions do not release sufficient energy to ignite a specific ignitable atmospheric mixture, i.e., are nonincendive.*

(2) **Resistors and Similar Equipment.** Resistors, resistance devices, thermionic tubes, rectifiers, and similar equipment shall comply with Section 501-3(b)(2).

(3) **Protectors.** Enclosures shall be provided for lightning protective devices and for fuses. Such enclosures shall be permitted to be of the general-purpose type.

(4) **Wiring and Sealing.** All wiring shall comply with Sections 501-4(b) and 501-5(b) and (c).

**501-15. Live Parts, Class I, Divisions 1 and 2.** There shall be no exposed live parts.

**501-16. Grounding, Class I, Divisions 1 and 2.** Wiring and equipment in Class I, Division 1 and 2 locations shall be grounded as specified in Article 250 and with the following additional requirements:

(a) **Bonding.** The locknut-bushing and double-locknut types of contacts shall not be depended upon for bonding purposes but bonding jumpers with proper fittings or other approved means of bonding shall be used. Such means of bonding shall apply to all intervening raceways, fittings, boxes, enclosures, etc. between Class I locations and the point of grounding for service equipment.

(b) **Types of Equipment Grounding Conductors.** Where flexible metal conduit or liquidtight flexible metal conduit is used as permitted in Section 501-4(b), and is to be relied upon to complete a sole equipment grounding path, it shall be installed with internal or external bonding jumpers in parallel with each conduit and complying with Section 250-79.

**501-17. Surge Protection, Class I, Divisions 1 and 2.** Surge arresters, including their installation and connection, shall comply with Article 280. In addition, surge arresters if installed in a Class I, Division 1 location shall be in suitable enclosures.

## ARTICLE 502 — CLASS II LOCATIONS

**502-1. General.** The general rules of this Code shall apply to the electric wiring and equipment in locations classified as Class II locations in Section 500-6.

*Exception: As modified by this article.*

“Dust-ignitionproof,” as used in this article, shall mean enclosed in a manner that will exclude ignitable amounts of dusts or amounts that might affect performance or rating and that, where installed and protected in accordance with this Code, will not permit arcs, sparks, or heat otherwise generated or liberated inside of the enclosure to cause ignition of exterior accumulations or atmospheric suspensions of a specified dust on or in the vicinity of the enclosure.

Equipment installed in Class II locations shall be able to function at full rating without developing surface temperatures high enough to cause excessive dehydration or gradual carbonization of any organic dust deposits that may occur.

(FPN): Dust that is carbonized or excessively dry is highly susceptible to spontaneous ignition.

Equipment and wiring of the type defined in Article 100 as explosionproof shall not be required and shall not be acceptable in Class II locations unless approved for such locations.

Where Class II, Groups E and F dusts having a resistivity less than  $10^5$  ohm-centimeter are present in hazardous quantities, there are only Division 1 locations.

#### 502-2. Transformers and Capacitors.

(a) **Class II, Division 1.** In Class II, Division 1 locations, transformers and capacitors shall comply with the following:

(1) **Containing Liquid that Will Burn.** Transformers and capacitors containing a liquid that will burn shall be installed only in approved vaults complying with Sections 450-41 through 450-48, and in addition: (1) doors or other openings communicating with the Division 1 location shall have self-closing fire doors on both sides of the wall, and the doors shall be carefully fitted and provided with suitable seals (such as weather stripping) to minimize the entrance of dust into the vault; (2) vent openings and ducts shall communicate only with the outside air; and (3) suitable pressure-relief openings communicating with the outside air shall be provided.

(2) **Not Containing Liquid that Will Burn.** Transformers and capacitors that do not contain a liquid that will burn shall: (1) be installed in vaults complying with Sections 450-41 through 450-48, or (2) be approved as a complete assembly, including terminal connections for Class II locations.

(3) **Metal Dusts.** No transformer or capacitor shall be installed in a location where dust from magnesium, aluminum, aluminum bronze powders, or other metals of similarly hazardous characteristics may be present.

(b) **Class II, Division 2.** In Class II, Division 2 locations, transformers and capacitors shall comply with the following:

(1) **Containing Liquid that Will Burn.** Transformers and capacitors containing a liquid that will burn shall be installed in vaults complying with Sections 450-41 through 450-48.

(2) **Containing Askarel.** Transformers containing askarel and rated in excess of 25 kVA shall: (1) be provided with pressure-relief vents; (2) be provided with a means for absorbing any gases generated by arcing inside the case, or the pressure-relief vents shall be connected to a chimney or flue that will carry such gases outside the building; and (3) have an air space of not less than 6 inches (152 mm) between the transformer cases and any adjacent combustible material.

(3) **Dry-type Transformers.** Dry-type transformers shall be installed in vaults or shall: (1) have their windings and terminal connections enclosed in tight metal housings without ventilating or other openings, and (2) operate at not over 600 volts, nominal.

502-4. **Wiring Methods.** Wiring methods shall comply with (a) and (b) below:

(a) **Class II, Division 1.** In Class II, Division 1 locations, threaded rigid metal conduit, threaded steel intermediate metal conduit or Type MI cable with termination fittings approved for the location shall be the wiring method.

employed. Type MI cable shall be installed and supported in a manner to avoid tensile stress at the termination fittings.

(1) **Fittings and Boxes.** Fittings and boxes shall be provided with threaded bosses for connection to conduit or cable terminations, shall have close-fitting covers, and shall have no openings (such as holes for attachment screws) through which dust might enter or through which sparks or burning material might escape. Fittings and boxes in which taps, joints, or terminal connections are made, or that are used in locations where dusts are of a combustible electrically conductive nature, shall be approved for Class II locations.

(2) **Flexible Connections.** Where necessary to employ flexible connections, dusttight flexible connectors, liquidtight flexible metal conduit with approved fittings, or flexible cord approved for extra-hard usage and provided with bushed fittings shall be used. Where flexible cords are used and electrically conducting dusts are encountered, they shall be provided with dusttight seals at both ends. An additional conductor for grounding shall be provided in the flexible cord unless other acceptable means of grounding is provided. Where flexible connections are subject to oil or other corrosive conditions, the insulation of the conductors shall be of a type approved for the condition or shall be protected by means of a suitable sheath.

(b) **Class II, Division 2.** In Class II, Division 2 locations, rigid metal conduit, intermediate metal conduit, electrical metallic tubing, dusttight wireways, or Type MI, MC, or SNM cable with approved termination fittings, or Type PLTC or TC cable installed in ventilated channel-type cable trays in a single layer with a space not less than the larger cable diameter between the two adjacent cables shall be the wiring method employed.

*Exception: Wiring, which under normal conditions cannot release sufficient energy to ignite a specific combustible dust mixture by opening, shorting or grounding, shall be permitted using any of the methods suitable for wiring in ordinary locations.*

(1) **Wireways, Fittings, and Boxes.** Wireways, fittings, and boxes in which taps, joints, or terminal connections are made shall be designed to minimize the entrance of dust, and: (1) shall be provided with telescoping or close-fitting covers or other effective means to prevent the escape of sparks or burning material, and (2) shall have no openings (such as holes for attachment screws) through which, after installation, sparks or burning material might escape or through which adjacent combustible material might be ignited.

(2) **Flexible Connections.** Where flexible connections are necessary, (a)(2) above shall apply.

**502-5. Sealing, Class II, Divisions 1 and 2.** Where a raceway provides communication between an enclosure that is required to be dust-ignition-proof and one that is not, suitable means shall be provided to prevent the entrance of dust into the dust-ignition-proof enclosure through the raceway. One of the following means shall be permitted: (1) a permanent and effective seal; (2) a horizontal raceway not less than 10 feet (3.05 m) long; or (3) a vertical raceway not less than 5 feet (1.52 m) long and extending downward from the dust-ignition-proof enclosure.

Where a raceway provides communication between an enclosure that is required to be dust-ignition-proof and an enclosure in an unclassified loca-

tion, seals will not be required.

Sealing fittings shall be accessible.

#### **502-6. Switches, Circuit Breakers, Motor Controllers, and Fuses.**

(a) **Class II, Division 1.** In Class II, Division 1 locations, switches, circuit breakers, motor controllers, and fuses shall comply with the following:

(1) **Type Required.** Switches, circuit breakers, motor controllers, and fuses, including pushbuttons, relays, and similar devices that are intended to interrupt current during normal operation or that are installed where combustible dusts of an electrically conductive nature may be present, shall be provided with dust-ignition-proof enclosures, which, together with the enclosed equipment in each case, shall be approved as a complete assembly for Class II locations.

(2) **Isolating Switches.** Disconnecting and isolating switches containing no fuses and not intended to interrupt current and not installed where dusts may be of an electrically conductive nature shall be provided with tight metal enclosures that shall be designed to minimize the entrance of dust, and that shall: (1) be equipped with telescoping or close-fitting covers or with other effective means to prevent the escape of sparks or burning material, and (2) have no openings (such as holes for attachment screws) through which, after installation, sparks or burning material might escape or through which exterior accumulations of dust or adjacent combustible material might be ignited.

(3) **Metal Dusts.** In locations where dust from magnesium, aluminum, aluminum bronze powders, or other metals of similarly hazardous characteristics may be present, fuses, switches, motor controllers, and circuit breakers shall have enclosures specifically approved for such locations.

(b) **Class II, Division 2.** In Class II, Division 2 locations, enclosures for fuses, switches, circuit breakers, and motor controllers, including pushbuttons, relays, and similar devices, shall be dusttight.

#### **502-7. Control Transformers and Resistors.**

(a) **Class II, Division 1.** In Class II, Division 1 locations, control transformers, solenoids, impedance coils, resistors, and any overcurrent devices or switching mechanisms associated with them shall have dust-ignition-proof enclosures approved for Class II locations. No control transformer, impedance coil, or resistor shall be installed in a location where dust from magnesium, aluminum, aluminum bronze powders, or other metals of similarly hazardous characteristics may be present unless provided with an enclosure approved for the specific location.

(b) **Class II, Division 2.** In Class II, Division 2 locations, transformers and resistors shall comply with the following:

(1) **Switching Mechanisms.** Switching mechanisms (including overcurrent devices) associated with control transformers, solenoids, impedance coils, and resistors shall be provided with dusttight enclosures.

(2) **Coils and Windings.** Where not located in the same enclosure with switching mechanisms, control transformers, solenoids, and impedance coils shall be provided with tight metal housings without ventilating openings.

(3) **Resistors.** Resistors and resistance devices shall have dust-ignition-proof enclosures approved for Class II locations.

*Exception: Where the maximum normal operating temperature of the resistor will not exceed 120°C (248°F), nonadjustable resistors or resistors that are part of an automatically timed starting sequence shall be permitted to have enclosures complying with (b)(2) above.*

#### **502-8. Motors and Generators.**

**(a) Class II, Division 1.** In Class II, Division 1 locations, motors, generators, and other rotating electrical machinery shall be:

(1) Approved for Class II, Division 1 locations, or

(2) Totally enclosed pipe-ventilated, meeting temperature limitations in Section 502-1.

**(b) Class II, Division 2.** In Class II, Division 2 locations, motors, generators, and other rotating electrical equipment shall be totally enclosed nonventilated, totally enclosed pipe ventilated, totally enclosed fan cooled or dust-ignition-proof for which maximum full-load external temperature shall be in accordance with Section 500-3(d) for normal operation when operating in free air (not dust blanketed) and shall have no external openings.

*Exception: If the authority having jurisdiction believes accumulations of nonconductive nonabrasive dust will be moderate, and if machines can be easily reached for routine cleaning and maintenance, the following shall be permitted to be installed:*

*a. Standard open-type machines without sliding contacts, centrifugal or other types of switching mechanism (including motor overcurrent, overloading and overtemperature devices), or integral resistance devices.*

*b. Standard open-type machines with such contacts, switching mechanisms, or resistance devices enclosed within dusttight housings without ventilating or other openings.*

*c. Self-cleaning textile motors of the squirrel-cage type.*

**502-9. Ventilating Piping.** Ventilating pipes for motors, generators, or other rotating electric machinery, or for enclosures for electric equipment, shall be of metal not lighter than No. 24 MSG, or of equally substantial noncombustible material, and shall comply with the following: (1) lead directly to a source of clean air outside of buildings; (2) be screened at the outer ends to prevent the entrance of small animals or birds; and (3) be protected against physical damage and against rusting or other corrosive influences.

Ventilating pipes shall also comply with (a) and (b) below.

**(a) Class II, Division 1.** In Class II, Division 1 locations, ventilating pipes, including their connections to motors or to the dust-ignition-proof enclosures for other equipment, shall be dusttight throughout their length. For metal pipes, seams and joints shall comply with one of the following: (1) be riveted and soldered; (2) be bolted and soldered; (3) be welded; or (4) be rendered dusttight by some other equally effective means.

**(b) Class II, Division 2.** In Class II, Division 2 locations, ventilating pipes and their connections shall be sufficiently tight to prevent the entrance of appreciable quantities of dust into the ventilated equipment or enclosure, and to prevent the escape of sparks, flame, or burning material that might ignite dust accumulations or combustible material in the vicinity. For metal pipes, lock seams and riveted or welded joints shall be permitted; and tight-fitting



slip joints shall be permitted where some flexibility is necessary, as at connections to motors.

#### 502-10. Utilization Equipment.

(a) **Class II, Division 1.** In Class II, Division 1 locations, all utilization equipment shall be approved for Class II locations. Where dust from magnesium, aluminum, aluminum bronze powders, or other metals of similarly hazardous characteristics may be present, such equipment shall be approved for the specific location.

(b) **Class II, Division 2.** In Class II, Division 2 locations, all utilization equipment shall comply with the following:

(1) **Heaters.** Electrically heated utilization equipment shall be approved for Class II locations.

*Exception: Metal-enclosed radiant heating panel equipment shall be dusttight and marked in accordance with Section 500-3(d).*

(2) **Motors.** Motors of motor-driven utilization equipment shall comply with Section 502-8(b).

(3) **Switches, Circuit-Breakers, and Fuses.** Enclosures for switches, circuit breakers, and fuses shall be dusttight.

(4) **Transformers, Impedance Coils, and Resistors.** Transformers, solenoids, impedance coils, and resistors shall comply with Section 502-7(b).

502-11. **Lighting Fixtures.** Lighting fixtures shall comply with (a) and (b) below.

(a) **Class II, Division 1.** In Class II, Division 1 locations, lighting fixtures for fixed and portable lighting shall comply with the following:

(1) **Approved Fixtures.** Each fixture shall be approved for Class II locations and shall be clearly marked to indicate the maximum wattage of the lamp for which it is approved. In locations where dust from magnesium, aluminum, aluminum bronze powders, or other metals of similarly hazardous characteristics may be present, fixtures for fixed or portable lighting and all auxiliary equipment shall be approved for the specific location.

(2) **Physical Damage.** Each fixture shall be protected against physical damage by a suitable guard or by location.

(3) **Pendant Fixtures.** Pendant fixtures shall be suspended by threaded rigid metal conduit stems, threaded steel intermediate metal conduit stems, by chains with approved fittings, or by other approved means. For rigid stems longer than 12 inches (305 mm), permanent and effective bracing against lateral displacement shall be provided at a level not more than 12 inches (305 mm) above the lower end of the stem, or flexibility in the form of a fitting or a flexible connector approved for the location shall be provided not more than 12 inches (305 mm) from the point of attachment to the supporting box or fitting. Threaded joints shall be provided with set-screws or other effective means to prevent loosening. Where wiring between an outlet box or fitting and a pendant fixture is not enclosed in conduit, flexible cord approved for hard usage shall be used, and suitable seals shall be provided where the cord enters the fixture and the outlet box or fitting. Flexible cord shall not serve as the supporting means for a fixture.

(4) **Supports.** Boxes, box assemblies, or fittings used for the support of lighting fixtures shall be approved for Class II locations.

**(b) Class II, Division 2:** In Class II, Division 2 locations, lighting fixtures shall comply with the following:

**(1) Portable Lighting Equipment.** Portable lighting equipment shall be approved for Class II locations. They shall be clearly marked to indicate the maximum wattage of lamps for which they are approved.

**(2) Fixed Lighting.** Lighting fixtures for fixed lighting, where not of a type approved for Class II locations, shall provide enclosures for lamps and lampholders that shall be designed to minimize the deposit of dust on lamps and to prevent the escape of sparks, burning material, or hot metal. Each fixture shall be clearly marked to indicate the maximum wattage of the lamp that shall be permitted without exceeding an exposed surface temperature in accordance with Section 500-3(d) under normal conditions of use.

**(3) Physical Damage.** Lighting fixtures for fixed lighting shall be protected from physical damage by suitable guards or by location.

**(4) Pendant Fixtures.** Pendant fixtures shall be suspended by threaded rigid metal conduit stems, threaded steel intermediate metal conduit stems, by chains with approved fittings, or by other approved means. For rigid stems longer than 12 inches (305 mm), permanent and effective bracing against lateral displacement shall be provided at a level not more than 12 inches (305 mm) above the lower end of the stem, or flexibility in the form of an approved fitting or a flexible connector shall be provided not more than 12 inches (305 mm) from the point of attachment to the supporting box or fitting. Where wiring between an outlet box or fitting and a pendant fixture is not enclosed in conduit, flexible cord approved for hard usage shall be used. Flexible cord shall not serve as the supporting means for a fixture.

**(5) Electric-Discharge Lamps:** Starting and control equipment for electric-discharge lamps shall comply with the requirements of Section 502-7 (b).

**502-12. Flexible Cords, Class II, Divisions 1 and 2.** Flexible cords used in Class II locations shall comply with the following: (1) be of a type approved for extra-hard usage; (2) contain, in addition to the conductors of the circuit, a grounding conductor complying with Section 400-23; (3) be connected to terminals or to supply conductors in an approved manner; (4) be supported by clamps or by other suitable means in such a manner that there will be no tension on the terminal connections; and (5) be provided with suitable seals to prevent the entrance of dust where the flexible cord enters boxes or fittings that are required to be dust-ignition-proof.

**502-13. Receptacles and Attachment Plugs:**

**(a) Class II, Division 1.** In Class II, Division 1 locations, receptacles and attachment plugs shall be of the type providing for connection to the grounding conductor of the flexible cord and shall be approved for Class II locations.

**(b) Class II, Division 2:** In Class II, Division 2 locations, receptacles and attachment plugs shall be of the type providing for connection to the grounding conductor of the flexible cord and shall be so designed that connection to the supply circuit cannot be made or broken while live parts are exposed.

**502-14. Signaling, Alarm, Remote-Control, and Communication Systems, Meters, Instruments, and Relays.**

(FPN): See Article 800 for rules governing the installation of communication circuits.

(a) **Class II, Division 1.** In Class II, Division 1 locations, signaling, alarm, remote-control, and communication systems; and meters, instruments, and relays shall comply with the following:

(1) **Wiring Methods.** Where accidental damage or breakdown of insulation might cause arcs, sparks, or high temperatures, the wiring method shall be rigid metal conduit, intermediate metal conduit, electrical metallic tubing, or Type MI cable with approved termination fittings. For rigid conduit, intermediate metal conduit, or electrical metallic tubing, the number of conductors shall be limited only by the requirement that the cross-sectional area of all conductors shall not exceed 40 percent of the area of the raceway. Where limited flexibility is desirable or where exposure to physical damage is not severe, flexible cord approved for extra-hard usage shall be permitted.

(2) **Contacts.** Switches, circuit breakers, relays, contactors, fuses and current-breaking contacts for bells, horns, howlers, sirens, and other devices in which sparks or arcs may be produced shall be provided with enclosures approved for a Class II location.

*Exception: Where current-breaking contacts are immersed in oil, or where the interruption of current occurs within a chamber sealed against the entrance of dust, enclosures shall be permitted to be of the general-purpose type.*

(3) **Resistors and Similar Equipment.** Resistors, transformers, choke coils, rectifiers, thermionic tubes, and other heat-generating equipment shall be provided with enclosures approved for Class II locations.

*Exception: Where resistors or similar equipment are immersed in oil, or enclosed in a chamber sealed against the entrance of dust, enclosures shall be permitted to be of the general-purpose type.*

(4) **Rotating Machinery.** Motors, generators, and other rotating electric machinery shall comply with Section 502-8(a).

(5) **Combustible Electrically Conductive Dusts.** Where dusts are of a combustible electrically conductive nature, all wiring and equipment shall be approved for Class II locations.

(6) **Metal Dusts.** Where dust from magnesium, aluminum, aluminum bronze powders, or other metals of similarly hazardous characteristics may be present; all apparatus and equipment shall be approved for the specific conditions.

(b) **Class II, Division 2.** In Class II, Division 2 locations, signaling, alarm, remote-control, and communication systems; and meters, instruments, and relays shall comply with the following:

(1) **Contacts.** Enclosures shall comply with (a)(2) above; or contacts shall have tight metal enclosures designed to minimize the entrance of dust, and shall have telescoping or tight-fitting covers and no openings through which, after installation, sparks or burning material might escape.

*Exception: In circuits that under normal conditions do not release sufficient energy to ignite a dust layer, enclosures shall be permitted to be of the general-purpose type.*

(2) **Transformers and Similar Equipment.** The windings and terminal connections of transformers, choke coils, and similar equipment shall be provided with tight metal enclosures without ventilating openings.

(3) **Resistors and Similar Equipment.** Resistors, resistance devices, thermionic tubes, rectifiers, and similar equipment shall comply with (a)(3) above.

*Exception: Enclosures for thermionic tubes, nonadjustable resistors, or rectifiers for which maximum operating temperature will not exceed 120°C (248°F) shall be permitted to be of the general-purpose type.*

(4) **Rotating Machinery.** Motors, generators, and other rotating electric machinery shall comply with Section 502-8(b).

(5) **Wiring Methods.** The wiring method shall comply with Section 502-4(b).

**502-15. Live Parts, Class II, Divisions 1 and 2.** Live parts shall not be exposed.

**502-16. Grounding, Class II, Divisions 1 and 2.** Wiring and equipment in Class II, Division 1 and 2 locations shall be grounded as specified in Article 250 and with the following additional requirements:

(a) **Bonding.** The locknut-bushing and double-locknut types of contact shall not be depended upon for bonding purposes but bonding jumpers with proper fittings or other approved means of bonding shall be used. Such means of bonding shall apply to all intervening raceways, fittings, boxes, enclosures, etc. between Class II locations and the point of grounding for service equipment.

(b) **Types of Equipment Grounding Conductors:** Where flexible conduit is used as permitted in Section 502-4 it shall be installed with internal or external bonding jumpers in parallel with each conduit and complying with Section 250-79.

*Exception: In Class II, Division 2 areas where approved liquidtight flexible metal conduit 6 feet (1.83 m) or less in length and fittings are used and overcurrent protection in the circuit is limited to 10 amperes or less and is not a power utilization load, the additional ground jumper shall be permitted to be deleted.*

**502-17. Surge Protection, Class II, Divisions 1 and 2.** Surge arresters, including their installation and connection shall comply with Article 280. In addition, surge arresters if installed in a Class II, Division 1 location shall be in suitable enclosures.

Surge-protective capacitors shall be of a type designed for specific duty.

## ARTICLE 503 — CLASS III LOCATIONS

**503-1. General.** The general rules of this Code shall apply to electric wiring and equipment in locations classified as Class III locations in Section 500-7.

*Exception: As modified by this article.*

Equipment installed in Class III locations shall be able to function at full rating without developing surface temperatures high enough to cause excessive dehydration or gradual carbonization of accumulated fibers or flyings. Organic material that is carbonized or excessively dry is highly susceptible to spontaneous ignition. The maximum surface temperatures under operating conditions shall not exceed 165°C (329°F) for equipment that is not subject to overloading, and 120°C (248°F) for equipment (such as motors or power transformers) that may be overloaded.

(FPN): For electric trucks, see Powered Industrial Trucks Including Type Designations, Areas of Use, Maintenance and Operation, NFPA 505-1982 (ANSI).

**503-2. Transformers and Capacitors, Class III, Divisions 1 and 2.** Transformers and capacitors shall comply with Section 502-2(b).

**503-3. Wiring Methods.** Wiring methods shall comply with (a) and (b) below.

(a) **Class III, Division 1.** In Class III, Division 1 locations, the wiring method shall be rigid metal conduit, rigid nonmetallic conduit, intermediate metal conduit, electrical metallic tubing, dusttight wireways, or Type MI, MC, or SNM cable with approved termination fittings.

(1) **Boxes and Fittings.** All boxes and fittings shall be dusttight.

(2) **Flexible Connections.** Where necessary to employ flexible connections, dusttight flexible connectors, liquidtight flexible metal conduit with approved fittings, or flexible cord approved for extra-hard usage and provided with bushed fittings shall be used. An additional conductor for equipment grounding shall be provided in the flexible cord unless other approved means of equipment grounding is provided.

(b) **Class III, Division 2.** In Class III, Division 2 locations, the wiring method shall comply with (a) above.

*Exception: In sections, compartments, or areas used solely for storage and containing no machinery, open wiring on insulators shall be permitted where installed in accordance with Article 320, but only on condition that protection as required by Section 320-14 be provided where conductors are not run in roof spaces and are well out of reach of sources of physical damage.*

**503-4. Switches, Circuit Breakers, Motor Controllers, and Fuses, Class III, Divisions 1 and 2.** Switches, circuit breakers, motor controllers, and fuses, including pushbuttons, relays, and similar devices, shall be provided with dusttight enclosures.

**503-5. Control Transformers and Resistors, Class III, Divisions 1 and 2.** Transformers, impedance coils, and resistors used as or in conjunction with control equipment for motors, generators, and appliances shall be provided with dusttight enclosures complying with the temperature limitations in Section 503-1..

**503-6. Motors and Generators, Class III, Divisions 1 and 2.** In Class III, Division 1 and 2 locations, motors, generators, and other rotating machinery shall be totally enclosed nonventilated, totally enclosed pipe-ventilated, or totally enclosed fan-cooled.

*Exception: In locations where, in the judgment of the authority having jurisdiction, only moderate accumulations of lint or flyings will be likely to collect on, in, or in the vicinity of a rotating electric machine, and where such machine is readily accessible for routine cleaning and maintenance, one of the following shall be permitted:*

- a. Self-cleaning textile motors of the squirrel-cage types;*
- b. Standard open-type machines without sliding contacts, centrifugal or other types of switching mechanism, including motor overload devices; or*
- c. Standard open-type machines having such contacts, switching mechanisms, or resistance devices enclosed within tight housings without ventilating or other openings.*

**503-7. Ventilating Piping, Class III, Divisions 1 and 2.** Ventilating pipes for motors, generators, or other rotating electric machinery, or for enclosures for electric equipment shall be of metal not lighter than No. 24 MSG, or of equally substantial noncombustible material, and shall comply with the following: (1) lead directly to a source of clean air outside of buildings; (2) be screened at the outer ends to prevent the entrance of small animals or birds; and (3) be protected against physical damage and against rusting or other corrosive influences.

Ventilating pipes shall be sufficiently tight, including their connections, to prevent the entrance of appreciable quantities of fibers or flyings into the ventilated equipment or enclosure and to prevent the escape of sparks, flame, or burning material that might ignite accumulations of fibers or flyings or combustible material in the vicinity. For metal pipes, lock seams and riveted or welded joints shall be permitted; and tight-fitting slip joints shall be permitted where some flexibility is necessary, as at connections to motors.

**503-8. Utilization Equipment, Class III, Divisions 1 and 2.**

(a) **Heaters.** Electrically heated utilization equipment shall be approved for Class III locations.

(b) **Motors.** Motors of motor-driven utilization equipment shall comply with Section 503-6.

(c) **Switches, Circuit Breakers, Motor Controllers, and Fuses.** Switches, circuit breakers, motor controllers, and fuses shall comply with Section 503-4.

**503-9. Lighting Fixtures, Class III, Divisions 1 and 2.**

(a) **Fixed Lighting.** Lighting fixtures for fixed lighting shall provide enclosures for lamps and lampholders that are designed to minimize entrance of fibers and flyings and to prevent the escape of sparks, burning material, or hot metal. Each fixture shall be clearly marked to show the maximum wattage of the lamps that shall be permitted without exceeding an exposed surface temperature of 165°C (329°F) under normal conditions of use.

(b) **Physical Damage.** A fixture that may be exposed to physical damage shall be protected by a suitable guard.

(c) **Pendant Fixtures.** Pendant fixtures shall be suspended by stems of threaded rigid metal conduit, threaded intermediate metal conduit, threaded metal tubing of equivalent thickness, or by chains with approved fittings. For stems longer than 12 inches (305 mm), permanent and effective bracing against lateral displacement shall be provided at a level not more than

12 inches (305 mm) above the lower end of the stem, or flexibility in the form of an approved fitting or a flexible connector shall be provided not more than 12 inches (305 mm) from the point of attachment to the supporting box or fitting.

(d) **Portable Lighting Equipment.** Portable lighting equipment shall be equipped with handles and protected with substantial guards. Lampholders shall be of the unswitched type with no provision for receiving attachment plugs. There shall be no exposed current-carrying metal parts and all exposed noncurrent-carrying metal parts shall be grounded. In all other respects, portable lighting equipment shall comply with (a) above.

**503-10. Flexible Cords, Class III, Divisions 1 and 2.** Flexible cords shall comply with the following: (1) be of a type approved for extra-hard usage; (2) contain, in addition to the conductors of the circuit, a grounding conductor complying with Section 400-23; (3) be connected to terminals or to supply conductors in an approved manner; (4) be supported by clamps or other suitable means in such a manner that there will be no tension on the terminal connections; and (5) be provided with suitable means to prevent the entrance of fibers or flyings where the cord enters boxes or fittings.

**503-11. Receptacles and Attachment Plugs, Class III, Divisions 1 and 2.** Receptacles and attachment plugs shall be of the grounding type and shall be so designed to minimize the accumulation or the entry of fibers or flyings, and shall prevent the escape of sparks or molten particles.

*Exception: In locations where, in the judgment of the authority having jurisdiction, only moderate accumulations of lint or flyings will be likely to collect in the vicinity of a receptacle, and where such receptacle is readily accessible for routine cleaning, general-purpose grounding-type receptacles mounted so as to minimize the entry of fibers or flyings shall be permitted.*

**503-12. Signaling, Alarm, Remote-Control, and Local Loudspeaker Intercommunication Systems, Class III, Divisions 1 and 2.** Signaling, alarm, remote-control, and local loudspeaker intercommunication systems shall comply with the requirements of Article 503 regarding wiring methods, switches, transformers, resistors, motors, lighting fixtures, and related components.

**503-13. Electric Cranes, Hoists, and Similar Equipment, Class III, Divisions 1 and 2.** Where installed for operation over combustible fibers or accumulations of flyings, traveling cranes and hoists for material handling, traveling cleaners for textile machinery, and similar equipment shall comply with (a) through (d) below.

(a) **Power Supply.** Power supply to contact conductors shall be isolated from all other systems and shall be equipped with an acceptable ground detector that will give an alarm and automatically de-energize the contact conductors in case of a fault to ground or will give a visual and audible alarm as long as power is supplied to the contact conductors and the ground fault remains.

(b) **Contact Conductors.** Contact conductors shall be so located or guarded as to be inaccessible to other than authorized persons and shall be protected against accidental contact with foreign objects.

(c) **Current Collectors.** Current collectors shall be so arranged or guarded as to confine normal sparking and prevent escape of sparks or hot particles. To reduce sparking, two or more separate surfaces of contact shall be

provided for each contact conductor. Reliable means shall be provided to keep contact conductors and current collectors free of accumulations of lint or flyings.

**(d) Control Equipment.** Control equipment shall comply with Sections 503-4 and 503-5.

**503-14. Storage-Battery Charging Equipment, Class III, Divisions 1 and 2.** Storage-battery charging equipment shall be located in separate rooms built or lined with substantial noncombustible materials so constructed as to adequately exclude flyings or lint and shall be well ventilated.

**503-15. Live Parts, Class III, Divisions 1 and 2.** Live parts shall not be exposed.

*Exception: As provided in Section 503-13.*

**503-16. Grounding, Class III, Divisions 1 and 2.** Wiring and equipment in Class III, Divisions 1 and 2 shall be grounded as specified in Article 250 and with the following additional requirements:

**(a) Bonding.** The locknut-bushing and double-locknut types of contacts shall not be depended upon for bonding purposes but bonding jumpers with proper fittings or other approved means of bonding shall be used. Such means of bonding shall apply to all intervening raceways, fittings, boxes, enclosures, etc. between Class III locations and the point of grounding for service equipment.

**(b) Types of Equipment Grounding Conductors.** Where flexible conduit is used as permitted in Section 503-3, it shall be installed with internal or external bonding jumpers in parallel with each conduit and complying with Section 250-79.

## ARTICLE 510 — HAZARDOUS (CLASSIFIED) LOCATIONS — SPECIFIC

**510-1. Scope.** Articles 511 through 517 cover occupancies or parts of occupancies that are or may be hazardous because of atmospheric concentrations of flammable liquids, gases, or vapors, or because of deposits or accumulations of materials that may be readily ignitable.

**510-2. General.** The general rules of this Code shall apply to electric wiring and equipment in occupancies within the scope of Articles 511 through 517, except as such rules are modified in those articles. Where unusual conditions exist in a specific occupancy, the authority having jurisdiction shall judge with respect to the application of specific rules.

## ARTICLE 511 — COMMERCIAL GARAGES, REPAIR AND STORAGE

**511-1. Scope.** These occupancies shall include locations used for service and repair operations in connection with self-propelled vehicles (including



passenger automobiles, buses, trucks, tractors, etc.) in which volatile flammable liquids are used for fuel or power.

**511-2. Locations.** Areas in which flammable fuel is transferred to vehicle fuel tanks shall conform to Article 514. Parking garages used for parking or storage and where no repair work is done except exchange of parts and routine maintenance requiring no use of electrical equipment, open flame, welding, or the use of volatile flammable liquids are not classified, but they shall be adequately ventilated to carry off the exhaust fumes of the engines.

(FPN): For further information, see Parking Structures, NFPA 88A-1985, and Repair Garages, NFPA 88B-1985.

**511-3. Class I Locations.** Classification under Article 500.

**(a) Up to a Level of 18 Inches (457 mm) Above the Floor.** For each floor the entire area up to a level of 18 inches (457 mm) above the floor shall be considered to be a Class I, Division 2 location except where the enforcing agency determines that there is mechanical ventilation providing a minimum of four air changes per hour.

**(b) Any Pit or Depression Below Floor Level.** Any pit or depression below floor level shall be considered to be a Class I, Division 1 location which shall extend up to said floor level, except that any pit or depression in which six air changes per hour are exhausted at the floor level of the pit shall be permitted to be judged by the enforcing agency to be a Class I, Division 2 location.

**(c) Areas Adjacent to Defined Locations with Positive Pressure Ventilation.** Areas adjacent to defined locations in which flammable vapors are not likely to be released such as stock rooms, switchboard rooms, and other similar locations shall not be classified when mechanically ventilated at a rate of four or more air changes per hour or when effectively cut off by walls or partitions.

**(d) Adjacent Areas by Special Permission.** Adjacent areas which by reason of ventilation, air pressure differentials, or physical spacing are such that, in the opinion of the authority enforcing this Code, no ignition hazard exists shall be classified as nonhazardous.

**(e) Fuel Dispensing Units.** When fuel dispensing units (other than liquid petroleum gas which is prohibited) are located within buildings, the requirements of Article 514 shall govern.

When mechanical ventilation is provided in the dispensing area, the controls shall be interlocked so that the dispenser cannot operate without ventilation as prescribed in Section 500-5(b).

**(f) Portable Lighting Equipment.** Portable lighting equipment shall be equipped with handle, lampholder, hook and substantial guard attached to the lampholder or handle. All exterior surfaces which might come in contact with battery terminals, wiring terminals, or other objects shall be of nonconducting material or shall be effectively protected with insulation. Lampholders shall be of unswitched type and shall not provide means for plug-in of attachment plugs. Outer shell shall be of molded composition or other suitable material. Unless the lamp and its cord are supported or arranged in such a manner that they cannot be used in the locations classified in Section 511-3 they shall be of a type approved for Class I, Division 1 locations.

**511-4. Wiring and Equipment in Class I Locations.** Within Class I locations as defined in Section 511-3, wiring and equipment shall conform to applicable provisions of Article 501. Raceways embedded in a masonry wall or buried beneath a floor shall be considered to be within the Class I location above the floor if any connections or extensions lead into or through such areas.

**511-5. Sealing.** Approved seals conforming to the requirements of Section 501-5 shall be provided, and Section 501-5(b)(2) shall apply to horizontal as well as vertical boundaries of the defined Class I locations.

**511-6. Wiring in Spaces Above Class I Locations.**

(a) **Fixed Wiring Above Class I Locations.** All fixed wiring above Class I locations shall be in metallic raceways, rigid nonmetallic conduit, electrical nonmetallic tubing, or shall be Type MI, TC, SNM, or Type MC cable. Cellular metal floor raceways or cellular concrete floor raceways shall be permitted to be used only for supplying ceiling outlets or extensions to the area below the floor, but such raceways shall have no connections leading into or through any Class I location above the floor.

(b) **Pendants.** For pendants, flexible cord suitable for the type of service and approved for hard usage shall be used.

(c) **Grounded Conductor.** When a circuit which supplies portables or pendants includes a grounded conductor as provided in Article 200, receptacles, attachment plugs, connectors, and similar devices shall be of polarized type, and the grounded conductor of the flexible cord shall be connected to the screw shell of any lampholder or to the grounded terminal of any utilization equipment supplied.

(d) **Attachment Plug Receptacles.** Attachment plug receptacles in fixed position shall be located above the level of any defined Class I location, or be approved for the location.

**511-7. Equipment Above Class I Locations.**

(a) **Arcing Equipment.** Equipment that is less than 12 feet (3.66 m) above the floor level and that may produce arcs, sparks, or particles of hot metal, such as cutouts, switches, charging panels, generators, motors, or other equipment (excluding receptacles, lamps and lampholders) having make-and-break or sliding contacts, shall be of the totally enclosed type or so constructed as to prevent escape of sparks or hot metal particles.

(b) **Fixed Lighting.** Lamps and lampholders for fixed lighting that is located over lanes through which vehicles are commonly driven or that may otherwise be exposed to physical damage shall be located not less than 12 feet (3.66 m) above floor level, unless of the totally enclosed type or so constructed as to prevent escape of sparks or hot metal particles.

**511-8. Battery Charging Equipment.** Battery chargers and their control equipment, and batteries being charged shall not be located within locations classified in Section 511-3.

**511-9. Electric Vehicle Charging.**

(a) **Connections.** Flexible cords and connectors used for charging shall be suitable for the type of service and approved for extra-hard usage. Their ampacity shall be adequate for the charging current.

(b) **Connector Design and Location.** Connectors shall be so designed and installed that they will disconnect readily at any position of the charging cable, and live parts shall be guarded from accidental contact. No connector shall be located within a Class I location as defined in Section 511-3.

(c) **Plug Connections to Vehicles.** Where plugs are provided for direct connection to vehicles, the point of connection shall not be within a Class I location as defined in Section 511-3, and where the cord is suspended from overhead, it shall be so arranged that the lowest point of sag is at least 6 inches (152 mm) above the floor. Where the vehicle is equipped with an approved plug that will disconnect readily, and where an automatic arrangement is provided to pull both cord and plug beyond the range of physical damage, no additional connector shall be required in the cable or at the outlet.

**511-10. Ground-Fault Circuit-Interrupter Protection for Personnel.** All 125-volt single-phase, 15- and 20-ampere receptacles, where electrical automotive diagnostic equipment, electrical hand tools and portable lighting devices are used, shall have ground-fault circuit-interrupter protection for personnel.

## ARTICLE 513 — AIRCRAFT HANGARS

**513-1. Definition.** An aircraft hangar is a location used for storage or servicing of aircraft in which gasoline, jet fuels, or other volatile flammable liquids or flammable gases are used. It shall not include locations used exclusively for aircraft that have never contained such liquids or gases, or that have been drained and properly purged.

### 513-2. Classification of Locations.

(a) **Below Floor Level.** Any pit or depression below the level of the hangar floor shall be classified as a Class I, Division 1 location that shall extend up to said floor level.

(b) **Areas Not Cut Off or Ventilated.** The entire area of the hangar, including any adjacent and communicating areas not suitably cut off from the hangar, shall be classified as a Class I, Division 2 location up to a level 18 inches (457 mm) above the floor.

(c) **Vicinity of Aircraft.** The area within 5 feet (1.52 m) horizontally from aircraft power plants or aircraft fuel tanks shall be classified as a Class I, Division 2 location that shall extend upward from the floor to a level 5 feet (1.52 m) above the upper surface of wings and of engine enclosures.

(d) **Areas Suitably Cut Off and Ventilated.** Adjacent areas in which flammable liquids or vapors are not likely to be released, such as stock rooms, electrical control rooms, and other similar locations, shall not be classified where adequately ventilated and where effectively cut off from the hangar itself by walls or partitions.

**513-3. Wiring and Equipment in Class I Locations.** All wiring and equipment that is or may be installed or operated within any of the Class I locations defined in Section 513-2 shall comply with the applicable provisions of Article 501. All wiring installed in or under the hangar floor shall comply with the requirements for Class I, Division 1 locations. Where such wiring is located

in vaults, pits, or ducts, adequate drainage shall be provided; and the wiring shall not be placed within the same compartment with any service other than piped compressed air.

Attachment plugs and receptacles in Class I locations shall be approved for Class I locations or shall be so designed that they cannot be energized while the connections are being made or broken.

#### **513-4. Wiring Not Within Class I Locations.**

(a) **Fixed Wiring.** All fixed wiring in a hangar, but not within a Class I location as defined in Section 513-2, shall be installed in metallic raceways or shall be Type MI, TC, SNM or Type MC cable.

*Exception: Wiring in nonhazardous locations as defined in Section 513-2(d) shall be of a type recognized in Chapter 3.*

(b) **Pendants.** For pendants, flexible cord suitable for the type of service and approved for hard usage shall be used. Each such cord shall include a separate grounding conductor.

(c) **Portable Equipment.** For portable utilization equipment and lamps, flexible cord suitable for the type of service and approved for extra-hard usage shall be used. Each such cord shall include a separate grounding conductor.

(d) **Grounded and Grounding Conductors.** Where a circuit supplies portables or pendants and includes a grounded conductor as provided in Article 200, receptacles, attachment plugs, connectors, and similar devices shall be of the polarized type, and the grounded conductor of the flexible cord shall be connected to the screw shell of any lampholder or to the grounded terminal of any utilization equipment supplied. Approved means shall be provided for maintaining continuity of the grounding conductor between the fixed raceway system and the noncurrent-carrying metal portions of pendant fixtures, portable lamps, and portable utilization equipment.

#### **513-5. Equipment Not Within Class I Locations.**

(a) **Arcing Equipment.** In locations other than those described in Section 513-2, equipment that is less than 10 feet (3.05 m) above wings and engine enclosures of aircraft and that may produce arcs, sparks, or particles of hot metal, such as lamps and lampholders for fixed lighting, cutouts, switches, receptacles, charging panels, generators, motors, or other equipment having make-and-break or sliding contacts, shall be of the totally enclosed type or so constructed as to prevent escape of sparks or hot metal particles.

*Exception: Equipment in areas described in Section 513-2(d) shall be permitted to be of the general-purpose type.*

(b) **Lampholders.** Lampholders of metal-shell, fiber-lined types shall not be used for fixed incandescent lighting.

(c) **Portable Lighting Equipment.** Portable lighting equipment that are used within a hangar shall be approved for the location in which they are used.

(d) **Portable Equipment.** Portable utilization equipment that is or may be used within a hangar shall be of a type suitable for use in Class I, Division 2 locations.

**513-6. Stanchions, Rostrums, and Docks.**

(a) **In Class I Location.** Electric wiring, outlets, and equipment (including lamps) on or attached to stanchions, rostrums, or docks that are located or likely to be located in a Class I location as defined in Section 513-2(c) shall comply with the requirements for Class I, Division 2 locations.

(b) **Not in Class I Location.** Where stanchions, rostrums, or docks are not located or likely to be located in a Class I location as defined in Section 513-2(c), wiring and equipment shall comply with Sections 513-4 and 513-5, except that such wiring and equipment not more than 18 inches (457 mm) above the floor in any position shall comply with (a) above. Receptacles and attachment plugs shall be of a locking type that will not readily disconnect.

(c) **Mobile Type.** Mobile stanchions with electric equipment complying with (b) above shall carry at least one permanently affixed warning sign to read: "WARNING — KEEP 5 FEET CLEAR OF AIRCRAFT ENGINES AND FUEL TANK AREAS."

**513-7. Sealing.** Approved seals shall be provided in accordance with Section 501-5. Sealing requirements specified in Section 501-5(a)(4) and (b)(2) shall apply to horizontal as well as to vertical boundaries of the defined Class I locations. Raceways embedded in a masonry floor or buried beneath a floor shall be considered to be within the Class I location above the floor where any connections or extensions lead into or through such location.

**513-8. Aircraft Electrical Systems.** Aircraft electrical systems shall be de-energized when the aircraft is stored in a hangar, and, whenever possible, while the aircraft is undergoing maintenance.

**513-9. Aircraft Battery — Charging and Equipment.** Aircraft batteries shall not be charged when installed in an aircraft located inside or partially inside a hangar.

Battery chargers and their control equipment shall not be located or operated within any of the Class I locations defined in Section 513-2, and shall preferably be located in a separate building or in an area such as defined in Section 513-2(d). Mobile chargers shall carry at least one permanently affixed warning sign to read: "WARNING — KEEP 5 FEET CLEAR OF AIRCRAFT ENGINES AND FUEL TANK AREAS." Tables, racks, trays, and wiring shall not be located within a Class I location, and, in addition, shall comply with Article 480.

**513-10. External Power Sources for Energizing Aircraft.**

(a) **Not Less than 18 Inches (457 mm) Above Floor.** Aircraft energizers shall be so designed and mounted that all electric equipment and fixed wiring will be at least 18 inches (457 mm) above floor level and shall not be operated in a Class I location as defined in Section 513-2(c).

(b) **Marking for Mobile Units.** Mobile energizers shall carry at least one permanently affixed warning sign to read: "WARNING — KEEP 5 FEET CLEAR OF AIRCRAFT ENGINES AND FUEL TANK AREAS."

(c) **Cords.** Flexible cords for aircraft energizers and ground support equipment shall be approved for the type of service and extra-hard usage and shall include an equipment grounding conductor.

**513-11. Mobile Servicing Equipment with Electric Components.**

(a) **General.** Mobile servicing equipment (such as vacuum cleaners, air compressors, air movers, etc.) having electric wiring and equipment not suitable for Class I, Division 2 locations shall be so designed and mounted that all such fixed wiring and equipment will be at least 18 inches (457 mm) above the floor. Such mobile equipment shall not be operated within the Class I location defined in Section 513-2(c) and shall carry at least one permanently affixed warning sign to read: "WARNING — KEEP 5 FEET CLEAR OF AIRCRAFT ENGINES AND FUEL TANK AREAS."

(b) **Cords and Connectors.** Flexible cords for mobile equipment shall be suitable for the type of service and approved for extra-hard usage, and shall include an equipment grounding conductor. Attachment plugs and receptacles shall be approved for the location in which they are installed, and shall provide for connection of the equipment grounding conductor to the raceway system.

(c) **Restricted Use.** Equipment that is not identified as suitable for Class I, Division 2 locations shall not be operated in locations where maintenance operations likely to release flammable liquids or vapors are in progress.

**513-12. Grounding.** All metal raceways and all noncurrent-carrying metal portions of fixed or portable equipment, regardless of voltage, shall be grounded as provided in Article 250.

## ARTICLE 514 — GASOLINE DISPENSING AND SERVICE STATIONS

**514-1. Definition.** A gasoline dispensing and service station is a location where gasoline or other volatile flammable liquids or liquefied flammable gases are transferred to the fuel tanks (including auxiliary fuel tanks) of self-propelled vehicles.

Other areas used as lubricatoriums, service rooms, repair rooms, offices, salesrooms, compressor rooms, and similar locations shall comply with Articles 510 and 511 with respect to electric wiring and equipment.

Where the authority having jurisdiction can satisfactorily determine that flammable liquids having a flash point below 38(100) such as gasoline, will not be handled, such authority may classify that location as nonhazardous.

(FPN): For further information regarding safeguards for gasoline dispensing and service stations, see Automotive and Marine Service Station Code, NFPA 30A-1984.

**514-2.\* Class I Locations.** Table 514-2 shall be applied where Class I liquids are stored, handled, or dispensed and shall be used to delineate and classify service stations. A Class I location shall not extend beyond an unpierced wall, roof, or other solid partition.

**514-3: Wiring and Equipment Within Class I Locations.** All electric equipment and wiring within Class I locations defined in Section 514-2 shall comply with the applicable provisions of Article 501.

*Exception: As permitted in Section 514-8.*

(FPN): For special requirements for conductor insulation, see Section 501-13.

Table 514-2\*. Class I Locations — Service Stations

Location	Class I, Group D Division	Extent of Class I Location
<b>Underground Tank Fill Opening</b>	1	Any pit, box, or space below grade level, any part of which is within the Division 1 or 2 location.
	2	Up to 18 inches above grade level within a horizontal radius of 10 feet from a loose fill connection and within a horizontal radius of 5 feet from a tight fill connection.
<b>Vent — Discharging Upward</b>	1	Within 3 feet of open end of vent, extending in all directions.
	2	Space between 3 feet and 5 feet of open end of vent, extending in all directions.
<b>Dispensing Units (except overhead type)</b>		
<b>Pits</b>	1	Any pit, box, or space below grade level, any part of which is within the Division 1 or 2 location.
<b>Dispenser</b>	1	The space within a dispenser enclosure up to 4 feet vertically above the base except that space defined as Division 2. Any space within a nozzle boot.
	2	Spaces within a dispenser enclosure above the Division 1 location. Spaces within a dispenser enclosure isolated from Division 1 by a solid partition or a solid nozzle boot but not completely surrounded by Division 1 location. Within 18 inches horizontally in all directions from the Division 1 location located within the dispenser enclosure. Within 18 inches horizontally in all directions from the opening of a nozzle boot not isolated by a vapor-tight partition, except that the classified location need not be extended around a 90 degree or greater corner.
<b>Outdoor</b>	2	Up to 18 inches above grade level within 20 feet horizontally of any edge of enclosure.
<b>Indoor with Mechanical Ventilation</b>	2	Up to 18 inches above grade or floor level within 20 feet horizontally of any edge of enclosure.
<b>with Gravity Ventilation</b>	2	Up to 18 inches above grade or floor level within 25 feet horizontally of any edge of enclosure.

Table 514-2 (Continued)

Location	Class I, Group D Division	Extent of Class I Location
Dispensing Units, Overhead Type	1	Within the dispenser enclosure and 18 inches in all directions from the enclosure where not suitably cut off by ceiling or wall. All electrical equipment integral with the dispensing hose or nozzle.
	2	A space extending 2 feet horizontally in all directions beyond the Division 1 location and extending to grade below this classified location.
	2	Up to 18 inches above grade level within 20 feet horizontally measured from a point vertically below the edge of any dispenser enclosure.
Remote Pump — Outdoor	1	Any pit, box, or space below grade level if any part is within a horizontal distance of 10 feet from any edge of pump.
	2	Within 3 feet of any edge of pump, extending in all directions. Also up to 18 inches above grade level within 10 feet horizontally from any edge of pump.
Remote Pump — Indoor	1	Entire space within any pit.
	2	Within 5 feet of any edge of pump, extending in all directions. Also up to 3 feet above floor or grade level within 25 feet horizontally from any edge of pump.
Lubrication or Service Room — with Dispensing	1	Any pit within any unventilated area.
	2	Any pit with ventilation.
	2	Space up to 18 inches above floor or grade level and 3 feet horizontally from a lubrication pit.
Dispenser for Class I Liquids	2	Within 3 feet of any fill or dispensing point, extending in all directions.
Lubrication or Service Room — without Dispensing	2	Entire space within any pit used for lubrication or similar services where Class I liquids may be released.
	2	Space up to 18 inches above any such pit, and extending a distance of 3 feet horizontally from any edge of the pit.



Table 514-2 (Continued)

Location	Class I, Group D Division	Extent of Class I Location
<b>Special Enclosure Inside Building</b> (See NFPA 30A-1984, Automotive and Marine Service Station Code, Section 2-2)	1	Entire enclosure.
<b>Sales, Storage and Rest Rooms</b>	Ordinary	If there is any opening to these rooms within the extent of a Division 1 location, the entire room shall be classified as Division 1.
<b>Vapor Processing Systems Pits</b>	1	Any pit, box, or space below grade level, any part of which is within a Division 1 or 2 location or which houses any equipment used to transport or process vapors.
<b>Vapor Processing Equipment Located Within Protective Enclosures</b>	2	Within any protective enclosure housing vapor processing equipment.
<b>Vapor Processing Equipment Not Within Protective Enclosures</b> (excluding piping and combustion devices)	2	The space within 18 inches in all directions of equipment containing flammable vapor or liquid extending to grade level. Up to 18 inches above grade level within 10 feet horizontally of the vapor processing equipment.
<b>Equipment Enclosures</b>	1	Any space within the enclosure where vapor or liquid is present under normal operating conditions.
	2	The entire space within the enclosure other than Division 1.
<b>Vacuum Assist Blowers</b>	2	The space within 18 inches in all directions extending to grade level. Up to 18 inches above grade level within 10 feet horizontally.

For SI units: one inch = 25.4 millimeters; one foot = 0.3048 meter.

**514-4. Wiring and Equipment Above Class I Locations.** Wiring and equipment above the Class I locations defined in Section 514-2 shall comply with Sections 511-6 and 511-7.

**514-5. Circuit Disconnects.** Each circuit leading to or through a dispensing pump shall be provided with a switch or other acceptable means to disconnect simultaneously from the source of supply all conductors of the circuit, including the grounded neutral, if any.

**514-6. Sealing.**

(a) **At Dispenser.** An approved seal shall be provided in each conduit run entering or leaving a dispenser or any cavities or enclosures in direct communication therewith. The sealing fitting shall be the first fitting after the conduit emerges from the earth or concrete.

(b) **At Boundary.** Additional seals shall be provided in accordance with Section 501-5. Section 501-5(a)(4) and (b)(2) shall apply to horizontal as well as to vertical boundaries of the defined Class I locations.

**514-7. Grounding.** Metal portions of dispensing pumps, metal raceways, and all noncurrent-carrying metal parts of electric equipment, regardless of voltage, shall be grounded as provided in Article 250.

**514-8. Underground Wiring.** Underground wiring shall be installed in threaded rigid metal conduit or threaded steel intermediate metal conduit. Any portion of electrical wiring or equipment which is below the surface of a Class I, Division 1 or Division 2 location (as defined in Table 514-2) shall be considered to be in a Class I, Division 1 location, which shall extend at least to the point of emergence above grade. Refer to Exception No. 3 of Section 300-5(a).

*Exception No. 1: Type MI cable shall be permitted where it is installed in accordance with Article 330.*

*Exception No. 2: Rigid nonmetallic conduit complying with Article 347 shall be permitted when buried under not less than 2 feet (610 mm) of earth. Where rigid nonmetallic conduit is used, threaded rigid metal conduit or threaded steel intermediate metal conduit shall be used for the last 2 feet (610 mm) of the underground run to emergence or to the point of connection to the aboveground raceway; an equipment grounding conductor shall be included to provide electrical continuity of the raceway system and for grounding of noncurrent-carrying metal parts.*

## ARTICLE 515 — BULK STORAGE PLANTS

**515-1. Definition.** A bulk storage plant is a location where gasoline or other volatile flammable liquids are stored in tanks having an aggregate capacity of one carload or more, and from which such products are distributed (usually by tank truck).

**515-2.\* Class I Locations.** Table 515-2 shall be applied where Class I liquids are stored, handled, or dispensed and shall be used to delineate and classify bulk storage plants. The Class I location shall not extend beyond an unpierced wall, roof, or other solid partition.

**515-3. Wiring and Equipment Within Class I Locations.** All electric wiring and equipment within the Class I locations defined in Section 515-2 shall comply with the applicable provisions of Article 501.

*Exception: As permitted in Section 515-5.*

**515-4. Wiring and Equipment Above Class I Locations.** All fixed wiring above Class I locations shall be in metallic raceways or be Type MI, TC,

Table 515-2<sup>a</sup>. Class I Locations — Bulk Plants

Location	Class I, Group D Division	Extent of Class I Location
<b>Tank Vehicle and Tank Car</b> Loading Through Open Dome When classifying extent of space, consideration shall be given to fact that tank cars or tank vehicles may be spotted at varying points. Therefore, the extremities of the loading or unloading positions shall be used.	1	Within 3 feet of edge of dome, extending in all directions.
	2	Space between 3 feet and 15 feet from edge of dome, extending in all directions.
Loading Through Bottom Connections with Atmospheric Venting	1	Within 3 feet of point of venting to atmosphere, extending in all directions.
	2	Space between 3 feet and 15 feet from point of venting to atmosphere, extending in all directions. Also up to 18 inches above grade within a horizontal radius of 10 feet from point of loading connection.
Loading Through Closed Dome with Atmospheric Venting	1	Within 3 feet of open end of vent, extending in all directions.
	2	Space between 3 feet and 15 feet from open end of vent, extending in all directions. Also within 3 feet of edge of dome, extending in all directions.
Loading Through Closed Dome with Vapor Recovery	2	Within 3 feet of point of connection of both fill and vapor lines, extending in all directions.
Bottom Loading with Vapor Recovery or Any Bottom Unloading	2	Within 3 feet of point of connections, extending in all directions. Also up to 18 inches above grade within a horizontal radius of 10 feet from point of connection.
<b>Pumps, Bleeders, Withdrawal Fittings, Meters and Similar Devices</b> Indoors	2	Within 5 feet of any edge of such devices, extending in all directions. Also up to 3 feet above floor or grade level within 25 feet horizontally from any edge of such devices.
	2	Outdoors Within 3 feet of any edge of such devices, extending in all directions. Also up to 18 inches above grade level within 10 feet horizontally from any edge of such devices.

Table 515-2 (Continued)

Location	Class I, Group D Division	Extent of Class I Location
<b>Storage and Repair Garage for Tank Vehicles</b>	1  2	All pits or spaces below floor level.  Space up to 18 inches above floor or grade level for entire storage or repair garage.
<b>Drainage Ditches, Separators, Impounding Basins</b>	2	Space up to 18 inches above ditch, separator, or basin. Also up to 18 inches above grade within 15 feet horizontally from any edge.
<b>Garages for Other than Tank Vehicles</b>	Ordinary	If there is any opening to these rooms within the extent of an outdoor Division 1 or 2 location, the entire room shall be classified the same as the area classification at the point of the opening.
<b>Outdoor Drum Storage</b>	Ordinary	
<b>Indoor Warehousing Where There Is No Flammable Liquid Transfer</b>	Ordinary	If there is any opening to these rooms within the extent of an indoor Division 1 or 2 location, the room shall be classified the same as if the wall, curb or partition did not exist.
<b>Office and Rest Rooms</b>	Ordinary	
<b>Drum and Container Filling Outdoors, or Indoors with Adequate Ventilation</b>	1  2	Within 3 feet of vent and fill opening, extending in all directions.  Space between 3 feet and 5 feet from vent or fill opening, extending in all directions. Also up to 18 inches above floor or grade level within a horizontal radius of 10 feet from vent or fill opening.
<b>Tank — Aboveground*</b>		
Shell, Ends, or Roof and Dike Area	2	Within 10 feet from shell, ends, or roof of tank. Space inside dikes to level of top of dike.
Vent	1  2	Within 5 feet of open end of vent, extending in all directions.  Space between 5 feet and 10 feet from open end of vent, extending in all directions.
Floating Roof	1	Space above the roof and within the shell.

Table 515-2 (Continued)

Location	Class I, Group D Division	Extent of Class I Location
<b>Pits</b>		
Without Mechanical Ventilation	1	Entire space within pit if any part is within a Division 1 or 2 location.
With Mechanical Ventilation	2	Entire space within pit if any part is within a Division 1 or 2 location.
Containing Valves, Fittings or Piping, and Not Within a Division 1 or 2 Location	2	Entire pit.

For SI units: one inch = 25.4 millimeters; one foot = 0.3048 meter.

\* For Tanks — Underground, see Section 514-2.

SNM, or Type MC cable. Fixed equipment that may produce arcs, sparks, or particles of hot metal, such as lamps and lampholders for fixed lighting, cutouts, switches, receptacles, motors, or other equipment having make-and-break or sliding contacts, shall be of the totally enclosed type or be so constructed as to prevent escape of sparks or hot metal particles. Portable lamps or other utilization equipment and their flexible cords shall comply with the provisions of Article 501 for the class of location above which they are connected or used.

### 515-5. Underground Wiring.

(a) **Wiring Method.** Underground wiring shall be installed in threaded rigid metal conduit, threaded steel intermediate metal conduit, or where buried under not less than 2 feet (610 mm) of earth shall be permitted in rigid nonmetallic conduit or an approved cable. Where rigid nonmetallic conduit is used, threaded rigid metal conduit or threaded steel intermediate metal conduit shall be used for the last 2 feet (610 mm) of the conduit run to emergence or to the point of connection to the aboveground raceway. Where cable is used, it shall be enclosed in rigid or threaded steel intermediate metal conduit from the point of lowest buried cable level to the point of connection to the aboveground raceway.

(b) **Insulation.** Conductor insulation shall comply with Section 501-13.

(c) **Nonmetallic Wiring.** Where rigid nonmetallic conduit or cable with a nonmetallic sheath is used, an equipment grounding conductor shall be included to provide for electrical continuity of the raceway system and for grounding of noncurrent-carrying metal parts.

**515-6. Sealing.** Approved seals shall be provided in accordance with Section 501-5. Sealing requirements in Section 501-5(a)(4) and (b)(2) shall apply to horizontal as well as to vertical boundaries of the defined Class I locations. Buried raceways under defined Class I locations shall be considered to be within such locations.

**515-7. Gasoline Dispensing.** Where gasoline dispensing is carried on in conjunction with bulk station operations, the applicable provisions of Article 514 shall apply.

**515-8. Grounding.** All metal raceways and all noncurrent-carrying metal parts of electric equipment shall be grounded as provided in Article 250.

## ARTICLE 516 — SPRAY APPLICATION, DIPPING AND COATING PROCESSES

**516-1. Scope.** This article covers the regular or frequent application of flammable liquids, combustible liquids and combustible powders by spray operations and the application of flammable liquids, or combustible liquids at temperatures above their flashpoint, by dipping, coating, or other means.

(FPN): For further information regarding safeguards for these processes, such as fire protection, posting of warning signs, and maintenance, see Standard for Spray Application Using Flammable and Combustible Materials, NFPA 33-1985 (ANSI), and Standard for Dipping and Coating Processes Using Flammable or Combustible Liquids, NFPA 34-1982 (ANSI). For additional information regarding ventilation, see Blower and Exhaust Systems, Dust, Stock and Vapor Removal or Conveying, NFPA 91-1983.

**516-2. Classification of Locations.** Classification is based on dangerous quantities of flammable vapors, combustible mists, residues, dusts or deposits.

(a) **Class I or Class II, Division 1 Locations.** The following spaces shall be considered Class I or Class II, Division 1 locations as applicable.

(1)<sup>x</sup> The interiors of spray booths and rooms except as specifically provided in Section 516-3(d).

(2)<sup>x</sup> The interior of exhaust ducts.

(3)<sup>x</sup> Any area in the direct path of spray operations.

(4)<sup>x</sup> For dipping and coating operations, all space within 5 feet (1.52 m) in any direction from the vapor sources extending from these surfaces to the floor. The vapor source shall be the liquid surface in the dip tank, the wetted surface of the drain board and the surface of the dipped object over either the liquid surface or the wetted surface of the drain board and extending from these surfaces to the floor.

(5)<sup>x</sup> Pits within 25 feet (7.62 m) horizontally of the vapor source. If pits are in the classified area and extend beyond 25 feet (7.62 m) the Class I, Division 1 area shall include the entire pit unless a vapor stop is provided.

(b) **Class I or Class II, Division 2 Locations.** The following spaces shall be considered Class I or Class II, Division 2 as applicable.

(1)<sup>x</sup> For open spraying, all space outside of but within 20 feet (6.10 m) horizontally and 10 feet (3.05 m) vertically of the Class I, Division 1 location as defined in Section 516-2(a), and not separated from it by partitions. See Figure 1.

(2)<sup>x</sup> For spraying operations conducted within a closed top, open face, or front spray booth, the space shown in Figure 2, and the space within 3 feet (914 mm) in all directions from openings other than the open face or front.

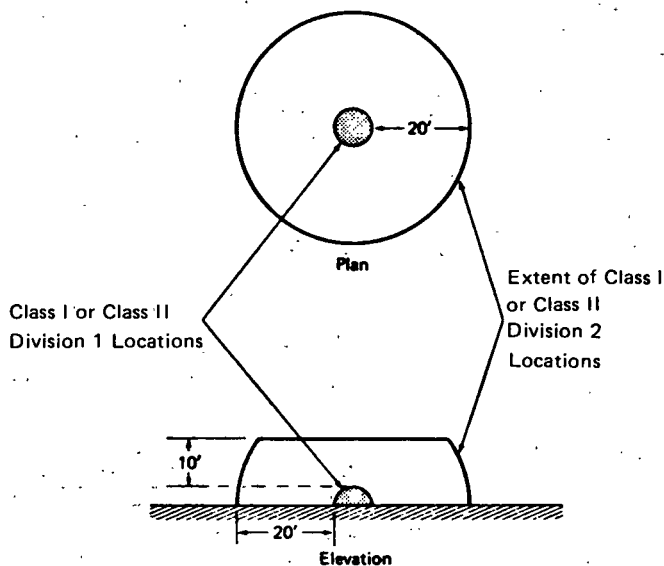

For SI units: one inch = 25.4 millimeters; one foot = 0.3048 meter.

**Figure 1.\* Class I or Class II, Division 2 Locations Adjacent to an Unenclosed Spray Operation.**

The Class I or Class II, Division 2 location shown in Figure 2 shall extend from the open face or front of the spray booth in accordance with the following:

a. If the ventilation system is interlocked with the spraying equipment so as to make the spraying equipment inoperable when the ventilation system is not in operation, the space shall extend 5 feet (1.52 m) from the open face or front of the spray booth, and as otherwise shown in Figure 2A.

b. If the ventilation system is not interlocked with the spraying equipment so as to make the spraying equipment inoperable when the ventilation system is not in operation, the space shall extend 10 feet (3.05 m) from the open face or front of the spray booth, and as otherwise shown in Figure 2B.

**(3)\*** For spraying operations conducted within an open top spray booth, the space 3 feet (914 mm) above the booth and within 3 feet (914 mm) of other booth openings shall be considered Class I or Class II, Division 2.

**(4)\*** For spraying operations confined to an enclosed spray booth or room, the space within 3 feet (914 mm) in all directions from any openings shall be considered Class I or Class II, Division 2 as shown in Figure 3.

**(5)\*** For dip tanks and drain boards, and for other hazardous operations, all space beyond the limits for Class I, Division 1 and within 8 feet (2.44 m) of the vapor source as defined in (a)(4). In addition, all space from the floor

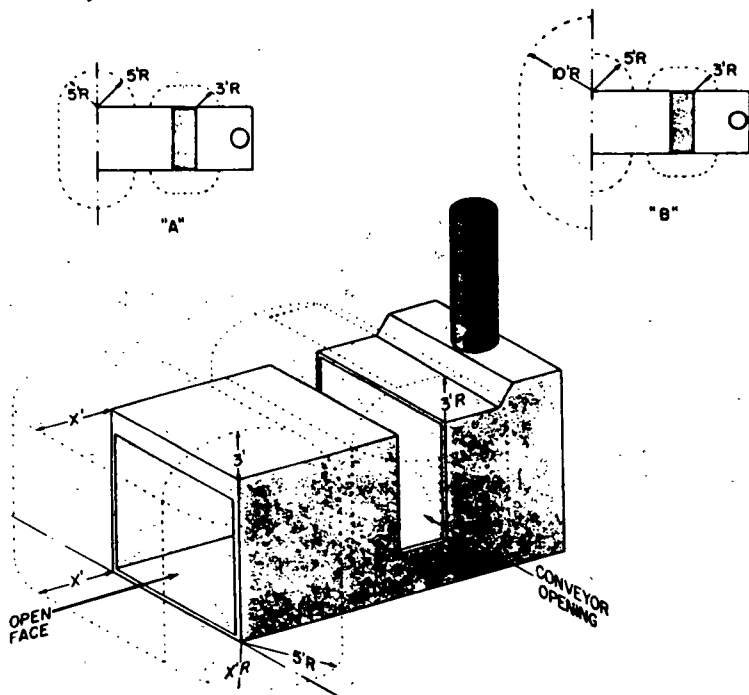

For SI units: one inch = 25.4 millimeters; one foot = 0.3048 meter.

- A. When ventilation system is interlocked with spray equipment.
- B. When ventilation system is not interlocked with spray equipment.

**Figure 2.\* Class I or Class II, Division 2 Locations Adjacent to a Closed Top, Open Faced or Open Front Spray Booth.**

to 3 feet (914 mm) above the floor, and extending 25 feet (7.62 m) horizontally from the vapor source as defined in (a)(4) as shown in Figure 4.

(c) **Adjacent Locations.** Adjacent locations that are cut off from the defined Class I or Class II locations by tight partitions without communicating openings; and within which hazardous vapors or combustible powders are not likely to be released, shall be classified as nonhazardous.

(d) **Nonhazardous Locations.** Locations utilizing drying, curing, or fusion apparatus and provided with positive mechanical ventilation adequate to prevent accumulation of flammable concentrations of vapors, and provided with effective interlocks to de-energize all electric equipment (other than equipment approved for Class I locations) in case the ventilating equipment



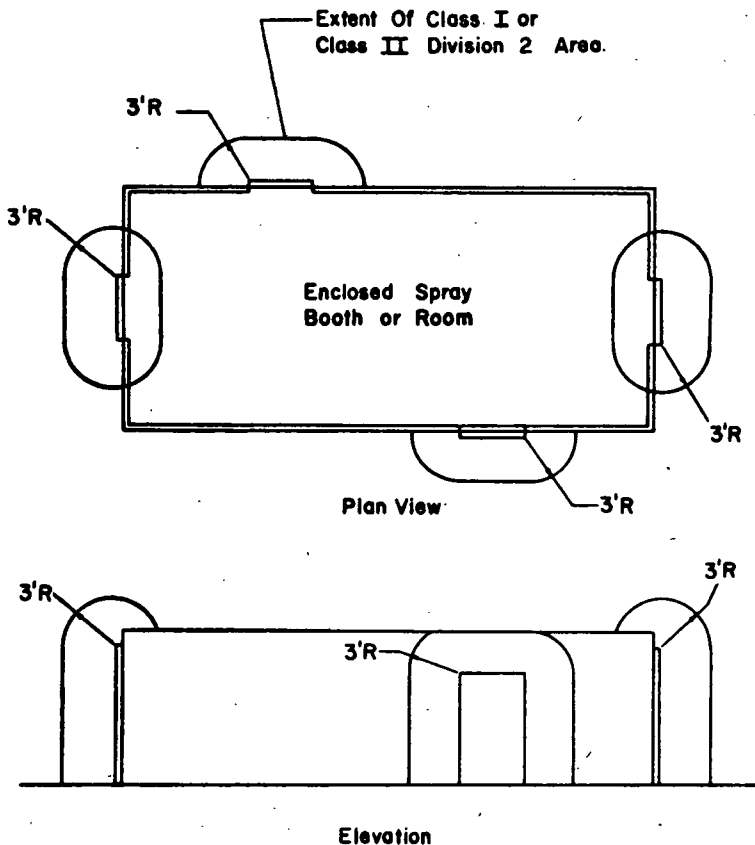

For SI units: one inch = 25.4 millimeters; one foot = 0.3048 meter.

**Figure 3.2 Class I or Class II, Division 2 Locations Adjacent to Openings in an Enclosed Spray Booth or Room**

is inoperative, shall be permitted to be classified as nonhazardous where the authority having jurisdiction so judges.

(FPN): For further information regarding safeguards, see Ovens and Furnaces, Design, Location and Equipment, NFPA 86-1985 (ANSI).

### 516-3. Wiring and Equipment in Class I Locations.

(a) **Wiring and Equipment — Vapors.** All electric wiring and equipment within the Class I location (containing vapor only—not residues) defined in Section 516-2 shall comply with the applicable provisions of Article 501.

(b)<sup>x</sup> **Wiring and Equipment — Vapors and Residues.** Unless approved for both readily ignitable deposits and the flammable vapor location, no electric

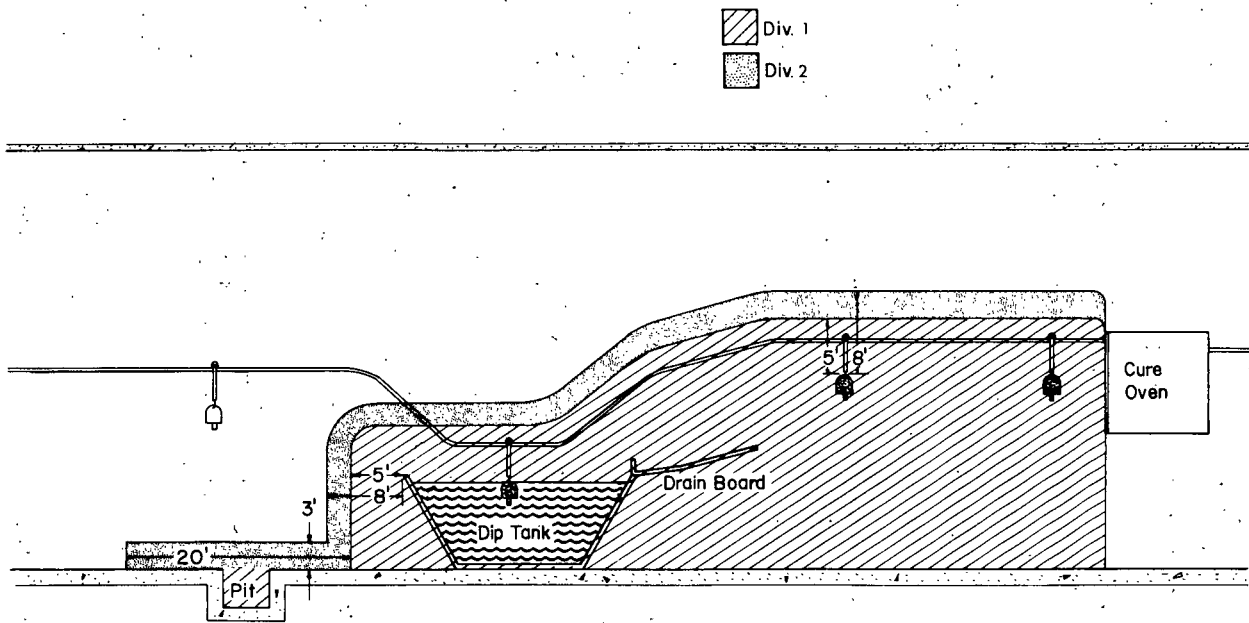

For SI units: one inch = 25.4 millimeters; one foot = 0.3048 meter.

Figure 4.\* The Extent of Class I, Division 1 and Class I, Division 2 Hazardous (Classified) Locations for a Paint Dipping Operation.

equipment shall be installed or used where it may be subject to hazardous accumulations of readily ignitable deposits or residues, as the susceptibility to spontaneous heating and ignition of some residues may be greatly increased with rise in temperature. Type MI cable and wiring in threaded rigid metal conduit or threaded steel intermediate metal conduit shall be permitted to be installed in such locations.

(c) **Illumination.** Illumination of readily ignitable areas through panels of glass or other transparent or translucent material shall be permitted only if it complies with the following: (1) fixed lighting units are used as the source of illumination; (2) the panel effectively isolates the Class I location from the area in which the lighting unit is located; (3) the lighting unit is approved for its specific location; (4) the panel is of a material or is so protected that breakage will be unlikely; and (5) the arrangement is such that normal accumulations of hazardous residue on the surface of the panel will not be raised to a dangerous temperature by radiation or conduction from the source of illumination.

(d)<sup>x</sup> **Portable Equipment.** Portable electric lamps or other utilization equipment shall not be used in a spray area during spray operations.

*Exception No. 1: Where portable electric lamps are required for operations in spaces not readily illuminated by fixed lighting within the spraying area, they shall be of the type approved for Class I, Division 1 locations where readily ignitable residues may be present.*

*Exception No. 2: Where portable electric drying apparatus are used in automobile refinishing spray booths and the following requirements are met: (1) the apparatus and its electrical connections are not located within the spray enclosure during spray operations; (2) electrical equipment within 18 inches (45.7 cm) of the floor is approved for Class I, Division 2 locations; (3) all metallic parts of the drying apparatus are electrically bonded and grounded; and (4) interlocks are provided to prevent the operation of spray equipment while drying apparatus is within the spray enclosure, to allow for a 3-minute purge of the enclosure before energizing the drying apparatus and to shut off drying apparatus on failure of ventilation system.*

(e) **Electrostatic Equipment.** Electrostatic spraying or detearing equipment shall be installed and used only as provided in Section 516-4.

(FPN): For further information, see Standard for Spray Application Using Flammable and Combustible Materials, NFPA 33-1985 (ANSI).

**516-4.<sup>x</sup> Fixed Electrostatic Equipment.** This section shall apply to any equipment using electrostatically charged elements for the atomization, charging, and/or precipitation of hazardous materials for coatings on articles or for other similar purposes in which the charging or atomizing device is attached to a mechanical support and is not hand held or manipulated. Where fixed electrostatic spraying and detearing equipment is installed, such equipment shall be of an approved type and shall comply with (a) through (h) below.

(a) **Power and Control Equipment.** Transformers, power packs, control apparatus, and all other electric portions of the equipment shall be installed outside of the Class I location as defined in Section 516-2 or be of a type approved for the location.

*Exception: High-voltage grids, electrodes, electrostatic atomizing heads, and their connections shall be permitted within the Class I location.*

(b) **Electrostatic Equipment.** Electrodes and electrostatic atomizing heads shall be: (1) located in suitable areas provided with adequate mechanical ventilation; (2) adequately supported in permanent locations; and (3) effectively insulated from ground. Electrodes and electrostatic atomizing heads that are permanently attached to their bases, supports, or reciprocators shall be considered as complying with this section. Insulators shall be nonporous.

Fine-wire elements, where used, shall be under tension at all times and be of uninked hardened steel or material of comparable strength.

(c) **High-Voltage Leads.** High-voltage leads shall be properly insulated and protected from mechanical injury or exposure to destructive chemicals. Any exposed element at high voltage shall be effectively and permanently supported on suitable insulators and shall be effectively guarded against accidental contact or grounding. An automatic means shall be provided for grounding the electrode system when the primary of its high-voltage supply is electrically de-energized for any reason.

(d) **Separation of Goods from Electrostatic Equipment.** A safe distance of at least twice the sparking distance shall be maintained between goods being painted and electrodes or electrostatic atomizing heads or conductors. A suitable sign indicating this safe distance shall be conspicuously posted near the assembly.

(e) **Support of Goods.** Goods being coated or deteared shall be supported on conveyors or hangers. The conveyors or hangers shall be so arranged as to assure that the parts being coated or deteared are electrically connected to ground with a resistance of 1 megohm or less, and to maintain safe distances between goods and the electrodes or electrostatic atomizing heads at all times. Goods shall be supported to prevent such swinging or movement which would reduce the clearance to less than that specified in (d) above.

(f) **Automatic Controls.** Electrostatic apparatus shall be equipped with automatic means which will rapidly de-energize the high-voltage elements under any of the following conditions: (1) stoppage of ventilating fans or failure of ventilating equipment from any cause; (2) stoppage of the conveyor carrying goods through the high-voltage field; (3) occurrence of a ground or excessive current leakage at any point in the high-voltage system; (4) de-energizing of the high voltage supply; (5) reduction of clearances below that specified in (d) above.

(g) **Grounding.** All electrically conductive objects within the charging influence of the electrodes except those required by the process to be at high voltage shall be adequately grounded. This requirement shall apply to paint containers, wash cans, guards, and any other electrically conductive objects or devices in the area. The equipment shall carry a prominent permanently installed warning regarding the necessity for grounding these objects.

(h) **Isolation.** Safeguards such as adequate booths, fencing, railings or other means shall be placed about the equipment so that they, either by their location or character, or both, assure that a safe isolation of the process is maintained from plant storage or personnel.

**516-5.\* Electrostatic Hand-Spraying Equipment.** This section shall apply to any equipment using electrostatically charged elements for the atomization, charging, and/or precipitation of materials for coatings on articles, or for other similar purposes in which the atomizing device is hand held or

manipulated during the spraying operation. Electrostatic hand-spraying equipment and devices used in connection with paint-spraying operations shall be of approved types and shall comply with (a) through (e) below.

**(a) General.** The high-voltage circuits shall be designed so as not to produce a spark of sufficient intensity to ignite the most readily ignitable of those vapor-air mixtures likely to be encountered, nor result in appreciable shock hazard upon coming in contact with a grounded object under all normal operating conditions. The electrostatically charged exposed elements of the hand gun shall be capable of being energized only by an actuator which also controls the coating material supply.

**(b) Power Equipment.** Transformers, power packs, control apparatus, and all other electric portions of the equipment shall be located outside of the Class I location or be approved for the location.

*Exception: The hand gun itself and its connections to the power supply shall be permitted within the Class I location.*

**(c) Handle.** The handle of the spraying gun shall be electrically connected to ground by a metallic connection and be so constructed that the operator in normal operating position is in intimate electrical contact with the grounded handle to prevent buildup of a static charge on the operator's body. Signs indicating the necessity for grounding other persons entering the spray area shall be conspicuously posted.

**(d) Electrostatic Equipment.** All electrically conductive objects in the spraying area shall be adequately grounded. This requirement shall apply to paint containers, wash cans, and any other electrically conductive objects or devices in the area. The equipment shall carry a prominent, permanently installed warning regarding the necessity for this grounding feature.

**(e) Support of Objects.** Objects being painted shall be maintained in metallic contact with the conveyor or other grounded support. Hooks shall be regularly cleaned to ensure adequate grounding of 1 megohm or less. Areas of contact shall be sharp points or knife edges where possible. Points of support of the object shall be concealed from random spray where feasible; and where the objects being sprayed are supported from a conveyor, the point of attachment to the conveyor shall be so located as to not collect spray material during normal operation.

**516-6.\* Powder Coating.** This section shall apply to processes in which combustible dry powders are applied. The hazards associated with combustible dusts are present in such a process to a degree, depending upon the chemical composition of the material, particle size, shape, and distribution.

(FPN): The hazards associated with combustible dusts are inherent in this process. Generally speaking, the hazard rating of the powders employed is dependent upon the chemical composition of the material, particle size, shape, and distribution.

**(a) Electric Equipment and Sources of Ignition.** Electric equipment and other sources of ignition shall comply with the requirements of Article 502. Portable electric lamps and other utilization equipment shall not be used within a Class II location during operation of the finishing processes. When such lamps or utilization equipment are used during cleaning or repairing operations, they shall be of a type approved for Class II, Division I locations, and all exposed metal parts shall be effectively grounded.

*Exception:* Where portable electric lamps are required for operations in spaces not readily illuminated by fixed lighting within the spraying area, they shall be of the type approved for Class II, Division 1 locations where readily ignitable residues may be present.

(b) **Fixed Electrostatic Spraying Equipment.** The provisions of Sections 516-4 and (a) above shall apply to fixed electrostatic spraying equipment.

(c) **Electrostatic Hand-Spraying Equipment.** The provisions of Sections 516-5 and (a) above shall apply to electrostatic hand-spraying equipment.

(d) **Electrostatic Fluidized Beds.** Electrostatic fluidized beds and associated equipment shall be of approved types. The high-voltage circuits shall be so designed that any discharge produced when the charging electrodes of the bed are approached or contacted by a grounded object shall not be of sufficient intensity to ignite any powder-air mixture likely to be encountered nor to result in an appreciable shock hazard.

(1) Transformers, power packs, control apparatus, and all other electric portions of the equipment shall be located outside the powder-coating area or shall otherwise comply with the requirements of (a) above.

*Exception:* The charging electrodes and their connections to the power supply shall be permitted within the powder-coating area.

(2) All electrically conductive objects within the powder-coating area shall be adequately grounded. The powder-coating equipment shall carry a prominent, permanently installed warning regarding the necessity for grounding these objects.

(3) Objects being coated shall be maintained in electrical contact (less than 1 megohm) with the conveyor or other support in order to ensure proper grounding. Hangers shall be regularly cleaned to ensure effective electrical contact. Areas of electrical contact shall be sharp points or knife edges where possible.

(4) The electric equipment and compressed-air supplies shall be interlocked with a ventilation system so that the equipment cannot be operated unless the ventilating fans are in operation.

#### **516-7. Wiring and Equipment Above Class I and II Locations.**

(a) **Wiring.** All fixed wiring above the Class I and II locations shall be in metal raceways, rigid nonmetallic conduit, electrical nonmetallic tubing, or shall be Type MI, TC, SNM, or Type MC cable. Cellular metal floor raceways shall be permitted only for supplying ceiling outlets or extensions to the area below the floor of a Class I or II location, but such raceways shall have no connections leading into or through the Class I or II location above the floor unless suitable seals are provided.

(b) **Equipment.** Equipment that may produce arcs, sparks, or particles of hot metal, such as lamps and lampholders for fixed lighting; cutouts, switches, receptacles, motors, or other equipment having make-and-break or sliding contacts, where installed above a Class I or II location or above a location where freshly finished goods are handled, shall be of the totally enclosed type or be so constructed as to prevent escape of sparks or hot metal particles.

**516-8. Grounding.** All metal raceways and all noncurrent-carrying metal parts of fixed or portable equipment, regardless of voltage, shall be grounded as provided in Article 250.

## ARTICLE 517 — HEALTH CARE FACILITIES

### A. General

#### 517-1. Scope.

The provisions of this article shall apply to electrical construction and installation criteria in health care facilities.

(FPN): This article is not intended to apply to veterinary facilities:

(FPN): For information concerning performance, maintenance and testing criteria refer to the appropriate health care facilities documents:

#### 517-2. Definitions.

**Alternate Power Source.** One or more generator sets, or battery systems where permitted, intended to provide power during the interruption of the normal electrical services or the public utility electrical service intended to provide power during interruption of service normally provided by the generating facilities on the premises.

**Anesthetizing Location.** Any area of a health care facility which has been designated to be used for the administration of any flammable or nonflammable inhalation anesthetic agent in the course of examination or treatment including the use of such agents for relative analgesia.

**Critical Branch.** A subsystem of the emergency system consisting of feeders and branch circuits supplying energy to task illumination, special power circuits, and selected receptacles serving areas and functions related to patient care, and which are connected to alternate power sources by one or more transfer switches during interruption of the normal power source.

**Electrical Life Support Equipment.** Electrically powered equipment whose continuous operation is necessary to maintain a patient's life.

**Emergency System.** A system of feeders and branch circuits meeting the requirements of Article 700, and intended to supply alternate power to a limited number of prescribed functions vital to the protection of life and patient safety, with automatic restoration of electrical power within 10 seconds of power interruption.

**Equipment System.** A system of feeders and branch circuits arranged for delayed, automatic or manual connection to the alternate power source and which serves primarily 3-phase power equipment.

**Essential Electrical System.** A system comprised of alternate sources of power and all connected distribution systems and ancillary equipment, designed to assure continuity of electrical power to designated areas and functions of a health care facility during disruption of normal power sources, and also designed to minimize disruption within the internal wiring system.

**Exposed Conductive Surfaces.** Those surfaces which are capable of carrying electric current and which are unprotected, unenclosed, or un-

guarded, permitting personal contact. Paint, anodizing, and similar coatings are not considered suitable insulation, unless they are listed for the use.

**Flammable Anesthetics.** Gases or vapors such as fluroxene, cyclopropane, divinyl ether, ethyl chloride, ethyl ether, and ethylene, which may form flammable or explosive mixtures with air, oxygen, or reducing gases such as nitrous oxide.

**Flammable Anesthetizing Location.** Any area of the facility which has been designated to be used for the administration of any flammable inhalation anesthetic agents in the normal course of examination or treatment:

**Hazard Current.** For a given set of connections in an isolated power system, the total current that would flow through a low impedance if it were connected between either isolated conductor and ground.

**FAULT HAZARD CURRENT:** The hazard current of a given isolated system with all devices connected except the line isolation monitor:

**MONITOR HAZARD CURRENT:** The hazard current of the line isolation monitor alone.

**TOTAL HAZARD CURRENT:** The hazard current of a given isolated system with all devices, including the line isolation monitor, connected.

**Health Care Facilities.** Buildings or parts of buildings that contain but are not limited to occupancies such as: hospitals, nursing homes, residential custodial care facilities, supervisory care facilities, clinics, medical and dental offices, and ambulatory health care facilities, whether fixed or mobile.

**Hospital.** A building or part thereof used for the medical, psychiatric, obstetrical or surgical care, on a 24-hour basis, of four or more inpatients. Hospital, wherever used in this Code, shall include general hospitals, mental hospitals, tuberculosis hospitals, children's hospitals, and any such facilities providing inpatient care.

**Isolated Power System.** A system comprising an isolating transformer or its equivalent, a line isolation monitor, and its ungrounded circuit conductors.

**Isolation Transformer.** A transformer of the multiple-winding type, with the primary and secondary windings physically separated, which inductively couples its secondary winding to the grounded feeder systems that energize its primary winding.

**Life Safety Branch.** A subsystem of the emergency system consisting of feeders and branch circuits, meeting the requirements of Article 700 and intended to provide adequate power needs to ensure safety to patients and personnel, and which are automatically connected to alternate power sources during interruption of the normal power source.

**Line Isolation Monitor.** A test instrument designed to continually check the balanced and unbalanced impedance from each line of an isolated circuit to ground and equipped with a built-in test circuit to exercise the alarm without adding to the leakage current hazard.

(FPN): "Line isolation monitor" was formerly known as "ground contact indicator."

**Nursing Home.** A building or part thereof used for the lodging, boarding and nursing care, on a 24-hour basis, of four or more persons who, because of mental or physical incapacity, may be unable to provide for their own needs and safety without the assistance of another person. Nursing home, wherever used in this Code, shall include nursing and convalescent homes,



skilled nursing facilities, intermediate care facilities, and infirmaries of homes for the aged.

**Nurses' Stations.** Areas intended to provide a center of nursing activity for a group of nurses serving bed patients, where the patient calls are received, nurses are dispatched, nurses' notes written, inpatient charts prepared, and medications prepared for distribution to patients. Where such activities are carried on in more than one location within a nursing unit, all such separate areas are considered a part of the nurses' station.

**Patient Equipment Grounding Point.** A jack or terminal bus which serves as the collection point for redundant grounding of electric appliances serving a patient vicinity or for grounding other items in order to eliminate electromagnetic interference problems.

**Patient Vicinity.** In an area in which patients are normally cared for, the patient vicinity is the space with surfaces likely to be contacted by the patient or an attendant who can touch the patient. Typically in a patient room, this encloses a space within the room not less than 6 feet (1.83 m) beyond the perimeter of the bed in its nominal location, and extending vertically not less than 7½ feet (2.29 m) above the floor.

**Psychiatric Hospital.** A building used exclusively for the psychiatric care, on a 24-hour basis, of four or more inpatients.

**Reference Grounding Point.** A terminal bus which is the equipment grounding bus or an extension of the equipment grounding bus and is a convenient collection point for installed grounding wires or other bonding wires where used.

**Residential Custodial Care Facility.** A building, or part thereof, used for the lodging or boarding of four or more persons who may be incapable of self-preservation because of age, or physical or mental limitation. This includes facilities such as homes for the aged, nurseries (custodial care for children under 6 years of age), and mentally retarded care institutions. Day care facilities that do not provide lodging or boarding for institutional occupants are not classified as residential custodial care facilities.

**Room Bonding Point.** A grounding terminal or group of terminals which serves as a collection point for grounding exposed metal or conductive building surfaces in a room.

**Selected Receptacles.** A minimum number of electrical receptacles to accommodate appliances ordinarily required for local tasks or likely to be used in patient care emergencies.

**Task Illumination.** Provision for the minimum lighting required to carry out necessary tasks in the described areas, including safe access to supplies and equipment, and access to exits.

**Therapeutic High-Frequency Diathermy Equipment.** Therapeutic high-frequency diathermy equipment is therapeutic induction and dielectric heating equipment.

**Wet Location, Health Care Facility.** A patient care area that is normally subject to wet conditions, including standing water on the floor, or routine dousing or drenching of the work area. Routine housekeeping procedures and incidental spillage of liquids do not define a wet location.

**517-3. General.** The requirements in Parts C, D, and E apply not only to single-function buildings, but are also intended to be individually applied to

their respective forms of occupancy within a multifunction building (i.e., a doctor's examining room located within a residential custodial care facility would be required to meet the provisions of Part C).

## B. Wiring Systems — General

**517-6. Applicability.** Part B shall apply to all health care facilities. Installations in facilities which provide patient care, equipment or services identified in other parts of this article shall also comply with the requirements of that part.

**517-10. Wiring Methods.** Except as modified in this article, wiring methods shall comply with the applicable requirements of Chapters 1 through 4 of this Code.

**517-11. Grounding of Receptacles and Fixed Electrical Equipment.** In areas used for patient care, the grounding terminals of all receptacles and all noncurrent-carrying conductive surfaces of fixed electrical equipment likely to become energized that are subject to personal contact, operating at over 100 volts, shall be grounded by an insulated copper conductor. The grounding conductor shall be sized in accordance with Table 250-95 and installed in metal raceways with the branch-circuit conductors supplying these receptacles or fixed equipment.

*Exception No. 1: Metal raceways are not required where Type MC cable, Type MI cable, or Type AC cable with an insulated grounding conductor is used.*

*Exception No. 2: Metal faceplates shall be permitted to be grounded by means of a metal mounting screw(s) securing the faceplate to a grounded outlet-box or grounded wiring device.*

*Exception No. 3: An equipment grounding conductor enclosed in the sheath of a nonmetallic-sheathed cable assembly installed in accordance with the limitations of Sections 336-2, 336-3, and 336-4 shall be permitted to be used in accordance with Parts C and D of this article.*

**517-13. Receptacles with Insulated Grounding Terminals.** Receptacles with insulated grounding terminals as permitted in Section 250-74, Exception No. 4, shall be identified; such identification shall be visible after installation.

(FPN): Care is important in specifying such a system with receptacle insulated grounds since the grounding impedance is controlled only by the grounding wires and does not benefit functionally from any parallel grounding paths.

### 517-14. Ground-Fault Protection.

(a) **Feeders.** When ground-fault protection is provided for operation of the service disconnecting means, an additional step of ground-fault protection shall be provided in the next level of feeder downstream toward the load. Such protection shall consist of overcurrent devices and current transformers or other equivalent protective equipment which shall cause the feeder disconnecting devices to open.

(b) **Selectivity.** Ground-fault protection for operation of the service and feeder disconnecting means shall be fully selective such that the feeder device and not the service device shall open on ground faults on the load side of the feeder device. A six-cycle minimum separation between the service

and feeder ground-fault tripping bands shall be provided. Operating time of the disconnecting devices shall be considered in selecting the time spread between these two bands to achieve 100 percent selectivity.

(FPN): See Section 230-95; Fine Print Note, for transfer of alternate source where ground-fault protection is applied.

(c) **Testing.** When equipment ground-fault protection is first installed, each level shall be performance tested to ensure compliance with (b) above.

### **C. Clinics, Medical and Dental Offices, Outpatient Facilities, and Other Health Care Facilities Not Covered in Parts D and E**

**517-30. Applicability.** Part C shall apply to those portions of clinics, medical and dental offices, and outpatient facilities wherein patients are intended to be examined or treated. It shall not apply to business offices, corridors, waiting rooms, and the like.

**517-31. Wiring, Grounding and Receptacles.** Wiring, grounding and receptacle installations shall be in accordance with Sections 517-10 and 517-11.

#### **517-32.\* Essential Electrical System.**

(a) **General.** The requirements of this section shall apply to those health care facilities described in Section 517-30, in which:

(1) Inhalation anesthetics are administered in any concentration to patients, or

(2) Patients require electrically operated or mechanical life support devices.

(b) **Scope.** The essential electrical system for these facilities shall comprise a system capable of supplying a limited amount of lighting and power service which is considered essential for life safety and orderly cessation of procedures during the time normal electrical service is interrupted for any reason.

(c) **Connections.** The essential electrical system shall supply power for:

(1) Task illumination which is related to the safety of life and which is necessary for the safe cessation of procedures in progress.

(2) All anesthesia and resuscitative equipment used in areas where inhalation anesthetics are administered to patients including alarm and alerting devices.

(FPN): See Nonflammable Medical Gas Systems, NFPA 56F-1983 (ANSI), Chapters 3 and 6.

(3) All electrically operated and mechanical equipment in areas where procedures are performed that require such equipment for the support of the patient's life.

(d) **Alternate Source of Power.**

(1) **Power Source.** The alternate source of power for the system shall be specifically designed for this purpose and shall be either a generator, battery system or self-contained battery integral with the equipment.

(2) **System Capacity.** The alternate source of power shall be separate and independent of the normal source and shall have a capacity to sustain its connected loads for a minimum of 1½ hours after loss of the normal source.

**(3) System Operation.** The system shall be so arranged that, in the event of a failure of the normal power source, the alternate source of power shall be automatically connected to the load within 10 seconds.

(FPN): See Health Care Facilities, NFPA 99-1984 (ANSI), Sections 8-5.5.2, Description of Transfer Switch Operation with Engine Generator Sets, and 8-5.5.3, Description of Transfer Switch Operation with Battery Systems.

#### **D. Nursing Homes and Residential Custodial Care Facilities**

(FPN): For performance, maintenance and testing requirements of essential electrical systems in nursing homes and residential custodial care facilities, see Health Care Facilities, NFPA 99-1984 (ANSI).

**517-40.\* Applicability.** The requirements of Part D, Sections 517-42 through 517-47, shall apply to nursing homes and residential custodial care facilities.

*Exception: Any free-standing building used for health care other than those described in Parts C and E of this article shall be exempted from the requirements of Sections 517-44 through 517-47 provided:*

*a. It maintains admitting and discharge policies that preclude the provision of care for any patient or resident who may need to be sustained by electrical life support equipment, and*

*b. Offers no surgical treatment requiring general anesthesia, and*

*c. Provides an automatic battery-operated system(s) or equipment that shall be effective for at least 1½ hours and is otherwise in accordance with Section 700-12, and that shall be capable of supplying lighting for exit lights, exit corridors, stairways, nursing stations, medical preparation areas, boiler rooms and communication areas. This system shall also supply battery power to operate all alarm systems.*

(FPN): See Life Safety Code, NFPA 101-1985 (ANSI).

**517-41. Inpatient Hospital Care Facilities.** Nursing homes and residential custodial care facilities which provide inpatient hospital care shall comply with the requirements of Part E, Hospitals.

**517-42. Facilities Contiguous with Hospitals.** Nursing homes and residential custodial care facilities which are contiguous with a hospital shall be permitted to have their essential electrical systems supplied by that of the hospital.

**517-43. Wiring, Grounding, and Receptacles.** Wiring, grounding, and receptacle installation shall be in accordance with Sections 517-10 and 517-11.

*Exception: Patient sleeping areas wired in accordance with the requirements of Chapters 1 through 4 of this Code.*

**517-44. Essential Electrical Systems.**

(a)\* **General.** Essential electrical systems for nursing homes and residential custodial care facilities shall be comprised of two separate branches capable of supplying a limited amount of lighting and power service which is considered essential for the protection of life safety and effective operation of the institution during the time normal electrical service is interrupted for any

SMALL ELECTRICAL SYSTEM — NURSING HOMES  
AND RESIDENTIAL CUSTODIAL  
CARE FACILITIES

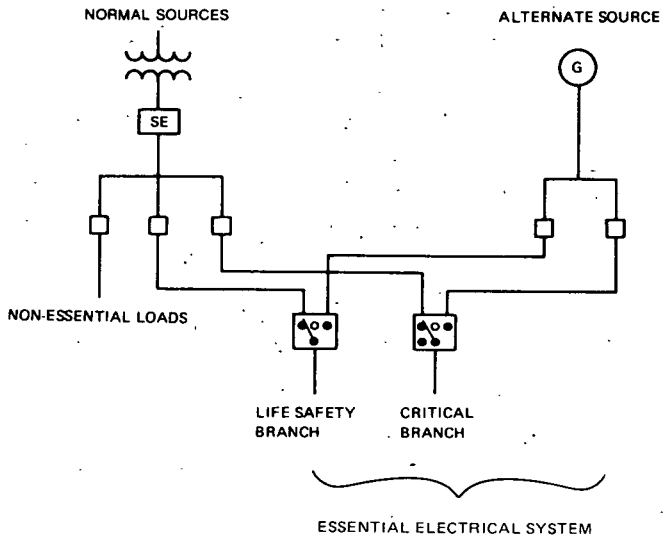

SE SERVICE ENTRANCE

□ OVERCURRENT PROTECTION

⊠ AUTOMATIC SWITCHING EQUIPMENT

⊠ DELAYED AUTOMATIC SWITCHING EQUIPMENT

⊞ TRANSFORMER

⊙ GENERATOR

Diagram 517-44(1)

TYPICAL LARGE ELECTRICAL SYSTEM - NURSING HOMES AND RESIDENTIAL  
CUSTODIAL CARE FACILITIES

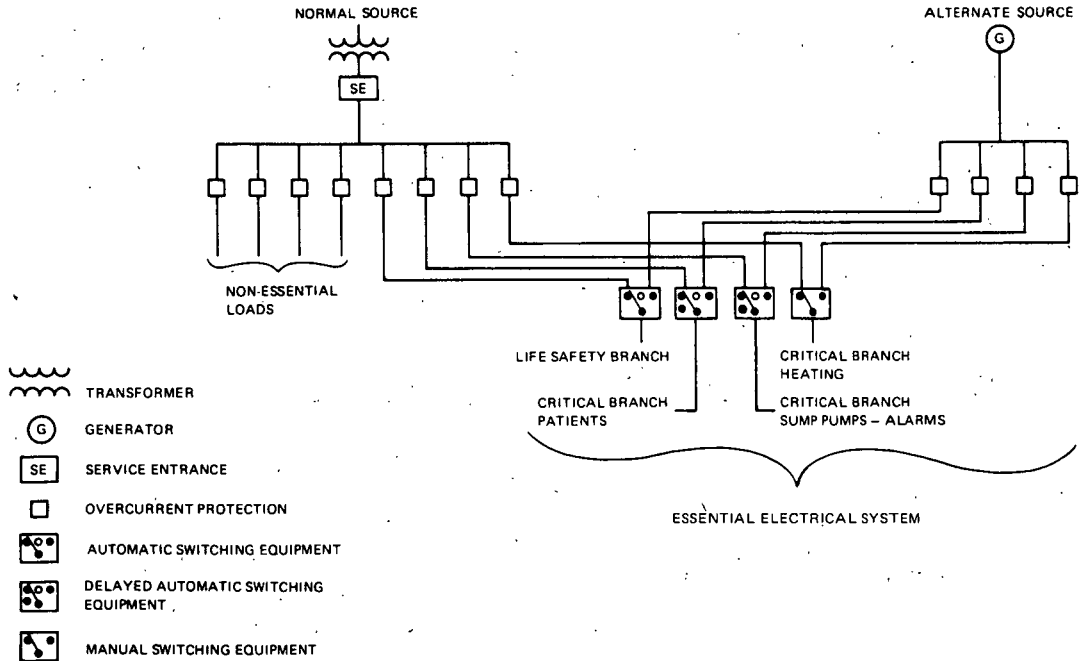
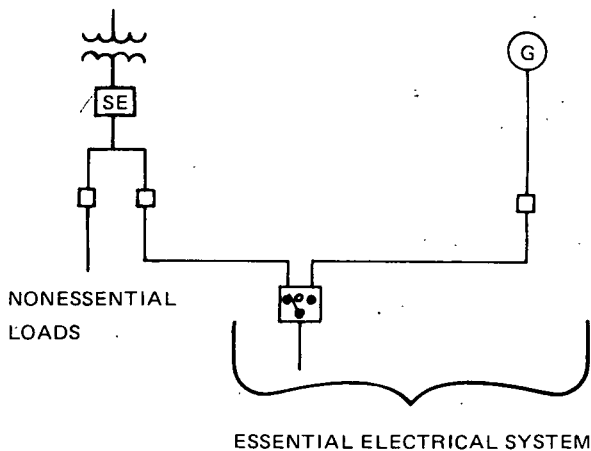







Diagram 517-44(2)

**SMALL ELECTRICAL SYSTEM--- NURSING HOMES  
AND RESIDENTIAL CUSTODIAL  
CARE FACILITIES  
(SINGLE TRANSFER SWITCH)**

NORMAL SOURCES

ALTERNATE SOURCE



-  SERVICE ENTRANCE
-  OVERCURRENT PROTECTION
-  AUTOMATIC SWITCHING EQUIPMENT
-  TRANSFORMER
-  GENERATOR

**Diagram 517-44(3)**

reason. These two separate branches shall be the life safety branch and the critical branch.

**(b)\* Transfer Switches.** The number of transfer switches to be used shall be based upon reliability, design, and load considerations. Each branch of the essential electrical system shall be served by one or more transfer switches as shown in Diagrams 517-44(1) and 517-44(2). One transfer switch shall be permitted to serve one or more branches in a facility with a maximum demand on the essential electrical system of 150 kVA.

(FPN): See Health Care Facilities, NFPA 99-1984 (ANSI): Section 8-4.5.2, Description of Transfer Switch Operation; Section 8-2.2.4, Automatic Transfer Switch Features; and Section 8-2.2.4, Nonautomatic Transfer Device Features.

**(c) Capacity of System.** The essential electrical system shall have adequate capacity to meet the demand for the operation of all functions and equipment to be served by each branch at one time.

**(d) Separation from Other Circuits.** The life safety branch shall be kept entirely independent of all other wiring and equipment and shall not enter the same raceways, boxes or cabinets with other wiring except as follows:

- (1) In transfer switches,
- (2) In exit or emergency lighting fixtures supplied from two sources, or
- (3) In a common junction box attached to exit or emergency lighting fixtures supplied from two sources.

The wiring of the critical branch shall be permitted to occupy the same raceways, boxes or cabinets of other circuits that are not part of the life safety branch.

**517-45\*. Automatic Connection to Life Safety Branch.** The life safety branch shall be so installed and connected to the alternate source of power that all functions specified herein shall be automatically restored to operation within 10 seconds after the interruption of the normal source. The life safety branch shall supply power for the following lighting, receptacles, and equipment:

(FPN): The life safety branch is called the emergency system in Health Care Facilities, NFPA 99-1984 (ANSI).

**(a) Illumination of Means of Egress.** Illumination of means of egress as is necessary for corridors, passageways, stairways, landings and exit doors and all ways of approach to exits. Switching arrangement to transfer patient corridor lighting from general illumination circuits shall be permitted providing only one of two circuits can be selected, and both circuits cannot be extinguished at the same time.

(FPN): See Life Safety Code, NFPA 101-1985 (ANSI), Section 5-10.

**(b) Exit Signs.** Exit signs and exit directional signs.

(FPN): See Life Safety Code, NFPA 101-1985 (ANSI), Section 5-11.

**(c) Alarm and Alerting Systems.** Alarm and alerting systems, including:

(1) Fire alarms activated at manual stations, electric water flow alarm devices in connection with sprinkler systems; and automatic fire or smoke or products of combustion detection devices.

(FPN): See Life Safety Code, NFPA 101-1985 (ANSI), Sections 7-6, 12-3.4, and 12-3.5.

(2) Alarms required for systems used for the piping of nonflammable medical gases.



(FPN): See Standard for Nonflammable Medical Gas Systems, NFPA 56F-1983 (ANSI).

**(d) Communication Systems.** Communication systems, where used for issuing instructions during emergency conditions.

**(e) Dining and Recreation Areas.** Sufficient lighting in dining and recreation areas to provide illumination to exit ways.

**(f) Generator Set Location.** Task illumination and selected receptacles in the generator set location.

**(g) Elevator Cab Lighting, Control and Communication Systems.** No function other than those listed in (a) through (g) shall be connected to the life safety branch.

**517-46<sup>a</sup>. Connection to Critical Branch.** The critical branch shall be so installed and connected to the alternate power source that the equipment listed in Section 517-46(a) shall be automatically restored to operation at appropriate time-lag intervals following the restoration of the life safety branch to operation. Its arrangement shall also provide for the additional connection of equipment listed in Section 517-46(b) by either delayed automatic or manual operation.

**(a) Delayed Automatic Connection.** The following equipment shall be connected to the critical branch and shall be arranged for delayed automatic connection to the alternate power source:

**(1) Patient care areas — task illumination and selected receptacles in:**

- a. Medication preparation areas.
- b. Pharmacy dispensing areas.
- c. Nurses' stations (unless adequately lighted by corridor luminaires).

**(2) Sump pumps and other equipment required to operate for the safety of major apparatus and associated control systems and alarms.**

**(b) Delayed Automatic or Manual Connection.** The following equipment shall be connected to the critical branch and shall be arranged for either delayed automatic or manual connection to the alternate power source:

**(1) Heating equipment to provide heating for patient rooms.**

*Exception: Heating of general patient rooms during disruption of the normal source shall not be required under any of the following conditions:*

- a. *The outside design temperature is higher than +20°F (-6.7°C), or*
- b. *The outside design temperature is lower than +20°F (-6.7°C) and where a selected room(s) is provided for the needs of all confined patients, then only such room(s) need be heated, or*
- c. *The facility is served by a dual source of normal power as described in Section 517-47(c), Fine Print Note.*

(FPN): The outside design temperature is based on the 97½ percent design values as shown in Chapter 4 of the ASHRAE Handbook of Fundamentals (1981).

**(2) Elevator Service.** In instances where disruption of power would result in elevators stopping between floors, throw-over facilities shall be provided to allow the temporary operation of any elevator for the release of passengers. For elevator cab lighting, control and signal system requirements, see Section 517-45(g).

(3) Additional illumination, receptacles, and equipment shall be permitted to be connected only to the critical branch.

#### 517-47. Sources of Power.

(a) **Two Independent Sources of Power.** Essential electrical systems shall have a minimum of two independent sources of power: a normal source generally supplying the entire electrical system, and one or more alternate sources for use when the normal source is interrupted.

(b)\* **Alternate Source of Power.** The alternate source of power shall be a generator(s) driven by some form of prime mover(s), and located on the premises.

*Exception No. 1: Where the normal source consists of generating units on the premises, the alternate source shall be either another generator set, or an external utility service.*

*Exception No. 2: Nursing homes or residential custodial care facilities meeting the requirements of the Exception to Section 517-40 shall be permitted to use a battery system or self-contained battery integral with the equipment.*

(c) **Location of Essential Electrical System Components.** Careful consideration shall be given to the location of the spaces housing the components of the essential electrical system to minimize interruptions caused by natural forces common to the area (e.g., storms, floods, earthquakes, or hazards created by adjoining structures or activities). Consideration shall also be given to the possible interruption of normal electrical services resulting from similar causes as well as possible disruption of normal electrical service due to internal wiring and equipment failures.

(FPN): Facilities whose normal source of power is supplied by two or more separate central station-fed services experience greater than normal electrical service reliability than those with only a single feed. Such a dual source of normal power consists of two or more electrical services fed from separate generator sets or a utility distribution network having multiple power input sources and arranged to provide mechanical and electrical separation so that a fault between the facility and the generating sources will not likely cause an interruption of more than one of the facility service feeders.

### E. Hospitals

(FPN): For performance, maintenance and testing requirements of essential electrical systems in hospitals, see Health Care Facilities, NFPA 99-1984 (ANSI). For installation of centrifugal fire pumps, see Standard for the Installation of Centrifugal Fire Pumps, NFPA 20-1983 (ANSI).

(FPN): For additional information, see Health Care Facilities, NFPA 99-1984 (ANSI).

**517-58. Applicability.** The requirements of Part E, Sections 517-60 through 517-65, shall apply to hospitals where an essential electrical system is required.

*Exception: Those facilities covered by Parts C and D.*

(FPN): For information as to the need for an essential electrical system, see Health Care Facilities, NFPA 99-1984 (ANSI).

**517-60. Essential Electrical Systems.****(a) General.**

(1)\* Essential electrical systems for hospitals shall be comprised of two separate systems capable of supplying a limited amount of lighting and power service which is considered essential for life safety and effective hospital operation during the time the normal electrical service is interrupted for any reason. These two systems shall be the emergency system and the equipment system.

(2)\* The emergency system shall be limited to circuits essential to life safety and critical patient care. These are designated the life safety branch and the critical branch.

(3)\* The equipment system shall supply major electrical equipment necessary for patient care and basic hospital operation.

(4)\* The number of transfer switches to be used shall be based upon reliability, design, and load considerations. Each branch of the essential electrical system shall be served by one or more transfer switches as shown in Diagrams 517-60(1) and 517-60(2). One transfer switch shall be permitted to serve one or more branches in a facility with a maximum demand on the essential electrical system of 150 kVA.

(FPN): See Health Care Facilities, NFPA 99-1984 (ANSI): Section 8-2.2.4, Automatic Transfer Switch Features; Section 8-4.5.2, Description of Transfer Switch Operation; and Section 8-2.2.4, Nonautomatic Transfer Device Features.

**(b) Wiring Requirements.**

(1) **Separation from Other Circuits.** The life safety branch and critical branch of the emergency system shall be kept entirely independent of all other wiring and equipment and shall not enter the same raceways, boxes or cabinets with each other or other wiring, except as follows:

- a. In transfer switches,
- b. In exit or emergency lighting fixtures supplied from two sources, or
- c. In a common junction box attached to exit or emergency lighting fixtures supplied from two sources.

The wiring of the equipment system shall be permitted to occupy the same raceways, boxes or cabinets of other circuits that are not part of the emergency system.

(2) **Isolated Power Systems.** Where isolated power systems are installed in any of the areas in Section 517-63(a)(1) and (a)(2), each system shall be supplied by an individual circuit serving no other load.

(3) **Mechanical Protection of the Emergency System.** The wiring of the emergency system of a hospital shall be mechanically protected by installation in metallic raceways.

*Exception No. 1: Flexible power cords of appliances, or other utilization equipment, connected to the emergency system shall not be required to be enclosed in raceways.*

*Exception No. 2: Secondary circuits of transformer-powered communication or signaling systems shall not be required to be enclosed in raceways unless otherwise specified by Chapter 7 or 8.*

*Exception No. 3: Branch-circuit wiring as permitted in Sections 517-101(b)(1) and (c)(1).*

## SMALL ELECTRICAL SYSTEM — HOSPITALS

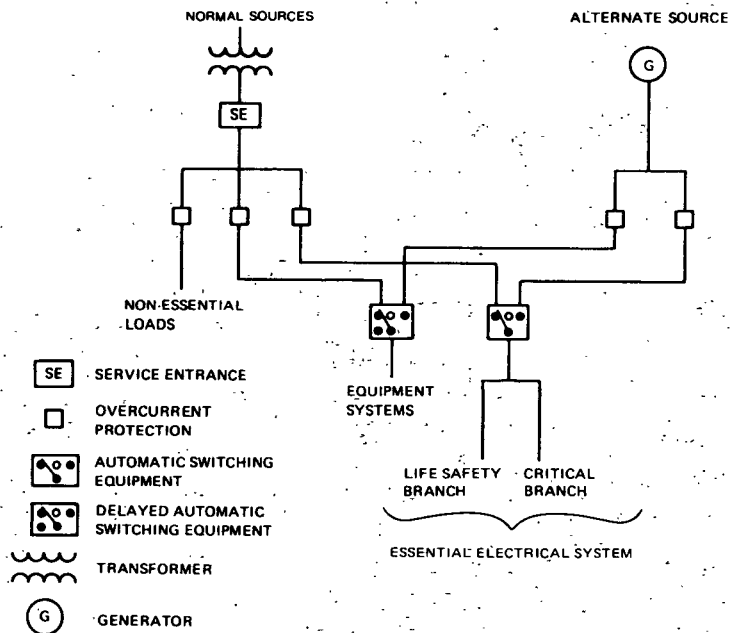

Diagram 517-60(1)

(c) **Capacity of Systems.** The essential electrical system shall have adequate capacity to meet the demand for the operation of all functions and equipment to be served by each system and branch.

**517-61<sup>x</sup>. Emergency System.** Those functions of patient care depending on lighting or appliances that are connected to the emergency system shall be divided into two mandatory branches: the life safety branch and the critical branch, described in Sections 517-62 and 517-63.

The branches of the emergency system shall be installed and connected to the alternate power source so that all functions specified herein for the emergency system shall be automatically restored to operation within 10 seconds after interruption of the normal source.

**517-62<sup>x</sup>. Life Safety Branch.** The life safety branch of the emergency system shall supply power for the following lighting, receptacles, and equipment:

(a) **Illumination of Means of Egress.** Illumination of means of egress, such as lighting required for corridors, passageways, stairways and landings at exit doors, and all necessary ways of approach to exits. Switching arrangements to transfer patient corridor lighting in hospitals from general illumination

## TYPICAL LARGE ELECTRICAL SYSTEM - HOSPITALS

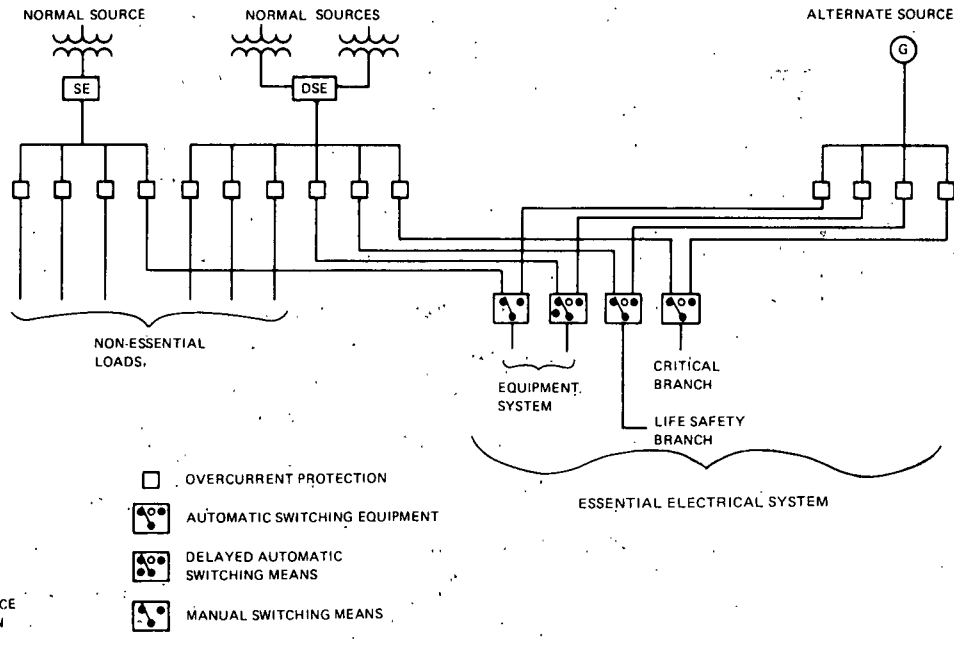

Diagram 517-60(2)

SMALL ELECTRICAL SYSTEM---HOSPITALS  
(SINGLE TRANSFER SWITCH)

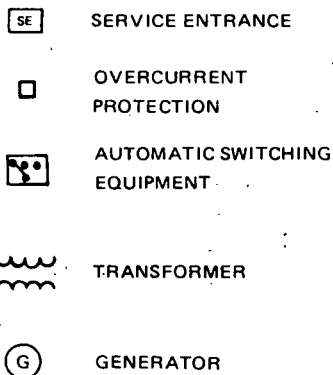
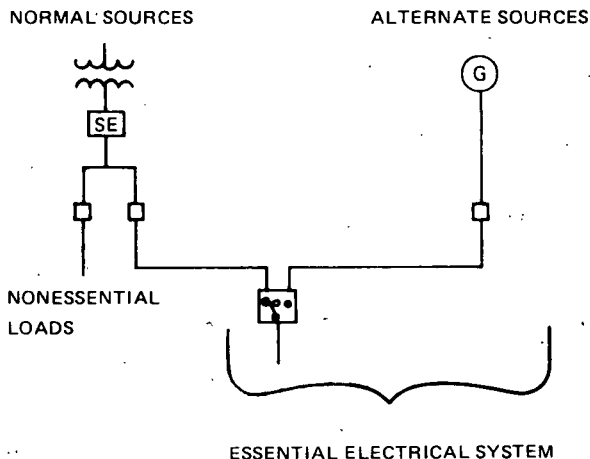

Diagram 517-60(3)

circuits to night illumination circuits shall be permitted provided only one of two circuits can be selected, and both circuits cannot be extinguished at the same time.

(FPN): See Life Safety Code, NFPA 101-1985 (ANSI), Section 5-10.

(b) **Exit Signs.** Exit signs and exit directional signs.

(FPN): See Life Safety Code, NFPA 101-1985 (ANSI), Section 5-11.

**(c) Alarm and Alerting Systems.** Alarm and alerting systems including:

(1) Fire alarms, actuated at manual stations.

(2) Electric water-flow alarm devices in connection with sprinkler systems.

(3) Automatic fire or smoke or products of combustion detection devices.

(FPN): See Life Safety Code, NFPA 101-1985 (ANSI), Sections 12-1 and 12-2.

(4) Alarms required for systems used for the piping of nonflammable medical gases.

(FPN): See Nonflammable Medical Gas Systems, NFPA 56F-1983 (ANSI).

**(d) Communication Systems.** Hospital communication systems, where used for issuing instructions during emergency conditions.

**(e) Generator Set Location.** Task illumination and selected receptacles at the generator set location.

**(f) Elevator Cab Lighting, Control and Signal Systems.** No function other than those listed in (a) through (f) shall be connected to the life safety branch.

### 517-63<sup>2</sup>. Critical Branch.

**(a) Task Illumination and Selected Receptacles.** The critical branch of the emergency system shall supply power for task illumination, fixed equipment, selected receptacles, and special power circuits serving the following areas and functions related to patient care.

(1) Anesthetizing locations — task illumination, all receptacles and fixed equipment.

(2) The isolated power systems in special environments.

(3) Patient care areas — task illumination and selected receptacles in:

a. Infant nurseries,

b. Medication preparation areas,

c. Pharmacy dispensing areas,

d. Selected acute nursing areas,

e. Psychiatric bed areas (omit receptacles);

f. Ward treatment rooms, and

g. Nurses' stations (unless adequately lighted by corridor luminaires).

(4) Additional specialized patient care task illumination and receptacles, where needed.

(5) Nurse call systems.

(6) Blood, bone and tissue banks.

(7) Telephone equipment room and closets.

(8) Task illumination, receptacles, and special power circuits for:

a. Acute care beds (selected),

b. Angiographic labs,

c. Cardiac catheterization labs,

d. Coronary care units,

e. Hemodialysis rooms or areas,

- f. Emergency room treatment areas (selected),
- g. Human physiology labs,
- h. Intensive care units, and
- i. Postoperative recovery rooms (selected).

(9) Additional task illumination, receptacles and special power circuits needed for effective hospital operation. Single-phase fractional horsepower exhaust fan motors which are interlocked with three-phase motors on the equipment shall be permitted to be connected to the critical branch.

**(b) Subdivision of the Critical Branch.** It shall be permitted to subdivide the critical branch into two or more branches.

(FPN): It is important to analyze the consequences of supplying an area with only critical care branch power when failure occurs between the area and the transfer switch. Some proportion of normal and critical power, or critical power from separate transfer switches, may be appropriate.

**517-64.\* Equipment System Connection to Alternate Power Source.** The equipment system shall be installed and connected to the alternate source, such that the equipment described in Section 517-64(a) is automatically restored to operation at appropriate time-lag intervals following the energizing of the emergency system. Its arrangement shall also provide for the subsequent connection of equipment described in Section 517-64(b).

**(a) Equipment for Delayed Automatic Connection.** The following equipment shall be arranged for delayed automatic connection to the alternate power source:

(1) Central suction systems serving medical and surgical functions, including controls. Such suction systems shall be permitted on the critical branch.

(2) Sump pumps and other equipment required to operate for the safety of major apparatus, including associated control systems and alarms.

(3) Compressed air systems serving medical and surgical functions, including controls.

(FPN): The above equipment may be arranged for sequential delayed automatic action to the alternate power source to prevent overloading the generator where engineering studies indicate it is necessary.

**(b) Equipment for Delayed Automatic or Manual Connection.** The following equipment shall be arranged for either delayed automatic or manual connection to the alternate power source:

(1) Heating equipment to provide heating for operating, delivery, labor, recovery, intensive care, coronary care, nurseries, and general patient rooms.

*Exception: Heating of general patient rooms and infection isolation rooms during disruption of the normal source shall not be required under any of the following conditions:*

- a. The outside design temperature is higher than +20°F (-6.7°C), or
- b. The outside design temperature is lower than +20°F (-6.7°C) and where a selected room(s) is provided for the needs of all confined patients then only such room(s) need be heated, or
- c. The facility is served by a dual source of normal power as described in Section 517-65(c), Fine Print Note.



(FPN): The design temperature is based on the 97½ percent design value as shown in Chapter 4 of the ASHRAE Handbook of Fundamentals (1981).

(2) Elevator(s) selected to provide service to patient, surgical, obstetrical and ground floors during interruption of normal power.

In instances where interruption of normal power would result in other elevators stopping between floors, throw-over facilities shall be provided to allow the temporary operation of any elevator for the release of patients or other persons who may be confined between floors.

(3) Supply and exhaust ventilating systems for surgical and obstetrical delivery suites, special and intensive care units, isolation rooms constructed specifically for infection control, emergency treatment spaces, and laboratory fume hoods.

(4) Hyperbaric facilities.

(5) Hypobaric facilities.

(6) Automatically operated doors.

(7) Minimal electrically heated autoclaving equipment shall be permitted to be arranged for either automatic or manual connection to the alternate source.

(8) Other selected equipment shall be permitted to be served by the equipment system.

#### 517-65. Sources of Power.

(a)<sup>x</sup> **Two Independent Sources of Power.** Essential electrical systems shall have a minimum of two independent sources of power: a normal source generally supplying the entire electrical system, and one or more alternate sources for use when the normal source is interrupted.

(b)<sup>x</sup> **Alternate Source of Power.** The alternate source of power shall be a generator(s) driven by some form of prime mover(s), and located on the premises.

*Exception: Where the normal source consists of generating units on the premises, the alternate source shall be either another generating set, or an external utility service.*

(c) **Location of Essential Electrical System Components.** Careful consideration shall be given to the location of the spaces housing the components of the essential electrical system to minimize interruptions caused by natural forces common to the area (e.g., storms, floods, earthquakes, or hazards created by adjoining structures or activities). Consideration shall also be given to the possible interruption of normal electrical services resulting from similar causes as well as possible disruption of normal electrical service due to internal wiring and equipment failures.

(FPN): Facilities whose normal source of power is supplied by two or more separate central station-fed services experience greater than normal electrical service reliability than those with only a single feed. Such a dual source of normal power consists of two or more electrical services fed from separate generator sets or a utility distribution network having multiple power input sources and arranged to provide mechanical and electrical separation so that a fault between the facility and the generating sources will not likely cause an interruption of more than one of the facility service feeders.

### F. Patient Care Areas

(FPN): See Health Care Facilities, NFPA 99-1984 (ANSI).

#### 517-80. General.

(a) **Installation/Construction Criteria.** It is the purpose of Part F to specify the installation criteria and/or wiring methods which will minimize electrical hazards by the maintenance of adequately low-potential differences only between exposed conductive surfaces which are likely to become energized and could be contacted by a patient.

(FPN): In a health care facility, it is difficult to prevent the occurrence of a conductive or capacitive path from the patient's body to some grounded object, because that path may be established accidentally or through instrumentation directly connected to the patient. Other electrically conductive surfaces which may make an additional contact with the patient, or instruments which may be connected to the patient, then become possible sources of electric currents which can traverse the patient's body. The hazard is increased as more apparatus is associated with the patient, and therefore more intensive precautions must be taken. Control of electric shock hazard requires the limitation of electric current that might flow in an electric circuit involving the patient's body, by raising the resistance of the conductive circuit which includes the patient, or by insulating exposed surfaces which might become energized, in addition to reducing the potential difference which can appear between exposed conductive surfaces in the patient vicinity, or by combinations of these methods. A special problem is presented by the patient with an externalized direct conductive path to the heart muscle. The patient may be electrocuted at current levels so low that additional protection in the design of appliances, insulation of the catheter, and control of medical practice are required.

(b)\* **Patient Care Areas.** Areas of a health care facility in which patient care is administered are classified as general care areas, critical care areas, and wet locations. The governing body of the facility shall designate these areas in accordance with the type of patient care anticipated, and with the following definitions of the three types of areas.

(1) General care areas are patient bedrooms, examining rooms, treatment rooms, clinics, and similar areas in which it is intended that the patient shall come in contact with ordinary appliances such as a nurse call system, electrical beds, examining lamps, telephone, and entertainment devices. In such areas, it may also be intended that patients be connected to electromedical devices (such as heating pads, electrocardiographs, drainage pumps, monitors, otoscopes, ophthalmoscopes, peripheral intravenous lines).

(2) Critical care areas are those special care units, intensive care units, coronary care units, angiography laboratories, cardiac catheterization laboratories, delivery rooms, operating rooms, and similar areas in which patients are intended to be subjected to invasive procedures and connected to line-operated, electromedical devices.

(3) A wet location is a patient care area that is normally subject to wet conditions including standing water on the floor or routine dousing or drenching of the work area. Routine housekeeping procedures and incidental spillage of liquids do not define a wet location.

#### 517-81. Grounding.

(a) **Methods.** In addition to the requirements of Section 517-11, all branch circuits serving patient care areas shall be provided with a ground path for fault current by installation in rigid metal conduit, intermediate metal

conduit, electrical metallic tubing, Type MI cable, Type MC cable, or Type AC cable where the outer metal jacket is an approved grounding means. Integrity of this ground path shall be verified.

(b) **Performance.** Any two exposed conductive surfaces in the patient vicinity shall not exceed the following potential differences at frequencies of 1000 hertz or less measured across a 1000-ohm resistance.

(1) **General Care Areas.** 500 mV under normal operation.

(2) **Critical Care Areas.** 40 mV under normal operation.

**517-82. Panelboard Bonding.** The equipment grounding terminal bars of the normal and essential electrical system panelboards shall be bonded together with an insulated continuous copper conductor not smaller than No. 10.

**517-83. General Care Areas.**

(a) **Patient Bed Location Branch Circuits.** Each patient bed location where inpatient care is provided shall be supplied by at least two branch circuits, at least one of which originated in a normal system panelboard; all branch circuits from the normal system shall originate in the same panelboard.

*Exception No. 1: Branch circuits serving only special-purpose outlets or receptacles, such as portable X-ray outlets, need not be served from the same distribution panel or panels.*

*Exception No. 2: Clinics, medical and dental offices, and outpatient facilities; psychiatric, substance abuse, and rehabilitation hospitals; nursing homes and residential custodial care facilities meeting the requirements of the Exception to Section 517-40.*

(b) **Patient Bed Location Receptacles.** Each patient bed location shall be provided with a minimum of four single or two duplex receptacles; each receptacle shall be grounded by means of an insulated copper conductor sized in accordance with Table 250-95.

*Exception No. 1: Psychiatric, substance abuse, and rehabilitation hospitals meeting the requirements of the Exception to Section 517-40.*

*Exception No. 2: Psychiatric security rooms shall not be required to have receptacle outlets installed in the room.*

**517-84. Critical Care Areas.**

(a) **Patient Bed Location Branch Circuits.** Each patient bed location shall be supplied by at least two branch circuits, one or more from the emergency system and one or more circuits from the normal system. At least one branch circuit from the emergency system shall supply an outlet(s) only at that bed location. All branch circuits from the normal system shall be from a single panelboard; all branch circuits from the emergency system shall be from a single panelboard. Emergency system receptacles shall be identified, and shall also indicate the panelboard and circuit number supplying them.

*Exception: Branch circuits serving only special-purpose receptacles or equipment in critical care areas shall be permitted to be served by other panelboards.*

(b) **Patient Bed Location Receptacles.** Each patient bed location shall be provided with a minimum of six single or three duplex receptacles listed

“Hospital Grade” and so identified; each receptacle shall be grounded to the reference grounding point by means of an insulated copper equipment grounding conductor.

**(c) Grounding and Bonding, Patient Vicinity.**

(1) A patient bed location shall be permitted to have a patient equipment grounding point, grounded to the reference grounding point by means of an insulated continuous copper conductor, not smaller than No. 10, running directly to the reference grounding point or by means of a conductor permanently connected to the grounding conductor of a nearby power receptacle. The patient equipment grounding point, where supplied, shall be permitted to contain one or more jacks listed for the purpose.

(2) Fixed exposed conductive surfaces in the patient vicinity likely to become energized shall be connected to the room bonding point(s) or the reference grounding point by continuous copper conductors, or conductive building structural members having conductance at least equal to AWG No. 10 copper wire. The bonding conductors, if installed, shall be permitted to be arranged centrally or looped as convenient.

*Exception: Small wall-mounted conductive surfaces not likely to become energized, such as surface-mounted towel and soap dispensers, mirrors, and so forth, need not be connected to the room bonding point. Similarly, large metal surfaces not likely to become energized (such as window and door frames) need not be intentionally grounded by connection to the room bonding point.*

(3) The requirements in Section 517-84(c)(2) shall not apply to bedside stands, over-bed tables, chairs, portable IV poles, and small portable nonelectrical devices such as trays, pitchers, bedpans and the like. The requirements in Section 517-84(c)(2) shall not apply to portable appliances or furniture.

(4) Any of the grounding and bonding points in Section 517-84(c)(1) and (c)(2) shall be permitted to be combined into a single point.

**(d) Panelboard Grounding.** When a grounded electrical distribution system is used, and metallic feeder raceway or Type MC or MI cables are installed, grounding of a panelboard or switchboard shall be assured by one of the following means at each termination or junction point of the raceway or Type MC or MI cable:

(1) A grounding bushing and a continuous copper bonding jumper, sized in accordance with Section 250-95, where a locknut-bushing connection is provided.

(2) Connection of feeder raceways or Type MC or MI cables to threaded hubs or bosses on terminating enclosures.

(3) Other approved devices, such as bonding-type locknuts or bushings.

**(e) Isolated Power System Grounding.** Where an isolated ungrounded power source is used and limits the first-fault current to a low magnitude, the grounding conductor associated with the secondary circuit shall be permitted to be run outside of the enclosure of the power conductors in the same circuit.

(FPN): Although it is permitted to run the grounding conductor outside of the conduit, it is safer to run it with the power conductors to provide better protection in case of a second ground fault.

(f) **Special Purpose Receptacle Grounding.** The equipment grounding conductor for special purpose receptacles such as the operation of mobile X-ray equipment shall be extended to the reference grounding points of branch circuits for all locations likely to be served from such receptacles. When such a circuit is served from an isolated ungrounded system, the grounding conductor need not be run with the power conductors; however, the equipment grounding terminal of the special purpose receptacle shall be connected to the reference grounding point.

#### 517-90. Additional Protective Techniques.

##### (a) Critical Care Areas.

(1) Isolated power systems shall be permitted to be used for critical care areas.

(2) Isolated power system equipment shall be listed for the purpose and the system so designed and installed that it meets the provisions and is in accordance with Section 517-104.

*Exception: The audible and visual indicators of the line isolation monitor shall be permitted to be located at the nursing station for the area being served.*

(b) **Pediatric and Psychiatric Locations.** Fifteen- and 20-ampere, 125-volt receptacles intended to supply patient care areas of pediatric or psychiatric wards, rooms, or areas shall be tamperproof. For the purpose of this section, a tamperproof receptacle is a receptacle which by its construction limits improper access to its energized contacts.

(c) **Wet Locations.** Fifteen- and 20-ampere, 125-volt, single-phase receptacles supplying wet locations shall be provided with ground-fault circuit-interrupters if interruption of power under fault conditions can be tolerated, or an isolated power system if such interruption cannot be tolerated.

(FPN): For requirements for installation of therapeutic pools and tubs, see Part F of Article 680.

#### G. Inhalation Anesthetizing Locations

(FPN): For further information regarding safeguards for anesthetizing locations, see Health Care Facilities, NFPA 99-1984, Chapters 3 and 4 (ANSI).

#### 517-100. Anesthetizing Location Classifications.

##### (a) Hazardous (Classified) Location.

(1)\* In a location where flammable anesthetics are employed, the entire area shall be considered to be a Class I, Division 1 location which shall extend upward to a level 5 feet (1.52 m) above the floor. The remaining volume up to the structural ceiling is considered to be above a hazardous (classified) location.

(2) Any room or location in which flammable anesthetics or volatile flammable disinfecting agents are stored shall be considered to be a Class I, Division 1 location from floor to ceiling.

(b) **Other-than-Hazardous (Classified) Location.** Any inhalation anesthetizing location designated for the exclusive use of nonflammable anesthetizing agents shall be considered to be an other-than-hazardous (classified) location.

**517-101. Wiring and Equipment.****(a) Within Hazardous Anesthetizing Locations.**

(1)\* In hazardous (classified) location(s) referred to in Section 517-100, all fixed wiring and equipment, and all portable equipment, including lamps and other utilization equipment, operating at more than 10 volts between conductors shall comply with the requirements of Sections 501-1 through 501-15 and Section 501-16(a) and (b) for Class I, Division 1 locations. All such equipment shall be specifically approved for the hazardous atmospheres involved.

(2) Where a box, fitting, or enclosure is partially, but not entirely, within a hazardous (classified) location(s), the hazardous (classified) location(s) shall be considered to be extended to include the entire box, fitting, or enclosure.

(3) Receptacles and attachment plugs in hazardous (classified) location(s) shall be listed for use in Class I, Group C hazardous (classified) locations, and shall have provision for the connection of a grounding conductor.

(4) Flexible cords used in hazardous areas for connection to portable utilization equipment, including lamps operating at more than 8 volts between conductors, shall be of a type approved for extra-hard usage in accordance with Table 400-4, and shall include an additional conductor for grounding.

(5) A storage device for the flexible cord shall be provided, and shall not subject the cord to bending at a radius of less than 3 inches (76 mm).

**(b) Above Hazardous Anesthetizing Locations.**

(1) Wiring above a hazardous area referred to in Section 517-100 shall be installed in rigid metal conduit, electrical metallic tubing, intermediate metal conduit, Type MI cable, or Type MC cable which employs a continuous, gas/vapor-tight metallic sheath.

(2) Installed equipment which may produce arcs, sparks, or particles of hot metal, such as lamps and lampholders for fixed lighting, cutouts, switches, generators, motors, or other equipment having make-and-break or sliding contacts, shall be of the totally enclosed type or so constructed as to prevent escape of sparks or hot metal particles.

*Exception: Wall-mounted receptacles installed above the hazardous area in flammable anesthetizing locations shall not be required to be totally enclosed or have openings guarded or screened to prevent dispersion of particles.*

(3) Surgical and other lighting fixtures shall conform to Section 501-9(b).

*Exception No. 1: The surface temperature limitations set forth in Section 501-9(b)(2) shall not apply.*

*Exception No. 2: Integral or pendant switches which are located above and cannot be lowered into the hazardous (classified) location(s) shall not be required to be explosionproof.*

(4) Approved seals shall be provided in conformance with Section 501-5, and Section 501-5(a)(4) shall apply to horizontal as well as to vertical boundaries of the defined hazardous (classified) locations.

*Exception: Seals shall be permitted within 18 inches (457 mm) of the point at which a conduit emerges from a wall forming the boundary of an anesthetizing location if all of the following conditions are met:*

a. The junction box, switch or receptacle contains a seal-off device between the arcing contacts and the conduit.

b. The conduit is continuous (without coupling or fitting) between the junction box and the sealing fitting within 18 inches (457 mm) of the point where the conduit emerges from the wall.

(5) Receptacles and attachment plugs located above hazardous anesthetizing locations shall be listed for hospital use for services of prescribed voltage, frequency, rating, and number of conductors with provision for the connection of the grounding conductor. This requirement shall apply to attachment plugs and receptacles of the 2-pole, 3-wire grounding type for single-phase 120-volt, nominal, ac service.

(6) Plugs and receptacles for connection of 250-volt, 50-ampere and 60-ampere ac medical equipment for use above hazardous (classified) locations shall be so arranged that the 60-ampere receptacle will accept either the 50-ampere or the 60-ampere plug. Fifty-ampere receptacles shall be designed so as not to accept the 60-ampere attachment plug. The plugs shall be of the 2-pole, 3-wire design with a third contact connecting to the insulated (green or green with yellow stripe) equipment grounding conductor of the electrical system.

#### (c) Other-than-Hazardous Anesthetizing Locations.

(1) Wiring serving other-than-hazardous (classified) locations as defined in Section 517-100 shall be installed in rigid metal conduit, intermediate metal conduit, or electrical metallic tubing or shall be in Type MI cable, Type MC cable, or Type AC cable with an insulated equipment grounding conductor.

*Exception: Pendant receptacle constructions employing at least SJO or equivalent flexible cords suspended not less than 6 feet (1.83 m) from the floor.*

(2) Receptacles and attachment plugs installed and used in other-than-hazardous (classified) locations shall be listed for hospital use for services of prescribed voltage, frequency, rating, and number of conductors with provision for connection of the grounding conductor. This requirement shall apply to attachment plugs and receptacles of the 2-pole, 3-wire grounding type for single-phase 120-, 208-, or 240-volt, nominal, ac service.

(3) Plugs and receptacles for connection of 250-volt, 50-ampere, and 60-ampere ac medical equipment for use in other-than-hazardous (classified) locations shall be so arranged that the 60-ampere receptacle will accept either the 50-ampere or the 60-ampere plug. The 50-ampere receptacle shall be designed so as not to accept the 60-ampere attachment plug. The plug shall be of the 2-pole, 3-wire design with a third contact connecting to the insulated (green or green with yellow stripe) equipment grounding conductor of the electrical system.

**517-103<sup>x</sup>. Grounding.** In any anesthetizing area, all metallic raceways and metal-sheathed cables, and all noncurrent-carrying conductive portions of fixed or portable electric equipment shall be grounded.

*Exception: Equipment operating at not more than 10 volts between conductors shall not be required to be grounded.*

**517-104. Circuits in Anesthetizing Locations.****(a) Isolated Power Systems.**

(1)<sup>x</sup> Except as permitted in Section 517-104(c), each power circuit within, or partially within, a flammable anesthetizing location as referred to in Section 517-100 shall be isolated from any distribution system supplying other-than-flammable anesthetizing locations. Each isolated power circuit shall be controlled by a switch having a disconnecting pole in each isolated circuit conductor. Such isolation shall be accomplished by means of one or more transformers having no electrical connection between primary and secondary windings, by means of motor generator sets, or by means of suitably isolated batteries.

(2) Circuits supplying primaries of isolating transformers shall operate at not more than 600 volts between conductors and shall be provided with proper overcurrent protection. The secondary voltage of such transformers shall not exceed 600 volts between conductors of each circuit. All circuits supplied from such secondaries shall be ungrounded, and shall have an approved overcurrent device of proper ratings in each conductor. Circuits supplied directly from batteries or from motor generator sets shall be ungrounded, and shall be protected against overcurrent in the same manner as transformer-fed secondary circuits. If an electrostatic shield is present, it shall be connected to the reference grounding point.

(3) The isolating transformers, motor generator sets, or batteries and battery chargers, together with their primary and/or secondary overcurrent devices, shall not be installed in hazardous (classified) locations. The isolated secondary circuit wiring extending into a hazardous anesthetizing location shall be installed in accordance with Section 501-4.

(4) An isolated branch circuit supplying an anesthetizing location shall supply no other location. The insulation of the branch-circuit conductors on the secondary side of the isolated power supply shall have a dielectric constant of 3.5 or less. Wire pulling compounds that increase the dielectric constant shall not be used on the secondary conductors of the isolated power supply.

(5) The isolated circuit conductors shall be identified as follows:

Isolated Conductor No. 1 — Orange

Isolated Conductor No. 2 — Brown

For three-phase systems, the third conductor shall be identified as yellow.

**(b)<sup>x</sup> Line Isolation Monitor.**

(1) In addition to the usual control and overcurrent protective devices, each isolated power system shall be provided with a continually operating line isolation monitor that indicates possible leakage or fault currents from either isolated conductor to ground. The monitor shall be designed so that a green signal lamp, conspicuously visible to persons in the anesthetizing location, remains lighted when the system is adequately isolated from ground; an adjacent red signal lamp and an audible warning signal (remote if desired) shall be energized when the total hazard current (consisting of possible resistive and capacitive leakage currents) from either isolated conductor to ground reaches a threshold value of 5 milliamperes under nominal line voltage conditions. The line isolation monitor is not to alarm for a fault hazard current of less than 3.7 milliamperes. The line isolation monitor is not to alarm for a total hazard current of less than 5.0 milliamperes.



*Exception: A system shall be permitted to be designed to operate at a lower threshold value of total hazard current. A line isolation monitor for such a system shall be permitted to be approved with the provision that the fault hazard current shall be permitted to be reduced but not to less than 35 percent of the corresponding threshold value of the total hazard current, and the monitor hazard current is to be correspondingly reduced to no more than 50 percent of the alarm threshold value of the total hazard current.*

(FPN): Such systems contribute little additional electrical safety and are used for special applications.

(2) The line isolation monitor shall be designed to have sufficient internal impedance such that when properly connected to the isolated system the maximum internal current that can flow through the line isolation monitor, when any point of the isolated system is grounded, shall be 1 milliamperere.

*Exception: The line isolation monitor shall be permitted to be of the low impedance type such that the current through the line isolation monitor, when any point of the isolated system is grounded, will not exceed twice the alarm threshold value for a period not exceeding 5 milliseconds.*

(FPN): Reduction of the monitor hazard current, provided this reduction results in an increased "not alarm" threshold value for the fault hazard current, will increase circuit capacity.

(3) An ammeter calibrated in the total hazard current of the system (contribution of the fault hazard current plus monitor hazard current) shall be mounted in a plainly visible place on the line isolation monitor with the "alarm on" zone at approximately the center of the scale. It is desirable to locate the ammeter so that it is conspicuously visible to persons in the anesthetizing location.

*Exception: The line isolation monitor may be a composite unit, with a sensing section cabled to a separate display panel section on which the alarm and/or test functions are located.*

### (c) Grounded Power Systems.

(1) A general-purpose lighting circuit connected to the normal grounded service shall be installed in each operating room.

*Exception: Where connected to any alternate source permitted in Section 700-12 which is separate from the source serving the emergency system.*

(2) Branch circuits supplying only listed, fixed, therapeutic and diagnostic equipment, permanently installed above the hazardous (classified) location and in other-than-hazardous (classified) locations, shall be permitted to be supplied from a normal grounded service, single- or three-phase system, provided:

a. Wiring for grounded and isolated circuits does not occupy the same raceway,

b. All conductive surfaces of the equipment are grounded,

c. Equipment (except enclosed X-ray tubes and the leads to the tubes) are located at least 8 feet (2.44 m) above the floor or outside the anesthetizing location, and

d. Switches for the grounded branch circuit are located outside the hazardous (classified) location.

*Exception: Parts c. and d. shall not apply in other-than-hazardous (classified) locations.*

(3) Branch circuits supplying only fixed lighting shall be permitted to be supplied by a normal grounded service provided.

- a. Such fixtures are located at least 8 feet (2.44 m) above the floor,
- b. All conductive surfaces of fixtures are grounded,
- c. Wiring for circuits supplying power to fixtures does not occupy the same raceway for circuits supplying isolated power, and
- d. Switches are wall-mounted and located above hazardous (classified) locations.

(4) Wall-mounted remote control stations for remote control switches operating at 24 volts or less shall be permitted to be installed in any anesthetizing location.

(5) An isolated power center listed for the purpose and its grounded primary feeder shall be permitted to be located in an anesthetizing location provided it is installed above a hazardous (classified) location, or in an other-than-hazardous (classified) location.

#### **517-105<sup>2</sup>. Low-Voltage Equipment and Instruments.**

(a) **Equipment Requirements.** Low-voltage equipment which is frequently in contact with the bodies of persons or has exposed current-carrying elements shall:

- (1) Operate on an electrical potential of 10 volts or less, or
- (2) Be approved as intrinsically safe or double-insulated equipment.
- (3) Be moisture-resistant.

(b) **Power Supplies.** Power shall be supplied to low-voltage equipment from:

(1) An individual portable isolating transformer (autotransformers shall not be used) connected to an isolated power circuit receptacle by means of an appropriate cord and attachment plug, or

(2) A common low-voltage isolating transformer installed in a nonhazardous location, or

(3) Individual dry-cell batteries, or

(4) Common batteries made up of storage cells located in a nonhazardous location.

(c) **Isolated Circuits.** Isolating-type transformers for supplying low-voltage circuits shall:

(1) Have approved means for insulating the secondary circuit from the primary circuit, and

(2) Have the core and case grounded.

(d) **Controls.** Resistance or impedance devices shall be permitted to control low-voltage equipment but shall not be used to limit the maximum available voltage to the equipment.

(e) **Battery-Powered Appliances.** Battery-powered appliances shall not be capable of being charged while in operation unless their charging circuitry incorporates an integral isolating-type transformer.

**(f) Receptacles or Attachment Plugs.** Any receptacle or attachment plug used on low-voltage circuits shall be of a type which does not permit interchangeable connection with circuits of higher voltage.

(FPN): Any interruption of the circuit, even circuits as low as 8 volts, either by any switch, or loose or defective connections anywhere in the circuit, may produce a spark sufficient to ignite flammable anesthetic agents. [See Section 3-2.5.2 of Health Care Facilities, NFPA 99-1984 (ANSI)].

#### **H. Communications, Signaling Systems, Data Systems, Fire Protective Signaling Systems, and Low-Voltage Systems**

**517-120. Patient Care Areas.** Equivalent insulation, isolation, and grounding to that required for the electrical distribution systems in patient care areas shall be provided for communications, signaling systems, data system circuits, fire protective signaling systems, and low-voltage systems.

(FPN): An acceptable alternate means of providing isolation for patient/nurse call systems is by the use of nonelectrified signaling, communication or control devices held by the patient, or within reach of the patient.

(FPN): For grounding requirements, see Section 250-95.

**517-121. Other-than-Patient-Care Areas.** See Articles 725, 760, and 800.

**517-122. Signal Transmission Between Appliances.**

**(a) General.** Permanently installed signal cabling from an appliance in a patient location to remote appliances shall employ a signal transmission system which prevents hazardous grounding interconnection of the appliances. See Section 517-81.

**(b) Common Signal Grounding Wire.** Common signal grounding wires (i.e., the chassis ground for single-ended transmission) shall be permitted to be used between appliances all located within the patient vicinity, provided the appliances are served from the same reference grounding point.

#### **K. X-ray Installations**

Nothing in this part shall be construed as specifying safeguards against the useful beam or stray X-ray radiation.

(FPN): Radiation safety and performance requirements of several classes of X-ray equipment are regulated under Public Law 90-602 and are enforced by the Department of Health and Human Services.

(FPN): In addition, information on radiation protection by the National Council on Radiation Protection and Measurements is published as Reports of the National Council on Radiation Protection and Measurement. These reports are obtainable from NCRP Publications, P. O. Box 30175, Washington, D.C. 20014.

**517-140. Definitions.**

**Long-Time Rating.** A rating based on an operating interval of 5 minutes or longer.

**Mobile.** X-ray equipment mounted on a permanent base with wheels and/or casters for moving while completely assembled.

**Momentary Rating.** A rating based on an operating interval that does not exceed 5 seconds.

**Portable.** X-ray equipment designed to be hand carried.

**Transportable.** X-ray equipment to be installed in a vehicle or that may be readily disassembled for transport in a vehicle.

**517-141. Connection to Supply Circuit.**

(a) **Fixed and Stationary Equipment.** Fixed and stationary X-ray equipment shall be connected to the power supply by means of a wiring method meeting the general requirements of this Code.

*Exception: Equipment properly supplied by a branch circuit rated at not over 30 amperes shall be permitted to be supplied through a suitable attachment plug and hard-service cable or cord.*

(b) **Portable, Mobile, and Transportable Equipment.** Individual branch circuits shall not be required for portable, mobile, and transportable medical X-ray equipment requiring a capacity of not over 60 amperes.

(c) **Over 600-Volt Supply.** Circuits and equipment operated on a supply circuit of over 600 volts shall comply with Article 710.

**517-142. Disconnecting Means.**

(a) **Capacity.** A disconnecting means of adequate capacity for at least 50 percent of the input required for the momentary rating or 100 percent of the input required for the long-time rating of the X-ray equipment, whichever is greater, shall be provided in the supply circuit.

(b) **Location.** The disconnecting means shall be operable from a location readily accessible from the X-ray control.

(c) **Portable Equipment.** For equipment connected to a 120-volt branch circuit of 30 amperes or less, a grounding-type attachment plug and receptacle of proper rating shall be permitted to serve as a disconnecting means.

**517-143. Rating of Supply Conductors and Overcurrent Protection.**

(a) **Diagnostic Equipment.**

(1) The ampacity of supply branch-circuit conductors and the current rating of overcurrent protective devices shall not be less than 50 percent of the momentary rating or 100 percent of the long-time rating whichever is greater.

(2) The ampacity of supply feeder and the current rating of overcurrent protective devices supplying two or more branch circuits supplying X-ray units shall not be less than 50 percent of the momentary demand rating of each of the two largest diagnostic X-ray units plus 20 percent of the momentary ratings of each of the additional diagnostic X-ray units. Where simultaneous byplane examinations are undertaken with the X-ray units the supply conductors and overcurrent protective devices shall be 100 percent of the momentary rating of each X-ray unit.

(FPN): The minimum conductor size for branch and feeder circuits is also governed by voltage regulation requirements. For a specific installation, the manufacturer usually specifies: minimum distribution transformer and conductor sizes, rating of disconnecting means, and overcurrent protection.

(b) **Therapeutic Equipment.** The ampacity of conductors and rating of overcurrent protective devices shall not be less than 100 percent of the current rating of medical X-ray therapy equipment.

(FPN): The ampacity of the branch-circuit conductors and the ratings of disconnecting means and overcurrent protection for X-ray equipment are usually designated by the manufacturer for the specific installation.

#### **517-145. Control Circuit Conductors.**

(a) **Number of Conductors in Raceway.** The number of control circuit conductors installed in a raceway shall be determined in accordance with Section 300-17.

(b) **Minimum Size of Conductors.** Sizes No. 18 or No. 16 fixture wires as specified in Section 725-16 and flexible cords shall be permitted for the control and operating circuits of X-ray and auxiliary equipment where protected by not larger than 20-ampere overcurrent devices.

**517-146. Equipment Installations.** All equipment for new X-ray installations and all used or reconditioned X-ray equipment moved to and reinstalled at a new location shall be of an approved type.

**517-148. Transformers and Capacitors.** Transformers and capacitors that are part of an X-ray equipment shall not be required to comply with Articles 450 and 460.

Capacitors shall be mounted within enclosures of insulating material or grounded metal.

#### **517-151. Guarding and Grounding.**

(a) **High-Voltage Parts.** All high-voltage parts, including X-ray tubes, shall be mounted within grounded enclosures. Air, oil, gas, or other suitable insulating media shall be used to insulate the high voltage from the grounded enclosure. The connection from the high-voltage equipment to X-ray tubes and other high-voltage components shall be made with high-voltage shielded cables.

(b) **Low-Voltage Cables.** Low-voltage cables connecting to oil-filled units that are not completely sealed, such as transformers, condensers, oil coolers, and high-voltage switches, shall have insulation of the oil-resistant type.

(c) **Noncurrent-Carrying Metal Parts.** Noncurrent-carrying metal parts of X-ray and associated equipment (controls, tables, X-ray tube supports, transformer tanks, shielded cables, X-ray tube heads, etc.) shall be grounded in the manner specified in Article 250, as modified by Section 517-11 under the criteria set forth in Section 517-81 for critical care areas.

*Exception: Battery-operated equipment.*

## **ARTICLE 518 — PLACES OF ASSEMBLY**

**518-1. Scope.** This article covers all buildings or portions of buildings or structures designed or intended for the assembly of 100 or more persons.

**518-2. General Classifications:** Places of Assembly shall include, but are not limited to:

Assembly Halls  
Armories  
Restaurants

Exhibition Halls  
Dining Facilities  
Church Chapels

Dance Halls	Mortuary Chapels
Museums	Skating Rinks
Gymnasiums	Multipurpose Rooms
Bowling Lanes	Pool Rooms
Club Rooms	Places of Awaiting
Court Rooms	Transportation
Conference Rooms	Auditoriums
Auditoriums within:	
Schools	
Mercantile Establishments	
Business Establishments	
Other Occupancies.	

Occupancy of any room or space for assembly purposes by less than 100 persons in a building of other occupancy, and incidental to such other occupancy, shall be classed as part of the other occupancy and subject to the provisions applicable thereto.

Where any such building structure, or portion thereof, contains a projection booth or stage platform or area for the presentation of theatrical or musical productions, either fixed or portable, the wiring for that area and all equipment that is used in the referenced area, and portable equipment and wiring for use in the production that will not be connected to permanently installed wiring shall comply with Article 520.

(FPN): For methods of determining population capacity, see local building code or in its absence Life Safety Code, NFPA 101-1985 (ANSI).

### 518-3. Other Articles.

(a) **Hazardous (Classified) Areas.** Hazardous (classified) areas located in any assemblage occupancy shall be installed in accordance with Article 500 — Hazardous (Classified) Locations.

(b) **Temporary Wiring.** In exhibition halls used for display booths, as in trade shows, the temporary wiring shall be installed in accordance with Article 305 — Temporary Wiring, except that approved flexible cables and cords shall be permitted to be laid on floors where protected from contact by the general public.

(c) **Emergency Systems.** Control of emergency systems shall comply with Article 700 — Emergency Systems.

**518-4. Wiring Methods.** The fixed wiring methods shall be metal raceways, nonmetallic raceways encased in not less than 2 inches (50.8 mm) of concrete, Type MI cable, or Type MC cable.

*Exception No. 1: Nonmetallic-sheathed cable, Type AC cable, and rigid nonmetallic conduit shall be permitted to be installed in those buildings or portions thereof that are not required to be fire-rated construction by the applicable building code.*

*Exception No. 2: As provided in Article 640 — Sound Reproduction and Similar Equipment, in Article 800 — Communication Circuits, and in Article 725 for Class 2 and Class 3 remote-control and signaling circuits, and in Article 760 for fire protective signaling circuits.*

(FPN): Fire-rated construction is the fire-resistive classification used in building codes.

## ARTICLE 520 — THEATERS AND SIMILAR LOCATIONS

### A. General

**520-1. Scope.** This article covers all buildings or that part of a building or structure designed or intended to be used for dramatic, musical, motion picture projection, or similar purposes and to areas of motion picture and television studios which incorporate assembly areas.

**520-2. Motion Picture Projectors.** Motion picture equipment and its installation and use shall comply with Article 540.

**520-3. Sound Reproduction.** Sound-reproducing equipment and its installation shall comply with Article 640.

**520-4. Wiring Methods.** The fixed wiring method shall be metal raceways, nonmetallic raceways encased in at least 2 inches (50.8 mm) of concrete, Type MI cable, or Type MC cable.

*Exception No. 1: As provided in Article 640 for sound reproduction, in Article 800 for communication circuits, in Article 725 for Class 2 and Class 3 remote-control and signaling circuits, and in Article 760 for fire protective signaling circuits.*

*Exception No. 2: The wiring for portable switchboards, stage set lighting, stage effects, and other wiring not fixed as to location shall be permitted with approved flexible cords and cables as provided elsewhere in Article 520. Fastening such cables and cords by uninsulated staples or nailing shall not be permitted.*

**520-5. Number of Conductors in Raceway.** The number of conductors permitted in any metal conduit, rigid nonmetallic conduit as permitted in this article, or electrical metallic tubing for border or stage pocket circuits or for remote-control conductors shall not exceed the percentage fill shown in Table 1 of Chapter 9. Where contained within an auxiliary gutter or a wireway, the sum of the cross-sectional areas of all contained conductors at any cross section shall not exceed 20 percent of the interior cross-sectional area of the auxiliary gutter or wireway. The thirty-conductor limitation of Sections 362-5 and 374-5 shall not apply.

**520-6. Enclosing and Guarding Live Parts.** Live parts shall be enclosed or guarded to prevent accidental contact by persons and objects. All switches shall be of the externally operable type. Dimmers, including rheostats, shall be placed in cases or cabinets that enclose all live parts.

**520-7. Emergency Systems.** Control of emergency systems shall comply with Article 700 — Emergency Systems.

### B. Fixed Stage Switchboard

**520-21. Dead Front.** Stage switchboards shall be of the dead-front type and shall comply with Part C of Article 384 unless approved based on suitability as a stage switchboard as determined by a qualified testing laboratory and recognized test standards and principles.

**520-22. Guarding Back of Switchboard.** Stage switchboards having exposed live parts on the back of such boards shall be enclosed by the building walls, wire mesh grills, or by other approved methods. The entrance to this enclosure shall be by means of a self-closing door.

**520-23. Control and Overcurrent Protection of Receptacle Circuits.** Means shall be provided at a stage lighting switchboard to which load circuits are connected for individual overcurrent protection of stage lighting branch circuits and stage and gallery receptacles used for cord- and plug-connected stage equipment. Where the stage switchboard contains dimmers to control nonstage lighting, the locating of the overcurrent protective devices for these branch circuits at the stage switchboard shall be permitted.

**520-24. Metal Hood.** A stage switchboard that is not completely enclosed dead-front and dead-rear or recessed into a wall shall be provided with a metal hood extending the full length of the board to protect all equipment on the board from falling objects.

**520-25. Dimmers.** Dimmers shall comply with (a) through (d) below.

(a) **Disconnection and Overcurrent Protection.** Where dimmers are installed in ungrounded conductors, each dimmer shall have overcurrent protection not greater than 125 percent of the dimmer rating, and shall be disconnected from all ungrounded conductors when the master or individual switch or circuit breaker supplying such dimmer is in the open position.

(b) **Resistance- or Reactor-type Dimmers.** Resistance- or series reactor-type dimmers shall be permitted to be placed in either the grounded or the ungrounded conductor of the circuit. Where designed to open either the supply circuit to the dimmer or the circuit controlled by it, the dimmer shall then comply with Section 380-1. Resistance- or reactor-type dimmers placed in the grounded neutral conductor of the circuit shall not open the circuit.

(c) **Autotransformer-type Dimmers.** The circuit supplying an autotransformer-type dimmer shall not exceed 150 volts between conductors. The grounded conductor shall be common to the input and output circuits.

(d) **Solid-State-type Dimmers.** The circuit supplying a solid-state dimmer shall not exceed 150 volts between conductors unless the dimmer is specifically approved for higher voltage operation. When a grounded conductor supplies a dimmer, it shall be common to the input and output circuits. Dimmer chassis shall be connected to the equipment grounding conductor.

(FPN): See Section 210-9 for circuits derived from autotransformers.

**520-26. Type of Switchboard.** Stage switchboard shall be either one or a combination of the following types:

(a) **Manual.** Dimmers and switches are operated by handles mechanically linked to the control devices.

(b) **Remotely Controlled.** Devices are operated electrically from a pilot-type control console or panel. Pilot control panels shall either be part of the switchboard or shall be permitted to be at another location.

(c) **Intermediate.** A stage switchboard with circuit interconnections is a secondary switchboard (patch panel) or panelboard remote to the primary stage switchboard. It shall contain overcurrent protection. Where the required branch circuit overcurrent protection is provided in the dimmer panel, it shall be permitted to be omitted from the intermediate switchboard.



**520-27. Stage Switchboard Feeders.** Feeders supplying stage switchboards shall be one of the following:

(a) **Single Feeder.** A single feeder disconnected by a single disconnect device.

(b) **Multiple Feeders to Intermediate Stage Switchboard (Patch Panel).** Multiple feeders of unlimited quantity shall be permitted, provided that all multiple feeders are part of a single system. When combined, neutral conductors in a given raceway shall be of sufficient ampacity to carry the maximum unbalanced current supplied by multiple feeder conductors in the same raceway, but need not be greater than the ampacity of the neutral supplying the primary stage switchboard. Parallel neutral conductors shall comply with Section 310-4. The neutral of feeders supplying solid-state, 3-phase; 4-wire dimming systems shall be considered a current-carrying conductor.

(c) **Separate Feeders to Single Primary Stage Switchboard (Dimmer Bank).** Installations with separate feeders to a single primary stage switchboard shall have a disconnecting means for each feeder. The primary stage switchboard shall have a permanent and obvious label stating the number and location of disconnecting means. If the disconnecting means are located in more than one distribution switchboard, the primary stage switchboard shall be provided with barriers to correspond with these multiple locations.

### C. Stage Equipment — Fixed

**520-41. Circuit Loads.** Footlights, border lights, and proscenium side lights shall be so arranged that no branch circuit supplying such equipment will carry a load exceeding 20 amperes.

*Exception: Where heavy-duty lampholders only are used, such circuits shall be permitted to comply with Article 210 for circuits supplying heavy-duty lampholders.*

**520-42. Conductor Insulation.** Foot, border, proscenium, or portable strip light fixtures and connector strips shall be wired with conductors having insulation suitable for the temperatures at which the conductors will be operated and not less than 125°C (257°F).

(FPN): See Table 310-13 for conductor types.

**520-43. Footlights.**

(a) **Metal Trough Construction.** Where metal trough construction is employed for footlights, the trough containing the circuit conductors shall be made of sheet metal not lighter than No. 20 MSG treated to prevent oxidation. Lampholder terminals shall be kept at least ½ inch (12.7 mm) from the metal of the trough. The circuit conductors shall be soldered to the lampholder terminals.

(b) **Other-than-Metal-Trough Construction.** Where the metal trough construction specified in Section 520-43(a) is not used, footlights shall consist of individual outlets with lampholders, wired with rigid metal conduit, intermediate metal conduit, or flexible metal conduit, Type MC cable, or mineral-insulated, metal-sheathed cable. The circuit conductors shall be soldered to the lampholder terminals. Disappearing footlights shall be so arranged that

the current supply will be automatically disconnected when the footlights are replaced in the recess designed for them.

**520-44. Borders and Proscenium Sidelights.**

(a) **General.** Borders and proscenium sidelights shall be: (1) constructed as specified in Section 520-43; (2) suitably stayed and supported; and (3) so designed that the flanges of the reflectors or other adequate guards will protect the lamps from mechanical injury and from accidental contact with scenery or other combustible material.

(b) **Cables for Border Lights.** Cables for supply to border lights shall be Type G, S, SO, ST, STO, or W flexible cable as provided in Table 400-4. The cables shall be suitably supported. Such cables shall be employed only where flexible conductors are necessary.

**520-45. Receptacles.** Receptacles for electrical equipment or fixtures on stages shall be rated in amperes.

(1) A continuous load shall not exceed 80 percent of the receptacle rating.

(2) A noncontinuous load shall not exceed 100 percent of the receptacle rating.

Conductors supplying receptacles shall be in accordance with Article 310.

**520-46. Connector Strips, Drop Boxes, and Stage Pockets.** Receptacles for the connection of portable stage lighting equipment shall be pendant or mounted in suitable pockets or enclosures and comply with Section 520-45.

**520-47. Lamps in Scene Docks.** Lamps installed in scene docks shall be so located and guarded as to be free from physical damage and shall provide an air space of not less than 2 inches (50.8 mm) between such lamps and any combustible material.

**520-48. Curtain Motors.** Curtain motors having brushes or sliding contacts shall comply with one of the conditions in (a) through (f) below.

(a) **Types.** Be of the totally enclosed, enclosed-fan-cooled, or enclosed-pipe-ventilated type.

(b) **Separate Rooms or Housings.** Be enclosed in separate rooms or housings built of noncombustible material so constructed as to exclude flyings or lint, and properly ventilated from a source of clean air.

(c) **Solid Metal Covers.** Have the brush or sliding-contact end of motor enclosed by solid metal covers.

(d) **Tight Metal Housings.** Have brushes or sliding contacts enclosed in substantial, tight metal housings.

(e) **Upper and Lower Half Enclosures.** Have the upper half of the brush or sliding-contact end of the motor enclosed by a wire screen or perforated metal and the lower half enclosed by solid metal covers.

(f) **Wire Screens or Perforated Metal.** Have wire screens or perforated metal placed at the commutator of brush ends. No dimension of any opening in the wire screen or perforated metal shall exceed .05 inch (1.27 mm), regardless of the shape of the opening and of the material used.

**520-49. Flue Damper Control.** Where stage flue dampers are released by an electrical device, the circuit operating the device shall be normally closed and

shall be controlled by at least two externally operable switches, one switch being placed at the electrician's station and the other where designated by the authority having jurisdiction. The device shall be designed for the full voltage of the circuit to which it is connected, no resistance being inserted. The device shall be located in the loft above the scenery and shall be enclosed in a suitable metal box having a tight, self-closing door.

#### D. Portable Switchboards on Stage

**520-50. Road-Show Connection Panel (A Type of Patch Panel).** A panel designed to allow for road show connection of portable stage switchboards to fixed lighting outlets by means of permanently installed supplementary circuits. The panel, supplementary circuits, and outlets shall comply with (a) through (d) below.

**(a) Load Circuits.** Circuits shall terminate in grounded polarized inlets of current and voltage rating which matches the fixed load receptacle.

**(b) Circuit Transfer.** Circuits which are transferred between fixed and portable switchboards shall have both the line and neutral transferred simultaneously.

**(c) Overcurrent Protection:** The supply devices of these supplementary circuits shall be protected by branch-circuit overcurrent protective devices. The individual supplementary circuit, within the road show connection panel and theatre, shall be protected by branch-circuit overcurrent protective devices of suitable ampacity installed within the road show connection panel.

**(d) Enclosure.** Panel construction shall be as per Article 384.

**520-51. Supply.** Portable switchboards shall be supplied only from outlets of sufficient voltage and ampere rating. Such outlets shall include only externally operable, enclosed fused switches or circuit breakers mounted on stage or at the permanent switchboard in locations readily accessible from the stage floor. Provisions for connection of an equipment grounding conductor shall be provided. The neutral of feeders supplying solid-state, 3-phase, 4-wire dimmer systems shall be considered a current-carrying conductor.

**520-52. Overcurrent Protection.** Circuits from portable switchboards directly supplying equipment containing incandescent lamps of not over 300 watts shall be protected by overcurrent protective devices having a rating or setting of not over 20 amperes. Circuits for lampholders over 300 watts shall be permitted where overcurrent protection complies with Article 210.

**520-53. Construction and Feeders.** Portable switchboards and feeders for use on stages shall comply with (a) through (n) below.

**(a) Enclosure.** Portable switchboards shall be placed within an enclosure of substantial construction, which shall be permitted to be so arranged that the enclosure is open during operation. Enclosures of wood shall be completely lined with sheet metal of not less than No. 24 MSG and shall be well galvanized, enameled, or otherwise properly coated to prevent corrosion or be of a corrosion-resistant material.

**(b) Live Parts.** There shall be no exposed live parts within the enclosure.

*Exception: For dimmer faceplates as provided in (e) below:*

(c) **Switches and Circuit Breakers.** All switches and circuit breakers shall be of the externally operable, enclosed type.

(d) **Circuit Protection.** Overcurrent devices shall be provided in each ungrounded conductor of every circuit supplied through the switchboard. Enclosures shall be provided for all overcurrent devices in addition to the switchboard enclosure.

(e) **Dimmers.** The terminals of dimmers shall be provided with enclosures, and dimmer faceplates shall be so arranged that accidental contact cannot be readily made with the faceplate contacts.

(f) **Interior Conductors.** All conductors other than busbars within the switchboard enclosure shall be stranded. Conductors shall be approved for an operating temperature at least equal to the approved operating temperature of the dimming devices used in the switchboard and in no case less than the following: (1) resistance-type dimmers: 200°C (392°F); or (2) reactor-type, autotransformer, and solid-state dimmers: 125°C (257°F). All control wiring shall comply with Article 725.

Each conductor shall have an ampacity at least equal to the rating of the circuit breaker, switch, or fuse which it supplies. Circuit interrupting and bus bracing shall be in accordance with Sections 110-9 and 110-10. Switchboards with inadequate short-circuit withstand rating shall be protected on the line side by current-limiting devices. The short-circuit withstand rating shall be marked on the switchboard.

*Exception: Conductors for pilot light circuits having overcurrent protection of not over 20 amperes.*

Conductors shall be enclosed in metal wireways or be securely fastened in position and shall be bushed where they pass through metal.

(g) **Pilot Light.** A pilot light shall be provided within the enclosure and shall be so connected to the circuit supplying the board that the opening of the master switch will not cut off the supply to the lamp. This lamp shall be on an individual branch circuit having overcurrent protection rated or set at not over 15 amperes.

(h) **Supply Conductors.** The supply to a portable switchboard shall be by means of Type S, SO, ST, or STO cords, or G or W cable. The supply cords or cable shall terminate within the switchboard enclosure, in an externally operable fused master switch or circuit breaker, or in a connector assembly identified for the purpose. The supply cords or cable (and connector assembly) shall have sufficient ampacity to carry the total load connected to the switchboard and shall be protected by overcurrent devices.

Single-conductor cables shall be minimum No. 1 AWG in size. The single-conductor cables for a supply shall be of the same length, type, size, and be grouped together, but not bundled. The equipment grounding conductor shall be permitted to be of a different type, provided it meets the other requirements of this section, and it shall be permitted to be reduced in size as permitted by Section 250-95. Neutral and equipment grounding conductors shall be identified as per Section 310-12.

*Exception No. 1: Supply Conductors Not Over 10 Feet (3.05 m) Long. In cases where supply conductors do not exceed 10 feet (3.05 m) in length between supply and switchboard or supply and a subsequent overcurrent device, the ampacity of the supply conductors shall be at least one-quarter of*

*the ampacity of the supply overcurrent protection device where all of the following conditions are met:*

*a. The supply conductors shall terminate in a single overcurrent protection device that will limit the load to the ampacity of the supply conductors. This single overcurrent device shall be permitted to supply additional overcurrent devices on its load side.*

*b. The supply conductors shall not penetrate walls, floors, or ceilings, or be run through doors or traffic areas. The supply conductors shall be adequately protected from physical damage.*

*c. The supply conductors shall be suitably terminated in an approved manner.*

*d. Conductors shall be continuous without splices or connectors.*

*e. Conductors shall not be bundled.*

*f. Conductors shall be supported above the floor in an approved manner.*

*Exception No. 2: Supply Conductors Not Over 20 Feet (6.1 m) Long. In cases where supply conductors do not exceed 20 feet (6.1 m) in length between supply and switchboard or supply and a subsequent overcurrent protection device, the ampacity of the supply conductors shall be at least one-half the rating of the supply overcurrent protection device where all of the following conditions are met:*

*a. The supply conductors shall terminate in a single overcurrent protection device that will limit the load to the ampacity of the supply conductors. This single overcurrent device shall be permitted to supply additional overcurrent devices on its load side.*

*b. The supply conductors shall not penetrate walls, floors, or ceilings, or be run through doors or traffic areas. The supply conductors shall be adequately protected from physical damage.*

*c. The supply conductors shall be suitably terminated in an approved manner.*

*d. The supply conductors shall be supported in an approved manner at least 7 feet (2.13 m) above the floor except at terminations.*

*e. The supply conductors shall not be bundled.*

*f. Tap conductors shall be in unbroken lengths.*

**(i) Cable Arrangement.** Cables shall be protected by bushings where they pass through enclosures and shall be so arranged that tension on the cable will not be transmitted to the connections. Where power conductors pass through metal, the requirements of Section 300-20 shall apply.

**(j) Number of Supply Interconnections.** Where connectors are used in a supply conductor, there shall be a maximum number of three interconnections (mated connector pairs) when the total length from supply to switchboard does not exceed 100 feet (30.5 m). In cases where the total length from supply to switchboard exceeds 100 feet (30.5 m), one additional interconnection shall be permitted for each additional 100 feet (30.5 m) of supply conductor.

**(k) Protection of Supply Conductors and Connectors.** All supply conductors and connectors shall be protected against physical damage by an approved means. This protection shall not be required to be raceways.

(l) **Flanged Surface Inlets.** Flanged surface inlets (recessed plugs) that are used to accept the power shall be rated in amperes.

(m) **Terminals.** Terminals to which stage cables are connected shall be so located as to permit convenient access to the terminals.

(n) **Supply Neutral Terminal.** In portable switchboard equipment designed for use with 3-phase, 4-wire with ground supply, the supply neutral terminal and its associated busbar and/or equivalent wiring shall have an ampacity equal to twice the ampacity of the largest ungrounded supply terminal. The power supply lines for portable switchboards shall be sized considering the neutral as a current-carrying conductor.

*Exception: Where portable switchboard equipment is specifically constructed to be internally converted in the field, in an approved manner, from use with a balanced 3-phase, 4-wire with ground supply to a balanced single-phase, 3-wire with ground supply, the supply neutral terminal and its associated busbar, equivalent wiring, or both shall have an ampacity equal to that of the largest ungrounded single-phase supply terminal.*

### E. Stage Equipment — Portable

**520-61. Arc Lamps.** Arc lamps shall be listed.

**520-62. Portable Plugging Boxes.** Portable plugging boxes shall comply with (a) through (e) below.

(a) **Enclosure.** The construction shall be such that no current-carrying part will be exposed.

(b) **Receptacles and Overcurrent Protection.** Receptacles shall comply with Section 520-45 and shall have branch-circuit overcurrent protection in the box. Fuses and circuit breakers shall be protected against physical damage. Cords or cables supplying pendant receptacles shall be Type S, SO, ST, or STO cords, or G or W cables.

(c) **Busbars and Terminals.** Busbars shall have an ampacity equal to the sum of the ampere ratings of all the circuits connected to the busbar. Lugs shall be provided for the connection of the master cable.

(d) **Flanged Surface Inlets.** Flanged surface inlets (recessed plugs) that are used to accept the power shall be rated in amperes.

(e) **Cable Arrangement.** Cables shall be adequately protected where they pass through enclosures and be so arranged that tension on the cable will not be transmitted to the terminations.

**520-63. Bracket Fixture Wiring.**

(a) **Bracket Wiring.** Brackets for use on scenery shall be wired internally, and the fixture stem shall be carried through to the back of the scenery where a bushing shall be placed on the end of the stem.

*Exception: Externally wired brackets or other fixtures shall be permitted where wired with cords designed for hard usage that extend through scenery and without joint or splice in canopy of fixture back and terminate in an approved-type stage connector located, where practical, within 18 inches (457 mm) of the fixture.*

(b) **Mounting.** Fixtures shall be securely fastened in place.

**520-64. Portable Strips.** Portable strips shall be constructed in accordance with the requirements for border lights and proscenium side lights in Section 520-44(a). The supply cable shall be protected by bushings where it passes through metal and shall be so arranged that tension on the cable will not be transmitted to the connections.

(FPN): See Section 520-42 for wiring of portable strips.

(FPN): See Section 520-68, Exception No. 2, for insulation types required on single conductors.

**520-65. Festoons.** Joints in festoon wiring shall be staggered. Lamps enclosed in lanterns or similar devices of combustible material shall be equipped with guards.

**520-66. Special Effects.** Electrical devices used for simulating lightning, waterfalls, and the like shall be so constructed and located that flames, sparks, or hot particles cannot come in contact with combustible material.

**520-67. Cable Connectors.** Cable connectors, male and female, for flexible conductors shall be constructed so that tension on the cord or cable will not be transmitted to the connections. The female half shall be attached to the load end of the power supply cord or cable. The connector shall be rated in amperes and designed so that differently rated devices cannot be connected together. AC multipole connectors shall be polarized and comply with Section 410-56(e) and Section 410-58.

(FPN): See Section 400-10 for pull at terminals.

**520-68. Conductors for Portables.** Flexible conductors used to supply portable stage equipment shall be Type S, SO, ST, STO, G, or W.

*Exception No. 1: Reinforced cord shall be permitted to supply stand lamps where the cord is not subject to severe physical damage and is protected by an overcurrent device rated at not over 20 amperes.*

*Exception No. 2: A special assembly of conductors in sleeving no longer than 3.3 feet (1.0 m) shall be permitted to be employed in lieu of flexible cord if the individual wires are stranded and rated over 125°C (257°F) and the outer sleeve is glass fiber with a wall thickness of at least 0.025 inches (635 micrometers).*

*Exception No. 3: Portable stage equipment requiring flexible supply conductors with a higher temperature rating where one end is permanently attached to the equipment shall be permitted to employ alternate suitable conductors as determined by a qualified testing laboratory and recognized test standards.*

**520-69. Adapters.** Adapters, two-fers, and other single and multiple circuit outlet devices shall comply with (a) and (b) below.

**(a) No Reduction in Current Rating.** Each receptacle and its corresponding cable shall have the same current and voltage rating as the plug supplying it. It shall not be utilized in a stage circuit with a greater current rating.

**(b) Connectors.** All connectors shall be wired in accordance with Sections 520-67 and 520-68.

### F. Dressing Rooms

**520-71. Pendant Lampholders.** Pendant lampholders shall not be installed in dressing rooms.

**520-72. Lamp Guards.** All exposed incandescent lamps in dressing rooms, where less than 8 feet (2.44 m) from the floor, shall be equipped with open-end guards riveted to the outlet box cover or otherwise sealed or locked in place.

**520-73. Switches Required.** All lights and receptacles in dressing rooms shall be controlled by wall switches installed in the dressing rooms. Each switch controlling receptacles shall be provided with a pilot light to indicate when the receptacles are energized.

### G. Grounding

**520-81. Grounding.** All metal raceways and metal-sheathed cables shall be grounded. The metal frames and enclosures of all equipment, including border lights and portable lighting fixtures, shall be grounded. Grounding, where employed, shall be in accordance with Article 250.

## ARTICLE 530 — MOTION PICTURE AND TELEVISION STUDIOS AND SIMILAR LOCATIONS

### A. General

**530-1. Scope.** The requirements of this article shall apply to television studios and motion picture studios using either film or electronic cameras, except as provided in Section 520-1, and exchanges, factories, laboratories, stages, or a portion of the building in which film or tape more than  $\frac{7}{8}$  inch (22 mm) in width is exposed, developed, printed, cut, edited, rewound, repaired, or stored.

(FPN): For methods of protecting against cellulose nitrate film hazards, see Standard for the Storage and Handling of Cellulose Nitrate Motion Picture Film, NFPA 40-1982.

### B. Stage or Set

**530-11. Permanent Wiring.** The permanent wiring shall be Type MC cable, Type MI cable, or in approved raceways.

*Exception: Communication circuits, and sound recording and reproducing equipment shall be permitted to be wired as permitted by Articles 640 and 800.*

**530-12. Portable Wiring.** The wiring for stage set lighting, stage effects, electric equipment used as stage properties, and other wiring not fixed as to location shall be done with approved flexible cords and cables. Splices or taps shall be permitted in flexible cords used to supply stage properties when such are made with approved devices and the circuit is protected at not more



than 20 amperes. Such cables and cords shall not be fastened by staples or nailing.

**530-13. Stage Lighting and Effects Control.** Switches used for studio stage set lighting and effects (on the stages and lots and on location) shall be of the externally operable type. Where contactors are used as the disconnecting means for fuses, an individual externally operable switch, such as a tumbler switch, for the control of each contactor shall be located at a distance of not more than 6 feet (1.83 m) from the contactor, in addition to remote-control switches.

*Exception: A single externally operable switch shall be permitted to simultaneously disconnect all the contactors on any one location board, where located at a distance of not more than 6 feet (1.83 m) from the location board.*

**530-14. Plugging Boxes.** Each receptacle of dc plugging boxes shall be rated at not less than 30 amperes.

**530-15. Enclosing and Guarding Live Parts.**

(a) **Live Parts.** Live parts shall be enclosed or guarded to prevent accidental contact by persons and objects.

(b) **Switches.** All switches shall be of the externally operable type.

(c) **Rheostats.** Rheostats shall be placed in approved cases or cabinets that enclose all live parts, having only the operating handles exposed.

(d) **Current-Carrying Parts.** Current-carrying parts of bull-switches, location boards, spiders, and plugging boxes shall be so enclosed, guarded, or located that persons cannot accidentally come into contact with them or bring conductive material into contact with them.

**530-16. Portable Lamps.** Portable lamps and work lights shall be equipped with flexible cords, composition or metal-sheathed porcelain sockets, and substantial guards.

*Exception: Portable lamps used as properties in a motion picture set or television stage set, on a studio stage or lot, or on location.*

**530-17. Portable Arc Lamps.** Portable arc lamps shall be substantially constructed. The arc shall be provided with an enclosure designed to retain sparks and carbons and to prevent persons or materials from coming into contact with the arc or bare live parts. The enclosures shall be ventilated. All switches shall be of the externally operable type.

**530-18. Overcurrent Protection — Short-Time Rating.\***

**General.** Automatic overcurrent protective devices (circuit breakers or fuses) for motion picture studio stage set lighting and the stage cables for such stage set lighting shall be as given in (a) through (e) below.

(FPN): Note: \*Special consideration is given to motion picture studios and similar locations because filming periods are of short duration of 20 minutes.

(a) **Stage Cables.** Stage cables for stage set lighting shall be protected by means of overcurrent devices set at not more than 400 percent of the ampacity given in applicable tables of Articles 310 and 400.

(b) **Feeders.** In buildings used primarily for motion picture production, the feeders from the substations to the stages shall be protected by means of

overcurrent devices (generally located in the substation) having suitable ampere rating. The overcurrent devices shall be permitted to be multipole or single-pole gang-operated. No pole or overcurrent device shall be required in the neutral conductor. The overcurrent device setting for each feeder shall not exceed 400 percent of the ampacity of the feeder, as given in applicable tables of Article 310. Short-term ratings shall not be permitted when equipment is operated for periods in excess of 20 minutes.

(c) **Location Boards.** Overcurrent protection (fuses or circuit breakers) shall be provided at the "location boards." Fuses in the "location boards" shall have an ampere rating of not over 400 percent of the ampacity of the cables between the "location boards" and the plugging boxes.

(d) **Plugging Boxes.** Cables and cords supplied through plugging boxes shall be of copper. Cables and cords smaller than No. 8 shall be attached to the plugging box by means of a plug containing two cartridge fuses or a 2-pole circuit breaker. The rating of the fuses or the setting of the circuit breaker shall not be over 400 percent of the rated ampacity of the cables or cords as given in applicable tables of Articles 310 and 400. Plugging boxes shall not be permitted on ac systems.

(e) **Lighting.** Work lights, stand lamps, and fixtures shall be connected to plugging boxes by means of plugs containing two cartridge fuses not larger than 20 amperes, or they shall be permitted to be connected to special outlets on circuits protected by fuses or circuit breakers rated at not over 20 amperes. Plug fuses shall not be used unless they are on the load side of the fuse or circuit breakers on the "location boards."

### 530-19. Sizing of Feeder Conductors for Television Studio Sets.

(a) **General.** It shall be permissible to apply the demand factors listed in Table 530-19(a) to that portion of the maximum possible connected load for studio or stage set lighting for all permanently installed feeders between substations and stages and to all permanently installed feeders between the main stage switchboard and stage distribution centers or location boards.

Table 530-19(a). Demand Factors for Stage Set Lighting

Total Stage Set Lighting Load (Volt-amperes)	Feeder Demand Factor
First 50,000 or less at	100%
More than 50,000 to 100,000	75%
More than 100,000 to 200,000	60%
All over 200,000	50%

(b) **Portable Feeders.** A demand factor of 50 percent of maximum possible connected load shall be permitted for all portable feeders.

**530-20. Grounding.** Type MC cable, Type MI cable, metal raceways, and all noncurrent-carrying metal parts of appliances, devices, and equipment shall be grounded as specified in Article 250. This shall not apply to pendant and portable lamps, to stage lighting and stage sound equipment, nor to other portable and special stage equipment operating at not over 150 volts dc to ground.

**530-21. Plugs and Receptacles.** Plugs and receptacles shall be rated in amperes. All ac plugs and receptacles shall be grounded and polarized.

### C. Dressing Rooms

**530-31. Dressing Rooms.** Fixed wiring in dressing rooms shall be installed in accordance with wiring methods covered in Chapter 3. Wiring for portable dressing rooms shall be approved.

### D. Viewing, Cutting, and Patching Tables

**530-41. Lamps at Tables.** Only composition or metal-sheathed, porcelain, keyless lampholders equipped with suitable means to guard lamps from physical damage and from film and film scrap shall be used at patching, viewing, and cutting tables.

### E. Cellulose Nitrate Film Storage Vaults

**530-51. Lamps in Cellulose Nitrate Film Storage Vaults.** Lamps in cellulose nitrate film storage vaults shall be installed in rigid fixtures of the glass enclosed and gasketed type. Lamps shall be controlled by a switch having a pole in each ungrounded conductor. This switch shall be located outside of the vault and provided with a pilot light to indicate whether the switch is on or off. This switch shall disconnect from all sources of supply all ungrounded conductors terminating in any outlet in the vault.

**530-52. Motors and Other Equipment in Cellulose Nitrate Film Storage Vaults.** No receptacles, outlets, electric motors, heaters, portable lights, or other portable electric equipment shall be located in cellulose nitrate film storage vaults.

### F. Substations

**530-61. Substations.** Wiring and equipment of over 600 volts, nominal, shall comply with Article 710.

**530-62. Low-Voltage Switchboards.** On 600 volts, nominal, or less, switchboards shall comply with Article 384.

**530-63. Overcurrent Protection of DC Generators.** Three-wire dc generators shall have protection consisting of overcurrent devices having an ampere rating or setting in accordance with the generator ampere rating. Single-pole or double-pole overcurrent devices shall be permitted, and no pole or overcurrent coil shall be required in the neutral lead (whether it is grounded or ungrounded).

**530-64. Working Space and Guarding.** Working space and guarding in permanent fixed substations shall comply with Sections 110-16 and 110-17.

(FPN): For guarding of live parts on motors and generators, see Sections 430-11 and 430-14.

*Exception: Switchboards of not over 250 volts dc between conductors, when located in substations or switchboard rooms accessible to qualified persons only, shall not be required to be dead-front.*

**530-65. Portable Substations.** Wiring and equipment in portable substations shall conform to the sections applying to installations in permanently fixed substations, but, due to the limited space available, the working spaces shall be permitted to be reduced, provided that the equipment shall be so arranged that the operator can work safely, and so that other persons in the vicinity cannot accidentally come into contact with current-carrying parts or bring conducting objects into contact with them while they are energized.

**530-66. Grounding at Substations.** Noncurrent-carrying metal parts shall be grounded in accordance with Article 250.

*Exception: Frames of dc circuit breakers installed on switchboards.*

## ARTICLE 540 — MOTION PICTURE PROJECTORS

### A. General

**540-1. Scope.** The provisions of this article apply to motion picture projection rooms, motion picture projectors, and associated equipment of the professional and nonprofessional types using incandescent, carbon arc, Xenon, or other light source equipment which develops hazardous gases, dust, or radiation.

(FPN): For further information, see Storage and Handling of Cellulose Nitrate Motion Picture Film, NFPA 40-1982.

### B. Definitions

**540-2. Professional Projector:** The professional projector is a type using 35- or 70-millimeter film which has a minimum width of  $1\frac{3}{8}$  inches (35 mm) and has on each edge 5.4 perforations per inch, or a type using carbon arc, Xenon, or other light source equipment which develops hazardous gases, dust, or radiation.

**540-3. Nonprofessional Projector:** Nonprofessional projectors are those types other than described in Section 540-2.

### C. Equipment and Projectors of the Professional Type

**540-10. Motion Picture Projection Room Required.** Every professional-type projector shall be located within a projection room. Every projection room shall be of permanent construction, approved for the type of building in which the projection room is located. All projection ports, spotlight ports, viewing ports, and similar openings shall be provided with glass or other approved material so as to completely close the opening. Such rooms shall not be considered as hazardous (classified) locations as defined in Article 500.

(FPN): For further information on protecting openings in projection rooms handling cellulose nitrate motion picture film; see Life Safety Code, NFPA 101-1985 (ANSI).

**540-11. Location of Associated Electrical Equipment.**

(a) **Motor Generator Sets, Transformers, Rectifiers, Rheostats, and Similar Equipment.** Motor generator sets, transformers, rectifiers, rheostats, and similar equipment for the supply or control of current to projection or spotlight equipment shall, if practicable, be located in a separate room. Where placed in the projection room, they shall be so located or guarded that arcs or sparks cannot come in contact with film, and motor generator sets shall have the commutator end or ends protected as provided in Section 520-48.

(b) **Switches, Overcurrent Devices, or Other Equipment.** Switches, overcurrent devices, or other equipment not normally required or used for projectors, sound reproduction, flood or other special effect lamps, or other equipment shall not be installed in projection rooms.

*Exception No. 1: Remote control switches for the control of auditorium lights or switches for the control of motors operating curtains and masking of the motion picture screen.*

*Exception No. 2: In projection rooms approved for use only with cellulose acetate (safety) film, the installation of appurtenant electrical equipment used in conjunction with the operation of the projection equipment and the control of lights, curtains, and audio equipment, etc., shall be permitted. In such projection rooms, a sign reading "Safety Film Only Permitted in This Room" shall be posted on the outside of each projection room door and within the projection room itself in a conspicuous location.*

(c) **Emergency Systems.** Control of emergency systems shall comply with Article 700 — Emergency Systems.

**540-12. Work Space.** Each motion picture projector, floodlight, spotlight, or similar equipment shall have clear working space not less than 30 inches (762 mm) wide on each side and at the rear thereof.

*Exception: One such space shall be permitted between adjacent pieces of equipment.*

**540-13. Conductor Size.** Conductors supplying outlets for arc and Xenon projectors of the professional type shall not be smaller than No. 8 and shall be of sufficient size for the projector employed. Conductors for incandescent-type projectors shall conform to normal wiring standards as provided in Section 210-24.

**540-14. Conductors on Lamps and Hot Equipment.** Asbestos-covered conductors Type AA or other types of insulated conductors having a maximum operating temperature of 200°C (392°F) shall be used on all lamps or other equipment where the ambient temperature at the conductors as installed will exceed 50°C (122°F).

**540-15. Flexible Cords.** Cords approved for hard usage as provided in Table 400-4 shall be used on portable equipment.

**540-20. Approval.** Projectors and enclosures for arc, Xenon and incandescent lamps and rectifiers, transformers, rheostats and similar equipment shall be approved.

**540-21. Marking.** Projectors and other equipment shall be marked with the maker's name or trademark and with the voltage and current for which they are designed in accordance with Section 110-21.

#### D. Nonprofessional Projectors

**540-31. Motion Picture Projection Room Not Required.** Projectors of the nonprofessional or miniature type, when employing cellulose acetate (safety) film, shall be permitted to be operated without a projection room.

**540-32. Approval.** Projection equipment shall be listed.

#### E. Sound Recording and Reproduction

**540-50. Sound Recording and Reproduction.** Sound recording and reproduction equipment shall be installed as provided in Article 640.

## ARTICLE 545 — MANUFACTURED BUILDING

### A. General

**545-1. Scope.** This article covers requirements for a manufactured building and/or building components as herein defined.

**545-2. Other Articles.** Wherever the requirements of other articles of this Code and Article 545 differ, the requirements of Article 545 shall apply.

**545-3. Definitions.**

**Manufactured Building:** "Manufactured Building" means any building which is of closed construction and which is made or assembled in manufacturing facilities on or off the building site for installation, or assembly and installation on the building site, other than mobile homes or recreational vehicles.

**Building Component:** "Building Component" means any subsystem, subassembly, or other system designed for use in or integral with or as part of a structure, which can include structural, electrical, mechanical, plumbing, and fire protection systems, and other systems affecting health and safety.

**Building System:** "Building System" means plans, specifications, and documentation for a system of manufactured building or for a type or a system of building components, which can include structural, electrical, mechanical, plumbing, and fire protection systems, and other systems affecting health and safety, and including such variations thereof as are specifically permitted by regulation, and which variations are submitted as part of the building system or amendment thereto.

**Closed Construction:** "Closed Construction" means any building, building component, assembly, or system manufactured in such a manner that all concealed parts of processes of manufacture cannot be inspected before installation at the building site without disassembly, damage, or destruction.

**545-4. Wiring Methods.**

(a) **Methods Permitted.** All raceway and cable wiring methods included in this Code and such other wiring systems specifically intended and listed for use in manufactured buildings shall be permitted with listed fittings and with fittings listed and identified for manufactured buildings.

(b) **Securing Cables.** In closed construction, cables shall be permitted to be secured only at cabinets, boxes, or fittings where No. 10 AWG or smaller conductors are used and protection against physical damage is provided as required by Section 300-4.

**545-5. Service-Entrance Conductors.** Service-entrance conductors shall meet the requirements of Article 230. Provisions shall be made to route the service-entrance conductors from the service equipment to the point of attachment of the service.

(FPN): See Section 310-10 for temperature limitation of conductors.

**545-6. Installation of Service-Entrance Conductors.** Service-entrance conductors shall be installed after erection at the building site.

*Exception: Where point of attachment is known prior to manufacture.*

**545-7. Service Equipment Location.** The service equipment shall be located at a readily accessible point nearest to the entrance of the conductors either inside or outside the building.

**545-8. Protection of Conductors and Equipment.** Protection shall be provided for exposed conductors and equipment during processes of manufacturing, packaging, in transit, and erection at the building site.

**545-9. Boxes.**

(a) **Other Dimensions.** Boxes of dimensions other than those required in Table 370-6(a) shall be permitted to be installed when tested, identified, and listed to applicable standards.

(b) **Not Over 100 Cubic Inches.** Any box not over 100 cubic inches in size, intended for mounting in closed construction, shall be affixed with anchors or clamps so as to provide a rigid and secure installation.

**545-10. Receptacle or Switch with Integral Enclosure.** A receptacle or switch with integral enclosure and mounting means, when tested, identified, and listed to applicable standards, shall be permitted to be installed.

**545-11. Bonding and Grounding.** Prewired panels and/or building components shall provide for the bonding and/or grounding of all exposed metals likely to become energized, in accordance with Article 250, Parts E, F, and G.

**545-12. Grounding Electrode Conductor.** The grounding electrode conductor shall meet the requirements of Article 250, Part J. Provisions shall be made to route the grounding electrode conductor from the service equipment to the point of attachment to the grounding electrode.

**545-13. Component Interconnections.** Fittings and connectors which are intended to be concealed at the time of on-site assembly, when tested, identified, and listed to applicable standards, shall be permitted for on-site interconnection of modules or other building components. Such fittings and

connectors shall be equal to the wiring method employed in insulation, temperature rise, fault-current withstand and shall be capable of enduring the vibration and minor relative motions occurring in the components of manufactured building.

## ARTICLE 547 — AGRICULTURAL BUILDINGS

**547-1. Scope.** The provisions of this article shall apply to the following agricultural buildings or that part of a building as specified in (a) and (b) below.

(a) **Excessive Dust and Dust with Water.** Agricultural buildings where excessive dust and dust with water may accumulate. Such buildings include all areas of totally enclosed and environmentally controlled poultry and livestock confinement systems; where litter dust, feed dust, including mineral feed particles, may accumulate and enclosed areas of similar or like nature.

(b) **Corrosive Atmosphere.** Agricultural buildings where a corrosive atmosphere exists. Such buildings include totally enclosed and environmentally controlled areas where (1) poultry and animal excrement may cause corrosive vapors in the confinement area; (2) corrosive particles may combine with water; (3) the area is damp and wet by reason of periodic washing for cleaning and sanitizing with water and cleansing agents; (4) similar conditions exist.

**547-2. Other Articles.** For agricultural buildings not having conditions as specified in Section 547-1, the electrical installations shall be made in accordance with the applicable articles in this Code.

**547-3. General.** Electrical equipment or devices installed in accordance with the provisions of this article shall be installed in a manner such that they will function at full rating without developing surface temperatures in excess of the specified normal safe operating range of the equipment or device.

**547-4. Wiring Methods.** In agricultural buildings as described in Section 547-1(a) and (b), Types UF, NMC, SNM, copper-SE, or other cables or raceways suitable for the location, with approved termination fittings, shall be the wiring methods employed. Article 320 wiring methods shall be permitted for Section 547-1(a). Buildings wired in accordance with the provisions of Article 502 shall be permitted. All cables shall be secured within 8 inches (203 mm) of each cabinet, box, or fitting.

(FPN): See Sections 300-7 and 347-9 for installation of raceway systems exposed to widely different temperatures.

(a) **Boxes, Fittings, and Wiring Devices.** All boxes and fittings shall comply with Section 547-5.

(b) **Flexible Connections.** Where necessary to employ flexible connections, dusttight flexible connectors, liquidtight flexible metal conduit, or flexible cord listed and identified for hard usage shall be used. All shall be used with listed and identified fittings.

**547-5. Switches, Circuit Breakers, Controllers, and Fuses.** Switches, circuit breakers, controllers, and fuses, including pushbuttons, relays and similar devices, used in buildings described in Section 547-1(a) and (b), shall be



provided with a weatherproof, corrosion-resistant enclosure designed to minimize the entrance of dust, water, and corrosive elements, and shall be equipped with a telescoping or close-fitting cover.

**547-6. Motors.** Motors and other rotating electrical machinery shall be totally enclosed or so designed as to minimize the entrance of dust, moisture, or corrosive particles.

**547-7: Lighting Fixtures.** Lighting fixtures installed in agricultural buildings described in Section 547-1 shall comply with the following:

(a) **Minimize the Entrance of Dust.** Lighting fixtures shall be installed to minimize the entrance of dust, foreign matter, moisture, and corrosive material.

(b) **Exposed to Physical Damage.** Any lighting fixture that may be exposed to physical damage shall be protected by a suitable guard.

(c) **Exposed to Water.** A fixture that may be exposed to water from condensation and/or building cleansing water or solution shall be watertight.

**547-8. Grounding, Bonding, and Equipotential Plane.**

(a) **Grounding and Bonding.** Grounding and bonding shall comply with Article 250.

(FPN): See Section 250-21 for objectionable current over grounding conductors.

*Exception: The main bonding jumper shall not be required at the distribution panelboard in or on buildings housing livestock or poultry where all the following conditions are met:*

*a. All buildings and premises wiring are under the same ownership.*

*b. An equipment grounding conductor of the same size as the circuit conductors is run with the supply conductors.*

*c. Service disconnecting means is provided at the distribution point for supply to those buildings.*

*d. The equipment grounding conductor is bonded to the grounded circuit conductor at the service equipment.*

*e. A grounding electrode is provided and connected to the equipment grounding conductor in the distribution panelboard.*

(b) **Concrete Embedded Elements.** Wire mesh or other conductive elements where provided in the concrete floor of animal confinement areas to provide an equipotential plane shall be bonded to the building grounding electrode system. The bonding conductor shall be copper, insulated, covered or bare, not smaller than No. 8. The means of bonding to wire mesh or conductive elements shall be by pressure connectors or clamps of brass, copper, copper alloy or an equally substantial approved means.

**Equipotential Plane:** An equipotential plane is an area where a wire mesh or other conductive elements are embedded in concrete, bonded to all adjacent conductive equipment, structures, or surfaces and connected to the electrical grounding system to prevent a difference in voltage from developing within the plane.

(FPN): If a wire mesh or other conductive grid is embedded in a concrete floor or platform, and if this grid is bonded to the electrical system grounding bus, livestock making contact between the concrete floor or platform and the equip-

ment or metal structure will be less likely to be exposed to a level of voltage that may alter animal behavior or productivity.

(c) **Separate Equipment Grounding Conductor.** In agricultural buildings as described in Sections 547-1(a) and (b), noncurrent-carrying metal parts of equipment, raceways, and other enclosures where required to be grounded, shall be grounded by a copper equipment grounding conductor installed between the equipment and the building disconnecting means. If installed underground, the equipment grounding conductor shall be insulated or covered.

(FPN): Grounding electrode system resistances lower than required by Article 250, Part H, may reduce potential differences in livestock facilities.

## ARTICLE 550 — MOBILE HOMES AND MOBILE HOME PARKS

**550-1. Scope.** The provisions of this article cover the electrical conductors and equipment installed within or on mobile homes, the conductors that connect mobile homes to a supply of electricity, and the installation of electrical wiring, fixtures, equipment, and appurtenances related to electrical installations within a mobile home park up to the mobile home service-entrance conductors or, if none, the mobile home service equipment.

### 550-2. Definitions.

**Appliance, Fixed:** An appliance which is fastened or otherwise secured at a specific location.

**Appliance, Portable:** An appliance which is actually moved or can easily be moved from one place to another in normal use.

(FPN): For the purpose of this article, the following major appliances other than built-in are considered portable if cord-connected: refrigerators, gas range equipment, clothes washers, dishwashers without booster heaters, or other similar appliances.

**Appliance, Stationary:** An appliance which is not easily moved from one place to another in normal use.

**Distribution Panelboard:** See definition of panelboard in Article 100.

**Feeder Assembly:** The overhead or under-chassis feeder conductors, including the grounding conductor, together with the necessary fittings and equipment or a power-supply cord listed for mobile home use, designed for the purpose of delivering energy from the source of electrical supply to the distribution panelboard within the mobile home.

**Laundry Area:** An area containing or designed to contain either a laundry tray, clothes washer, and/or a clothes dryer.

**Mobile Home:** A factory-assembled structure or structures equipped with the necessary service connections and made so as to be readily movable as a unit or units on its own running gear and designed to be used as a dwelling unit(s) without a permanent foundation.

(FPN): The phrase "without a permanent foundation" indicates that the support system is constructed with the intent that the mobile home placed thereon will be moved from time to time at the convenience of the owner.

**Mobile Home Accessory Building or Structure:** Any awning, cabana, ramada, storage cabinet, carport, fence, windbreak, or porch established for the use of the occupant of the mobile home upon a mobile home lot.

**Mobile Home Lot:** A designated portion of a mobile home park designed for the accommodation of one mobile home and its accessory buildings or structures for the exclusive use of its occupants.

**Mobile Home Park:** A contiguous parcel of land which is used for the accommodation of occupied mobile homes.

**Mobile Home Service Equipment:** The equipment containing the disconnecting means, overcurrent protective devices, and receptacles or other means for connecting a mobile home feeder assembly.

**Park Electrical Wiring Systems:** All of the electrical wiring, fixtures, equipment, and appurtenances related to electrical installations within a mobile home park, including the mobile home service equipment.

**550-3. Other Articles.** Wherever the requirements of other articles of this Code and Article 550 differ, the requirements of Article 550 shall apply.

**550-4. General Requirements.**

(a) **Mobile Home Not Intended as a Dwelling Unit.** A mobile home not intended as a dwelling unit, as for example equipped for sleeping purposes only, contractor's on-site offices, construction job dormitories, mobile studio dressing rooms, banks, clinics, mobile stores, or intended for the display or demonstration of merchandise or machinery, shall not be required to meet the provisions of this article pertaining to the number or capacity of circuits required. It shall, however, meet all other applicable requirements of this article if provided with an electrical installation intended to be energized from a 120-volt or 120/240-volt ac power supply system. Where different voltage is required by either design or available power supply system, adjustment shall be made in accordance with other articles and sections for the voltage used.

(b) **In Other than Mobile Home Parks.** Mobile homes installed in other than mobile home parks shall comply with the provisions of this article.

(c) **Connection to Wiring System.** The provisions of this article apply to mobile homes intended for connection to a wiring system rated 120/240 volts, nominal, 3-wire ac, with grounded neutral.

(d) **Listed or Labeled.** All electrical materials, devices, appliances, fittings, and other equipment shall be listed or labeled by a qualified testing agency and shall be connected in an approved manner when installed.

## A. Mobile Homes

**550-5. Power Supply.**

(a) **Service Equipment.** The mobile home service equipment shall be located adjacent to the mobile home and not mounted in or on the mobile home. The power supply to the mobile home shall be a feeder assembly consisting of not more than one listed 50-ampere mobile home power-supply cord with integral molded cap, or a permanently installed circuit.

*Exception: A mobile home that is factory-equipped with gas or oil-fired central heating equipment and cooking appliances shall be permitted to be provided with a listed mobile home power-supply cord rated 40 amperes.*

**(b) Power-Supply Cord.** If the mobile home has a power-supply cord, it shall be permanently attached to the distribution panelboard or to a junction box permanently connected to the distribution panelboard, with the free end terminating in an attachment plug cap.

Cords with adapters and pigtail ends, extension cords, and similar items shall not be attached to, or shipped with, a mobile home.

A suitable clamp or the equivalent shall be provided at the distribution panelboard knockout to afford strain relief for the cord to prevent strain from being transmitted to the terminals when the power-supply cord is handled in its intended manner.

The cord shall be a listed type with four conductors, one of which shall be identified by a continuous green color or a continuous green color with one or more yellow stripes for use as the grounding conductor.

**(c) Attachment Plug Cap.** The attachment plug cap shall be a 3-pole, 4-wire, grounding type, rated 50 amperes, 125/250 volts with a configuration as shown in Figure 550-5(c) and intended for use with the 50-ampere, 125/250 receptacle configuration shown in Figure 550-5(c). It shall be molded of butyl rubber, neoprene, or other materials which have been found suitable for the purpose, and shall be molded to the flexible cord so that it adheres tightly to the cord at the point where the cord enters the attachment plug cap. If a right-angle cap is used, the configuration shall be so oriented that the grounding member is farthest from the cord.

(FPN): Complete details of the 50-ampere plug and receptacle shown in Figure 550-5(c) can be found in ANSI Standard Dimensions of Caps, Plugs and Receptacles, C73.17-1972.

Receptacle



Cap



125 / 250-volt, 50-amp,  
3-pole, 4-wire, grounding type

**Figure 550-5(c).** 50-ampere, 125/250 volt receptacle and attachment-plug-cap configurations, 3-pole, 4-wire, grounding types, used for mobile home supply cords and mobile home parks.

**(d) Overall Length of a Power-Supply Cord.** The overall length of a power-supply cord, measured from the end of the cord, including bared leads, to the face of the attachment plug cap shall not be less than 21 feet (6.4 m) and shall not exceed 36½ feet (11.13 m). The length of the cord from the face of the attachment plug cap to the point where the cord enters the mobile home shall not be less than 20 feet (6.1 m).

**(e) Marking.** The power-supply cord shall bear the following marking: "For use with mobile homes — 40 amperes" or "For use with mobile homes — 50 amperes."

**(f) Point of Entrance.** The point of entrance of the feeder assembly to the mobile home shall be in the exterior wall, floor, or roof.

(FPN): For location of distribution panelboard, see Section 550-6(a).

(FPN): For location of attachment of feeder assembly, see Section 550-23(d).

**(g) Protected.** Where the cord passes through walls or floors, it shall be protected by means of conduits and bushings or equivalent. The cord shall be permitted to be installed within the mobile home walls, provided a continuous raceway having a maximum size of 1¼ inches (31.8 mm) is installed from the branch-circuit panelboard to the underside of the mobile home floor.

**(h) Protection Against Corrosion and Mechanical Damage.** Permanent provisions shall be made for the protection of the attachment plug cap of the power-supply cord and any connector cord assembly or receptacle against corrosion and mechanical damage if such devices are in an exterior location while the mobile home is in transit.

**(i) Mast Weatherhead or Raceway.** Where the calculated load exceeds 50 amperes or where a permanent feeder is used, the supply shall be by means of:

(1) One mast weatherhead installation installed in accordance with Article 230 containing four continuous, insulated, color-coded, feeder conductors, one of which shall be an equipment grounding conductor; or,

(2) A metal raceway or rigid nonmetallic conduit from the disconnecting means in the mobile home to the underside of the mobile home with provisions for the attachment to a suitable junction box or fitting to the raceway on the underside of the mobile home [with or without conductors as in Section 550-5(i)(1)].

#### **550-6. Disconnecting Means and Branch-Circuit Protective Equipment.**

The branch-circuit equipment shall be permitted to be combined with the disconnecting means as a single assembly. Such a combination shall be permitted to be designated as a distribution panelboard. If a fused distribution panelboard is used, the maximum fuse size for the mains shall be plainly marked, with lettering at least ¼ inch (6.4 mm) high and visible when fuses are changed.

When plug fuses and fuseholders are used, they shall be tamper-resistant, Type S enclosed in dead-front fuse panelboards. Electrical distribution panelboards containing circuit breakers shall also be dead-front type.

(FPN): See Section 110-22 concerning identification of each disconnecting means and each service, feeder, or branch circuit at the point where it originated and the type marking needed.

**(a) Disconnecting Means.** A single disconnecting means shall be provided in each mobile home consisting of a circuit breaker, or a switch and fuses and its accessories installed in a readily accessible location near the point of entrance of the supply cord or conductors into the mobile home. The main circuit breakers or fuses shall be plainly marked "Main." This equipment shall contain a solderless type of grounding connector or bar for the purposes of grounding with sufficient terminals for all grounding conductors. The neutral bar termination of the grounded circuit conductors shall be insulated in accordance with Section 550-11(a). The disconnecting equipment shall have a rating suitable for the connected load. The distribution equipment, either circuit breaker or fused type, shall be located a minimum of 24 inches (610 mm) from the bottom of such equipment to the floor level of the mobile home.

(FPN): See Section 550-15(b) for information on disconnecting means for branch circuits designed to energize heating and/or air-conditioning equipment located outside the mobile home, other than room air conditioners.

A distribution panelboard main circuit breaker shall be rated 50 amperes and employ a 2-pole circuit breaker rated 40 amperes for a 40-ampere supply cord, or 50 amperes for a 50-ampere supply cord. A distribution panelboard employing a disconnect switch and fuses shall be rated 60 amperes and shall employ a single 2-pole, 60-ampere fuseholder with 40- or 50-ampere main fuses for 40- or 50-ampere supply cords, respectively. The outside of the distribution panelboard shall be plainly marked with the fuse size.

The distribution panelboard shall be located in an accessible location, shall not be located in a bathroom, and shall be permitted to be located just inside a closet entry if the location is such that a clear space of 6 inches (152 mm) to easily ignitable materials is maintained in front of the distribution panelboard, and the distribution panelboard door can be extended to its full open position (at least 90 degrees). A clear working space at least 30 inches (762 mm) wide and 30 inches (762 mm) in front of the distribution panelboard shall be provided. This space shall extend from floor to the top of the distribution panelboard.

**(b) Branch-Circuit Protective Equipment.** Branch-circuit distribution equipment shall be installed in each mobile home and shall include overcurrent protection for each branch circuit consisting of either circuit breakers or fuses.

The branch-circuit overcurrent devices shall be rated: (1) not more than the circuit conductors; and (2) not more than 150 percent of the rating of a single appliance rated 13.3 amperes or more which is supplied by an individual branch circuit; but (3) not more than the fuse size marked on the air conditioner or other motor-operated appliance.

A 15-ampere multiple receptacle shall be permitted when connected to a 20-ampere laundry circuit.

**(c) Two-Pole Circuit Breakers.** When circuit breakers are provided for branch-circuit protection, 240-volt circuits shall be protected by a 2-pole common or companion trip, or handle-tied paired circuit breakers.

**(d) Electrical Nameplates.** A metal nameplate on the outside adjacent to the feeder assembly entrance shall read: "This Connection for 120/240-Volt, 3-Pole, 4-Wire, 60 Hertz, . . . Ampere Supply." The correct ampere rating shall be marked in the blank space.

**550-7. Branch Circuits.** The number of branch circuits required shall be determined in accordance with (a) through (c) below.

**(a) Lighting.** Based on 3 volt-amperes per square foot (0.093 sq m) times outside dimensions of the mobile home (coupler excluded) divided by 120 volts to determine the number of 15- or 20-ampere lighting area circuits, e.g.,

$$\frac{3 \times \text{Length} \times \text{Width}}{120 \times 15 \text{ (or } 20)} = \text{No. of 15- (or 20-) ampere circuits.}$$

The lighting circuits shall be permitted to serve built-in gas ovens with electric service only for lights, clocks or timers, or listed cord-connected garbage disposal units.

**(b) Small Appliances.** For the small appliance load in kitchen, pantry, family room, dining room, and breakfast rooms of mobile homes, two or more 20-ampere appliance branch circuits in addition to the branch circuits specified in Section 550-7(a) shall be provided for all receptacle outlets in these rooms, and such circuits shall have no other outlets. Receptacle outlets supplied by at least two appliance receptacle branch circuits shall be installed in the kitchen.

**(c) General Appliances.** (Including furnace, water heater, range, and central or room air conditioner, etc.) There shall be one or more circuits of adequate rating in accordance with the following:

(1) Ampere rating of fixed appliances not over 50 percent of circuit rating if lighting outlets (receptacles, other than kitchen, dining area, and laundry, considered as lighting outlets) are on the same circuit;

(2) For fixed appliances on a circuit without lighting outlets, the sum of rated amperes shall not exceed the branch-circuit rating. Motor loads or other continuous duty loads shall not exceed 80 percent of the branch-circuit rating;

(3) The rating of a single cord- and plug-connected appliance on a circuit having no other outlets shall not exceed 80 percent of the circuit rating;

(4) The rating of a range branch circuit shall be based on the range demand as specified for ranges in Section 550-13(b)(5).

(FPN): For the laundry branch circuit, see Section 220-4(c).

(FPN): For central air conditioning, see Article 440.

#### 550-8. Receptacle Outlets.

**(a) Grounding-type Receptacle Outlets.** All receptacle outlets: (1) shall be of grounding type; (2) shall be installed according to Section 210-7; and (3) except when supplying specific appliances, receptacles shall be 15- or 20-ampere, 125-volt, either single or duplex and shall accept parallel-blade attachment plugs.

**(b) Ground-Fault Circuit-Interrupters.** All 120-volt, single-phase, 15- and 20-ampere receptacle outlets installed outdoors and in bathrooms, including receptacles in light fixtures, shall have ground-fault circuit protection for personnel. Ground-fault circuit protection for personnel shall be provided for receptacle outlets located adjacent to any lavatory. Feeders supplying branch circuits shall be permitted to be protected by a ground-fault circuit-interrupter in lieu of the provision for such interrupters specified herein.

No receptacle shall be required in the area occupied by a toilet, toilet and/or shower, or toilet and tub/shower enclosure area. If a receptacle is installed in such an area, it shall have ground-fault circuit protection for personnel.

**(c) Cord-Connected Fixed Appliance.** A grounding-type receptacle outlet shall be provided for each cord-connected fixed appliance installed.

**(d) Required Receptacle Outlets.** Receptacle outlets required in all rooms other than the bath, closet, and hall areas shall be installed so that no point along the floor line is more than 6 feet (1.83 m) measured horizontally from an outlet in that space. Countertops shall have receptacles located every 6 feet (1.83 m). The contiguous measurement of countertop and floor line shall be permitted when measured from the required receptacle in rooms requiring small appliance circuits. Receptacle outlets on small appliance circuits shall

not be included in determining the spacing for receptacle outlets of other circuits.

*Exception No. 1: Where the measured distance is interrupted by an interior doorway, sink, refrigerator, range, oven, or cooktop, an additional receptacle outlet shall be provided when the interrupted space is at least 2 feet (610 mm) wide at the floor line and at least 12 inches (305 mm) wide at the countertop.*

*Exception No. 2: Receptacles concealed by stationary appliances shall not be considered as the required outlets.*

*Exception No. 3: The distance along a floor line occupied by a door opened fully against that space need not be included in establishing the horizontal measurement if the door swing is limited to 90 degrees nominal by that wall space.*

*Exception No. 4: Receptacle requirements for bar-type counters and for fixed room dividers no more than 8 feet (2.44 m) in length shall be permitted to be provided by a receptacle outlet in the wall at the nearest point where the counter or room divider attaches to the wall.*

(FPN): To qualify as a "fixed room divider" the divider cannot be more than 8 feet (2.44 m) in length nor more than 4 feet (1.22 m) in height and may be attached to a wall at one end only.

**(e) Outdoor Receptacle Outlets.** At least one receptacle outlet shall be installed outdoors. A receptacle outlet located in a compartment accessible from the outside of the mobile home shall be considered an outdoor receptacle. Outdoor receptacle outlets shall be protected as required in Section 550-8(b).

**(f) Receptacle Outlets Not Permitted.** Receptacle outlets shall not be installed in or within reach [30 inches (762 mm)] of a shower or bathtub space.

**(g) Heat Tape Outlet.** A heat tape outlet, if installed, and if located on the underside of the mobile home at least 3 feet (914 mm) from the outside edge, shall not be considered an outdoor receptacle outlet. A heat tape outlet, if installed, shall be located within 2 feet (610 mm) of the cold water inlet.

#### **550-9. Fixtures and Appliances.**

**(a) Fasten Appliances in Transit.** Facilities shall be provided to securely fasten appliances when the mobile home is in transit. (See Section 550-11 for provisions on grounding.)

**(1)** Pendant-type fixtures or pendant cords shall be listed and identified for the interconnection of building components.

**(2)** Where a lighting fixture is installed over a bathtub or in a shower stall, it shall be of the enclosed and gasketed type listed for wet locations.

**(3)** The switch for shower lighting fixtures and exhaust fans located over a tub or in a shower stall shall be located outside the tub or shower space.

**(b) Accessibility.** Every appliance shall be accessible for inspection, service, repair, or replacement without removal of permanent construction.

**550-10. Wiring Methods and Materials.** Except as specifically limited in this section, the wiring methods and materials included in this Code shall be used in mobile homes.



(a) **Nonmetallic Boxes.** Nonmetallic boxes shall be permitted only with nonmetallic cable or nonmetallic conduit.

(b) **Nonmetallic Cable Protection.** Nonmetallic cable located 15 inches (381 mm) or less above the floor, if exposed, shall be protected from physical damage by covering boards, guard strips, or raceways. Cable likely to be damaged by stowage shall be so protected in all cases.

(c) **Metal-Covered and Nonmetallic Cable Protection.** Metal-covered and nonmetallic cables shall be permitted to pass through the centers of the wide side of 2-inch by 4-inch studs. However, they shall be protected where they pass through 2-inch by 2-inch studs or at other studs or frames where the cable or armor would be less than 1½ inches (38 mm) from the inside or outside surface of the studs where the wall covering materials are in contact with the studs. Steel plates on each side of the cable, or a tube, with not less than No. 16 MSG wall thickness shall be required to protect the cable. These plates or tubes shall be securely held in place.

(d) **Metal Faceplates.** Where metal faceplates are used, they shall be effectively grounded.

(e) **Installation Requirements.** If a range, clothes dryer, or similar appliance is connected by metal-covered cable or flexible metal conduit, a length of free cable or conduit shall be provided to permit moving the appliance. The cable or flexible metal conduit shall be secured to the wall. A length of not less than 3 feet (914 mm) of free cable or conduit shall be provided to permit moving the appliance. Type NM or Type SE cable shall not be used to connect a range or dryer. This shall not prohibit the use of Type NM or Type SE cable between the branch-circuit overcurrent protective device and a junction box or range or dryer receptacle.

(f) **Conduit.** Where rigid metal conduit or intermediate metal conduit is terminated at an enclosure with a locknut and bushing connection, two locknuts shall be provided, one inside and one outside of the enclosure. Rigid nonmetallic conduit shall be permitted. All cut ends of conduit shall be reamed or otherwise finished to remove rough edges.

(g) **Switches.** Switches shall be rated as follows:

(1) For lighting circuits, switches shall have a 10-ampere, 120-125-volt rating, or higher, if needed for the connected load.

(2) For motors or other loads, switches shall have ampere or horsepower ratings, or both, adequate for loads controlled. (An "ac general-use" snap switch shall be permitted to control a motor 2 horsepower or less with full-load current not over 80 percent of the switch ampere rating.)

(h) **Free Conductor at Each Box.** At least 4 inches (102 mm) of free conductor shall be left at each box except where conductors are intended to loop without joints.

(i) **Under-Chassis Wiring.** (Exposed to weather.)

(1) Where outdoor or under-chassis line-voltage wiring is exposed to moisture or physical damage, it shall be protected by rigid metal conduit or intermediate metal conduit. The conductors shall be suitable for wet locations.

*Exception: Electrical metallic tubing or rigid nonmetallic conduit shall be permitted where closely routed against frames and equipment enclosures.*

(2) The cables or conductors shall be Type NMC, TW, or equivalent.

(j) **Boxes, Fittings, and Cabinets.** Boxes, fittings, and cabinets shall be securely fastened in place and shall be supported from a structural member of the home, either directly or by using a substantial brace.

*Exception: Snap-in type boxes. Boxes provided with special wall or ceiling brackets and wiring devices with integral enclosures, which securely fasten to walls or ceilings and are identified for the use, shall be permitted without support from a structural member or brace. The testing and approval shall include the wall and ceiling construction systems for which the boxes and devices are intended to be used.*

(k) **Appliance Terminal Connections.** Appliances having branch-circuit terminal connections which operate at temperatures higher than 60°C (140°F) shall have circuit conductors as described in (1) or (2) below.

(1) Branch-circuit conductors having an insulation suitable for the temperature encountered shall be permitted to be run directly to the appliance.

(2) Conductors having an insulation suitable for the temperature encountered shall be run from the appliance terminal connection to a readily accessible outlet box placed at least 1 foot (305 mm) from the appliance. These conductors shall be in a suitable raceway which shall extend for at least 4 feet (1.22 m).

(l) **Component Interconnections.** Fittings and connectors which are intended to be concealed at the time of assembly shall be listed and identified for the interconnection of building components. Such fittings and connectors shall be equal to the wiring method employed in insulation, temperature rise, fault-current withstanding, and shall be capable of enduring the vibration and shock occurring in mobile home transportation.

**550-11. Grounding.** Grounding of both electrical and nonelectrical metal parts in a mobile home shall be through connection to a grounding bus in the mobile home distribution panelboard. The grounding bus shall be grounded through the green-colored insulated conductor in the supply cord or the feeder wiring to the service ground in the service-entrance equipment located adjacent to the mobile home location. Neither the frame of the mobile home nor the frame of any appliance shall be connected to the neutral conductor in the mobile home.

(a) **Insulated Neutral.**

(1) The grounded circuit conductor (neutral) shall be insulated from the grounding conductors and from equipment enclosures and other grounded parts. The grounded (neutral) circuit terminals in the distribution panelboard and in ranges, clothes dryers, counter-mounted cooking units, and wall-mounted ovens shall be insulated from the equipment enclosure. Bonding screws, straps, or buses in the distribution panelboard or in appliances shall be removed and discarded.

(2) Connections of ranges and clothes dryers with 120/240-volt, 3-wire ratings shall be made with 4-conductor cord and 3-pole, 4-wire, grounding-type plugs, or by Type AC cable, Type MC cable, or conductors enclosed in flexible metal conduit.

**(b) Equipment Grounding Means.**

(1) The green-colored insulated grounding wire in the supply cord or permanent feeder wiring shall be connected to the grounding bus in the distribution panelboard or disconnecting means.

(2) In the electrical system, all exposed metal parts, enclosures, frames, lamp fixture canopies, etc., shall be effectively bonded to the grounding terminal or enclosure of the distribution panelboard.

(3) Cord-connected appliances, such as washing machines, clothes dryers, refrigerators, and the electrical system of gas ranges, etc., shall be grounded by means of a cord with grounding conductor and grounding-type attachment plug.

**(c) Bonding of Noncurrent-Carrying Metal Parts.**

(1) All exposed noncurrent-carrying metal parts that may become energized shall be effectively bonded to the grounding terminal or enclosure of the distribution panelboard. A bonding conductor shall be connected between the distribution panelboard and accessible terminal on the chassis.

(2) Grounding terminals shall be of the solderless type and listed as pressure-terminal connectors recognized for the wire size used. The bonding conductor shall be solid or stranded, insulated or bare, and shall be No. 8 copper minimum, or equal. The bonding conductor shall be routed so as not to be exposed to physical damage.

(3) Metallic gas, water, and waste pipes and metallic air-circulating ducts shall be considered bonded if they are connected to the terminal on the chassis [see Section 550-11(c)(1)] by clamps, solderless connectors, or by suitable grounding-type straps.

(4) Any metallic roof and exterior covering shall be considered bonded if (a) the metal panels overlap one another and are securely attached to the wood or metal frame parts by metallic fasteners, and (b) if the lower panel of the metallic exterior covering is secured by metallic fasteners at a cross member of the chassis by two metal straps per mobile home unit or section at opposite ends.

The bonding strap material shall be a minimum of 4 inches (102 mm) in width of material equivalent to the skin or a material of equal or better electrical conductivity. The straps shall be fastened with paint-penetrating fittings, such as screws and starwashers or equivalent.

**550-12: Testing.**

(a) **Dielectric Strength Test.** The wiring of each mobile home shall be subjected to a 1-minute, 900-volt, dielectric strength test (with all switches closed) between live parts (including neutral) and the mobile home ground. Alternatively, the test shall be permitted to be performed at 1,080 volts for 1 second. This test shall be performed after branch circuits are complete and after fixtures or appliances are installed.

*Exception: Listed fixtures or appliances shall not be required to withstand the dielectric strength test.*

(b) **Continuity and Operational Tests and Polarity Checks.** Each mobile home shall be subjected to:

(1) An electrical continuity test to assure that all exposed electrically conductive parts are properly bonded;

(2) An electrical operational test to demonstrate that all equipment, except water heaters and electric furnaces, is connected and in working order; and

(3) Electrical polarity checks of permanently wired equipment and receptacle outlets to determine that connections have been properly made.

**550-13. Calculations.** The following method shall be employed in computing the supply-cord and distribution-panelboard load for each feeder assembly for each mobile home in lieu of the procedure shown in Article 220 and shall be based on a 3-wire, 120/240-volt supply with 120-volt loads balanced between the two legs of the 3-wire system.

**(a) Lighting and Small Appliance Load:**

Lighting Volt-Amperes: Length times width of mobile home floor (outside dimensions) times 3 volt-amperes per square foot; e.g.,  
 Length X width X 3 = .....lighting volt-amperes.

Small Appliance Volt-Amperes: Number of circuits times 1,500 volt-amperes for each 20-ampere appliance receptacle circuit (see definition of Appliance, Portable with note) including 1,500 volt-amperes for laundry circuit; e.g.,

Number of circuits X 1,500 = .....small appliance volt-amperes.

Total: Lighting volt-amperes plus small appliance = .....total volt-amperes.

First 3,000 total volt-amperes at 100 percent plus remainder at 35 percent = .....volt-amperes to be divided by 240 volts to obtain current (amperes) per leg.

**(b) Total Load for Determining Power Supply.** Total load for determining power supply is the summation of:

(1) Lighting and small appliance load as calculated in Section 550-13(a).

(2) Nameplate amperes for motors and heater loads (exhaust fans, air conditioners, electric, gas, or oil heating).

Omit smaller of the heating and cooling loads, except include blower motor if used as air-conditioner evaporator motor. Where an air conditioner is not installed and a 40-ampere power supply cord is provided, allow 15 amperes per leg for air conditioning.

(3) 25 percent of current of largest motor in (2).

(4) Total of nameplate amperes for: disposal, dishwasher, water heater, clothes dryer, wall-mounted oven, cooking units.

Where number of these appliances exceeds three, use 75 percent of total.

(5) Derive amperes for free-standing range (as distinguished from separate ovens and cooking units) by dividing values below by 240 volts.

Nameplate Rating	Use
0 thru 10,000 watts	80 percent of rating
over 10,000 thru 12,500 watts	8,000 volt-amperes
over 12,500 thru 13,500 watts	8,400 volt-amperes
over 13,500 thru 14,500 watts	8,800 volt-amperes
over 14,500 thru 15,500 watts	9,200 volt-amperes
over 15,500 thru 16,500 watts	9,600 volt-amperes
over 16,500 thru 17,500 watts	10,000 volt-amperes

(6) If outlets or circuits are provided for other than factory-installed appliances, include the anticipated load.

See following Example for illustration of application of this calculation.

#### Example

A mobile home floor is 70 feet  $\times$  10 feet and has two small appliance circuits, a 1000-volt-ampere, 240-volt heater, a 200-volt-ampere, 120-volt exhaust fan, a 400-volt-ampere, 120-volt dishwasher, and a 7000-volt-ampere electric range.

#### Lighting and small appliance load

Lighting $70 \times 10 \times 3$ VA/sq ft =	2100 volt-amperes
Small appliance $1500 \times 2$ =	3000 volt-amperes
Laundry $1500 \times 1$ =	<u>1500 volt-amperes</u>
	6600 volt-amperes
1st 3000 volt-amperes at 100 percent .....	3000 volt-amperes
Remainder (6600 - 3000) at 35 percent .....	<u>1260 volt-amperes</u>
	4260 volt-amperes

$$\frac{4260 \text{ volt-amperes}}{240 \text{ volts}} = 17.75 \text{ amperes per leg}$$

	Amperes per leg	
	A	B
Lighting and appliances	17.75	17.75
Heater, $1000 \text{ VA} \div 240 \text{ volt} =$	4.2	4.2
Fan, $200 \text{ VA} \div 120 \text{ volt} =$	1.7	
Dishwasher, $400 \text{ VA} \div 120 =$		3.3
Range, $7000 \text{ VA} \times .8 \div 240 =$	<u>23.3</u>	<u>23.3</u>
Totals	46.95	48.55

Based on the higher current calculated for either leg, a minimum 50-ampere supply cord is required.

For SI units: one square foot — 0.093 square meter; one foot — 0.3048 meter.

(c) **Optional Method of Calculation for Lighting and Appliance Load.** For mobile homes, the optional method for calculating lighting and appliance load shown in Section 220-30 and Table 220-30 shall be permitted.

#### 550-14. Interconnection of Multiple Section Mobile Home Units.

(a) **Fixed-type Wiring.** Approved and listed fixed-type wiring methods shall be used to join portions of a circuit which must be electrically joined which are located in adjacent sections of mobile homes after the home is installed on its support foundation. The circuit's junction shall be accessible for disassembly when the home is prepared for relocation.

(b) **Disconnecting Means.** Multiple section mobile homes not having permanently installed feeders, and which are to be moved from one location to another, shall be permitted to have disconnecting means with branch-circuit protective equipment in each unit when so located that after assembly or joining together of units, they shall not be interconnected on either the line side or the load side, except that the grounding means shall be electrically interconnected.

(FPN): Subsection (b) above applies to connection of previously constructed mobile homes where multiple feeder assemblies were allowed. The present Code does not permit more than one cord or feeder to a mobile home.

**550-15. Outdoor Outlets, Fixtures, Air-Cooling Equipment, Etc.**

(a) **Listed for Outdoor Use.** Outdoor fixtures and equipment shall be listed for outdoor use. Outdoor receptacle or convenience outlets shall be of a gasketed-cover type for use in wet locations.

(b) **Outside Heating and/or Air-Conditioning Equipment.** A mobile home provided with a branch circuit designed to energize heating and/or air-conditioning equipment located outside the mobile home, other than room air conditioners, shall have such branch-circuit conductors terminate in a listed outlet box, or disconnecting means, located on the outside of the mobile home. A label shall be permanently affixed adjacent to the outlet box and contain the following information:

This connection is for heating and/or air-conditioning equipment. The branch circuit is rated at not more than \_\_\_\_\_ amperes, at \_\_\_\_\_ volts, 60-Hertz, \_\_\_\_\_ conductor ampacity. A disconnecting means shall be located within sight of the equipment.

The correct voltage and ampere rating shall be given. The tag shall be not less than 0.020 inch (508 micrometers), etched brass, stainless steel, anodized or clad aluminum or equivalent. The tag shall not be less than 3 inches (76 mm) by 1¼ inches (44.5 mm) minimum size.

**B. Mobile Home Parks**

**550-21. Distribution System.** The mobile home park secondary electrical distribution system to mobile home lots shall be single-phase, 120/240 volts, nominal. For the purpose of Part B, where the park service exceeds 240 volts, nominal, transformers and secondary distribution panelboards shall be treated as services.

(FPN): See Table 550-22 for calculation of load.

**550-22. Calculated Load.**

(a) **Minimum Allowable Demand Factors.** Park electrical wiring systems shall be calculated (at 120/240 volts) on the larger of: (1) 16,000 volt-amperes for each mobile home lot, or (2) the load calculated in accordance with Section 550-13 for the largest typical mobile home that each lot will accept. It shall be permissible to compute the feeder or service load in accordance with Table 550-22. No demand factor shall be allowed for any other load, except as provided in this Code.

(b) **Adequate Feeder Capacity.** Mobile home lot feeder circuit conductors shall have adequate capacity for the loads supplied, and shall be rated at not less than 100 amperes at 120/240 volts.

**550-23. Mobile Home Service Equipment.**

(a) **Rating.** Mobile home service equipment shall be rated at not less than 100 amperes, and provision shall be made for connecting a mobile home feeder assembly by a permanent wiring method. Power outlets used as mobile home service equipment shall also be permitted to contain receptacles rated up to 50 amperes with appropriate overcurrent protection. Fifty-

**Table 550-22**  
**Demand Factors for Feeders and Service-Entrance Conductors**

Number of Mobile Homes	Demand Factor (Percent)
1	100
2	55
3	44
4	39
5	33
6	29
7-9	28
10-12	27
13-15	26
16-21	25
22-40	24
41-60	23
61 and over	22

ampere receptacles shall conform to the configuration shown in Figure 550-5 (c).

(FPN): Complete details on the 50-ampere attachment plug cap configuration can be found in American National Standard Dimensions of Caps, Plugs and Receptacles, ANSI C73.17-1972.

**(b) Additional Outside Electrical Equipment.** Mobile home service equipment shall also contain a means for connecting a mobile home accessory building or structure or additional electrical equipment located outside a mobile home by a fixed wiring method.

**(c) Additional Receptacles.** Additional receptacles shall be permitted for connection of electrical equipment located outside the mobile home, and all such 125-volt, single-phase, 15- and 20-ampere receptacles shall be protected by a listed ground-fault circuit-interrupter protection.

**(d) Location.** Mobile home service equipment shall be readily accessible and shall be located in sight from and not more than 30 feet (9.14 m) from the exterior wall of the mobile home it serves.

**(e) Mounting Height.** Mobile home disconnecting means shall be located not less than 2 feet (610 mm) above finished grade or working platform. The disconnecting means shall be so installed that the center of the grip of the operating handle, when in its highest position, will not be more than 6½ feet (1.98 m) above the finished grade or working platform.

**(f) Grounded.** Each mobile home service equipment shall be grounded in accordance with Article 250 for service equipment.

**550-24. Feeder.** Mobile home feeder conductors shall consist of a listed cord, factory-installed in accordance with Section 550-5(b), or a permanently installed feeder containing four continuous, insulated, color-coded conductors which shall be identified by the factory or field marking of the conductors in compliance with Section 310-12.

## ARTICLE 551 — RECREATIONAL VEHICLES AND RECREATIONAL VEHICLE PARKS

**551-1. Scope.** The provisions of this article cover the electrical conductors and equipment installed within or on recreational vehicles, the conductors that connect recreational vehicles to a supply of electricity, and the installation of equipment and devices related to electrical installations within a recreational vehicle park.

(FPN): For requirements on the installation of plumbing and heating systems in recreational vehicles, refer to Standard for Recreational Vehicles, NFPA 501C-1982 (ANSI).

**551-2. Definitions.** (See Article 100 for other definitions.)

**Air-Conditioning or Comfort-Cooling Equipment:** All of that equipment intended or installed for the purpose of processing the treatment of air so as to control simultaneously its temperature, humidity, cleanliness, and distribution to meet the requirements of the conditioned space.

**Appliance, Fixed:** An appliance which is fastened or otherwise secured at a specific location.

**Appliance, Portable:** An appliance which is actually moved or can easily be moved from one place to another in normal use.

(FPN): For the purpose of this article, the following major appliances other than built-in are considered portable if cord-connected: refrigerators, gas range equipment, clothes washers, dishwashers without booster heaters, or other similar appliances.

**Appliance, Stationary:** An appliance which is not easily moved from one place to another in normal use.

**Camping Trailer:** A vehicular portable unit mounted on wheels and constructed with collapsible partial side walls which fold for towing by another vehicle and unfold at the campsite to provide temporary living quarters for recreational, camping, or travel use. (See "Recreational Vehicle.")

**Converter:** A device which changes electrical energy from one form to another, as from alternating current to direct current.

**Dead Front:** (As applied to switches, circuit breakers, switchboards, and distribution panelboards.) So designed, constructed, and installed that no current-carrying parts are normally exposed on the front.

**Disconnecting Means:** The necessary equipment usually consisting of a circuit breaker or switch and fuses, and their accessories, located near the point of entrance of supply conductors in a recreational vehicle and intended to constitute the means of cutoff for the supply to that recreational vehicle.

Receptacles used as disconnecting means shall be accessible (as applied to wiring methods) and capable of interrupting their rated current without hazard to the operator.

**Distribution Panelboard:** A single panel or group of panel units designed for assembly in the form of a single panel; including buses, and with or without switches and/or automatic overcurrent protective devices for the control of light, heat, or power circuits of small individual as well as aggregate capacity; designed to be placed in a cabinet or cutout box placed in or against a wall or partition and accessible only from the front.



**Frame:** Chassis rail and any welded addition thereto of metal thickness of 16 MSG or greater.

**Low-Voltage:** An electromotive force rated nominal 24 volts, nominal, or less, supplied from a transformer, converter, or battery.

**Motor Home:** A vehicular unit designed to provide temporary living quarters for recreational, camping, or travel use built on or permanently attached to a self-propelled motor vehicle chassis or on a chassis cab or van which is an integral part of the completed vehicle. (See "Recreational Vehicle.")

**Power-Supply Assembly:** The conductors, including the grounding conductors, insulated from one another, the connectors, attachment plug caps, and all other fittings, grommets, or devices installed for the purpose of delivering energy from the source of electrical supply to the distribution panel within the recreational vehicle.

**Recreational Vehicle:** A vehicular-type unit primarily designed as temporary living quarters for recreational, camping, or travel use, which either has its own motive power or is mounted on or drawn by another vehicle. The basic entities are: travel trailer, camping trailer, truck camper, and motor home.

**Transformer:** A device, which when used, will raise or lower the voltage of alternating current of the original source.

**Travel Trailer:** A vehicular unit mounted on wheels, designed to provide temporary living quarters for recreational, camping, or travel use, of such size or weight as not to require special highway movement permits when drawn by a motorized vehicle, and with a living area of less than 220 square feet (20.44 sq m), excluding built-in equipment (such as wardrobes, closets, cabinets, kitchen units or fixtures) and bath and toilet rooms. (See "Recreational Vehicle.")

**Truck Camper:** A portable unit constructed to provide temporary living quarters for recreational, travel, or camping use, consisting of a roof, floor, and sides, designed to be loaded onto and unloaded from the bed of a pick-up truck. (See "Recreational Vehicle.")

#### **A: Recreational Vehicles**

**551-3. Other Articles.** Whenever the requirements of other articles of this Code and Article 551 differ, the requirements of Article 551 shall apply.

#### **551-4. General Requirements.**

(a) **Not Covered.** A recreational vehicle not used for the purposes as defined in Section 551-2 shall not be required to meet the provisions of Part A pertaining to the number or capacity of circuits required. It shall, however, meet all other applicable requirements of this article if the recreational vehicle is provided with an electrical installation intended to be energized from a 120- or 120/240-volt, nominal, ac power-supply system.

(b) **Systems.** This article covers battery and direct-current power (12-volt or less) systems, combination electrical systems, generator installations, and 120- or 120/240-volt, nominal, systems.

**551-5. Low-Voltage Systems.**

(a) **Low-Voltage Circuits.** Low-voltage circuits furnished and installed by the recreational vehicle manufacturer, other than those related to braking, are subject to this Code. Circuits supplying lights subject to federal or state regulations shall comply with applicable government regulations and this Code.

**(b) Low-Voltage Wiring.**

(1) Copper conductors shall be used for low-voltage circuits.

*Exception: Metal chassis or frame shall be permitted as the return path to the source of supply. Connections to the chassis or frame shall be made (1) in an accessible location, (2) by means of copper conductors and copper or copper alloy terminals of the solderless type identified for the size of wire used, and (3) mechanically secure.*

(2) Conductors shall conform to the requirements for Type HDT, SGT, SGR, or Type SXL, or shall have insulation in accordance with Table 310-13 or the equivalent. Conductor sizes No. 6 through 18 AWG or SAE shall be listed.

(FPN): See SAE Standard J1128-1975 for Types HDT and SXL, and SAE Standard J1127-1980 for Types SGT and SGR.

(3) Single-wire, low-voltage conductors shall be of the stranded type.

(4) All insulated low-voltage conductors shall be surface marked at intervals no greater than 4 feet (1.22 m) as follows:

- a. Listed conductors shall be marked as required by the listing agency.
- b. SAE conductors shall be marked with the name or logo of the manufacturer, specification designation, and wire gage.
- c. Other conductors shall be marked with the name or logo of the manufacturer, temperature rating, wire gage, conductor material, and insulation thickness.

**(c) Low-Voltage Wiring Methods.**

(1) Conductors shall be protected against physical damage and shall be secured. Where insulated conductors are clamped to the structure; the conductor insulation shall be supplemented by an additional wrap or layer of equivalent material, except that jacketed cables need not be so protected. Wiring shall be routed away from sharp edges, moving parts, or heat sources.

(2) Conductors shall be spliced or joined with splicing devices that provide a secure connection or by brazing, welding, or soldering with a fusible metal or alloy. Soldered splices shall first be so spliced or joined as to be mechanically and electrically secure without solder and then soldered. All splices, joints, and free ends of conductors shall be covered with an insulation equivalent to that on the conductors.

(3) Battery and direct-current circuits shall be physically separated by at least a 1/2-inch (12.7-mm) gap or other approved means from circuits of a different power source. Acceptable methods shall be by clamping, routing, or equivalent means which ensure permanent total separation. Where circuits of different power sources cross, the external jacket of the nonmetallic-sheathed cables shall be deemed adequate separation.

(4) Ground terminals shall be accessible for service. The surface on which ground terminals make contact shall be cleaned and free from oxide or paint, or shall be electrically connected through use of a cadmium, tin, or

zinc plated internal-external toothed lockwasher or locking terminals. Ground terminal attaching screws, rivets or bolts, nuts and lockwashers shall be cadmium, tin or zinc plated, except rivets shall be permitted to be unanodized aluminum when attaching to aluminum structures.

(5) The chassis-grounding terminal of the battery shall be bonded to the vehicle chassis with a minimum No. 8 AWG copper conductor or equivalent. In the event the power lead from the battery exceeds No. 8-AWG, then the bonding conductor shall be of an equal size.

(d) **Battery Installations.** Storage batteries subject to the provisions of this Code shall be securely attached to the vehicle and installed in an area vaportight to the interior and ventilated directly to the exterior of the vehicle. When batteries are installed in a compartment, the compartment shall be ventilated with openings having a minimum area of 1.7 square inches (1100 sq mm) at both the top and at the bottom. When compartment doors are equipped for ventilation the openings shall be within 1 inch (25.4 mm) of the top and bottom. Batteries shall not be installed in a compartment containing spark or flame producing equipment except that they shall be permitted to be installed in the engine generator compartment if the only charging source is from the engine generator.

(e) **Overcurrent Protection.**

(1) Low-voltage circuit wiring shall be protected by overcurrent protective devices rated not in excess of the ampacity of copper conductors, as follows:

Wire Size	Ampacity	Wire Type
18	6	Stranded only
16	8	Stranded only
14	15	Stranded or Solid
12	20	Stranded or Solid
10	30	Stranded or Solid

(2) Circuit breakers or fuses shall be of an approved type, including automotive types. Fuseholders shall be clearly marked with maximum fuse size and shall be protected against shorting and physical damage by a cover or equivalent means.

(FPN) For further information, see Society of Automotive Engineers (SAE) Standard for Electric Fuses (Cartridge Type), ANSI/SAE J554(b)-1981; Standard for Blade Type Electric Fuses, SAE J1284; and Underwriters Laboratories Inc. Standard for Automotive Glass Tube Fuses, UL 275-1978.

(3) Higher current-consuming, direct-current appliances such as pumps, compressors, heater blowers, and similar motor-driven appliances shall be installed in accordance with the manufacturer's instructions.

Motors which are controlled by automatic switching or by latching-type manual switches shall be protected in accordance with Section 430-32(c).

(4) The overcurrent protective device shall be installed in an accessible location on the vehicle within 18 inches (457 mm) of the point where the power supply connects to the vehicle circuits. If located outside the recreational vehicle, the device shall be protected against weather and physical damage.

*Exception: External low-voltage supply shall be permitted to be fused within 18 inches (457 mm) after entering the vehicle or after leaving a metal raceway.*

**(f) Switches.** Switches shall have a direct-current rating not less than the connected load.

**(g) Lighting Fixtures.** All low-voltage interior lighting fixtures shall be listed.

**(h) Cigarette Lighter Receptacles.** Twelve-volt receptacles that will accept and energize cigarette lighters shall be installed in a noncombustible outlet box or the assembly shall be identified by the manufacturer of the product as thermally protected.

#### **551-6. Combination Electrical Systems.**

**(a) General.** Vehicle wiring suitable for connection to a battery or direct-current supply source shall be permitted to be connected to a 120-volt source provided that the entire wiring system and equipment are rated and installed in full conformity with Part A requirements covering 120-volt electrical systems. Circuits fed from alternating-current transformers shall not supply direct-current appliances.

**(b) Voltage Converters (120-Volt Alternating Current to Low-Voltage Direct Current).** The 120-volt alternating current side of the voltage converter shall be wired in full conformity with Part A requirements for 120-volt electrical systems.

*Exception: Converters supplied as an integral part of a listed appliance shall not be subject to the above.*

All converters and transformers shall be listed for use in recreation vehicles and designed or equipped to provide over-temperature protection. To determine the converter rating the following formula shall be applied to the total connected load, including average battery charging rate, of all 12-volt equipment:

The first 20 amperes of load at 100 percent; plus

The second 20 amperes of load at 50 percent; plus

All load above 40 amperes at 25 percent.

*Exception: A low-voltage appliance which is controlled by a momentary switch (normally "open") which has no means for holding in the "closed" position shall not be considered as a "connected load" when determining the required converter rating. Momentarily energized appliances shall be limited to those used to prepare the vehicle for occupancy or travel.*

**(c) Bonding Voltage Converter Enclosures.** The noncurrent-carrying metal enclosure of the voltage converter shall be bonded to the frame of the vehicle with a No. 8 AWG copper conductor minimum or equivalent. The grounding conductor for the battery and the metal enclosure shall be permitted to be the same conductor.

**(d) Dual-Voltage Fixtures or Appliances.** Fixtures or appliances having both 120-volt and low-voltage connections shall be listed for dual voltage.

**(e) Autotransformers.** Autotransformers shall not be used.

**(f) Receptacles and Plug Caps.** Where a recreational vehicle is equipped with a 120-volt or 120/240-volt alternating-current system and/or a low-voltage system, receptacles and plug caps of the low-voltage system shall differ in configuration from those of the 120- or 120/240-volt system. When a

vehicle equipped with a battery or direct-current system has an external connection for low-voltage power, the receptacle shall have a configuration that will not accept 120-volt power.

#### **551-7. Generator Installations.**

(a) **Mounting.** Generators shall be mounted in such a manner as to be effectively bonded to the recreational vehicle chassis.

(b) **Generator Protection.** Equipment shall be installed to ensure that the current-carrying conductors from the engine generator and from an outside source are not connected to a vehicle circuit at the same time.

(c) **Installation of Storage Batteries and Generators.** Storage batteries and internal-combustion-driven generator units (subject to the provisions of this Code) shall be secured in place to avoid displacement from vibration and road shock.

(d) **Ventilation of Generator Compartments.** Compartments accommodating internal-combustion-driven generator units shall be provided with ventilation in accordance with instructions provided by the manufacturer of the generator unit.

(e) **Supply Conductors.** The supply conductors from the engine generator to the first termination on the vehicle shall be of the stranded type and be installed in listed flexible metal conduit. The point of first termination shall be in a (1) panelboard, (2) junction box with a blank cover, (3) junction box with a receptacle, or (4) receptacle assembly listed in conjunction with the generator.

The panelboard or junction box with a receptacle shall be installed within the vehicle's interior and within 18 inches (457 mm) of the compartment wall but not inside the compartment. A junction box with a blank cover shall be mounted on the compartment wall, and shall be permitted inside or outside the compartment. A receptacle assembly listed in conjunction with the generator shall be mounted in accordance with its listing. Overcurrent protection in accordance with Section 240-3 shall be provided for supply conductors as an integral part of a listed generator or shall be located within 18 inches (457 mm) of their point of entry into the vehicle.

(f) **Compartment Construction.** Generator compartments shall be lined with galvanized steel, not less than 26 MSG thick. Seams and joints shall be lapped, mechanically secured and made vaportight to the interior of the vehicle. Alternate materials and methods of construction shall be permitted to be used if they provide equivalent quality, strength, effectiveness, fire resistance, durability and safety. Fuel lines and exhaust systems shall not penetrate into the living area. Holes for electrical conduit, conductors or cables into the living area shall be sealed vaportight.

#### **551-8. 120- or 120/240-Volt, Nominal, Systems.**

(a) **General Requirements.** The electrical equipment and material of recreational vehicles indicated for connection to a wiring system rated 120 volts, nominal, 2-wire with ground, or a wiring system rated 120/240 volts, nominal, 3-wire with ground, shall be listed and installed in accordance with the requirements of Part A.

(b) **Materials and Equipment.** Electrical materials, devices, appliances, fittings, and other equipment installed, intended for use in, or attached to the recreational vehicle shall be listed. All products shall be used only in the

manner in which they have been tested and found suitable for the intended use.

(c) **Other Sources.** Other sources of ac power such as inverters or motor generators shall be listed for use in recreational vehicles and shall be installed in accordance with the terms of the listing. Other sources of ac power shall be wired in full conformity with the requirements in Part A of this article covering 120-volt electrical systems.

(d) **Alternate Source Restriction.** Transfer equipment, if not integral with the listed power source, shall be installed to ensure that the current-carrying conductors from other sources of ac power and from an outside source are not connected to the vehicle circuit at the same time.

(e) **Ground-Fault Circuit-Interrupter Protection.** The internal wiring of a recreational vehicle having only one 15- or 20-ampere branch circuit as permitted in Sections 551-10(a) and (b) shall have ground-fault circuit-interrupter protection for personnel. The ground-fault circuit-interrupter shall be installed at the point where the power supply assembly terminates within the recreational vehicle. Where a separable cord set is not employed, the ground-fault circuit-interrupter shall be permitted to be an integral part of the attachment plug of the power supply assembly. The ground-fault circuit-interrupter shall provide protection also under the conditions of an open grounded circuit conductor or interchanged circuit conductors.

#### 551-9. Receptacle Outlets Required.

(a) **Spacing.** Receptacle outlets shall be installed at wall spaces 2 feet (610 mm) wide or more so that no point along the floor line is more than 6 feet (1.83 m), measured horizontally, from an outlet in that space.

*Exception No. 1: Bath and hall areas.*

*Exception No. 2: Wall spaces occupied by kitchen cabinets, wardrobe cabinets, built-in furniture, behind doors which may open fully against a wall surface, or similar facilities.*

(b) **Location.** Receptacle outlets shall be installed:

(1) Adjacent to counter tops in the kitchen [at least one on each side of the sink if counter tops are on each side and are 12 inches (305 mm) or over in width].

(2) Adjacent to the refrigerator and gas range space, except when a gas-fired refrigerator or cooking appliance, requiring no external electrical connection, is factory-installed.

(3) Adjacent to counter top spaces of 12 inches (305 mm) or more in width which cannot be reached from a receptacle required in Section 551-9(b)(1) by a cord of 6 feet (1.83 m) without crossing a traffic area, cooking appliance, or sink.

(c) **Ground-Fault Circuit Protection.** Where provided, each 120-volt, single-phase, 15- or 20-ampere receptacle outlet shall have ground-fault circuit protection for personnel in the following locations:

(1) Adjacent to a bathroom lavatory. [The receptacle outlet shall be a minimum of 24 inches (610 mm) from the compartment floor.]

(2) Adjacent to any lavatory.

(3) In the area occupied by a toilet, toilet and/or shower, or toilet and tub-shower enclosure.

**(4) On the exterior of the vehicle.**

The receptacle outlet shall be permitted in a listed lighting fixture. A receptacle outlet shall not be installed in a tub or combination tub-shower compartment.

*Exception: Where ground-fault circuit-interrupter protection is provided in accordance with Section 551-8(e).*

**(d) Face-Up Position.** A receptacle shall not be installed in a face-up position in any counter top or similar horizontal surfaces within the living area.

**551-10. Branch Circuits Required.** Each recreational vehicle containing a 120-volt electrical system shall contain one of the following:

**(a) One 15-Ampere Circuit.** One 15-ampere circuit to supply lights, receptacles outlets and fixed appliances. Such recreational vehicles shall be equipped with one 15-ampere switch and fuse, or 15-ampere circuit breaker.

**(b) One 20-Ampere Circuit.** One 20-ampere circuit to supply lights, receptacle outlets and fixed appliances. Such recreational vehicles shall be equipped with one 20-ampere switch and fuse, or 20-ampere circuit breaker.

**(c) Two or More 15- or 20-Ampere Circuits.** Two or more 15- or 20-ampere circuits to supply lights, receptacle outlets and fixed appliances. Such recreational vehicles shall be equipped with a 30-ampere rated main power supply assembly.

(FPN): See Section 210-23(a) for permissible loads: See Section 551-13(c) for main disconnect and overcurrent protection requirements.

**(d) Power Supply Assembly.** A 40- or 50-ampere power supply assembly which shall be calculated in accordance with the following method:

**(1) Lighting.** If electric lighting is provided either directly or indirectly (through a voltage converter) by the 120-volt or 120/240-volt system, calculate lighting wattage at 3 volt-amperes per square foot using exterior dimensions (exclusive of hitch and cab) as follows:

Length (feet) × width (feet) × 3 = \_\_\_\_\_ lighting volt-amperes.

**(2) Small Appliance.** Number of circuits times 1,500 volt-amperes for each 20-ampere appliance receptacle circuit, e.g.,

Number of Circuits × 1,500 = \_\_\_\_\_ small appliance volt-amperes.

**(3) Total.** Lighting volt-amperes plus small appliance volt-amperes = \_\_\_\_\_ total volt-amperes.

**(4) First 3,000 total volt-amperes at 100 percent plus remainder at 35 percent = \_\_\_\_\_ volt-amperes to be divided by voltage to obtain current (amperes) per leg.**

Amperes per Leg	
A	B
_____	_____

Lighting and small appliance current (amperes) per leg (from D above) = \_\_\_\_\_

(5) Add nameplate amperes for motors and heater loads (exhaust fans, air conditioners\*, electric, gas, or oil heating\*). Also include anticipated loads in above categories when prewired outlets or circuits are installed for other than factory-installed major appliances.

\*Omit smaller of heating or air conditioning load, except include any motor common to both functions.

(6) Add 25 percent of amperes of largest motor in E = \_\_\_\_\_

(7) Add nameplate amperes of the following appliances. Include anticipated loads when prewired outlets or circuits are installed for other than factory-installed major appliances. When number of appliances is four or more, use 75 percent of total.

Disposal	_____	_____		
Water Heater	_____	_____		
Wall-Mounted Ovens	_____	_____		
Cooking Units	_____	_____		
<b>TOTAL</b>	_____	_____	=	_____

(8) Add amperes for free-standing range as distinguished from separate ovens and cooking units. Derive from following table by dividing volt-amperes by 240 volts.

Range	Nameplate Rating (watts)	Use (volt-amperes)
(Freestanding range as distinguished from separate oven and cooking units)	0 thru 10,000	80 percent of rating
	over 10,000 thru 12,500	8,000
	over 12,500 thru 13,500	8,400
	over 13,500 thru 14,500	8,800
	over 14,500 thru 15,500	9,200
	over 15,500 thru 16,500	9,600
	over 16,500 thru 17,500	10,000

**551-11. Branch-Circuit Protection.**

(a) **Rating.** The branch-circuit overcurrent devices shall be rated:

- (1) Not more than the circuit conductors; and
- (2) Not more than 150 percent of the rating of a single appliance rated 13.3 amperes or more and supplied by an individual branch circuit; but
- (3) Not more than the overcurrent protection size marked on an air conditioner or other motor-operated appliances.

(b) **Protection for Smaller Conductors.** A 20-ampere fuse or circuit breaker shall be permitted for protection for fixture leads, cords, or small appliances, and No. 14 tap conductors, not over 6 feet (1.83 m) long for recessed lighting fixtures.

(c) **15-Ampere Receptacle Considered Protected by 20 Amperes.** If more than one outlet or load is on a branch circuit, a 15-ampere receptacle shall be permitted to be protected by a 20-ampere fuse or circuit breaker.



**551-12. Power-Supply Assembly.**

(a) **15-Ampere Main Power-Supply Assembly.** Recreational vehicles wired in accordance with Section 551-10(a) shall use a listed 15-ampere, or larger, main power-supply assembly.

(b) **20-Ampere Main Power-Supply Assembly.** Recreational vehicles wired in accordance with Section 551-10(b) shall use a listed 20-ampere, or larger, main power-supply assembly.

(c) **30-Ampere Main Power-Supply Assembly.** Recreational vehicles wired in accordance with Section 551-10(c) shall use a listed 30-ampere, or larger, main power-supply assembly.

(d) **40- or 50-Ampere Power-Supply Assembly.** In accordance with Section 551-10(d), any recreational vehicle with a rating in excess of 30 amperes, 120 volts, shall use a listed 40-ampere or 50-ampere, 120/240-volt power-supply assembly.

*Exception No. 1: When the calculated load of the recreational vehicle exceeds 30 amperes, 120 volts, a second power-supply cord shall be permitted. Where a two-cord supply system is installed, they shall not be interconnected on either the line side or the load side. The grounding circuits and grounding means shall be electrically interconnected.*

*Exception No. 2: For a dual-supply source consisting of a generator and a power-supply cord, see Section 551-14.*

**551-13. Distribution Panelboard.**

(a) **Listed and Appropriately Rated.** A listed and appropriately rated distribution panelboard or other equipment specifically listed for the purpose shall be used. The grounded conductor termination bar shall be insulated as provided in Section 551-23(c); the grounding bar shall be attached to the metal enclosure of the panelboard or other approved grounding means.

(b) **Location.** The distribution panelboard shall be installed in a readily accessible location. Working clearance for the panelboard shall be no less than 24 inches (610 mm) wide and 30 inches (762 mm) deep.

*Exception: Where the panelboard cover is exposed to the inside aisle space, then one of the working clearance dimensions shall be permitted to be reduced to a minimum of 22 inches (559 mm). A panelboard is considered exposed where the panelboard cover is within 2 inches (50.8 mm) of the aisle's finished surface.*

(c) **Dead-Front Type.** The distribution panelboard shall be of the dead-front type and shall consist of one or more circuit breakers or Type S fuseholders. A main disconnecting means shall be provided where fuses are used or where more than two circuit breakers are employed. A main overcurrent protective device not exceeding the power-supply assembly rating shall be provided where more than two branch circuits are employed.

**551-14. Multiple Supply Source.**

(a) **Multiple Supply Sources.** Where a multiple supply system consisting of an alternate power source and a power supply cord is installed, the feeder from the generator shall be protected by an overcurrent protective device. Installation shall be in accordance with Sections 551-7(a) and (b) and 551-8.

**(b) Calculation of Loads.** Calculation of loads shall be in accordance with Section 551-10.

**(c) Multiple Supply Sources Capacity.** The multiple supply sources shall not be required to be of the same capacity.

**(d) Alternate Power Sources Exceeding 30 Amperes.** If an alternate power source exceeds 30 amperes, 120 volts, nominal, it shall be permissible to wire it as a 120-volt, nominal, system or a 120/240-volt, nominal, system, providing an overcurrent protective device of the proper rating is installed in the feeder.

**(e) Power-Supply Assembly Not Less than 30 Amperes.** The external power-supply assembly shall be permitted to be less than the calculated load but not less than 30 amperes and shall have overcurrent protection not greater than the capacity of the external power-supply assembly.

### **551-15. Means for Connecting to Power Supply.**

**(a) Assembly.** The power-supply assembly or assemblies shall be factory-supplied or factory-installed when of the permanently connected type as specified herein:

**(1) Separable.** Where a separable power-supply assembly consisting of a cord with a female connector and molded attachment plug cap is provided, the vehicle shall be equipped with a permanently mounted, flanged surface inlet (male-recessed-type motor-base receptacle) wired directly to the distribution panelboard by an approved wiring method. The attachment plug cap shall be of a listed type.

**(2) Permanently Connected.** Each power-supply assembly shall be connected directly to the terminals of the distribution panelboard or conductors within a junction box and provided with means to prevent strain from being transmitted to the terminals. The ampacity of the conductors between each junction box and the terminals of each distribution panelboard shall be at least equal to the ampacity of the power-supply cord. The supply end of the assembly shall be equipped with an attachment plug of the type described in Section 551-15(c). Where the cord passes through the walls or floors, it shall be protected by means of conduit and bushings or equivalent.

**(b) Cord.** The cord exposed usable length shall be measured from the point of entrance to the recreational vehicle or the face of the flanged surface inlet (motor-base attachment plug) to the face of the attachment plug at the supply end.

The cord exposed usable length, measured to the point of entry on the vehicle exterior, shall be a minimum of 23 feet (7.0 m) when the point of entrance is at the side of the vehicle, or shall be a minimum 28 feet (8.5 m) when the point of entrance is at the rear of the vehicle.

When the cord entrance into the vehicle is more than 3 feet (0.9 m) above the ground, the minimum cord lengths above shall be increased by the vertical distance of the cord entrance heights above 3 feet (0.9 m).

(FPN): See Section 551-15(e).

#### **(c) Attachment Plugs.**

**(1)** Recreational vehicles having only one 15-ampere branch circuit as permitted by Section 551-10(a) shall have an attachment plug which shall be 2-pole, 3-wire, grounding type, rated 15 amperes, 125 volts, conforming to the configuration shown in Figure 551-15(c).

(FPN): Complete details of this configuration can be found in American National Standard ANSI C73.11-1972.

(2) Recreational vehicles having only one 20-ampere branch circuit as permitted in Section 551-10(b) shall have an attachment plug which shall be 2-pole, 3-wire, grounding type, rated 20 amperes, 125 volts, conforming to the configuration shown in Figure 551-15(c).

(FPN): Complete details of this configuration can be found in American National Standard ANSI C73.12-1972.

(3) Recreational vehicles wired in accordance with Section 551-10(c) shall have an attachment plug which shall be 2-pole, 3-wire, grounding type, rated 30 amperes, 125 volts, conforming to the configuration shown in Figure 551-15(c) intended for use with units rated at 30 amperes, 125 volts.

(FPN): Complete details of this configuration can be found in American National Standard Dimensions of Caps, Plugs and Receptacles, ANSI C73.13-1972.

(4) Recreational vehicles having a power-supply assembly rated 40 amperes or 50 amperes as permitted by Section 551-10(d) shall have a 3-pole, 4-wire, grounding-type attachment plug rated 50 amperes, 125/250 volts, conforming to the configuration shown in Figure 551-15(c).

(FPN): Complete details of this configuration can be found in American National Standard Dimensions of Caps, Plugs and Receptacles, ANSI C73.17-1972.

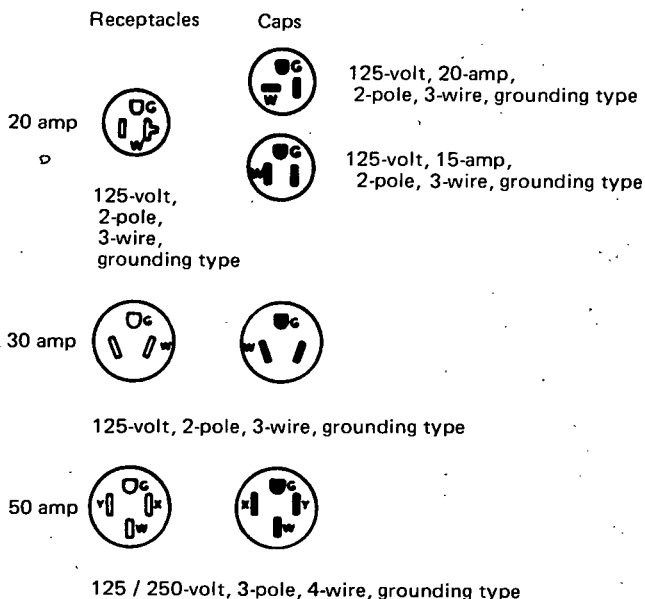

Figure 551-15(c). Configurations for grounding-type receptacles and attachment plug caps used for recreational vehicle supply cords and recreational vehicle lots.

**(d) Labeling at Electrical Entrance.** Each recreational vehicle shall have permanently affixed to the exterior skin at or near the point of entrance of the power-supply cord(s) a label 3 inches (76 mm) by 1¼ inches (44.5 mm) minimum size, made of etched, metal-stamped or embossed brass, stainless steel, anodized or alclad aluminum not less than 0.020 inch (508 micrometers) thick, or other suitable material [e.g., 0.005-inch (127-micrometers) plastic laminates], which reads, as appropriate, either:

“This connection is for 110-125 volt ac, 60 Hz \_\_\_\_\_ ampere supply,” or

“This connection is for 120/240 volt ac, 3-pole, 4-wire 60 Hz \_\_\_\_\_ ampere supply.”

The correct ampere rating shall be marked in the blank space.

**(e) Location.** The point of entrance of a power-supply assembly shall be located within 15 feet (4.57 m) of the rear, on the left (road) side or at the rear, left of the longitudinal center of the vehicle, within 18 inches (457 mm) of the outside wall.

*Exception: A recreational vehicle equipped with only a listed flexible drain system or a side-vent drain system shall be permitted to have the electrical point of entrance located on either side provided the drain(s) for the plumbing system is (are) located on the same side.*

#### 551-16. Wiring Methods.

**(a) Wiring Systems.** Rigid metal conduit, intermediate metal conduit, electrical metallic tubing, rigid nonmetallic conduit, flexible metal conduit, metal-clad cable, Type AC cable, and nonmetallic-sheathed cable shall be permitted. An equipment grounding means shall be provided in accordance with Section 250-91.

**(b) Conduit.** Where rigid metal conduit or intermediate metal conduit is terminated at an enclosure with a locknut and bushing connection, two locknuts shall be provided, one inside and one outside of the enclosure. All cut ends of conduit shall be reamed or otherwise finished to remove rough edges.

**(c) Nonmetallic Boxes.** Nonmetallic boxes shall be acceptable only with nonmetallic-sheathed cable or rigid and nonmetallic conduit.

**(d) Boxes.** In walls and ceilings constructed of wood or other combustible material, boxes and fittings shall be flush with the finished surface or project therefrom.

**(e) Mounting.** Wall and ceiling boxes shall be mounted in accordance with Article 370.

*Exception No. 1: Snap-in type boxes or boxes provided with special wall or ceiling brackets that securely fasten boxes in walls or ceilings shall be permitted.*

*Exception No. 2: A wooden plate providing a 1½-inch (38-mm) minimum width backing around the box and of a thickness of ½-inch (12.7 mm) or greater (actual) glued to the wall panel shall be considered as approved means for mounting outlet boxes.*

**(f) Sheath Armor.** The sheath of nonmetallic-sheathed cable, metal-clad cable and Type AC cable shall be continuous between outlet boxes and other enclosures.

**(g) Protected.** Metal-clad, Type AC, or nonmetallic-sheathed cables shall be permitted to pass through the centers of the wide side of 2-inch by 4-inch studs. However, they shall be protected where they pass through 2-inch by 2-inch studs or at other studs or frames where the cable would be less than 1½ inches (38 mm) from the inside or outside surface. Steel plates on each side of the cable, or a steel tube, with not less than No. 16 MSG wall thickness, shall be installed to protect the cable. These plates or tubes shall be securely held in place.

**(h) Bends.** No bend shall have a radius of less than five times the cable diameter.

**(i) Cable Supports.** When connected with cable connectors or clamps, cables shall be supported within 12 inches (305 mm) of outlet boxes, distribution panelboards, and splice boxes on appliances. Supports shall be provided every 4½ feet (1.37 m) at other places.

**(j) Nonmetallic Box Without Cable Clamps.** Nonmetallic-sheathed cables shall be supported within 8 inches (203 mm) of a nonmetallic outlet box without cable clamps.

*Exception: Where wiring devices with integral enclosures are employed with a loop of extra cable to permit future replacement of the device, the cable loop shall be considered as an integral portion of the device.*

**(k) Physical Damage.** Where subject to physical damage, exposed non-metallic cable shall be protected by covering boards, guard strips, or raceways.

**(l) Metal Faceplates.** Metal faceplates shall be of ferrous metal not less than 0.030 inch (762 micrometers) in thickness or of nonferrous metal not less than 0.040 inch (1.02 mm) in thickness. Nonmetallic faceplates shall be listed.

**(m) Metal Faceplates Effectively Grounded.** Where metal faceplates are used, they shall be effectively grounded.

**(n) Moisture or Physical Damage.** Where outdoor or underchassis wiring is 120 volts, nominal, or over and is exposed to moisture or physical damage, the wiring shall be protected by rigid metal conduit, intermediate metal conduit, or by electrical metallic tubing or rigid nonmetallic conduit that is closely routed against frames and equipment enclosures.

**(o) Component Interconnections.** Fittings and connectors which are intended to be concealed at the time of assembly shall be listed and identified for the interconnection of building components. Such fittings and connectors shall be equal to the wiring method employed in insulation, temperature rise, fault-current withstanding, and shall be capable of enduring the vibration and shock occurring in recreational vehicles.

**(p) Method of Connecting Expandable Units.**

**(1)** That portion of a branch circuit that is installed in an expandable unit shall be permitted to be connected to the portion of the branch circuit in the main body of the vehicle by means of an attachment plug and cord listed for hard usage. The cord and its connections shall conform to all provisions of Article 400 and shall be considered as a permitted use under Section 400-7.

*Exception: Where the attachment plug and cord are located within the vehicle's interior, use of plastic thermoset or elastomer parallel cords Type SPT-3, SP-3 or SPE shall be permitted.*

(2) If the receptacle provided for connection of the cord to the main circuit is located on the outside of the vehicle it shall be protected with a ground-fault circuit-interrupter for personnel and be listed for wet locations. A cord located on the outside of a vehicle shall be identified for outdoor use.

(3) Unless removable or stored within the vehicle interior, the cord assembly shall have permanent provisions for protection against corrosion and mechanical damage while the vehicle is in transit.

(4) The cord shall be installed so as not to permit exposed live attachment plug pins.

(q) **Prewiring for Air Conditioning Installation.** Prewiring installed for the purpose of facilitating future air-conditioning installation shall conform to the following and other applicable portions of this article. The circuit shall serve no other purpose.

(1) An overcurrent protective device with a rating compatible with the circuit conductors shall be installed in the distribution panelboard and wiring connections completed.

(2) The load end of the circuit shall terminate in a junction box with a blank cover. The free ends of the conductors shall be adequately capped or taped.

(3) A label conforming to Section 551-15(d) shall be placed on or adjacent to the junction box and shall read:

AIR-CONDITIONING CIRCUIT. THIS  
CONNECTION IS FOR AIR CONDITIONERS  
RATED 110-125 VOLT AC, 60 HZ 2  
AMPERES MAXIMUM. DO NOT EXCEED  
CIRCUIT RATING.

An ampere rating, not to exceed 80 percent of the circuit rating, shall be legibly marked in the blank space.

(r) **Prewiring for Generator Installation.** Prewiring installed for the purpose of facilitating future generator installation shall conform to the following and other applicable portions of this article.

(1) Circuit conductors shall be appropriately sized in relation to the anticipated load and shall be protected by an overcurrent device in accordance with their ampacities.

(2) Where junction boxes are utilized at the circuit originating and/or terminus points, free ends of the conductors shall be adequately capped or taped.

(3) When devices such as receptacle outlet, transfer switch, etc., are installed, the installation shall be complete including circuit conductor connections. All devices shall be listed and appropriately rated.

(4) A label conforming to Section 551-15(d) shall be placed on the cover of each junction box containing incomplete circuitry and shall read, as appropriate, either:

GENERATOR CIRCUIT. THIS CONNECTION IS FOR GENERATORS RATED 110-125 VOLT AC, 60 HZ \_\_\_\_\_ AMPERES MAXIMUM.

OR

GENERATOR CIRCUIT. THIS CONNECTION IS FOR GENERATORS RATED 120/240 VOLT AC, 60 HZ \_\_\_\_\_ AMPERES MAXIMUM.

The correct ampere rating shall be legibly marked in the blank space.

#### 551-17. Conductors and Boxes.

(a) **Maximum Number of Conductors.** The maximum number of conductors permitted in boxes shall be in accordance with Section 370-6.

(b) **Free Conductor at Each Box.** At least 4 inches (102 mm) of free conductor shall be left at each box except where conductors are intended to loop without joints.

551-18. **Grounded Conductors.** The identification of grounded conductors shall be in accordance with Section 200-6.

551-19. **Connection of Terminals and Splices.** Conductor splices and connections at terminals shall be in accordance with Section 110-14. If splices of the equipment grounding conductor in nonmetallic-sheathed cable are made in boxes containing devices, the splices shall be insulated.

551-20. **Switches.** Switches shall be rated as follows:

(a) **Lighting Circuits.** For lighting circuits, switches shall be rated not less than 10 amperes, 120-125 volts and in no case less than the connected load.

(b) **Motors or Other Loads.** For motors or other loads, switches shall have ampere or horsepower ratings, or both, adequate for loads controlled. (An ac general-use snap switch shall be permitted to control a motor 2 horsepower or less with full-load current not over 80 percent of the switch ampere rating.)

551-21. **Receptacles.** All receptacle outlets shall be: (1) of the grounding type, and (2) installed in accordance with Sections 210-7 and 210-21.

#### 551-22. Lighting Fixtures.

(a) **General.** Any combustible wall or ceiling finish exposed between the edge of a fixture canopy, or pan and the outlet box, shall be covered with noncombustible material or a material identified for the purpose.

(b) **Shower Fixtures.** If a lighting fixture is provided over a bathtub or in a shower stall, it shall be of the enclosed and gasketed type and listed for the type of installation, and shall be ground-fault circuit-interrupter protected if rated at 120 volts, nominal.

The switch for shower lighting fixtures and exhaust fans, located over a tub or in a shower stall, shall be located outside the tub or shower space.

(c) **Outdoor Outlets, Fixtures, Air-Cooling Equipment, Etc.** Outdoor fixtures and other equipment shall be listed for outdoor use.

551-23. **Grounding.** (See also Section 551-25 on bonding of noncurrent-carrying metal parts.)

(a) **Power-Supply Grounding.** The grounding conductor in the supply cord or feeder shall be connected to the grounding bus or other approved grounding means in the distribution panelboard.

(b) **Distribution Panelboard.** The distribution panelboard shall have a grounding bus with sufficient terminals for all grounding conductors or other approved grounding means.

(c) **Insulated Neutral.**

(1) The grounded circuit conductor (neutral) shall be insulated from the equipment grounding conductors and from equipment enclosures and other grounded parts. The grounded (neutral) circuit terminals in the distribution panelboard and in ranges, clothes dryers, counter-mounted cooking units, and wall-mounted ovens shall be insulated from the equipment enclosure. Bonding screws, straps, or buses in the distribution panel board or in appliances shall be removed and discarded.

(2) Connection of electric ranges and electric clothes dryers utilizing a grounded (neutral) conductor, if cord-connected, shall be made with 4-conductor cord and 3-pole, 4-wire, grounding-type plug caps and receptacles.

#### 551-24. Interior Equipment Grounding.

(a) **Exposed Metal Parts.** In the electrical system, all exposed metal parts, enclosures, frames, lighting fixture canopies, etc., shall be effectively bonded to the grounding terminals or enclosure of the distribution panelboard.

(b) **Equipment Grounding Conductors.** Bare wires, green-colored wires, or green wires with yellow stripe(s) shall be used for equipment grounding conductors only.

(c) **Grounding of Electrical Equipment.** Where grounding of electrical equipment is specified, it shall be permitted as follows:

(1) Connection of metal raceway (conduit or electrical metallic tubing), the sheath of metal-clad cable, or the armor of Type AC cable to metallic outlet boxes.

(2) A connection between the one or more equipment grounding conductors and a metal box by means of a grounding screw, which shall be used for no other purpose, or a listed grounding device.

(3) The equipment grounding conductor in nonmetallic-sheathed cable shall be permitted to be secured under a screw threaded into the fixture canopy other than a mounting screw or cover screw, or attached to a listed grounding means (plate) in a nonmetallic outlet box for fixture mounting (grounding means shall also be permitted for fixture attachment screws).

(d) **Grounding Connection in Nonmetallic Box.** A connection between the one or more grounding conductors brought into a nonmetallic outlet box shall be so arranged that a connection can be made to any fitting or device in that box that requires grounding.

(e) **Grounding Continuity.** Where more than one equipment grounding conductor of a branch circuit enters a box, all such conductors shall be in good electrical contact with each other, and the arrangement shall be such that the disconnection or removal of a receptacle, fixture, or other device fed from the box will not interfere with or interrupt the grounding continuity.

(f) **Cord-Connected Appliances.** Cord-connected appliances, such as washing machines, clothes dryers, refrigerators, and the electrical system of



gas ranges, etc., shall be grounded by means of an approved cord with equipment grounding conductor and grounding-type attachment plug.

#### **551-25. Bonding of Noncurrent-Carrying Metal Parts.**

(a) **Required Bonding.** All exposed noncurrent-carrying metal parts that may become energized shall be effectively bonded to the grounding terminal or enclosure of the distribution panelboard.

(b) **Bonding Chassis.** A bonding conductor shall be connected between any distribution panelboard and an accessible terminal on the chassis. Aluminum or copper-clad aluminum conductors shall not be used for bonding if such conductors or their terminals are exposed to corrosive elements.

*Exception: Any recreational vehicle which employs a unitized metal chassis-frame construction to which the distribution panelboard is securely fastened with a bolt(s) and nut(s) or by welding or riveting shall be considered to be bonded.*

(c) **Bonding Conductor Requirements.** Grounding terminals shall be of the solderless type and listed as pressure terminal connectors recognized for the wire size used. The bonding conductor shall be solid or stranded, insulated or bare, and shall be No. 8 copper minimum, or equal.

(d) **Metallic Roof and Exterior Bonding.** The metal roof and exterior covering shall be considered bonded where:

(1) The metal panels overlap one another and are securely attached to the wood or metal frame parts by metal fasteners, and

(2) The lower panel of the metal exterior covering is secured by metal fasteners at each cross member of the chassis, or the lower panel is bonded to the chassis by a metal strap.

(e) **Gas, Water, and Waste Pipe Bonding.** The gas, water, and waste pipes shall be considered grounded if they are bonded to the chassis.

(FPN): See Section 551-25(b) for chassis bonding.

(f) **Furnace and Metal Air Duct Bonding.** Furnace and metal circulating air ducts shall be bonded.

**551-26. Appliance Accessibility and Fastening.** Every appliance shall be accessible for inspection, service, repair, and replacement without removal of permanent construction. Means shall be provided to securely fasten appliances in place when the recreational vehicle is in transit.

**551-27. Factory Tests (Electrical).** Each recreational vehicle shall be subjected to the following tests:

(a) **Circuits of 120 Volts or 120/240 Volts.** Each recreational vehicle designed with a 120-volt or a 120/240-volt electrical system shall withstand the applied potential without electrical breakdown of a 1-minute, 900-volt dielectric strength test, or a 1-second, 1080-volt dielectric strength test, with all switches closed, between current-carrying conductors, including neutral, and the recreational vehicle ground. During the test, all switches and other controls shall be in the "on" position. Fixtures and permanently installed appliances shall not be required to withstand this test.

Each recreational vehicle shall be subjected to: (1) a continuity test to assure that all metallic parts are properly bonded; (2) operational tests to

demonstrate that all equipment is properly connected and in working order; and (3) polarity checks to determine that connections have been properly made.

**(b) Low-Voltage Circuits.** Low-voltage circuit conductors in each recreational vehicle shall withstand the applied potential without electrical breakdown of a 1-minute, 500-volt or a 1-second, 600-volt dielectric strength test. The potential shall be applied between live and grounded conductors.

The test shall be permitted on running light circuits before the lights are installed provided the vehicle's outer covering and interior cabinetry has been secured. The braking circuit shall be permitted to be tested before being connected to the brakes, provided the wiring has been completely secured.

## B. Recreational Vehicle Parks

### 551-41. Definitions.

**Power-Supply Assembly:** The conductors, including the grounding conductors, insulated from one another, the connectors, attachment plug caps, and all other fittings, grommets, or devices installed for the purpose of delivering energy from the source of electrical supply to the distribution panelboard within the recreational vehicle.

**Recreational Vehicle Park:** A plot of land upon which two or more recreational vehicle sites are located, established, or maintained for occupancy by recreational vehicles of the general public as temporary living quarters for recreation or vacation purposes.

**Recreational Vehicle Site:** A plot of ground within a recreational vehicle park intended for the accommodation of either a recreational vehicle, tent, or other individual camping unit on a temporary basis.

**Recreational Vehicle Site Feeder Circuit Conductors:** The conductors from the park service equipment to the recreational vehicle site supply equipment.

**Recreational Vehicle Site Supply Equipment:** The necessary equipment, usually a power outlet, consisting of a circuit breaker or switch and fuse and their accessories, located near the point of entrance of supply conductors to a recreational vehicle site and intended to constitute the disconnecting means for the supply to that site.

**Recreational Vehicle Stand:** That area of a recreational vehicle site intended for the placement of a recreational vehicle.

**551-42. Type Receptacles Provided.** Every recreational vehicle site with electrical supply shall be equipped with at least one 15- or 20-ampere, 125-volt receptacle. A minimum of 75 percent of all recreational vehicle sites with electrical supply shall each be equipped with a 30-ampere, 125-volt receptacle conforming to Figure 551-15(c). This supply shall be permitted to include additional receptacle configurations conforming to Section 551-52. The remainder of all recreational vehicle sites with electrical supply shall be equipped with one or more of the receptacle configurations conforming to Section 551-52.

All 15- and 20-ampere, 125-volt receptacles shall have listed ground-fault circuit-interrupter protection for personnel. Additional receptacles shall be permitted, for the connection of electrical equipment outside the recreational vehicle within the recreational vehicle park, and all such 125-volt, single-

phase, 15- and 20-ampere receptacles shall have ground-fault circuit-interrupter protection for personnel.

**551-43. Distribution System.** The recreational vehicle park secondary electrical distribution system to recreational vehicle sites shall be derived from a single-phase 120/240-volt, 3-wire system.

**551-44. Calculated Load.**

(a) **Basis of Calculations.** Electrical service and feeders shall be calculated on the basis of not less than 3,600 volt-amperes per site equipped with both 20-ampere and 30-ampere supply facilities and 2,400 volt-amperes per site equipped with only 20-ampere supply facilities. The demand factors set forth in Table 551-44 shall be the minimum allowable demand factors that shall be permitted in calculating load for service and feeders.

**Table 551-44**  
**Demand Factors for Feeders and Service-Entrance Conductors for Park Sites**

Number of Recreational Vehicle Sites	Demand Factor (percent)	Number of Recreational Vehicle Sites	Demand Factor (percent)
1	100	10-12	47
2	100	13-15	45
3	100	16-18	44
4	89	19-21	42
5	71	22-40	40
6	63	41-100	39
7-9	53	101 plus	37

(b) **Transformers and Secondary Distribution Panelboards.** For the purpose of this Code, where the park service exceeds 240 volts, transformers and secondary distribution panelboards shall be treated as services.

(c) **Demand Factors.** The demand factor for a given number of sites shall apply to all sites indicated. For example: twenty sites calculated at 42 percent of 3,600 volt-amperes result in a permissible demand of 1512 volt-amperes per site or a total of 30,240 volt-amperes for twenty sites.

(FPN): These demand factors may be inadequate in areas of extreme hot or cold temperature with loaded circuits for heating or air conditioning.

(d) **Feeder Circuit Capacity.** Recreational vehicle site feeder circuit conductors shall have adequate ampacity for the loads supplied, and shall be rated at not less than 30 amperes.

(FPN): Due to the long circuit lengths typical in most recreational vehicle parks, feeder conductor sizes found in ampacity tables of Article 310 may be inadequate to maintain the voltage regulation suggested in the Fine Print Note to Section 210-19. Total circuit voltage drop is a summation of the voltage drops of each serial circuit segment, where the load for each segment is calculated using the load that segment sees and the demand factors of Section 551-44(a).

**551-45. Overcurrent Protection.** Overcurrent protection shall be provided in accordance with Article 240.

**551-46. Grounding.** All electrical equipment and installations in recreational vehicle parks shall be grounded as required by Article 250.

**551-47. Recreational Vehicle Site Supply Equipment.**

(a) **Location.** Where provided, the recreational vehicle site electrical supply equipment shall be located on the left (road) side of the parked vehicle, on a line which is 9 feet (2.74 m),  $\pm$  1 foot (0.3 m), from the longitudinal centerline of the stand and shall be located at any point on this line from the rear of the stand to 15 feet (4.57 m) forward of the rear of the stand.

(b) **Disconnecting Means.** A disconnecting switch or circuit breaker shall be provided in the site supply equipment for disconnecting the power supply to the recreational vehicle.

(c) **Access.** All site supply equipment shall be accessible by an unobstructed entrance or passageway not less than 2 feet (610 mm) wide and 6½ feet (1.98 m) high.

(d) **Mounting Height.** Site supply equipment shall be located not less than 2 feet (610 mm) nor more than 6½ feet (1.98 m) above the ground.

(e) **Working Space.** Sufficient space shall be provided and maintained about all electric equipment to permit ready and safe operation, in accordance with Section 110-16.

**551-48. Grounding, Recreational Vehicle Site Supply Equipment.**

(a) **Exposed Noncurrent-Carrying Metal Parts.** Exposed noncurrent-carrying metal parts of fixed equipment, metal boxes, cabinets, and fittings, which are not electrically connected to grounded equipment, shall be grounded by a continuous equipment grounding conductor run with the circuit conductors from the service equipment or from the transformer of a secondary distribution system. Equipment grounding conductors shall be sized in accordance with Section 250-95.

(b) **Secondary Distribution System.** Each secondary distribution system shall be grounded at the transformer.

(c) **Neutral Conductor Not to Be Used as an Equipment Ground.** The neutral conductor shall not be used as an equipment ground for recreational vehicles or equipment within the recreational vehicle park.

(d) **No Connection on the Load Side.** No connection to a grounding electrode shall be made to the neutral conductor on the load side of the service disconnecting means or transformer distribution panelboard.

**551-49. Protection of Outdoor Equipment.**

(a) **Wet Locations.** All switches, circuit breakers, receptacles, control equipment, and metering devices located in wet locations or outside of a building shall be rainproof equipment.

(b) **Meters.** If secondary meters are installed, meter sockets without meters installed shall be blanked-off with an approved blanking plate.

**551-50. Clearance for Overhead Conductors.** Open conductors of not over 600 volts, nominal, shall have a vertical clearance of not less than 18 feet (5.49 m) and a horizontal clearance of not less than 3 feet (914 mm) in all areas subject to recreational vehicle movement. In all other areas, clearances shall conform to Sections 225-18 and 225-19.

(FPN): For clearances of conductors over 600 volts, nominal, see National Electrical Safety Code, ANSI C2-1984.

**551-51. Underground Service, Feeder, Branch-Circuit and Recreational Vehicle Site Feeder Circuit Conductors.**

(a) **General.** All direct-burial conductors, including the equipment grounding conductor if of aluminum, shall be insulated and identified for the use. All conductors shall be continuous from fitting to fitting. All splices and taps shall be made in approved junction boxes or by use of material listed and identified for the purpose.

(b) **Protection Against Physical Damage.** Where underground conductors enter or leave a building or trench, they shall be protected against physical damage by rigid metal conduit, intermediate metal conduit, rigid nonmetallic conduit Schedule 80, electrical metallic tubing, or other approved mechanical means, extending a minimum of 18 inches (457 mm) into the trench from the finished grade.

(FPN): See Section 300-5 and Article 339 for conductors or Type UF cable used underground or in direct burial in earth.

**551-52. Receptacles.** A receptacle to supply electric power to a recreational vehicle shall be one of the configurations shown in Figure 551-15(c) in the following ratings:

(a) **50 Ampere.** 125/250 volts, 50-ampere, 3-pole, 4-wire, grounding type for 120/240-volt systems.

(b) **30 Ampere.** 125-volt, 30-ampere, 2-pole, 3-wire, grounding type for 120-volt systems.

(c) **20 Ampere.** 125-volt, 20-ampere, 2-pole, 3-wire, grounding type for 120-volt systems.

(FPN): Complete details of these configurations can be found in American National Standard Dimensions of Caps, Plugs and Receptacles, ANSI C73.17-1972; ANSI C73.13-1972; and C73.12-1972.

## ARTICLE 553 — FLOATING BUILDINGS

### A. General

**553-1. Scope.** This article covers wiring, services, feeders, and grounding for floating buildings.

#### 553-2. Definition.

**Floating Building:** A building unit as defined in Article 100, which floats on water, is moored in a permanent location, and has a premises wiring system served through connection by permanent wiring to an electricity supply system not located on the premises.

**553-3. Application of Other Articles.** Wiring for floating buildings shall comply with the applicable provisions of other articles of this Code, except as modified by this article.

## B. Services and Feeders

**553-4. Location of Service Equipment.** The service equipment for a floating building shall be located adjacent to, but not in or on, the building.

**553-5. Service Conductors.** One set of service conductors shall be permitted to serve more than one set of service equipment.

**553-6. Feeder Conductors.** Each floating building shall be supplied by a single set of feeder conductors from its service equipment.

*Exception: Where the floating building has multiple occupancy, each occupant shall be permitted to be supplied by a single set of feeder conductors extended from the occupant's service equipment to the occupant's panelboard.*

**553-7. Installation of Services and Feeders.**

(a) **Flexibility.** Flexibility of the wiring system shall be maintained between floating buildings and the supply conductors. All wiring shall be so installed that motion of the water surface and changes in the water level will not result in unsafe conditions.

(b) **Wiring Methods.** Liquidtight flexible metal conduit with approved fittings shall be permitted for feeders and where flexible connections are required for services.

(FPN): See Sections 555-1 and 555-6.

## C. Grounding

**553-8. General Requirements.** Grounding of both electrical and nonelectrical parts in a floating building shall be through connection to a grounding bus in the building panelboard. The grounding bus shall be grounded through a green-colored insulated equipment grounding conductor run with the feeder conductors and connected to a grounding terminal in the service equipment. The grounding terminal in the service equipment shall be grounded by connection through a green insulated grounding electrode conductor to a grounding electrode on shore.

**553-9. Insulated Neutral.** The grounded circuit conductor (neutral) shall be a white insulated conductor. The neutral conductor shall be connected to the equipment grounding terminal in the service equipment and, except for that connection, it shall be insulated from the equipment grounding conductors, equipment enclosures, and all other grounded parts. The neutral circuit terminals in the panelboard and in ranges, clothes dryers, counter-mounted cooking units, and the like, shall be insulated from the enclosures.

**553-10. Equipment Grounding.**

(a) **Electrical Systems.** All enclosures and exposed metal parts of electrical systems shall be bonded to the grounding bus.

(b) **Cord-Connected Appliances.** Where required to be grounded, cord-connected appliances shall be grounded by means of an equipment grounding conductor in the cord and a grounding-type attachment plug.

**553-11. Bonding of Noncurrent-Carrying Metal Parts.** All metal parts in contact with the water, all metal piping, and all noncurrent-carrying metal

parts that may become energized, shall be bonded to the grounding bus in the panelboard.

## ARTICLE 555 — MARINAS AND BOATYARDS

**555-1. Scope.** This article covers the installation of wiring and equipment in the areas comprising fixed or floating piers, wharfs, docks, and other areas in marinas, boatyards, boat basins, and similar establishments that are used, or intended for use, for the purpose of repair, berthing, launching, storage, or fueling of small craft and the moorage of floating buildings.

**555-2. Application of Other Articles.** Wiring and equipment for marinas and boatyards shall comply with this article and also with the applicable provisions of other articles of this Code.

(FPN): See fine print notes following Sections 210-19(a) and 215-2(b) for voltage drop on branch circuits and feeders respectively.

(FPN): For disconnection of auxiliary power from boats, see Pleasure and Commercial Motor Craft, NFPA 302-1984 (ANSI).

**555-3. Receptacles.** Where shore power is supplied, those accommodations for boats 20 feet (6.1 m) or less in length shall be equipped with shore-power receptacles of a locking and grounding type rated at not less than 20 amperes.

Where shore power is supplied to accommodations for boats longer than 20 feet (6.1 m) in length, shore-power receptacles of a locking and grounding type rated at 30 amperes or more shall be provided.

Fifteen- and 20-ampere, single-phase, 125-volt receptacles other than those supplying shore power to boats located at piers, wharfs, and other locations shall be protected by ground-fault circuit-interrupters.

(FPN): For various configurations and ratings of locking- and grounding-type receptacles and caps, see Dimensions of Caps, Plugs, and Receptacles, ANSI C73-1972, and Supplement ANSI C73a-1980.

(FPN): For locking- and grounding-type receptacles for auxiliary power to boats; see Marinas and Boatyards, NFPA 303-1984 (ANSI).

(FPN): In locating receptacles consideration should be given to the maximum tide level and wave action.

**555-4. Branch Circuits.** Each single receptacle that supplies shore power to boats shall be supplied from a power outlet or panelboard by an individual or multiwire branch circuit of the voltage class and rating corresponding to the rating of the receptacle.

**555-5. Feeders and Services.** The load for each ungrounded feeder and service conductor supplying receptacles that supply shore power for boats shall be calculated as follows:

For 1-4 receptacles	100%	of the sum of the	rating of the	receptacles				
For 5-8	90%	"	"	"	"	"	"	"
For 9-14	80%	"	"	"	"	"	"	"
For 15-30	70%	"	"	"	"	"	"	"
For 31-40	60%	"	"	"	"	"	"	"
For 41-50	50%	"	"	"	"	"	"	"
For 51-70	40%	"	"	"	"	"	"	"
For 71-100	30%	"	"	"	"	"	"	"
For 101 plus	20%	"	"	"	"	"	"	"

(FPN): These demand factors may be inadequate in areas of extreme hot or cold temperature with loaded circuits for heating, air-conditioning, or refrigerating equipment.

**555-6. Wiring Methods.** The wiring method shall be one or more of the following identified as suitable for use where exposed to the weather or water: (1) rigid nonmetallic conduit; (2) mineral-insulated, metal-sheathed cable; (3) nonmetallic cable; (4) corrosion-resistant rigid metal conduit; (5) corrosion-resistant intermediate metal conduit; (6) underground wiring that complies with the requirements of Chapter 3 of this Code; (7) Type MC cable.

*Exception No. 1: Where flexibility is required, other types identified for the purpose.*

*Exception No. 2: Open wiring shall be permitted by special permission.*

(FPN): In granting special permission, major factors include possible contact of open wires with masts, cranes, or similar structures or equipment.

(FPN): For further information on wiring methods for various locations, see Marinas and Boatyards, NFPA 303-1984 (ANSI).

### 555-7. Grounding.

**(a) Equipment to Be Grounded.** The following items shall be connected to an equipment grounding conductor run with the circuit conductors in a raceway or cable:

- (1) Boxes, cabinets, and all other metal enclosures.
- (2) Metal frames of utilization equipment.
- (3) Grounding terminals of grounding-type receptacles.

**(b) Type of Equipment Grounding Conductor.** The equipment grounding conductor shall be an insulated copper conductor with a continuous outer finish that is either green or green with one or more yellow stripes.

**(c) Size of Equipment Grounding Conductor.** The insulated equipment grounding conductor shall be sized in accordance with Section 250-95 but not smaller than No. 12.

**(d) Branch-Circuit Equipment Grounding Conductor.** The insulated equipment grounding conductor for branch circuits shall terminate at a grounding terminal in a remote panelboard or the grounding terminal in the main service equipment.

**(e) Feeder Equipment Grounding Conductors.** Where a feeder supplies a remote panelboard, an insulated equipment grounding conductor shall extend from a grounding terminal in the service equipment to a grounding terminal in the remote panelboard.



**555-8. Wiring Over and Under Navigable Water.** Wiring over and under navigable water shall be subject to approval by the authority having jurisdiction.

**555-9. Gasoline Dispensing Stations — Hazardous (Classified) Locations.**

**(a) Class I, Division 1 Location.** The following spaces shall be considered a Class I, Division 1 location:

(1) The space within the dispenser from its base to a level measured 4 feet (1.22 m) vertically from its base.

(2) The space outside the dispenser for a distance measured 4 feet (1.22 m) horizontally from all points of the dispenser and measured vertically upwards for a distance of 18 inches (457 mm) from the base of the dispenser.

(3) The entire space between the base of the dispenser and the lowest water surface for a distance of 4 feet (1.22 m) measured horizontally from any point on the outside of the dispenser.

**(b) Class I, Division 2 Location.** In an outside location, the following space shall be considered a Class I, Division 2 location (spaces which are Class I, Division 1 as defined above are excluded. Buildings within the following space which are not suitably cut off shall be included.) This space shall include the entire volume enveloped within the following limits:

(1) A horizontal limit of 20 feet (6.1 m) from all points on the exterior enclosure of a dispenser.

(2) An upper limit of 18 inches (457 mm) measured vertically from the base of the dispenser.

(3) A lower limit which shall be the lowest water surface.

(FPN): For further information, see *Marinas and Boatyards*, NFPA 303-1984 (ANSI).

**555-11. Sealing.**

**(a) At Dispenser.** An approved seal shall be provided in each conduit run entering or leaving a dispenser or any cavities or enclosures in direct communication therewith.

**(b) At Boundary.** Additional seals shall be provided in accordance with Section 501-5. Section 501-5(a)(4) and (b)(2) shall apply to horizontal as well as to vertical boundaries of the defined hazardous (classified) locations.

## Chapter 6. Special Equipment

### ARTICLE 600 — ELECTRIC SIGNS AND OUTLINE LIGHTING

#### A. General

**600-1. Scope.** This article covers the installation of conductors and equipment for electric signs and outline lighting as defined in Article 100.

**600-2. Disconnect Required.** Each outline lighting installation, and each sign of other than the portable type, shall be controlled by an externally operable switch or breaker which will open all ungrounded conductors.

(a) **In Sight of Sign.** The disconnecting means shall be within sight of the sign or outline lighting which it controls.

*Exception: Signs operated by electronic or electromechanical controllers located external to the sign shall have a disconnecting means located within sight from the controller location. The disconnecting means shall disconnect the sign and the controller from all ungrounded supply conductors and shall be so designed that no pole can be operated independently. The disconnecting means shall be permitted to be in the same enclosure with the controller. The disconnecting means shall be capable of being locked in the open position.*

(b) **Control Switch Rating.** Switches, flashers, and similar devices controlling transformers shall be either rated for controlling inductive load(s) or have an ampere rating not less than twice the ampere rating of the transformer.

*Exception: For other than motors, ac general-use snap switches shall be permitted to be used on alternating-current circuits to control inductive loads not exceeding the ampere rating of the switch.*

(FPN): See Section 380-14 for rating of snap switches.

**600-3. Enclosures as Pull Boxes.** The wiring method used to supply signs and outline lighting shall terminate in the sign or transformer enclosures.

*Exception: Such signs and transformer boxes shall be permitted to be used as pull or junction boxes for conductors supplying other adjacent signs, outline lighting systems and floodlights that are part of signs provided the conductors extending from the equipment are protected by an overcurrent device rated 20 amperes or less.*

**600-4. Listing Required.** Every electric sign of any type, fixed or portable, shall be listed and installed in conformance with that listing, unless otherwise permitted by special permission.

**600-5. Grounding.** Signs, troughs, tube terminal boxes, and other metal frames shall be grounded in the manner specified in Article 250.

*Exception No. 1: Insulated and Inaccessible.* Where they are insulated from ground and from other conducting surfaces and are inaccessible to unauthorized persons.

*Exception No. 2: Isolated Parts.* Isolated noncurrent-carrying metal parts of outline lighting may be bonded by No. 14 conductors, protected from physical damage, and grounded in accordance with Article 250.

#### 600-6. Branch Circuits.

(a) **Rating.** Circuits which supply lamps, ballasts, and transformers, or combinations, shall be rated not to exceed 20 amperes. Circuits containing electric-discharge lighting transformers exclusively shall not be rated in excess of 30 amperes.

(b) **Required Branch Circuit.** Each commercial building and each commercial occupancy with ground floor footage accessible to pedestrians shall be provided at an accessible location outside the occupancy, with at least one outlet for sign or outline lighting use. The outlet(s) shall be supplied by a 20-ampere branch circuit which supplies no other load.

*Exception: Interior hallways or corridors shall not be considered outside the occupancy.*

(c) **Computed Load.** The load for the required branch circuit installed for the supply of exterior signs or outline lighting shall be computed at a minimum of 1200 volt-amperes.

#### 600-7. Marking.

(a) **Signs.** Signs shall be marked with the maker's name; and, for incandescent lamp signs, with the number of lampholders; and, for electric-discharge-lamp signs, with input amperes at full load and input voltage. The marking of the sign shall be visible after installation.

(b) **Transformers.** Transformers shall be marked with the maker's name; and transformers for electric-discharge-lamp signs shall be marked with the input rating in amperes or volt-amperes, the input voltage, and the open-circuit output voltage.

#### 600-8. Enclosures.

(a) **Conductors and Terminals.** Conductors and terminals in sign boxes, cabinets, and outline troughs shall be enclosed in metal or other noncombustible material.

*Exception: The supply leads shall not be required to be enclosed.*

(b) **Cutouts, Flashers, etc.** Cutouts, flashers, and similar devices shall be enclosed in metal boxes, the doors of which shall be arranged so they can be opened without removing obstructions or finished parts of the enclosure.

(c) **Strength.** Enclosures shall have ample strength and rigidity.

(d) **Material.** Signs and outline lighting shall be constructed of metal or other noncombustible material. Wood shall be permitted for external decoration if placed not less than 2 inches (50.8 mm) from the nearest lampholder or current-carrying part.

*Exception: Portable signs of the indoor type shall not be required to meet this requirement.*

(e) **Minimum Thickness — Enclosure Metal.** Sheet copper shall be at least 20 ounce [0.028 inch (711 micrometers)]. Sheet steel shall be of No. 28 MSG.

*Exception: For outline lighting and for electric-discharge signs, sheet steel shall be of No. 24 MSG if not ribbed, corrugated, or embossed over its entire surface and of No. 26 MSG if it is so ribbed, corrugated, or embossed.*

(f) **Protection of Metal.** All steel parts of enclosures shall be galvanized or otherwise protected from corrosion.

(g) **Enclosures Exposed to Weather.** Enclosures for outdoor use shall be weatherproof and shall have at least two drain holes, each not larger than  $\frac{1}{2}$  inch (12.7 mm) or smaller than  $\frac{1}{4}$  inch (6.35 mm).

**600-9. Portable Signs.** Portable signs, letters, fixtures, symbols, and similar displays used in conjunction with fixed outdoor signs shall only be used when in compliance with all applicable provisions of this Code and, in addition, shall meet all of the following requirements:

(a) **Weatherproof Receptacle and Attachment Plug.** A weatherproof receptacle and attachment plug having one pole for grounding shall be provided for each individual letter, fixture, or sign.

(b) **Cords.** All cords shall be Type S, SJ, SJO, SJT, SJTO, SO, or ST, 3-conductor, with one conductor grounded as provided in the foregoing.

(c) **Cord from Ground Level.** No cord shall be less than 10 feet (3.05 m) from the ground level directly underneath.

#### **600-10. Clearances.**

(a) **Vertical and Horizontal.** Signs and outline system enclosures shall have not less than the vertical and horizontal clearances from open conductors specified in Article 225.

(b) **Elevation.** The bottom of sign and outline lighting enclosures shall not be less than 16 feet (4.88 m) above areas accessible to vehicles.

*Exception: The bottom of such enclosures shall be permitted to be less than 16 feet (4.88 m) above areas accessible to vehicles where such enclosures are protected from physical damage.*

**600-11. Outdoor Portable Signs.** The internal wiring of an outdoor sign that is portable or mobile and is readily accessible shall be supplied from, and protected by, ground-fault circuit-interrupters identified for use with portable electric signs, thereby providing protection for personnel. The required ground-fault circuit-interrupter shall be permitted on or within the sign or as an integral part of the attachment plug of the supply cord connected to the sign. Conductive supports of a sign covered by this section shall be considered part of the sign.

### **B. 600 Volts, Nominal, or Less**

#### **600-21. Installation of Conductors.**

(a) **Wiring Method.** Conductors shall be installed in rigid metal conduit, intermediate metal conduit, rigid nonmetallic conduit, flexible metal conduit, liquidtight flexible metal conduit, liquidtight flexible nonmetallic conduit, electrical metallic tubing, metal-clad cable, Type AC cable, metal troughing, mineral-insulated-metal-sheathed cable, and metal poles complying with all requirements of Section 410-15(b).

(b) **Insulation and Size.** Conductors shall be of a type listed for general use and shall not be smaller than No. 14.

*Exception No. 1: Conductors not smaller than No. 18 of a type listed in Table 402-3 shall be permitted:*

- a. In portable signs.*
- b. As short leads permanently attached to lampholders or electric-discharge ballasts.*
- c. As leads not more than 8 feet (2.44 m) long permanently attached to electric-discharge lampholders or electric-discharge ballasts if the leads are enclosed in wiring channels.*
- d. For signs with multiple incandescent lamps requiring one conductor from a control to one or more lamps whose total load does not exceed 250 watts, if in an approved cable assembly of two or more conductors.*

*Exception No. 2: Conductors not smaller than No. 20 shall be permitted as short leads permanently attached to synchronous motors.*

**(c) Exposed to Weather.** Conductors in raceways, metal-clad cable, or enclosures exposed to the weather shall be of the lead-covered type or other type specially listed for the conditions.

*Exception: This shall not apply when rigid metal conduit, intermediate metal conduit, rigid nonmetallic conduit, electrical metallic tubing, or enclosures are made raintight and arranged to drain.*

**(d) Number of Conductors in Raceway.** The number of conductors in a raceway for sign fixtures shall be in accordance with Table 1 of Chapter 9.

**(e) Conductors Soldered to Terminals.** Where the conductors are fastened to lampholders other than of the pin type, they shall be soldered to the terminals or made with wire connectors, and the exposed parts of conductors and terminals shall be treated to prevent corrosion. Where the conductors are fastened to pin-type lampholders that protect the terminals from the entrance of water, and that have been found acceptable for sign use, the conductors shall be of the stranded type but shall not be required to be soldered to the terminals.

**600-22. Lampholders.** Lampholders shall be of the unswitched type having bodies of suitable insulating material and shall be so constructed and installed as to prevent turning. Miniature lampholders shall not be employed for outdoor signs and outline lighting. The screw-shell contact of all sign lampholders in grounded circuits shall be connected to the grounded conductor of the circuit.

**600-23. Conductors Within Signs and Troughs.** Wires within the sign and outline lighting troughs shall be installed as to be mechanically secure.

**600-24. Protection of Leads.** Bushings shall be employed to protect wires feeding through enclosures.

### C. Over 600 Volts, Nominal

**600-31. Installation of Conductors.**

**(a) Wiring Method.** Conductors shall be installed as concealed conductors on insulators, in rigid metal conduit, in intermediate metal conduit, in rigid nonmetallic conduit, in flexible metal conduit, in liquidtight flexible metal conduit, or in electrical metallic tubing, or as Type MC cable.

**(b) Insulation and Size.** Conductors shall be of a type identified for voltage not less than the voltage of the circuit and shall not be smaller than No. 14.

*Exception: Conductors not smaller than No. 18 shall be permitted:*

*a. As leads not more than 8 feet (2.44 m) long permanently attached to electric-discharge lampholders or electric-discharge ballasts if the leads are enclosed in wiring channels.*

*b. In show window displays or small portable signs, as leads not more than 8 feet (2.44 m) long that run from the line ends of the tubing to the secondary windings of transformers if the leads are permanently attached within the transformer enclosure.*

**(c) Bends in Conductors.** Sharp bends in the conductors shall be avoided.

**(d) Concealed Conductors on Insulators — Indoors.** Concealed conductors on insulators shall be separated from each other and from all objects other than the insulators on which they are mounted by a spacing of not less than 1½ inches (38 mm) for voltages above 10,000 and not less than 1 inch (25.4 mm) for voltages of 10,000 or less. They shall be installed in channels lined with noncombustible material and used for no other purpose, except that the primary circuit conductors shall be permitted to be in the same channel. The insulators shall be of noncombustible, nonabsorbent material. Concealed conductors on insulators shall not be allowed outside the sign enclosure.

**(e) Conductors in Raceways.** Where the conductors are covered with lead or other metal sheathing, the covering shall extend beyond the end of the raceway, and the surface of the cable shall not be injured where the covering terminates.

(1) In damp or wet locations, the insulation on all conductors shall extend beyond the metal covering or raceway not less than 4 inches (102 mm) for voltages over 10,000, 3 inches (76 mm) for voltages over 5000 but not exceeding 10,000, and 2 inches (50.8 mm) for voltages of 5000 or less.

(2) In dry locations the insulation shall extend beyond the end of the metal covering or raceways not less than 2½ inches (64 mm) for voltages over 10,000, 2 inches (50.8 mm) for voltages over 5000 but not exceeding 10,000, and 1½ inches (38 mm) for voltages of 5000 or less.

(3) For conductors at grounded midpoint terminals, no spacing shall be required.

(4) A metal raceway containing a single conductor from one secondary terminal of a transformer shall not exceed 20 feet (6.1 m) in length.

**(f) Show Windows and Similar Locations.** Conductors that hang freely in the air, away from combustible material, and where not subject to physical damage, as in some show window displays, shall not be required to be otherwise protected.

**(g) Between Tubing and Grounded Midpoint.** Conductors shall be permitted to be run from the ends of tubing to the grounded midpoint of transformers specifically designed for the purpose and provided with terminals at the midpoint. Where such connections are made to the transformer grounded midpoint, the connections between the high-voltage terminals of the transformer and the line ends of the tubing shall be as short as possible.

**600-32. Transformers.**

(a) **Voltage.** The transformer secondary open-circuit voltage shall not exceed 15,000 volts with an allowance on test of 1000 volts additional. For end-grounded transformers, the secondary open-circuit voltage shall not exceed 7500 volts with an allowance on test of 500 volts additional.

(b) **Type.** Transformers shall be of a type identified for use with electrical-discharge tubing and shall be limited in rating to a maximum of 4500 volt-amperes.

Open core-and-coil-type transformers shall be limited to 5000 volts with an allowance on test of 500 volts and to indoor applications in small portable signs.

Transformers for outline lighting installations shall have secondary current ratings not more than 30 milliamperes.

*Exception: Where the transformers and all wiring connected to them are installed in accordance with Article 410 for electric-discharge lighting of the same voltage.*

(c) **Exposed to Weather.** Transformers used outdoors shall be of the weatherproof type or shall be protected from the weather by enclosure in the sign body or in a separate metal box.

(d) **Exposed Secondary Connections.** The high-voltage windings of transformers shall not be connected in parallel or in series.

*Exception No. 1: Two transformers each having one end of its high-voltage winding connected to the metal enclosure shall be permitted to have their high-voltage windings connected in series to form the equivalent of a midpoint-grounded transformer. The grounded ends shall be connected by insulated conductors not smaller than No. 14.*

*Exception No. 2: Transformers for small portable signs, show windows, and similar locations that are equipped with leads permanently attached to the secondary winding within the transformer enclosure and that do not extend more than 8 feet (2.44 m) beyond the enclosure for attaching to the line ends of the tubing shall not be smaller than No. 18.*

(e) **Accessibility.** Transformers shall be located where accessible and shall be securely fastened in place.

(f) **Working Space.** A work space at least 3 feet (914 mm) high and measuring at least 3 feet (914 mm) by 3 feet (914 mm) horizontally shall be provided about each transformer or its enclosure where not installed in a sign.

(g) **Attic Locations.** Transformers shall be permitted to be located in attics provided there is a passageway at least 3 feet (914 mm) in height and at least 2 feet (610 mm) in width, provided with a suitable permanent fixed walkway or catwalk at least 12 inches (305 mm) in width extending from the point of entry into the attic to each transformer.

**600-33. Electric-Discharge Tubing.**

(a) **Design.** The tubing shall be of such length and design as not to cause a continuous overvoltage on the transformer.

(b) **Support.** Tubing shall be adequately supported on noncombustible, nonabsorbent supports. Tubing supports shall, where practicable, be adjustable.

(c) **Contact with Flammable Material and Other Surfaces.** The tubing shall be free from contact with flammable material and shall be located where not normally exposed to physical damage. Where operating at over 7500 volts, the tubing shall be supported on noncombustible, nonabsorbent insulating supports that maintain a spacing of not less than  $\frac{1}{4}$  inch (6.35 mm) between the tubing and the nearest surface.

#### 600-34. Terminals and Electrode Receptacles for Electric-Discharge Tubing.

(a) **Terminals.** Terminals of the tubing shall be inaccessible to unqualified persons and isolated from combustible material and grounded metal or shall be enclosed. Where enclosed, they shall be separated from grounded metal and combustible material by noncombustible, nonabsorbent insulating material or by not less than  $1\frac{1}{2}$  inches (38 mm) of air. Terminals shall be relieved from stress by the independent support of the tubing.

(b) **Tube Connections Other than with Receptacles.** Where tubes do not terminate in receptacles designed for the purpose, all live parts of tube terminals and conductors shall be supported so as to maintain a separation of not less than  $1\frac{1}{2}$  inches (38 mm) between conductors or between conductors and any grounded metal.

(c) **Receptacles.** Electrode receptacles for the tubing shall be of noncombustible, nonabsorbent insulating material.

(d) **Bushings.** Where electrodes enter the enclosure of outdoor signs or of an indoor sign operating at a voltage in excess of 7500 volts, bushings shall be used unless receptacles are provided. Electrode terminal assemblies shall be supported not more than 6 inches (152 mm) from the electrode terminals.

(e) **Show Windows.** In the exposed type of show-window signs, terminals shall be enclosed by receptacles.

(f) **Receptacles and Bushing Seals.** A flexible, nonconducting seal shall be permitted to close the opening between the tubing and the receptacle or bushing against the entrance of dust or moisture. This seal shall not be in contact with grounded conductive material and shall not be depended upon for the insulation of the tubing.

(g) **Enclosures of Metal.** Enclosures of metal for electrodes shall not be less than No. 24 MSG sheet metal.

(h) **Enclosures of Insulating Material.** Enclosures of insulating material shall be noncombustible, nonabsorbent, and suitable for the voltage of the circuit.

(i) **Live Parts.** Live parts shall be enclosed or suitably guarded to prevent contact.

600-35. **Switches on Doors.** Doors or covers giving access to uninsulated parts of indoor signs or outline lighting exceeding 600 volts, nominal, and accessible to unqualified persons shall either be provided with interlock switches that on the opening of the doors or covers disconnect the primary circuit, or shall be so fastened that the use of other than ordinary tools will be necessary to open them.

#### 600-36. Fixed Outline Lighting and Skeleton-type Signs for Interior Use.

(a) **Tube Support.** Gas tubing shall be supported independently of the conductors by means of insulators of noncombustible, nonabsorbent mate-



rials such as glass or porcelain or by suspension from suitable wires or chains.

(b) **Transformers.** Transformers shall be installed in metal enclosures and as near as practicable to the gas tubing system.

(c) **Supply Conductors.** The supply conductors for the transformers shall be enclosed in grounded metal raceway or rigid nonmetallic conduit where installed in accordance with the requirements of Article 347.

(d) **High-Tension Conductors.** High-tension conductors shall be insulated for the voltage of the circuit and shall be enclosed in grounded metal raceway.

*Exception: Conductors not exceeding 4 feet (1.22 m) in length between gas tubing and adjacent metal enclosures shall be permitted to be enclosed in continuous glass or other insulating sleeves.*

**600-37. Portable Gas Tube Signs for Show Windows and Interior Use.** This section shall apply to the installation and use of portable gas tube signs.

(a) **Location.** Portable gas tube signs shall be for indoor use only.

(b) **Transformer.** The transformer shall be of the window type or shall be within a metal enclosure.

(c) **Supply Conductors.** Supply conductors shall consist of hard or extra-hard usage-type cord containing an equipment grounding conductor. The cord shall not exceed 10 feet (3.05 m) in length.

(d) **High-Voltage Conductors.** High-voltage conductors shall not be more than 6 feet (1.83 m) long and shall be located where not subject to mechanical injury, and shall be insulated for the voltage of the circuit and be protected by continuous glass or other insulating sleeves or tubing.

(e) **Grounding.** Transformers and attached noncurrent-carrying metal parts shall be grounded in accordance with Article 250.

(f) **Support.** Portable indoor signs shall be held in place by not more than two open hooks attached to the transformer case.

## ARTICLE 604 — MANUFACTURED WIRING SYSTEMS

**604-1. Scope.** The provisions of this article apply to field-installed wiring using off-site manufactured subassemblies for branch circuits, remote-control circuits, signaling circuits, and communication circuits in accessible areas.

### 604-2. Definition.

**Manufactured Wiring System:** A system containing component parts that are assembled in the process of manufacture and cannot be inspected at the building site without damage or destruction to the assembly.

**604-3. Uses Permitted.** The manufactured wiring systems shall be permitted in accessible and dry locations and in plenums and spaces used for environmental air, when listed for this application, and installed in accordance with Section 300-22.

*Exception: In concealed spaces, one end of tapped cable shall be permitted to extend into hollow walls for direct termination at switch and outlet points.*

**604-4. Uses Not Permitted.** Where conductors or cables are limited by the provisions in Articles 333 and 334.

**604-5. Other Articles.** Installations shall conform with, but not be limited only to, applicable sections of the following articles: 110, 200, 210, 220, 250, 300, 310, 333, 334, 350, 410, 545, 640, 700, 725 and 800.

**604-6. Construction.**

(a) **Cable or Conduit Types.**

(1) Cable shall be listed armored cable or metal-clad cable containing nominal 600-volt No. 12 AWG copper insulated conductors with a bare No. 12 AWG copper equipment grounding conductor.

(2) Conduit shall be listed flexible metal conduit containing nominal 600-volt No. 12 AWG copper insulated conductors with an insulated or bare No. 12 AWG copper equipment grounding conductor.

(3) Each section shall be marked to identify the type of cable or conduit.

(b) **Receptacles and Connectors.** Receptacles and connectors shall be locking type, uniquely polarized and identified for the purpose and shall be part of a listed assembly for the appropriate system.

(c) **Other Component Parts.** Other component parts shall be listed for the appropriate system.

**604-7. Unused Outlets.** All unused outlets shall be capped to effectively close the connector openings.

## ARTICLE 605 — OFFICE FURNISHINGS

(Consisting of Lighting Accessories and Wired Partitions)

**605-1. Scope.** This article covers electrical equipment, lighting accessories and wiring systems used to connect, or contained within, or installed on relocatable wired partitions.

**605-2. General.** Wiring systems shall be identified as suitable for providing power for lighting accessories and appliances in wired partitions. These partitions shall not extend from floor to ceiling.

(a) **Use.** These assemblies shall be installed and used only as provided for by this article.

(b) **Other Articles.** Except as modified by the requirements of this article, all other articles of this Code shall apply.

(c) **Hazardous (Classified) Locations.** Where used in hazardous (classified) locations, these assemblies shall conform with Articles 500 through 517 in addition to this article.

**605-3. Wireways.** All conductors and connections shall be contained within wiring channels of metal or other material identified as suitable for the conditions of use. Wiring channels shall be free of projections or other conditions that may damage conductor insulation.

(FPN): Conductors as used in this section do not include flexible cord.

**605-4. Partition Interconnections.** The electrical connection between partitions shall be a flexible assembly identified for use with wired partitions.

*Exception: Flexible cord shall be permitted for the connection between partitions provided all of the following conditions are met:*

- a. *The cord is extra-hard usage type.*
- b. *The partitions are mechanically contiguous.*
- c. *The cord is not longer than necessary for maximum positioning of the partitions but in no case to exceed 2 feet (610 mm).*
- d. *The cord is terminated at an attachment plug and cord-connector with strain relief.*

**605-5. Lighting Accessories.** Lighting equipment listed and identified for use with wired partitions shall comply with all of the following:

(a) **Support.** A means for secure attachment or support shall be provided.

(b) **Connection.** Where cord- and plug-connection is provided, the cord length shall be suitable for the intended application, but shall not exceed 9 feet (2.74 m) in length. The cord shall not be smaller than 18 AWG; shall contain an equipment grounding conductor, and shall be of the hard usage type. Connection by other means shall be identified as suitable for the condition of use.

(c) **Receptacle Outlet.** Convenience receptacles shall not be permitted in lighting accessories.

**605-6. Fixed-type Partitions.** Wired partitions that are fixed (secured to building surfaces) shall be permanently connected to the building electrical system by one of the wiring methods of Chapter 3.

**605-7. Free-Standing Type Partitions.** Partitions of the free-standing type (not fixed) shall be permitted to be permanently connected to the building electrical system by one of the wiring methods of Chapter 3.

**605-8. Free-Standing Type Partitions, Cord- and Plug-Connected.** Individual partitions of the free-standing type, or groups of individual partitions which are electrically connected, mechanically contiguous and do not exceed 30 feet (9.14 m) when assembled shall be permitted to be connected to the building electrical system by a single flexible cord and plug provided all of the following conditions are met:

(a) **Flexible Power Supply Cord.** The flexible power-supply cord shall be extra-hard usage type with No. 12 AWG or larger conductors with an insulated grounding conductor and not exceeding 2 feet (610 mm) in length.

(b) **Receptacle Supplying Power.** The receptacle(s) supplying power shall be on a separate circuit serving only panels and no other loads and shall be located not more than 12 inches (305 mm) from the partition which is connected to it.

(c) **Receptacle Outlets, Maximum.** Individual partitions or groups of interconnected individual partitions shall not contain more than thirteen 15-ampere, 125-volt receptacle outlets.

**(d) Multiwire Circuits, Not Permitted.** Individual partitions or groups of interconnected individual partitions shall not contain multiwire circuits.

(FPN): See Section 210-4 for circuits supplying partitions in Sections 605-6 and 605-7.

## ARTICLE 610 — CRANES AND HOISTS

### A. General

**610-1. Scope.** This article covers the installation of electric equipment and wiring used in connection with cranes, monorail hoists, hoists, and all runways.

(FPN): For further information, see Safety Code for Cranes, Derricks, Hoists, Jacks, and Slings (ANSI B-30).

**610-2. Special Requirements for Particular Locations.**

**(a) Hazardous (Classified) Locations.** All equipment which operates in a hazardous (classified) location shall conform to Article 500.

(1) Equipment used in locations which are hazardous because of the presence of flammable gases or vapors shall conform to Article 501.

(2) Equipment used in locations which are hazardous because of combustible dust shall conform to Article 502.

(3) Equipment used in locations which are hazardous because of the presence of easily ignitable fibers or flyings shall conform to Article 503.

**(b) Combustible Materials.** Where a crane, hoist, or monorail hoist operates over readily combustible material, the resistors shall be placed in a well-ventilated cabinet composed of noncombustible material so constructed that it will not emit flames or molten metal.

*Exception: Resistors shall be permitted to be located in a cage or cab constructed of noncombustible material which encloses the sides of the cage or cab from the floor to a point at least 6 inches (152 mm) above the top of the resistors.*

**(c) Electrolytic Cell Lines.** See Section 668-32.

### B. Wiring

**610-11. Wiring Method.** Conductors shall be enclosed in raceways or be Type MC cable, or Type MI cable.

*Exception No. 1: Contact conductors.*

*Exception No. 2: Short lengths of open conductors at resistors, collectors, and other equipment.*

*Exception No. 3: Where flexible connections are necessary to motors and similar equipment, flexible stranded conductors shall be installed in flexible metal conduit, liquidtight flexible metal conduit, multiconductor cable, or an approved nonmetallic enclosure.*

*Exception No. 4: Where multiconductor cable is used with a suspended pushbutton station, the station shall be supported in some satisfactory manner that protects the electric conductors against strain.*

**610-12. Raceway Terminal Fittings.** Conductors leaving raceways shall comply with one of the following:

(a) **Separately Bushed Hole.** A box or terminal fitting having a separately bushed hole for each conductor shall be used wherever a change is made from rigid metal conduit, intermediate metal conduit, electrical metallic tubing, metal-clad cable, mineral-insulated cable, or surface raceway wiring to open wiring. A fitting used for this purpose shall not contain taps or splices and shall not be used at fixture outlets.

(b) **Bushing in Lieu of a Box.** A bushing shall be permitted to be used in lieu of a box at the end of a rigid metal conduit, intermediate metal conduit or electrical metallic tubing where the raceway terminates at unenclosed controls or similar equipment including contact conductors, collectors, resistors, brakes, power circuit limit switches, and dc split frame motors.

**610-13. Types of Conductors.** Conductors shall comply with Table 310-13.

*Exception No. 1: Conductor(s) exposed to external heat or connected to resistors shall have a flame-resistant outer covering or be covered with flame-resistant tape individually or as a group.*

*Exception No. 2: Contact conductors along runways, crane bridges, and monorails shall be permitted to be bare, and shall be copper, aluminum, steel, or other alloys or combinations thereof in the form of hard drawn wire, tees, angles, tee rails, or other stiff shapes.*

*Exception No. 3: Flexible conductors shall be permitted to be used to convey current and, where practicable, cable reels or take-up devices shall be employed.*

**610-14. Rating and Size of Conductors.**

(a) **Ampacity.** The allowable ampacities of conductors shall be as shown in Table 610-14(a).

(FPN): For the ampacities of conductors between controllers and resistors, see Section 430-23.

(b) **Secondary Resistor Conductors.** Where the secondary resistor is separate from the controller, the minimum size of the conductors between controller and resistor shall be calculated by multiplying the motor secondary current by the appropriate factor from Table 610-14(b) and selecting a wire from Table 610-14(a).

(c) **Minimum Size.** Conductors external to motors and controls shall not be smaller than No. 16.

*Exception No. 1: No. 18 wire in multiple conductor cord shall be permitted for control circuits at not over 7 amperes.*

*Exception No. 2: Wires not smaller than No. 20 shall be permitted for electronic circuits.*

**Table 610-14(a). Ampacities of Insulated Conductors up to Four Conductors in Raceway or Cable\*\*  
Used with Short-Time Rated Crane and Hoist Motors**

Max. Operating Temp.	75°C		90°C		110°C	
	Type MTW, RH, RHW, THW, THWN, XHHW		Type AVB, FEP, FEPB, PFA, PFAH, RHH, SA, TA, THHN, XHHW*, Z		Type AVA	
	60 min	30 min	60 min	30 min	60 min	30 min
16	10	12				
14	25	26	31	32	38	40
12	30	33	36	40	45	50
10	40	43	49	52	60	65
8	55	60	63	69	73	80
6	76	86	83	94	93	105
5	85	95	95	106	109	121
4	100	117	111	130	126	147
3	120	141	131	153	145	168
2	137	160	148	173	163	190
1	143	175	158	192	177	215
0	190	233	211	259	239	294
00	222	267	245	294	275	331
000	280	341	305	372	339	413
0000	300	369	319	399	352	440
250	364	420	400	461	447	516
300	455	582	497	636	554	707
350	486	646	542	716	616	809
400	538	688	593	760	666	856
450	600	765	660	836	740	930
500	660	847	726	914	815	1004

Other insulations shown in Table 310-13 and approved for the temperatures and location shall be permitted to be substituted for those shown in Table 610-14(a). The allowable ampacities of conductors used with 15-minute motors shall be the 30-minute ratings increased by 12 percent. \* For dry locations only. See Table 310-13. \*\* For 5 or more simultaneously energized power conductors in raceway or cable, the ampacity of each power conductor shall be reduced to a value of 80 percent of that shown in the table.

**Table 610-14(b). Secondary Conductor Rating Factors**

Time in Seconds		Ampacity of Wire in Percent of Full-Load Secondary Current
On	Off	
5	75	35
10	70	45
15	75	55
15	45	65
15	30	75
15	15	85
Continuous Duty		110

**(d) Contact Conductors.** Contact wires shall have an ampacity not less than that required by Table 610-14(a) for 75°C wire, and in no case shall they be smaller than the following:

Distance Between End Strain Insulators or Clamp-type Intermediate Supports	Size of Wire
0-30 feet	No. 6
30-60 feet	No. 4
Over 60 feet	No. 2

For SI units: one foot = 0.3048 meter.

**(e) Calculation of Motor Load.**

(1) For one motor, use 100 percent of motor nameplate full-load ampere rating.

(2) For multiple motors on a single crane or hoist, the minimum circuit ampacity of the power supply conductors shall be the nameplate full-load ampere rating of the largest motor or group of motors for any single crane-motion, plus 50 percent of the nameplate full-load ampere rating of the next largest motor or group of motors, using that column of Table 610-14(a) which applies to the longest time-rated motor.

(3) For multiple cranes and/or hoists supplied by a common conductor system, compute the motor minimum ampacity for each crane as defined in Section 610-14(e), add them together, and multiply the sum by the appropriate demand factor from Table 610-14(e).

**(f) Other Loads.** Additional loads, such as heating, lighting, and air conditioning, shall be provided for by application of the appropriate sections of this Code.

**(g) Nameplate.** Each crane, monorail, or hoist shall be provided with a visible nameplate marked with the maker's name, the rating in volts, frequency, number of phases, and circuit amperes as calculated in Section 610-14(e) and (f).